

Fixação na Parede
Montaje en la Pared
Wall Assembly

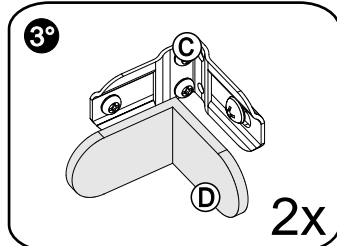

União dos Módulos
Unión de los módulos
Pieces Junction

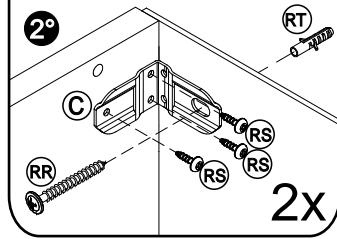
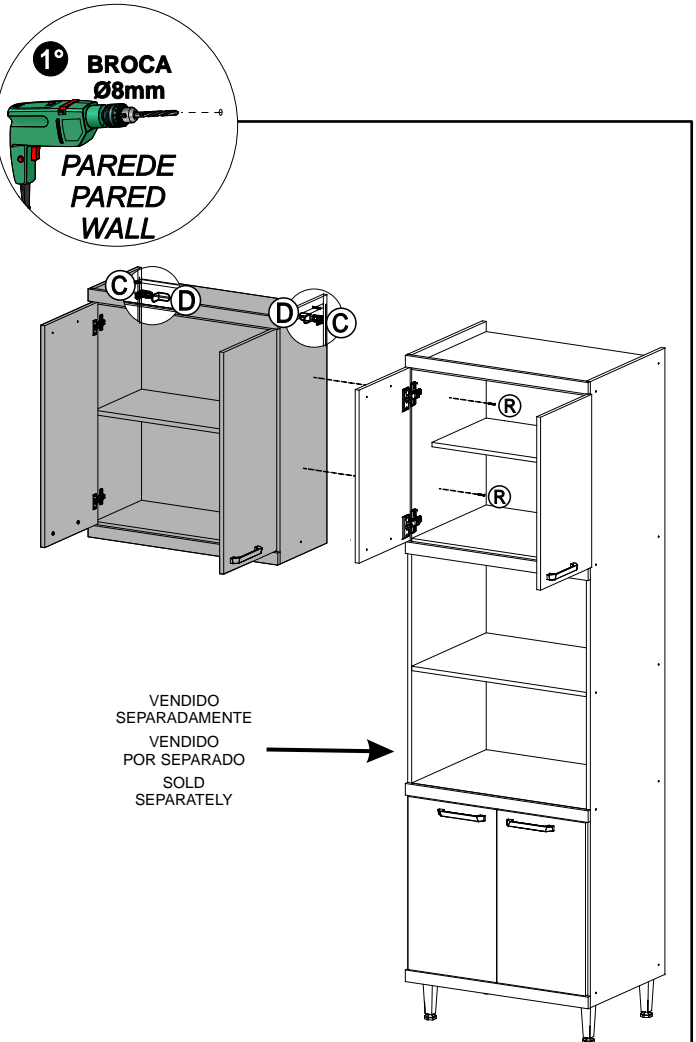
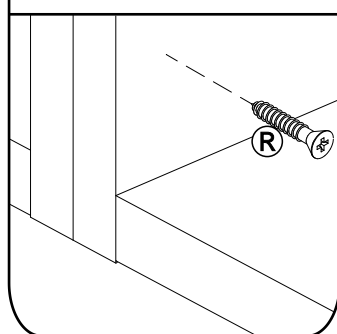

OBRIGATÓRIO FIXAR NA PAREDE
OBLIGATORIO DE FIJAR EN LA PARED
MANDATORY TO FIX ON THE WALL

INSTRUÇÕES DE MONTAGEM
INSTRUCCIONES DE ARMADO
ASSEMBLY INSTRUCTIONS

REF.5126

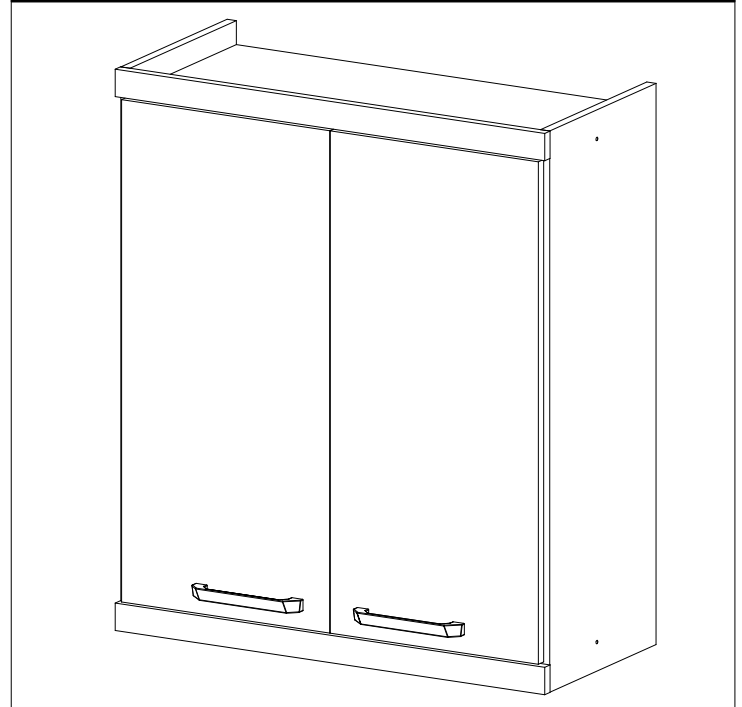

OBRIGATÓRIO FIXAR NA PAREDE
OBLIGATORIO DE FIJAR EN LA PARED
MANDATORY TO FIX ON THE WALL

REF.:5126/5134/5139/5141/5148/5151/5152/5163/5800/
5801/5801MM/5802/5803/5806/5807/5814/5815/5818/5819/
5832/5833/5834/5835/5849/5850/5851/5852/MP5800

FERRAMENTAS NECESSÁRIAS
HERRAMIENTAS NECESARIAS
TOOLS NECESSARY

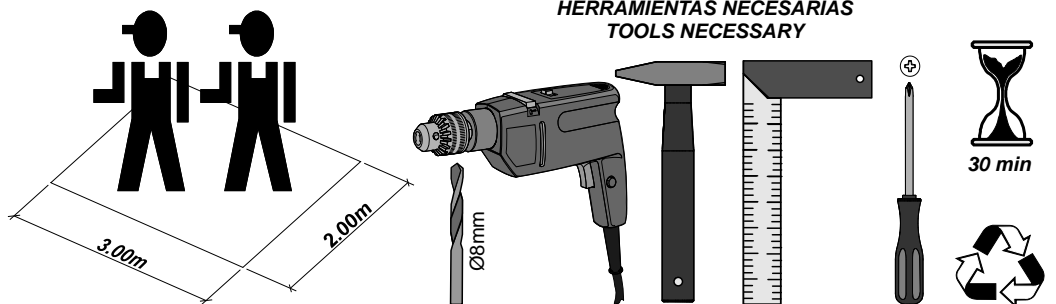

LISTA DE FERRAGENS / LISTA DE MATERIALES / HARDWARE LIST



A		Tampa Adesiva	08
B		Parafuso 4,5 x 50	04
C		Suporte Aéreo	02
D		Capa p/ Suporte Aéreo	02
E		Parafuso 3,5 x 14	16
H		Cavilha 6,0 x 30	12
R		Parafuso 4,0 x 25	04
Y		Prego 10 x 10	25
AA		Dobradiça	04
AE		Fixador de Costas	06
AT		Cantoneira Plástica	06
BW		Parafuso 3,5 x 25	04
BX		Bisnaga de Cola 5g	01
CC		Parafuso 3,5 X 12	12
RR		Parafuso 5,0 x 45	02
RS		Parafuso 3,5 x 14	06
RT		Bucha Ø8mm	02
XX		Puxador 160mm	02

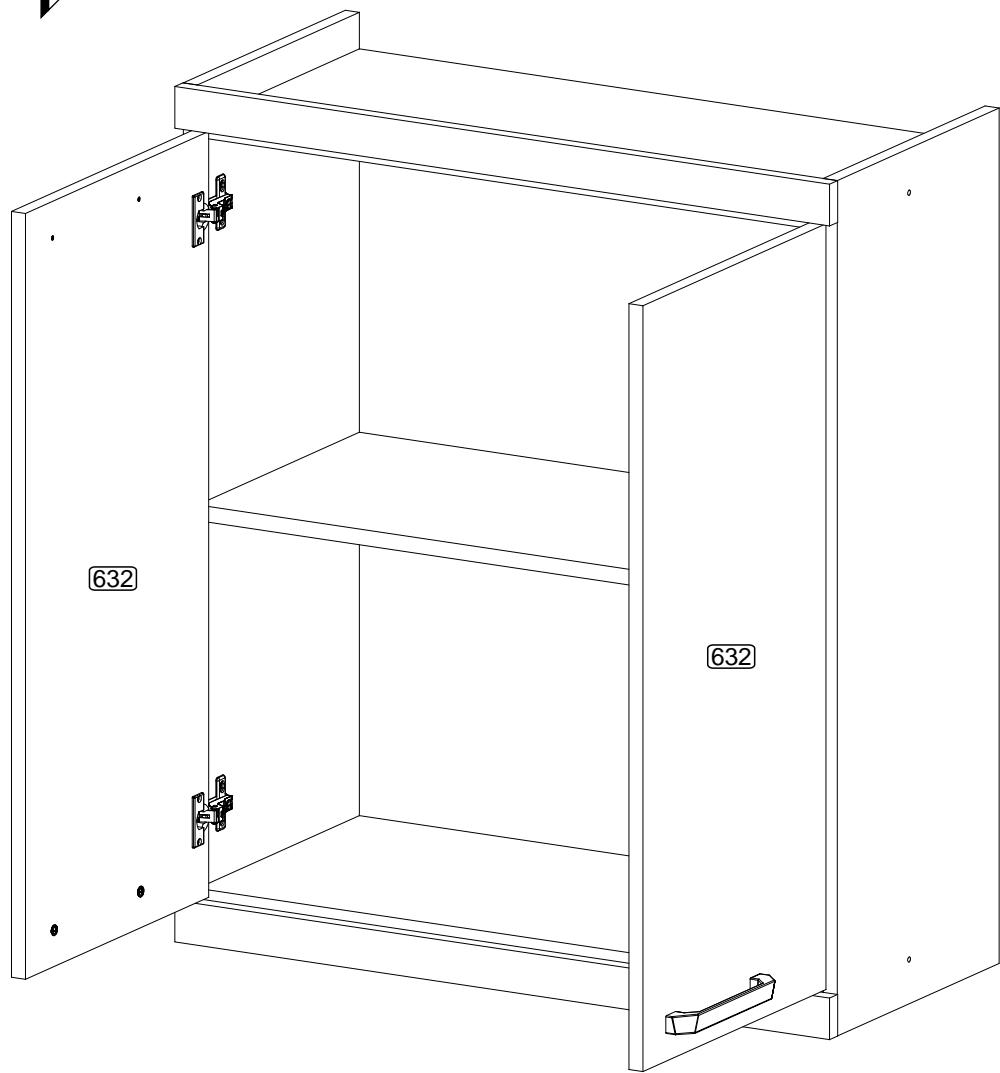

Ref.:5126 - 12/Maior/2020 - Rev. 05

Utilizar a régua abaixo para medir as ferragens:

Utilizar la regla abajo para medir los herrajes: Use the ruler below to measure the hardware:

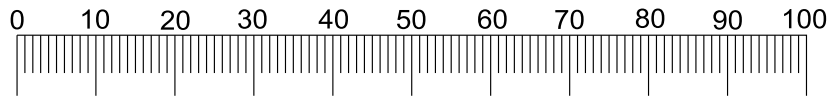

Medidas em mm / Medidas en mm / Measurements in mm

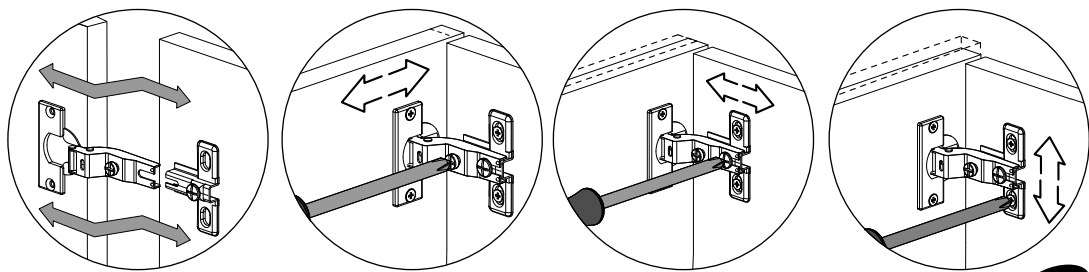

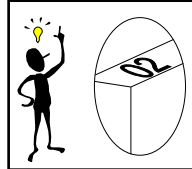
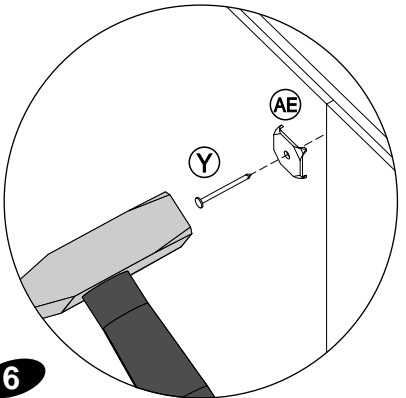
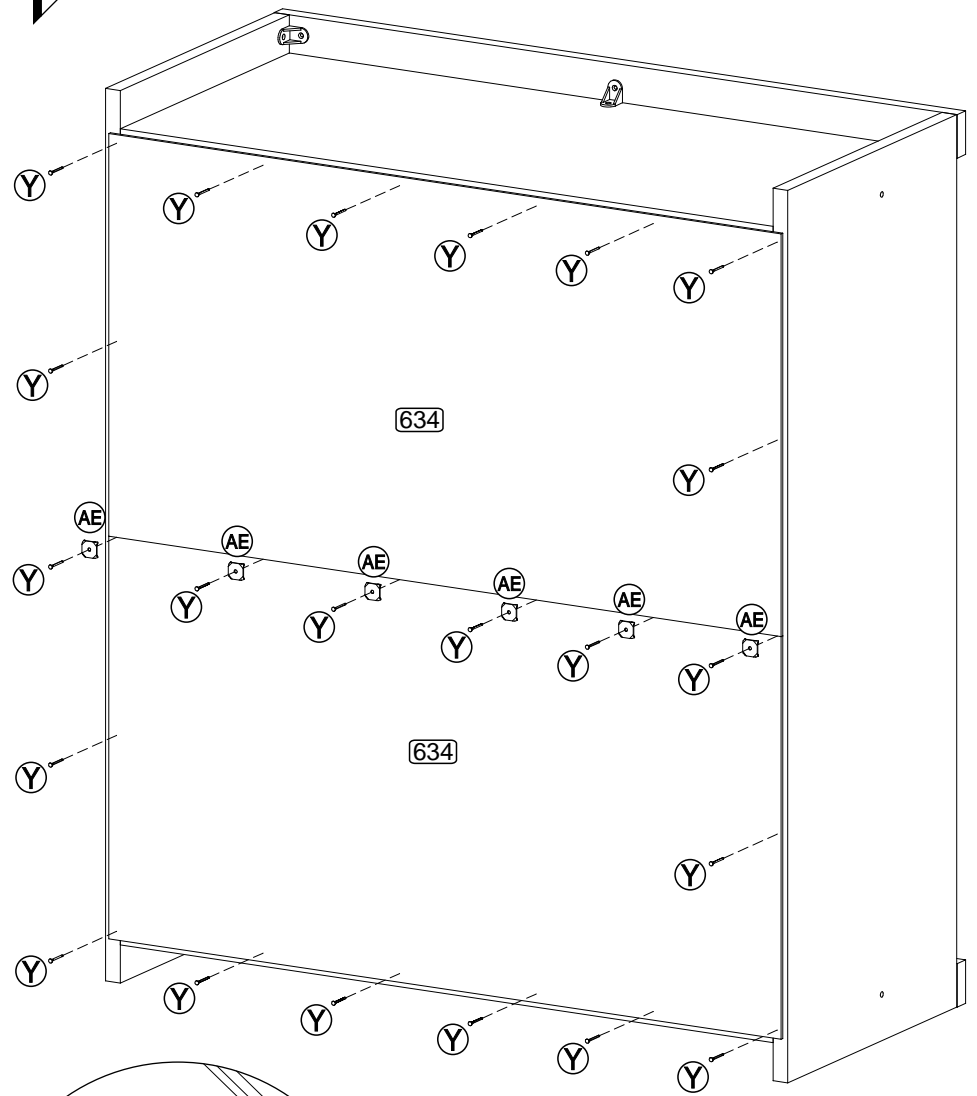

Senhor montador!
Informamos que a numeração das peças encontra-se no topo das mesmas conforme desenho acima.

Señor Armador!
Les informamos que la numeración de las piezas encuentranse arriba de las mismas, de acuerdo al modelo arriba.

Dear Assembler!
We inform you that the number of each piece is located on the top of it, according to the model shown above.

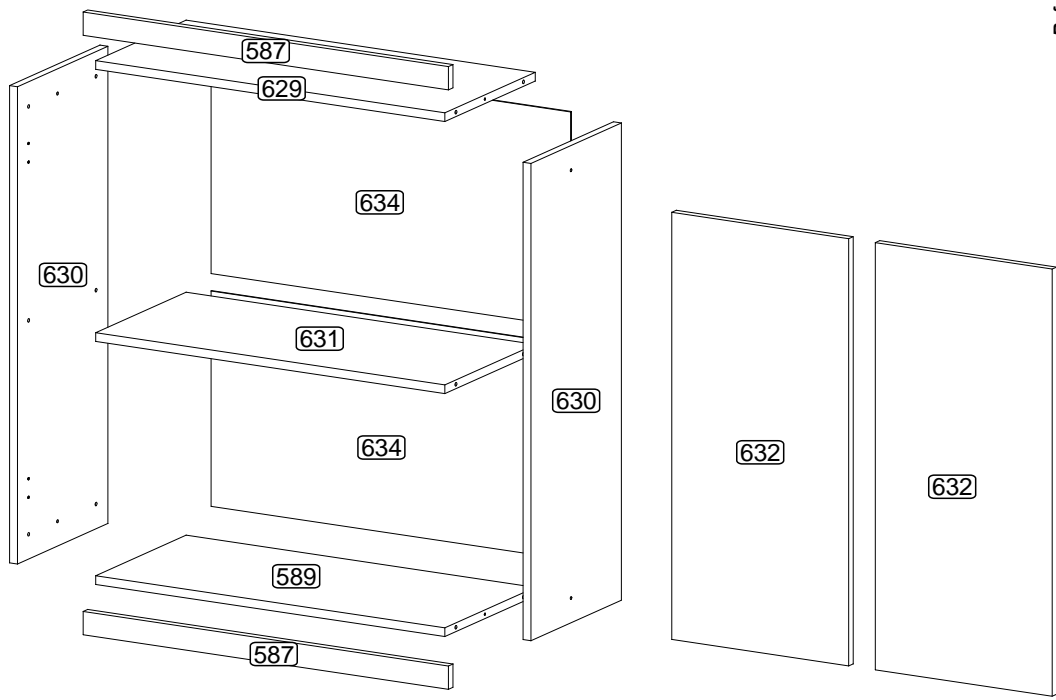

POR	LISTA DE PEÇAS	ESP	LISTA DE PIEZAS	ENG	PART LIST
N°	DENOMINAÇÃO	N°	DENOMINACIÓN	N°	DESCRIPTION
587	MOLDURA	587	MOLDURA	587	FRAME
589	BASE	589	BASE	589	BASE
329	TAMPO	329	TAPA	329	TOP
630	LATERAL	630	LATERAL	630	SIDE
631	PRATELEIRA CAVILHA	631	ESTANTE TARUGO	631	BOLT SHELF
632	PORTA	632	PUERTA	632	DOOR
634	COSTA	634	RESPALDO	634	BACK

PRÉ-MONTAGEM / PRÉ-ARMADO / PRÉ-ASSEMBLAGE

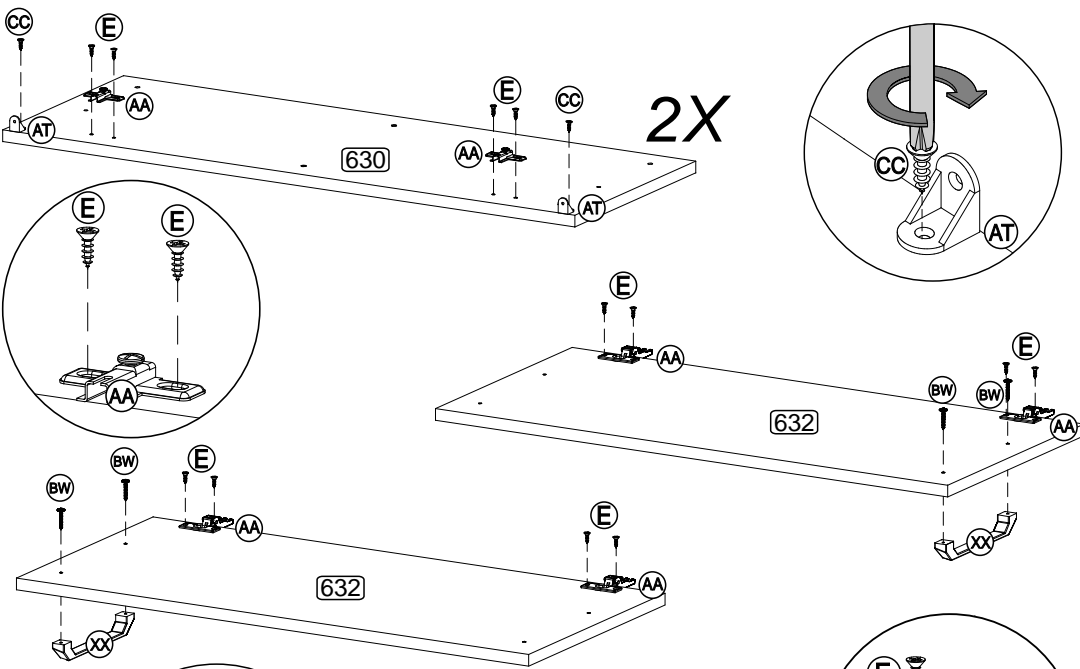

Fixar o parafuso no puxador com uma chave de fenda cruzada.
Fijar el tornillo en el tirador con un destornillador cruzado.
Secure the screw on the handle with a crossed screwdriver.

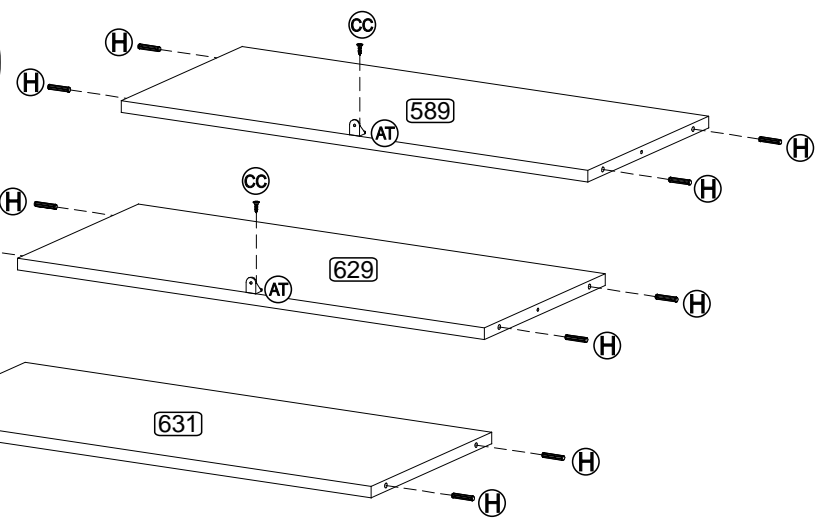
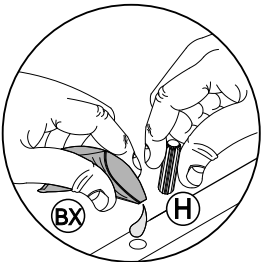
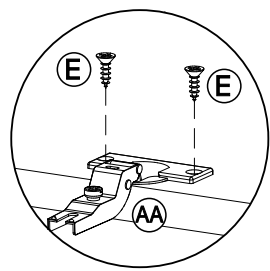
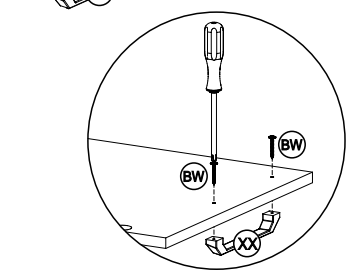

Passo
Paso
Step
01

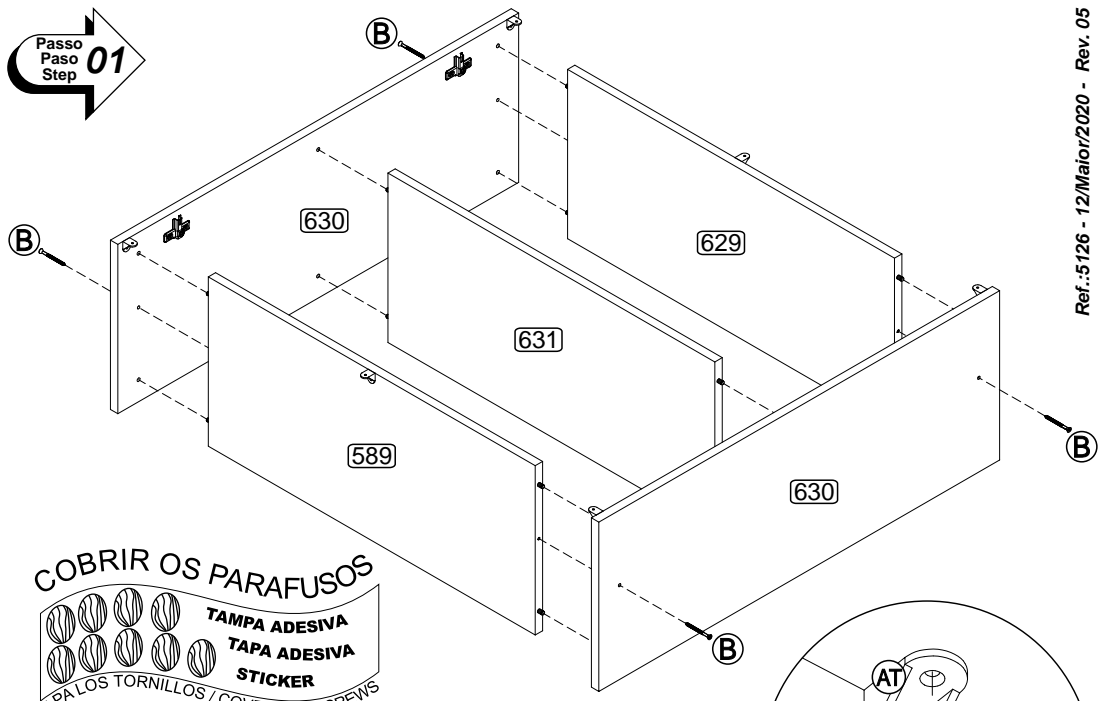

COBRIR OS PARAFUSOS
TAPA ADESIVA
TAPA ADESIVA
STICKER
TAPA LOS TORNILLOS / COVER THE SCREWS

Passo
Paso
Step
02

