

RP4340- ROUPEIRO

Manual de Montagem
Assembly Instructions
Instrucción de Montaje

decibal[®]
móveis

Produto Montado
Producto final
Assembled

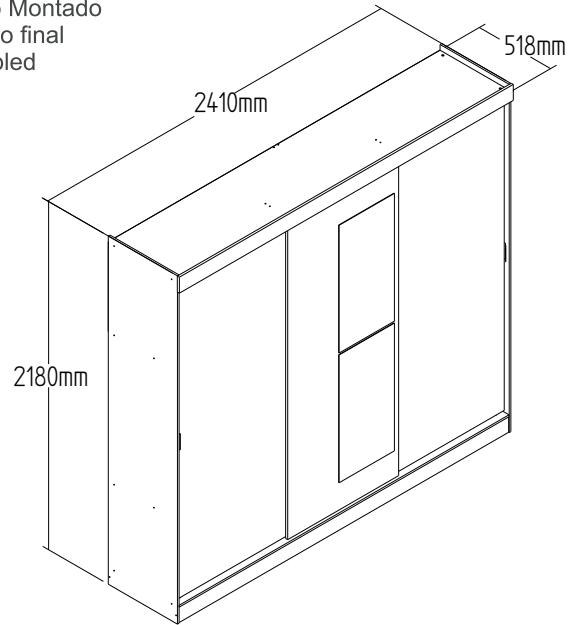

1°

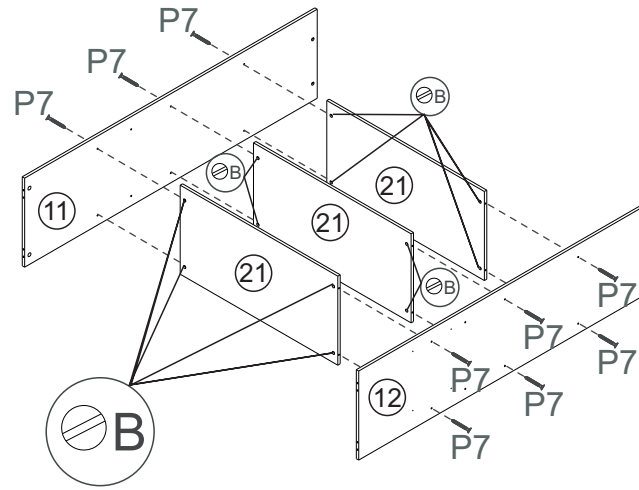

2°

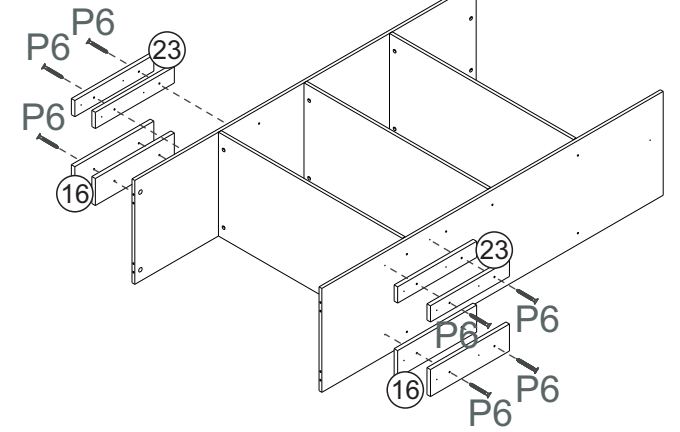

3°

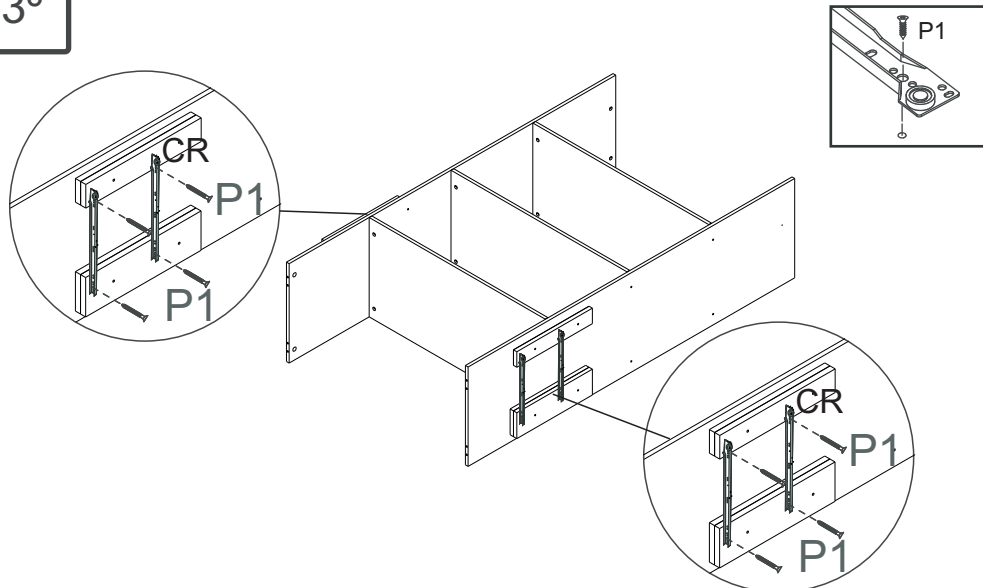

4°

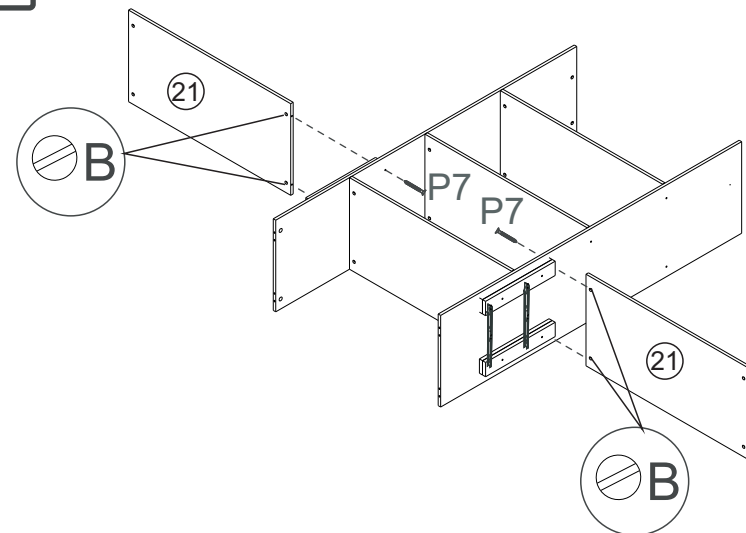

RP4340- ROUPEIRO

Manual de Montagem
Assembly Instructions
Instrucción de Montaje

decibal[®]
móveis

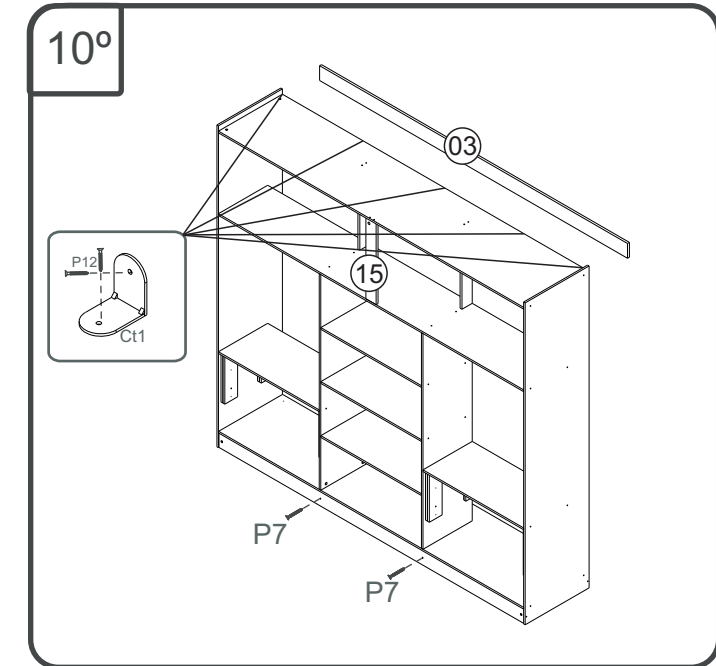
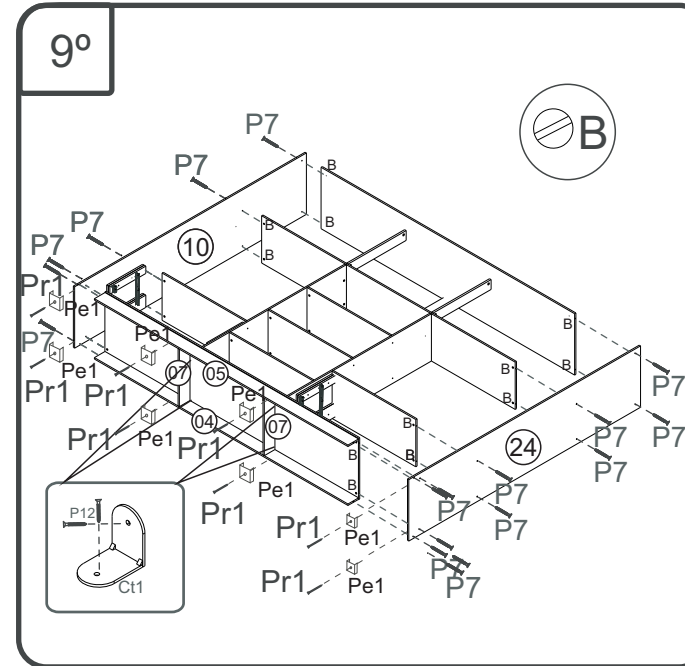
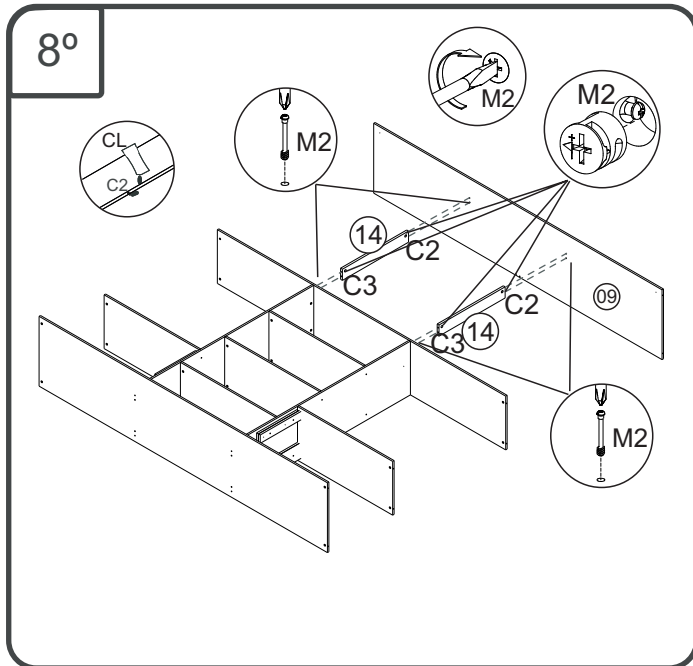
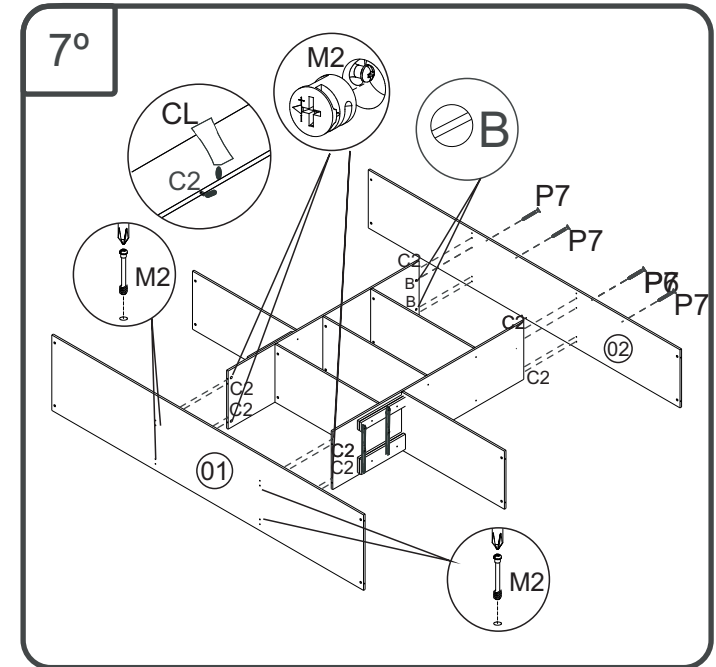
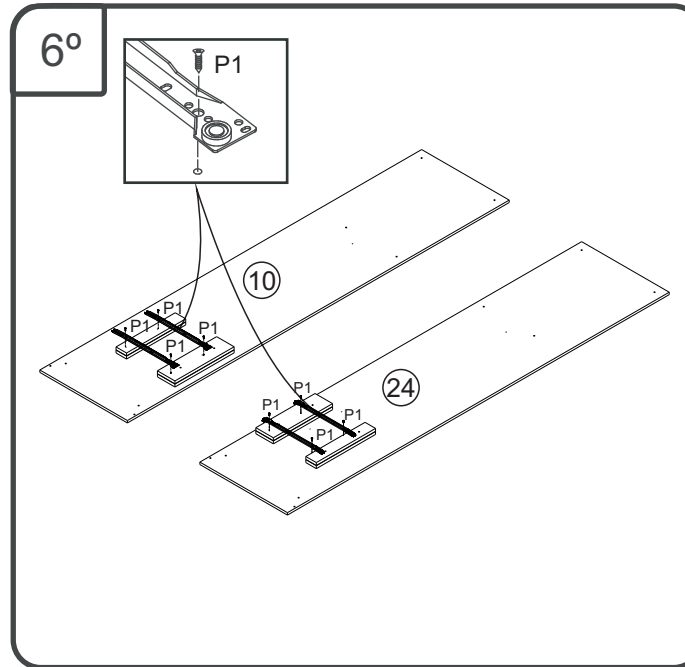
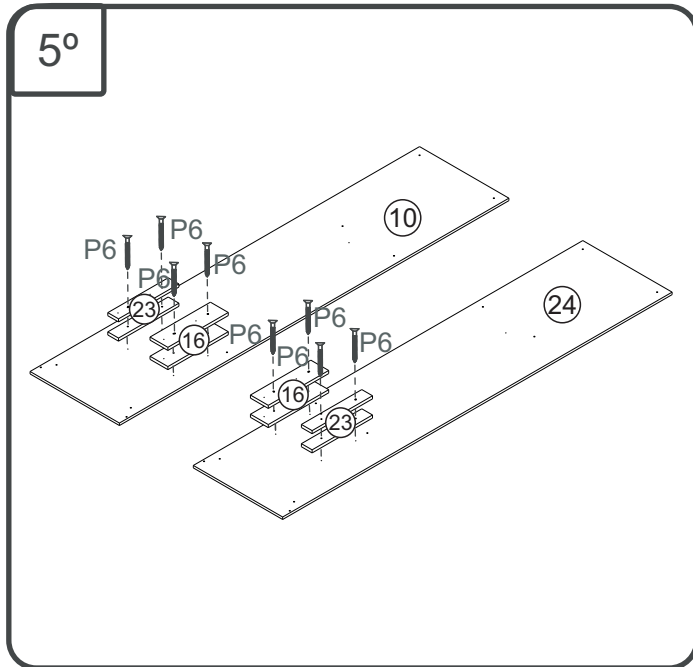

11°

Utilizar parafuso P12 para fixar costa (20) na pilastra (15).

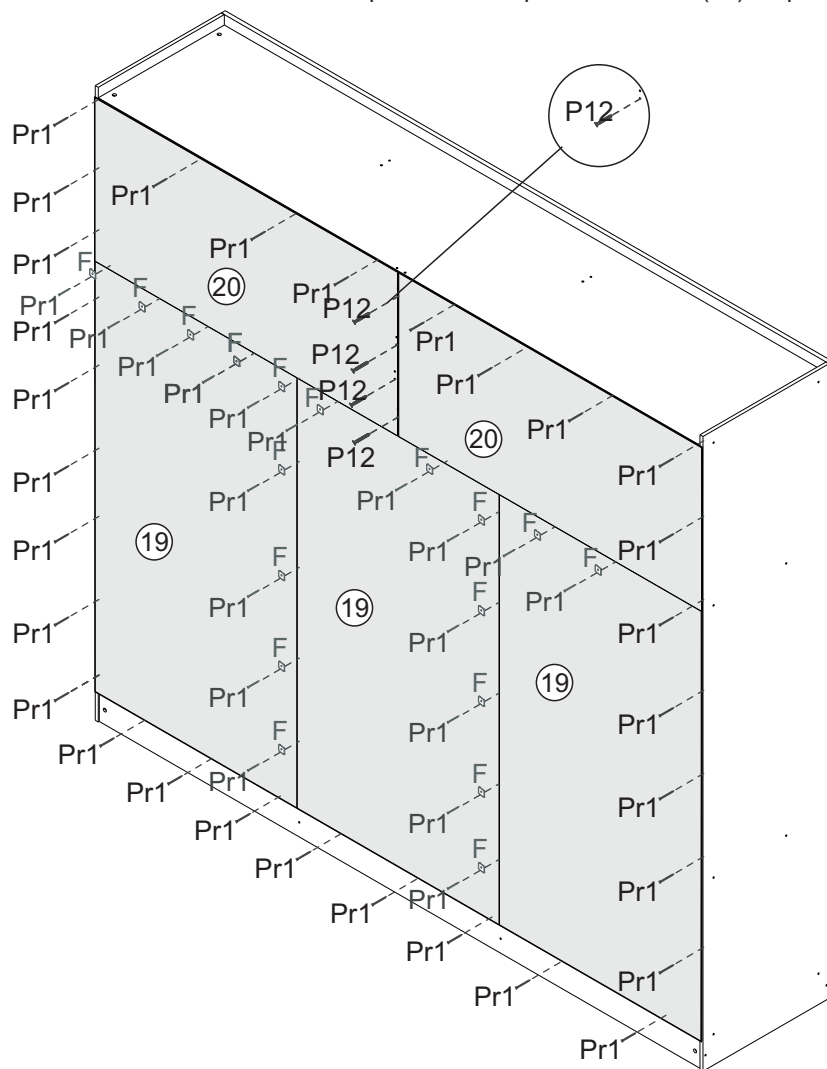

12°

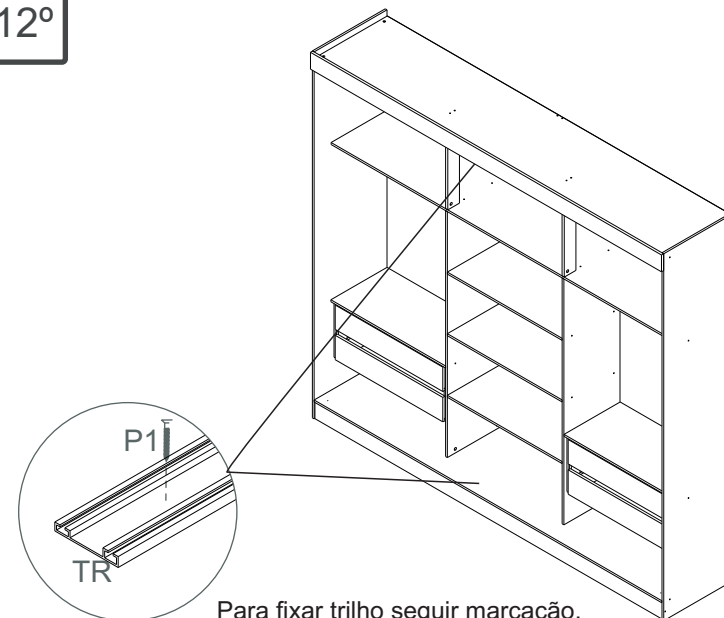

Para fixar trilho seguir marcação.

13°

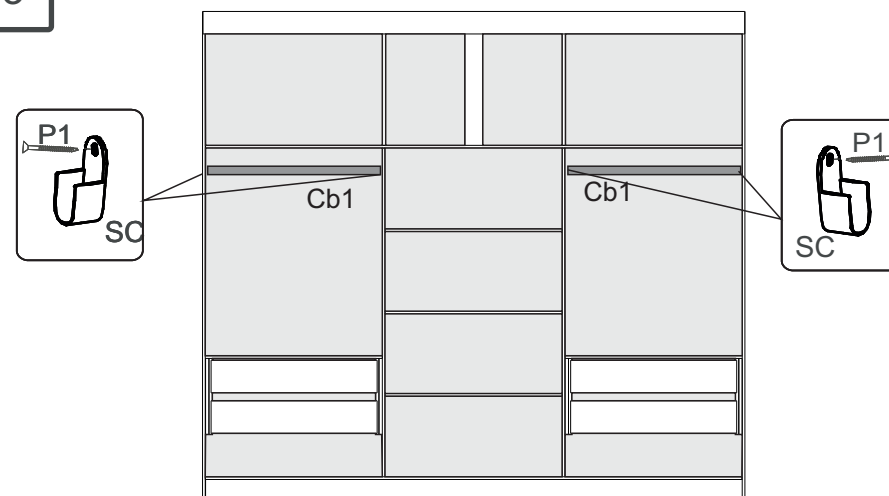

14°

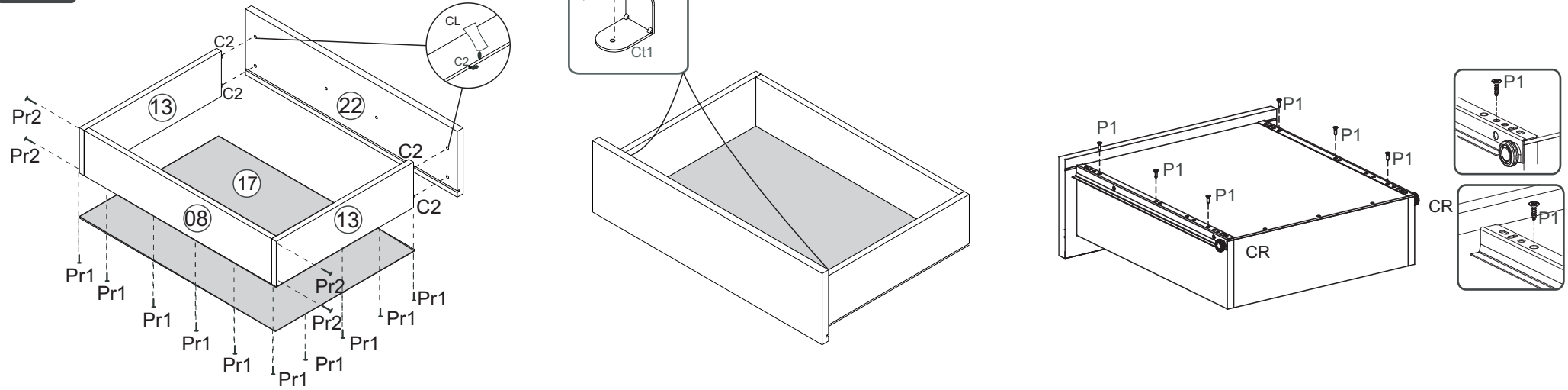

15°

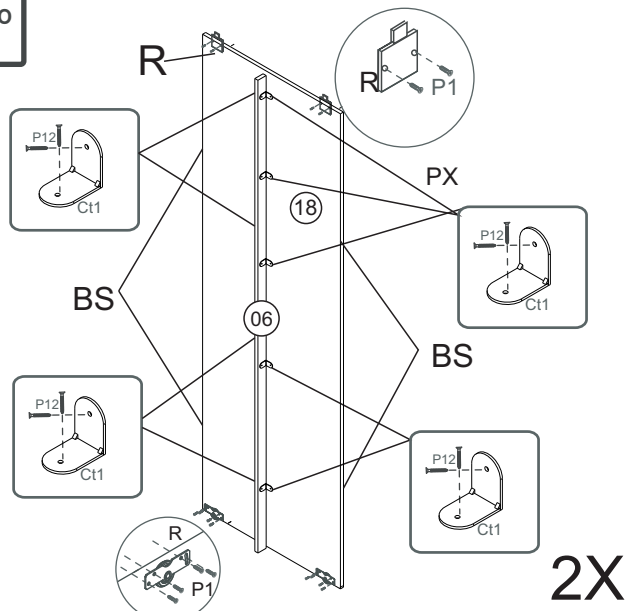

2X

16°

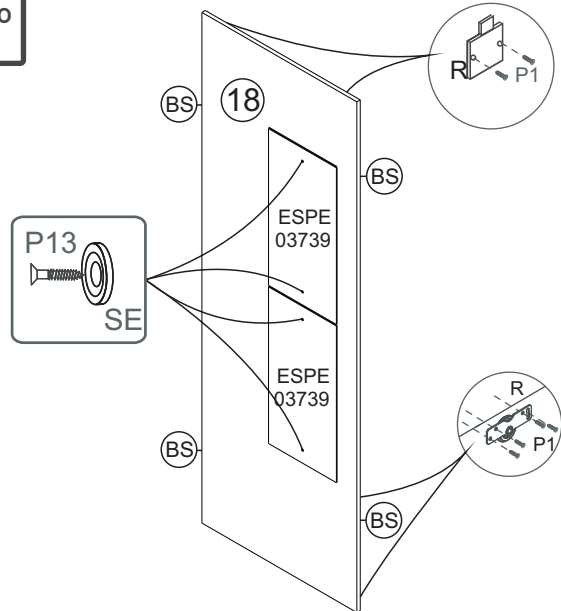

Porta do trilho dianteiro.

RP4340- ROUPEIRO

Manual de Montagem
Assembly Instructions
Instrucción de Montaje

decibal[®]
móveis

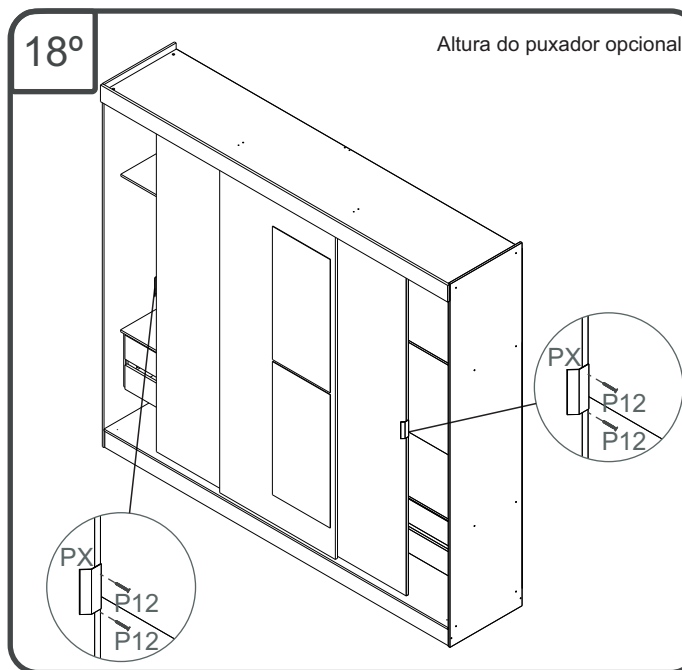
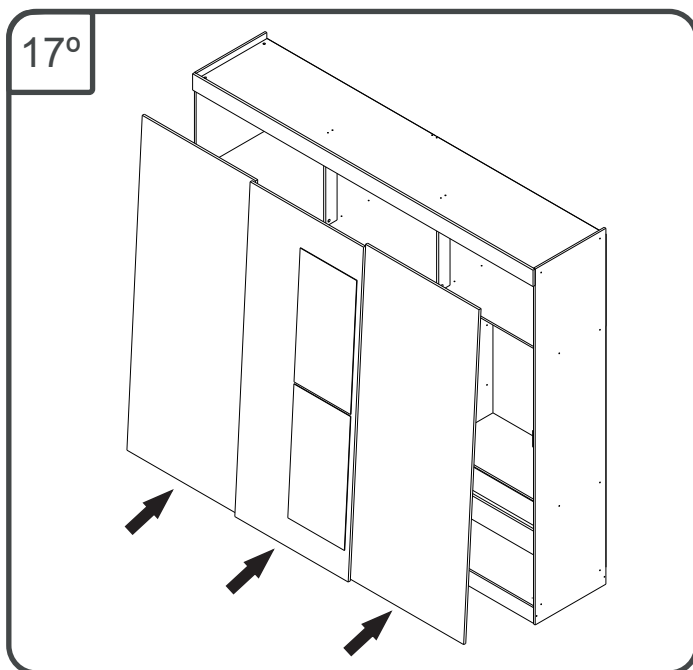

Ferramenta necessárias
Necessary tools
Herramientas necesarias



240 min.



2 montador
2 ajustador
2 fitter

www.decibal.com.br

ATENÇÃO!!!! montadores e consumidores

* Para limpar o móveis utilize somente um pano úmido (umedecido em água pura ou água com sabão neutro). Depois, passe um pano seco. Evite a umidade excessiva.

* Evite usar álcool, água sanitária, detergente e outros produtos químicos, mesmo diluídos em água. Não utilize produtos abrasivos de nenhuma espécie

ATENCIÓN!!!! montadores e consumidores

* Para limpiar el mueble utilice solamente un paño húmedo (humedecido con agua limpia o con un jabón suave). A continuación, utilice un paño seco. Evite el exceso de humedad.

* Evite uso de alcohol, hipoclorídido solución basada, detergente y otros productos químicos, mismo diluídos en agua. No utilice productos abrasivos de ningún tipo.

ATTENTION!!!! assemblers and consumers

* To clean the furniture, use only a damp cloth (humidify it only in pure water ou water and neutral soap). After, use a dry cloth. Avoid excessive humidity.

* Avoid using alcohol, bleach, detergent and other chemical products, even diluted in water. Do not use any kind of abrasive cleaning agents to clean the furniture.

The use of such products may jeopardize the final characteristics of the furniture.

Instrucción de Montaje

Relação de Peças/ Relación de Piezas/Parts List

Nº	CÓDIGO/ CODE	DESCRIÇÃO/ DESCRIPCIÓN/ DESCRIPTION	QTD/ CANT	VOL.
1	0534902	BASE INF 2385X500X12MM P	1,00	1
2	0534916	BASE 2385X385X12MM P	1,00	1
3	0534922	RODAFORRO 2408X100X15MM P	1,00	1
4	0534918	RODAPÉ/ZÓCALO/BASEBOARD 2385X100X12MM P	1,00	1
5	0536088	RODAPÉ/ZÓCALO/BASEBOARD 2385X100X12MM P	1,00	1
6	0534939	TRAVESSA/TRAVIESA/TRVERSE 1900X40X12MM P	2,00	1
7	0534919	RODAPÉ/ZÓCALO/BASEBOARD 468X100X12MM P	2,00	1
8	0534910	BATENTE/REVÉS CAJÓN/ DRAWER BACK 688X90X12MM P	4,00	1
9	0534907	BASE 2385X500X12MM P	1,00	1
10	0534903	LATERAL /LATERAL/SIDE 2180X500X12MM P	1,00	2
11	0534905	DIVISORIA ESQ/DIVIDER 1461X385X12MM P	1,00	2
12	0534906	DIVISORIA DIR/DIVIDER 1461X385X12MM P	1,00	2
13	0531283	LATERAL GAVETA/LATERAL CAJÓN/ DRAWER SIDE 350X90X12MM P	8,00	2
14	0534920	PILAstra/PILASTER 547X80X15MM P	2,00	2
15	0536089	PILAstra/PILASTER 547X80X15MM P	1,00	2
16	0536091	PILAstra/PILASTER 338X100X15MM P	8,00	2
17	0534912	FUNDO GAVETA/FONDO CAJÓN/ DRAWER BOTTOM 350X90X12MM P	4,00	2
18	0534913	PORTA/PUERTA/DOOR 2000X802X15MM P	3,00	3
19	0534915	COSTA/REVÉS/BACK 1478X802X2,8MM P	3,00	3
20	0534914	COSTA/REVÉS/BACK 1201X562X2,8MM P	2,00	3
21	0534917	PRATELEIRA/ESTANTE/SHELF 787X385X12MM P	5,00	4
22	0534909	FRENTE GAVETA/FRENTE CAJÓN/ DRAWER FRONT 734X145X15MM P	4,00	4
23	0536090	PILAstra/PILASTER 338X60X15MM P	8,00	4
24	0534904	LATERAL /LATERAL/SIDE 2180X500X12MM P	1,00	2



ATENÇÃO!!!! montadores e consumidores

* Ajustar o torque da parafusadeira para não danificar as peças escareando o parafuso *









ATENCIÓN!!!! montadores e consumidores

* Ajuste el torque del destornillador para no dañar las piezas avallanando el tornillo *

ATTENTION!!!! assemblers and consumers

* Adjust the torque of the screwdriver so as not to damage the parts by countersinking the screw *

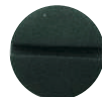
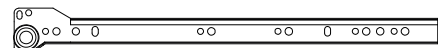
escala (N/A)





LEGENDA	DESCRIÇÃO/ DESCRIPCIÓN/ DESCRIPTION	CÓDIGO	QUANT.
CL	 COLA/PEGAMENTO/GLUE	01213	01
ET	 ETIQUETA LOGO DECIBAL/LABEL DECIBAL	01312	01
Ct1	 CANTONEIRA/PIEZA L/SHEET	03077	62
BS	 SILICONE/TAPON SILICONA/STOPPER	02921	10
R	 ROLDANA CIV CORR C2 (1 PT)	07387	03
FX	 FIXADOR COSTA/FIJADOR FONDO/FIXER COAST	01331	40
Pe1	 PÉ/PATA/FOOT	01367	08
B	 BUCHA/BUJE/BUCHING	02734	40
CR	 CORREDICA/CORREDERA/METALIC SLIDE LARG	01225	04
TR	 TRILHO/TRILLO/RAIL	11399	02

RP4340- ROUPEIRO





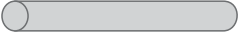
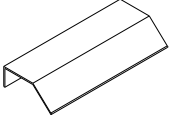





Manual de Montagem
Assembly Instructions
Instrucción de Montaje



escala (N/A)

LEGENDA	DESCRIÇÃO/DESCRIPCIÓN/DESCRIPTION	CÓDIGO	QUANT.
SE	 SUPORTE ESP/ APOYOSUPPORT	01371	04
SC	 SUPORTE CABIDEIRO SOPORTE PERCHERO/SUPPORT TO HANGER SUPPORT	01532	04
CB1	 CABIDEIRO/ESTANTE/RACK 778MM	11439	02
PX	 PUXADOR/PEGADOR/HANDLE	11440	02
AD	 ADESIVO/ADHESIVO/ADHESIVE	11429 (AVELÃ)	12
AD	 ADESIVO/ADHESIVO/ADHESIVE	11190 (AVELÃ)	32

Ferragens/ Herrajes/ Hardware escala (1:1)

LEGENDA	DESCRIÇÃO/DESCRIPCIÓN/DESCRIPTION	CÓDIGO	QUANT.
P7	 PARAFUSO/TORNILLO/SCREW 4X45	01318	44
P1	 PARAFUSO/TORNILLO/SCREW 3,5X12	01328	64
PR1	 PREGO/CLAVO/NAIL 10X10	01330	220
C2	 CAVILHA/TARUGO/DOWEL 6X30 MM	01211	26
P13	 PARAFUSO/TORNILLO/SCREW 3,5X16	10224	04
C3	 CAVILHA/TARUGO/DOWEL 6X50 MM	01212	02
Pr2	 PREGO/CLAVO/NAIL 13X15	01329	16
P6	 PARAFUSO/TORNILLO/SCREW 4X40	02351	16
P12	 PARAFUSO/TORNILLO/SCREW 3,5X13	09927	128
M2	 PARAFUSO/TORNILLO/SCREW MINIFIX TAMBOR/BOLT MINIFIX	06999	09

