

Item	Caixa Caja Box	Qtd Ctd Qty	Descrição   Descripción   Description	Medidas (mm)   Dimensions (mm)   Size (measurements) (mm)
01	1/2	01	Rodapé frontal   Rodapié frontal   Front footboards	1599x120x12
02	1/2	01	Travessa do rodapé   Carril pie   Footboard tray	435x120x12
03	1/2	01	Rodapé traseiro   Rodapié trasero   Rear footboard	1599x122x12
04	1/2	01	Base   Base   Base	1599x465x15
05	2/2	01	Divisão esquerda   División izquierda   Left division	1730x435x12
06	2/2	01	Divisão direita   División derecha   Right division	1730x435x15
07	1/2	01	Moldura frontal   Cornija frontal   Front frame	525x80x12
08	1/2	01	Tampo das gavetas   Tapa de los cajones   Drawers cover	525x435x12
09	1/2	01	Prateleira   Estante   Shelf	525x350x12
10=13	1/2	01	Moldura Inferior Superior   Cornija Inferior Superior   Top Bottom Frame	379x88x15
11	1/2	02	Moldura lateral   Cornija lateral   Side frame	927x73x15
12	2/2	01	Espelho   Espejo   Mirror	750x400x3
13=10	1/2	01	Moldura Inferior Superior   Cornija Inferior Superior   Top Bottom Frame	379x88x15
14	1/2	01	Lateral esquerda   Lateral izquierda   Left side	1950x465x15
15	1/2	03	Prateleira fixa   Estante fija   Fixed shelf	525x350x12
16	1/2	01	Lateral direita   Lateral derecha   Right side	1950x465x15
17	1/2	01	Prateleira do varão   Hombre estante   Rail shelf	525x200x12
18	1/2	01	Tampo   Tapa   Top	1599x465x15
19	2/2	01	Chapéu   Sombrero   Hat	1627x100x15
20	2/2	02	Fundo   Fondo   Bottom	1760x538x3
21	2/2	01	Fundo menor   Fondo menos   Smaller bottom	536x212x3
22	2/2	01	Fundo cru   Fondo sin procesar   Raw bottom	603x536x3
23	2/2	02	Porta   Puerta   Door	1715x501x12
24	1/2	03	Frente de gaveta   Frente del cajón   Drawer front	518x136x12
25	1/2	06	Lado de gaveta   Lado del cajón   Drawer side	350x100x12
26	2/2	03	Ripa de trás   Listón trasero   Rear batten	500x100x12
27	2/2	03	Fundo de gaveta   Fondo del cajón   Drawer bottom	499x367x3



Ind. e Com. de Móveis Henn  
Mondai - SC - Brasil

+55 49 3674.3500

@moveishenn  
www.henn.com.br

INSTRUÇÕES DE MONTAGEM

INSTRUCCIONES DE MONTAJE  
ASSEMBLY INSTRUCTIONS

Roupeiro 02 Portas Deslizantes 03 Gavetas |  
Ropero 02 Puertas Deslizantes 03 Cajones | Wardrobe 02 Sliding Doors 03 Drawers

- B65-110 Rústico/Rústico/OFF White
- B65-117 Café/Café/OFF White

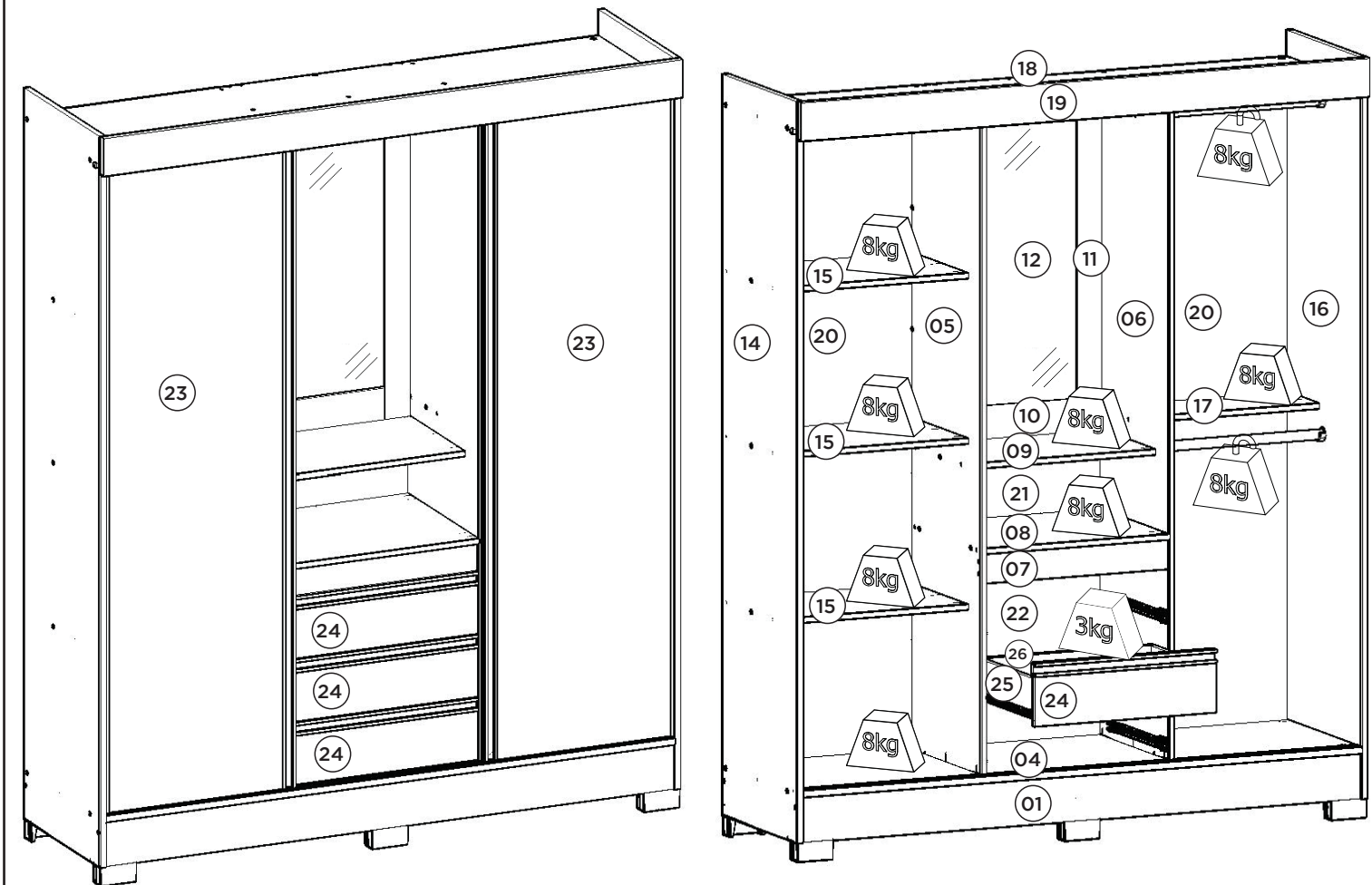

Ferragens | Herrajes | Hardware

<b>A</b> Parafuso 4,5x50mm CHT. Tornillo 4,5x50mm CHT. Screw 4,5x50mm CHT.	<b>B</b> Parafuso 3,5x40mm CHT. Tornillo 3,5x40mm CHT. Screw 3,5x40mm CHT.	<b>C</b> Parafuso 3,5x12mm FLA. Tornillo 3,5x12mm FLA. Screw 3,5x12mm FLA.	<b>D</b> Parafuso 3,5x12mm CHT. Tornillo 3,5x12mm CHT. Screw 3,5x12mm CHT.	<b>E</b> Parafuso 3,0x16mm CHT. Tornillo 3,0x16mm CHT. Screw 3,0x16mm CHT.	<b>F</b> Cavilha 5x25mm Cinta 5x25mm Dowel 5x25mm
<b>G</b> Prego 12x12mm Anelado Clavo 12x12mm Anillado Ringed Nails 12x12mm	<b>H</b> Prego 10x10mm Clavo 10x10mm Nail 10x10mm	<b>I</b> Fixador de fundos Fijador de fondos Bottom fixer	<b>J</b> Cantoneira plástica Cantenera plástica Plastic angle brackets	<b>K</b> Porca cilíndrica Tuerca cilíndrica Cylindrical nut	<b>L</b> Suporte de metal Soporte de metal Metal stands
<b>M</b> Suporte cabideiro Soporte de percha Coat hanger support	<b>N</b> Cabideiro Madeira 519mm Cabezal Madera 519mm 519mm wooden hanger	<b>O</b> Corrediza metal 350mm Corredera de metal 350mm Sliding metal 350mm	<b>P</b> Kit Roldana JM300 (2Portas) Kit Roldán JM300 (2Puertas) JM300 Pulley Kit (2Doors)	<b>Q</b> Puxador Plástico 12mm-1715mm Tirador Plástico 12mm-1715mm Plastic handle 12mm-1715mm	<b>R</b> Puxador Plástico 12mm-518mm Tirador Plástico 12mm-518mm Plastic handle 12mm-518mm
<b>S</b> Trilho Alumínio 1598mm Riel Alumínio 1598mm 1598mm aluminum rails	<b>T</b> Trilho PVC 1598mm Carril PVC 1598mm 1598mm PVC rails	<b>U</b> Pé "U" 50x40x100mm Pie "U" 50x40x100mm 50x40x100mm "U" feet	<b>V</b> Perfil Anti-empeno 1715mm Perfil anti-empeno 1715mm Anti-warp profile U 1715mm	<b>W</b> Sachê de cola Bolsa de pegamento Glue bag	<b>X</b> Adesivo tapa parafuso 10mm Adhesivo tapón de tornillo 10mm Bolt cover adhesive 10mm
<b>Y</b> Etiqueta resinada Briz Etiqueta resinada Briz Briz resin label					

Requisitos para montagem  
Requisitor para la montaje  
Assembly Requirements

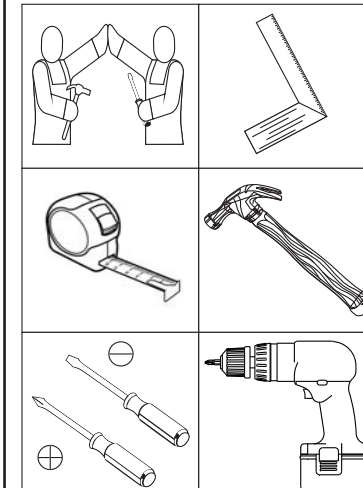

Imagens meramente ilustrativas  
Imágenes meramente ilustrativas  
Images for illustration only

Pesos máximos recomendados com carga distribuída  
Peso máximo recomendado con la carga distribuida  
Recommended maximum weights with evenly distributed.

**AVISO**  
Para limpeza de seu móvel, use uma flanela seca ou umedecida, e não utilize produtos químicos que possam danificar seu produto.

**SISTEMA DE MONTAGEM**  
O sistema de montagem dos produtos, funciona de acordo com a ordem crescente dos números indicados no desenho. Ex.: 01, 02, 03, 04... até a conclusão da montagem.

**ADVERTENCIA**  
Para limpieza de su móvil, use una flanela seca o húmeda, y no utilice productos químicos que puedan dañar su producto.

**SISTEMA DE MONTAJE**  
El sistema de montaje de los productos funciona de acuerdo con el orden creciente de los números indicados en el dibujo. Ej.: 01, 02, 03, 04... hasta la conclusión del montaje.

**NOTICE**  
To clean your furniture, use a dry or wet cloth, and do not use chemicals that may damage your product.

**ASSEMBLY SYSTEM**  
The products' assembly system works according to the increasing order of the indicated numbers. For example: 01, 02, 03, 04 ... to the end of the assembly.

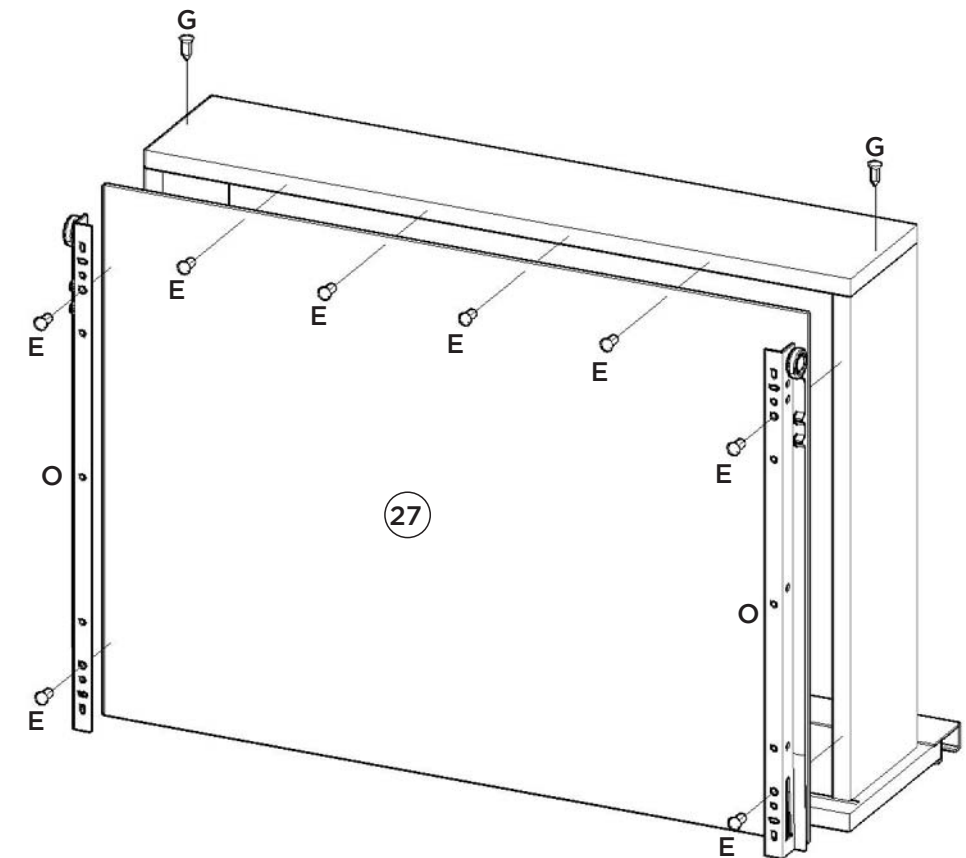
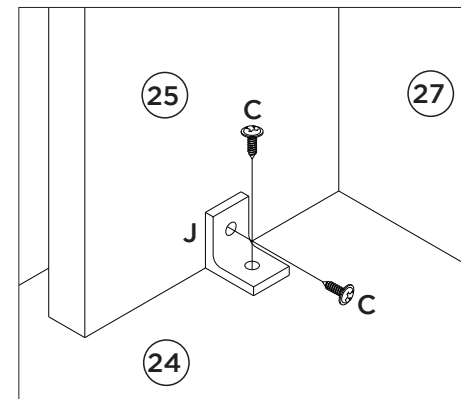
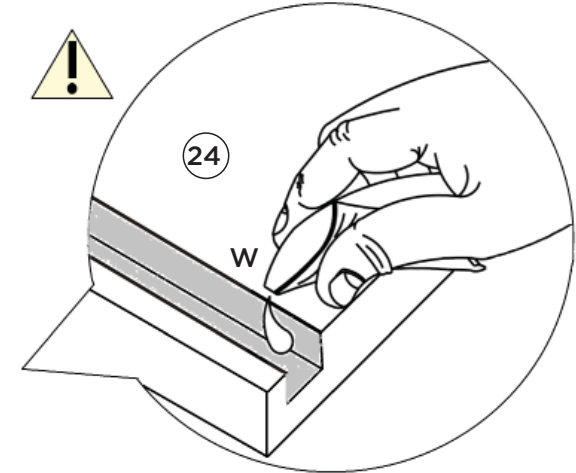
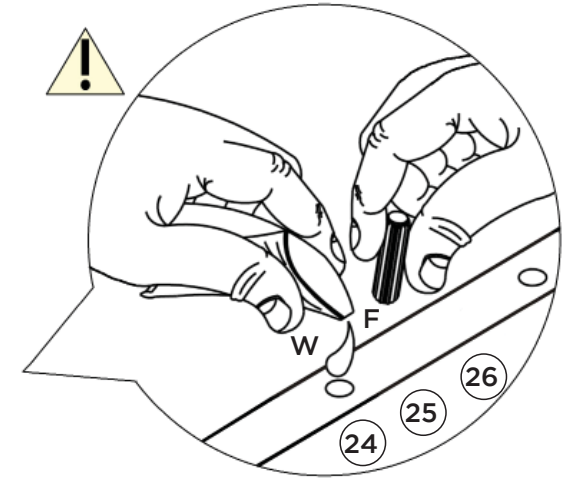
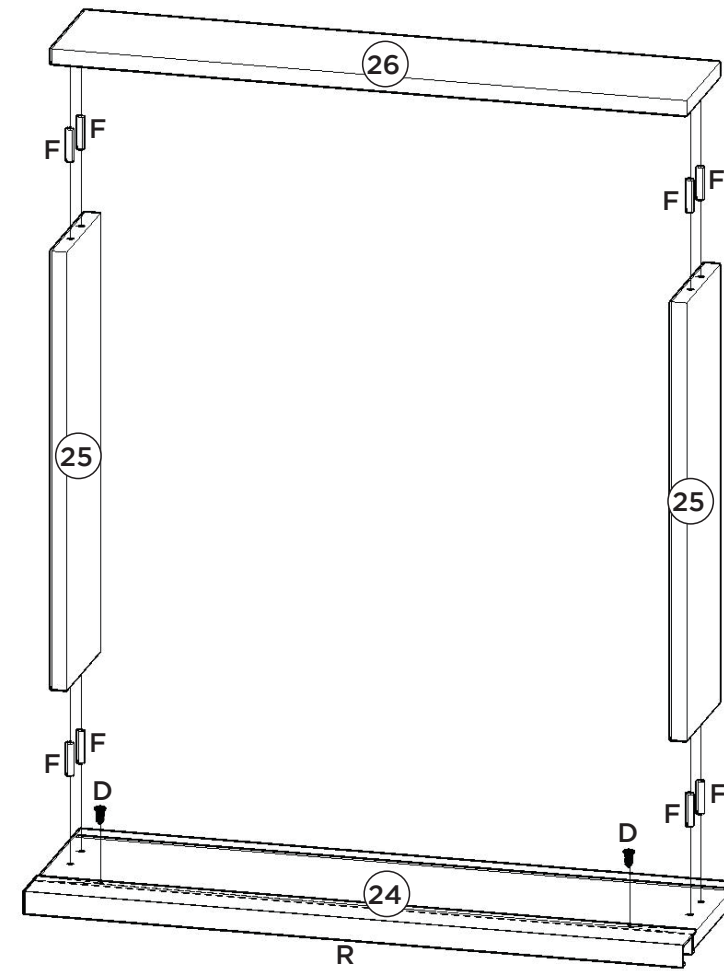
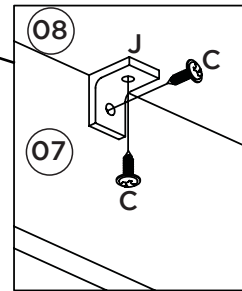
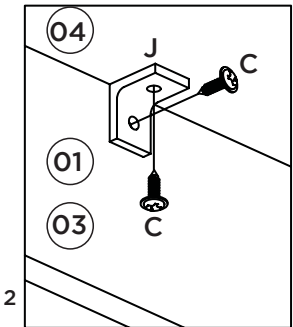
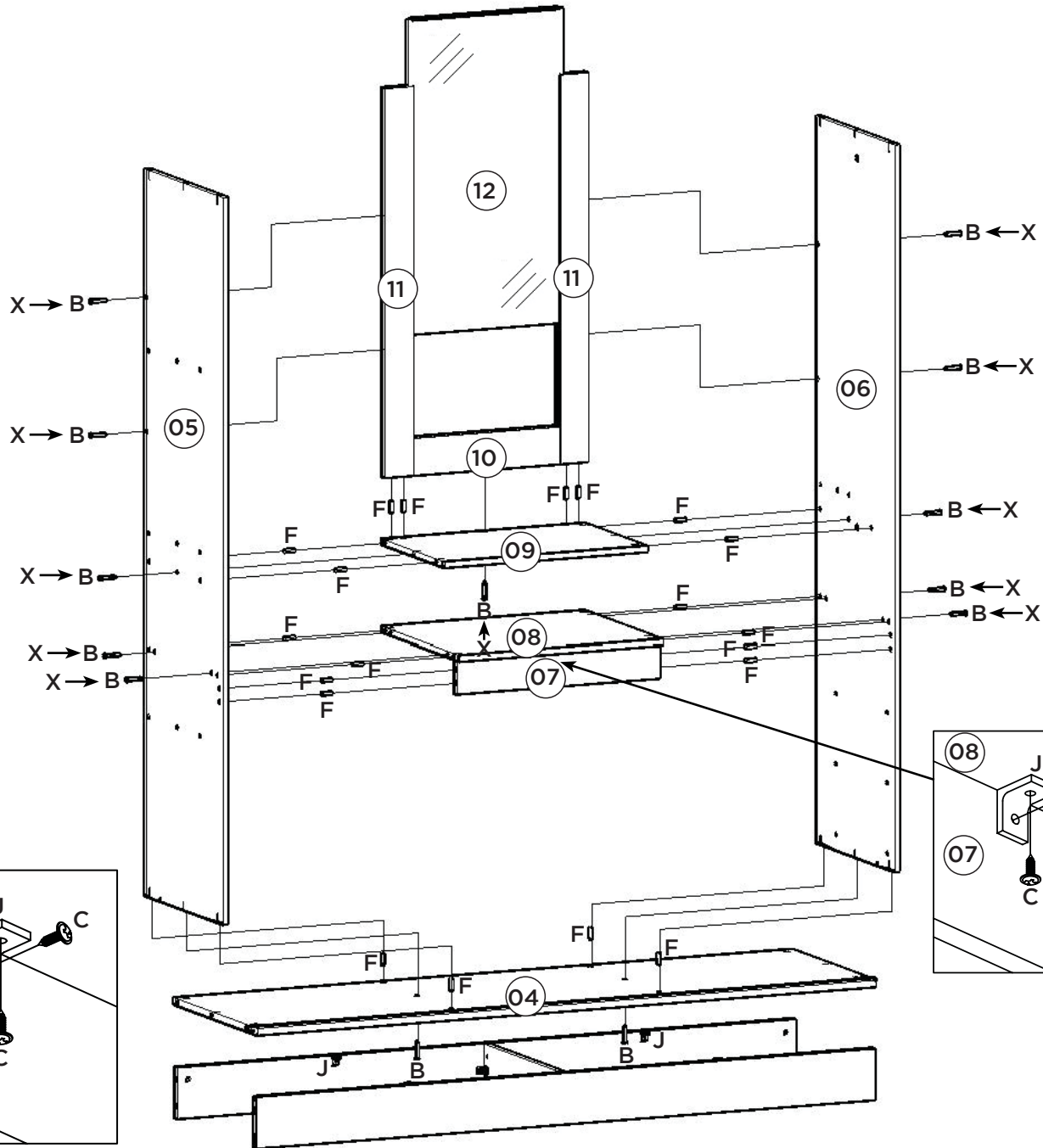
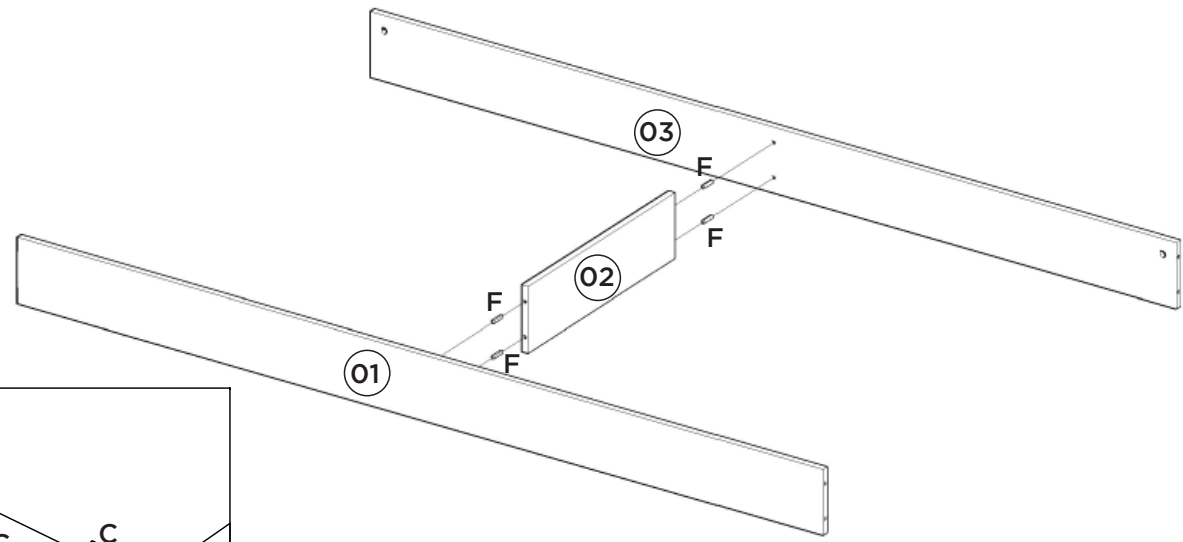
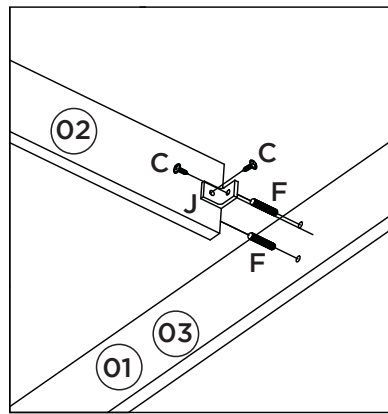

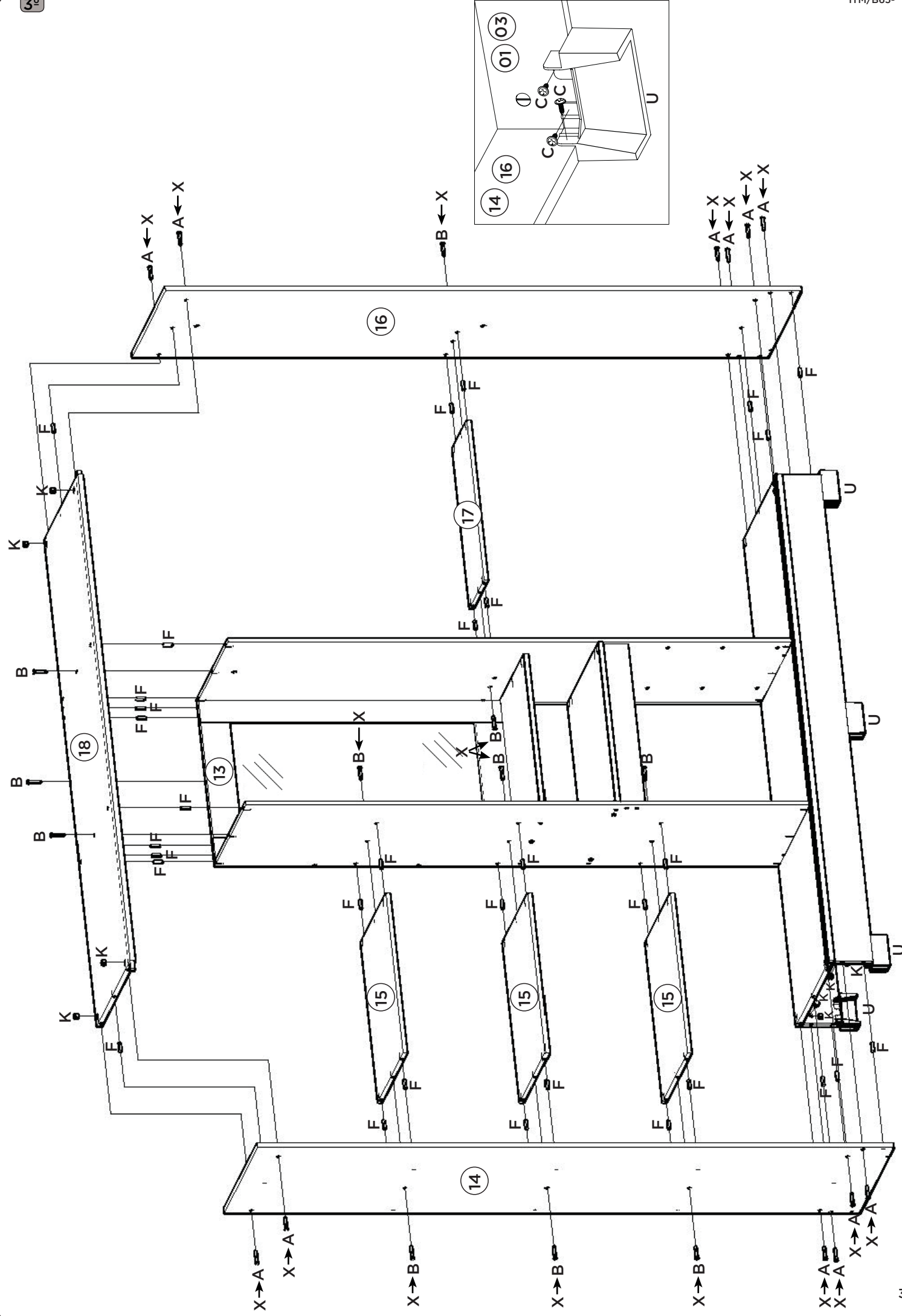
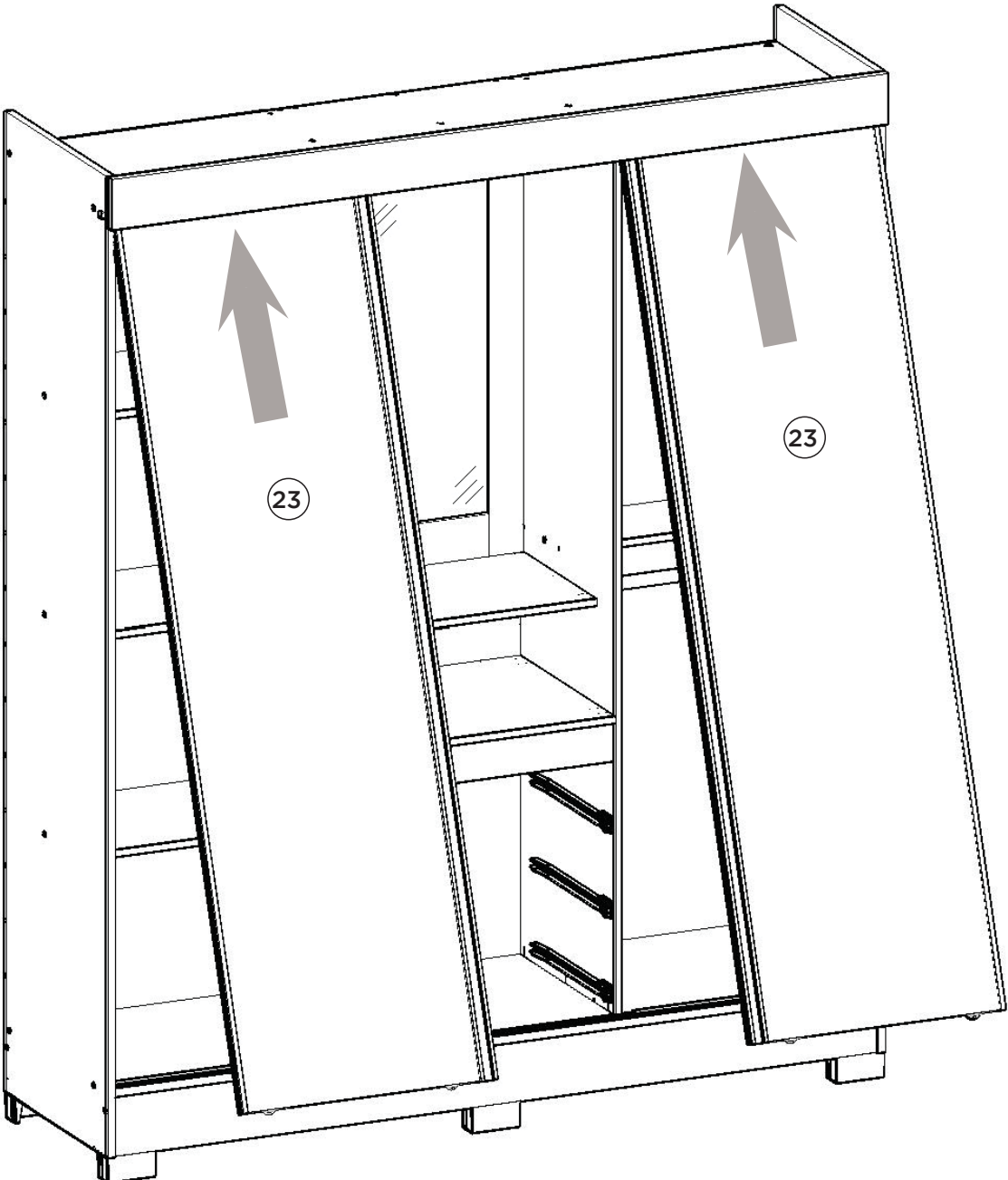
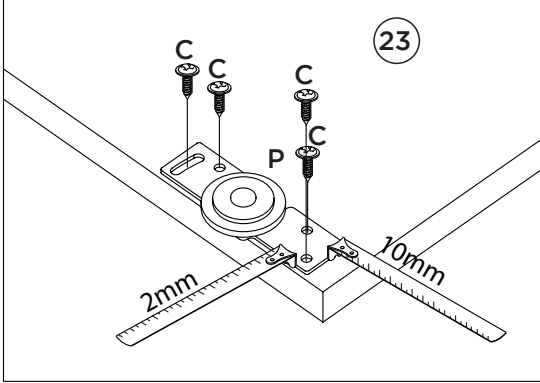
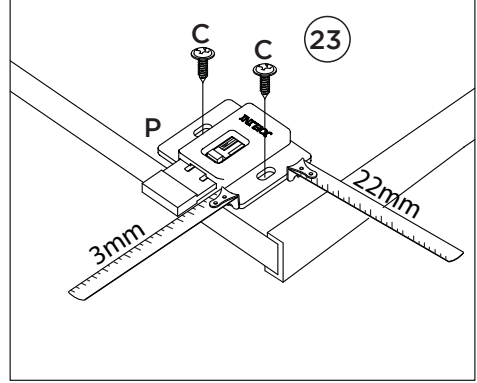
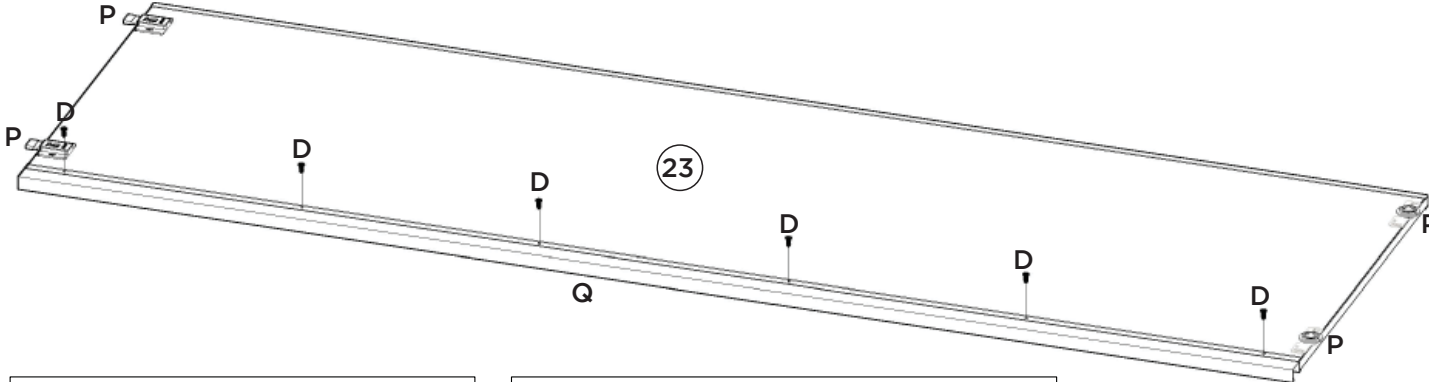

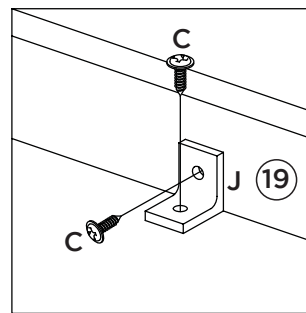

Fixar os pregos a uma distância de 120mm de um para outro.

Fijar las uñas a un distancia de 120 mm uno a otro.

Fix the nails at a distance of 120mm from one to the other

