

Roupeiro 02 Portas Deslizantes |
Ropero 02 Puertas Deslizantes | Wardrobe 02 Sliding Doors

- B70-10 Branco
- B70-18 Rústico/Branco

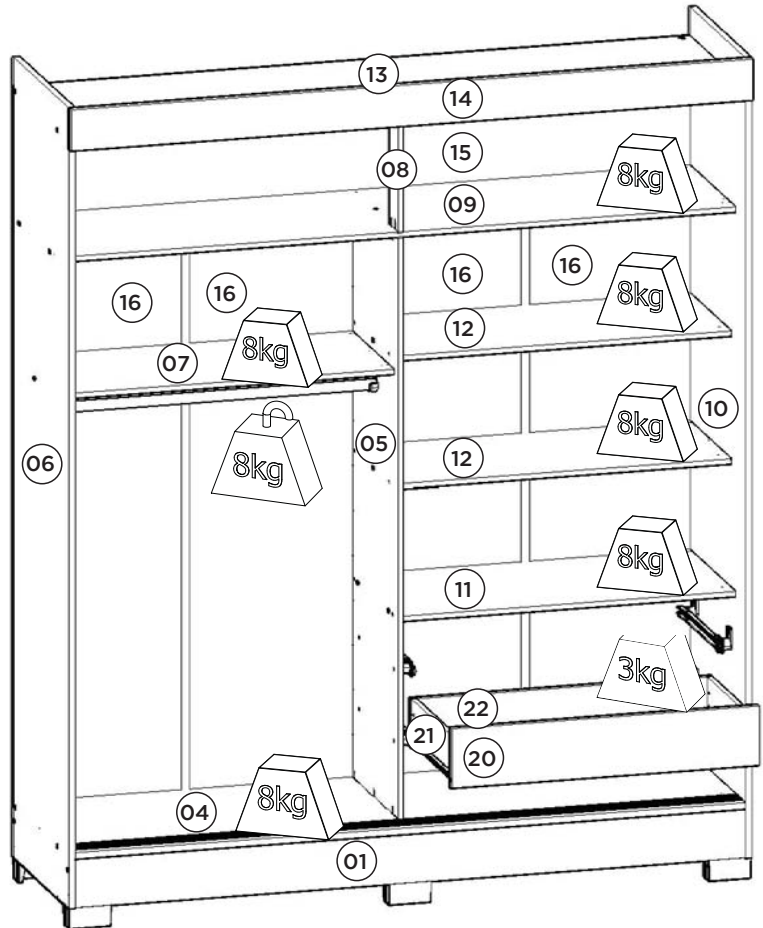

Requisitos para montagem
Requisitor para la montaje
Assembly Requirements

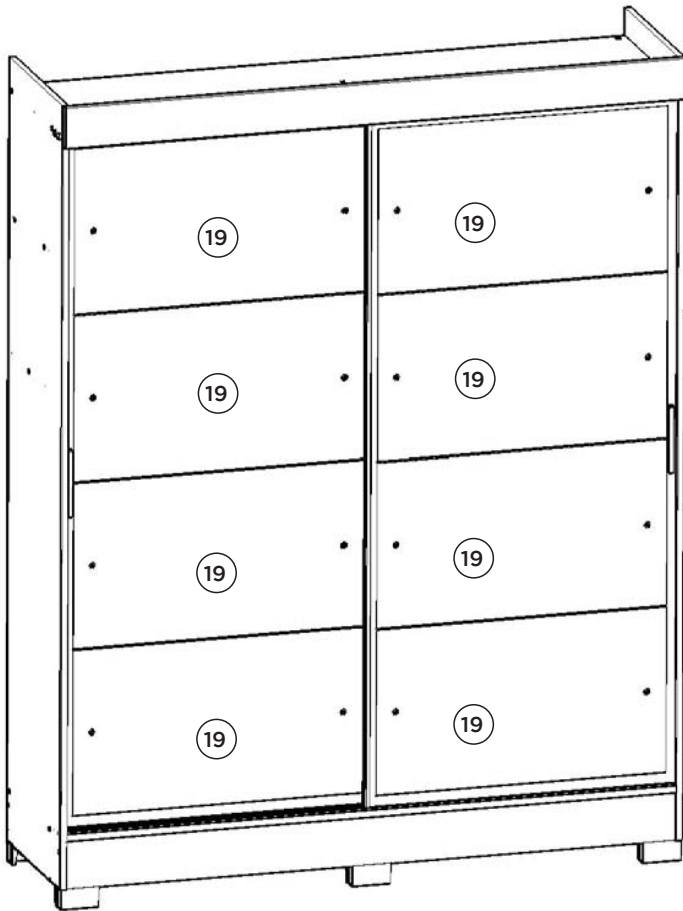
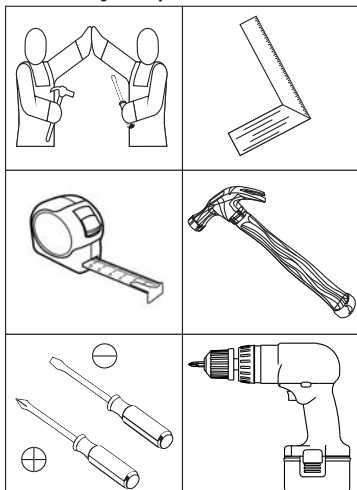

Imagens meramente ilustrativas
Imágenes meramente ilustrativas
Images for illustration only

Pesos máximos recomendados com carga distribuída
Peso máximo recomendado con la carga distribuida
Recommended maximum weights with evenly distributed.

AVISO

Para limpeza de seu móvel, use uma flanela seca ou umedecida, e não utilize produtos químicos que possam danificar seu produto.

SISTEMA DE MONTAGEM

O sistema de montagem dos produtos, funciona de acordo com a ordem crescente dos números indicados no desenho. Ex: 01, 02, 03, 04... até a conclusão da montagem.

ADVERTENCIA

Para limpieza de su móvil, use una flanela seca o húmeda, y no utilice productos químicos que puedan dañar su producto.

SISTEMA DE MONTAJE

El sistema de montaje de los productos funciona de acuerdo con el orden creciente de los números indicados en el dibujo. Ej.: 01, 02, 03, 04... hasta la conclusión del montaje.

NOTICE

To clean your furniture, use a dry or wet cloth, and do not use chemicals that may damage your product.

ASSEMBLY SYSTEM

The products' assembly system works according to the increasing order of the indicated numbers. For example: 01, 02, 03, 04 ... to the end of the assembly.

1°

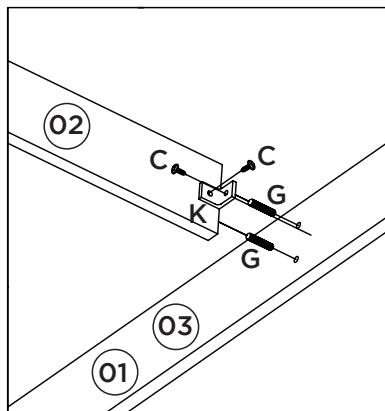
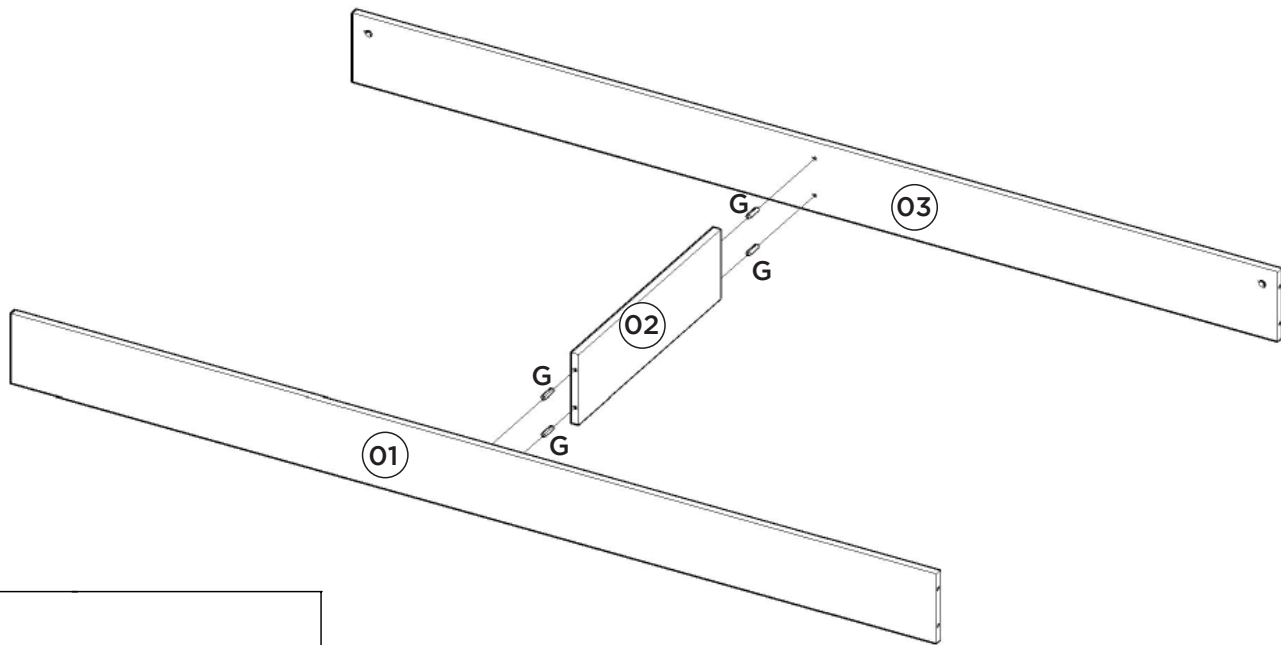

2°

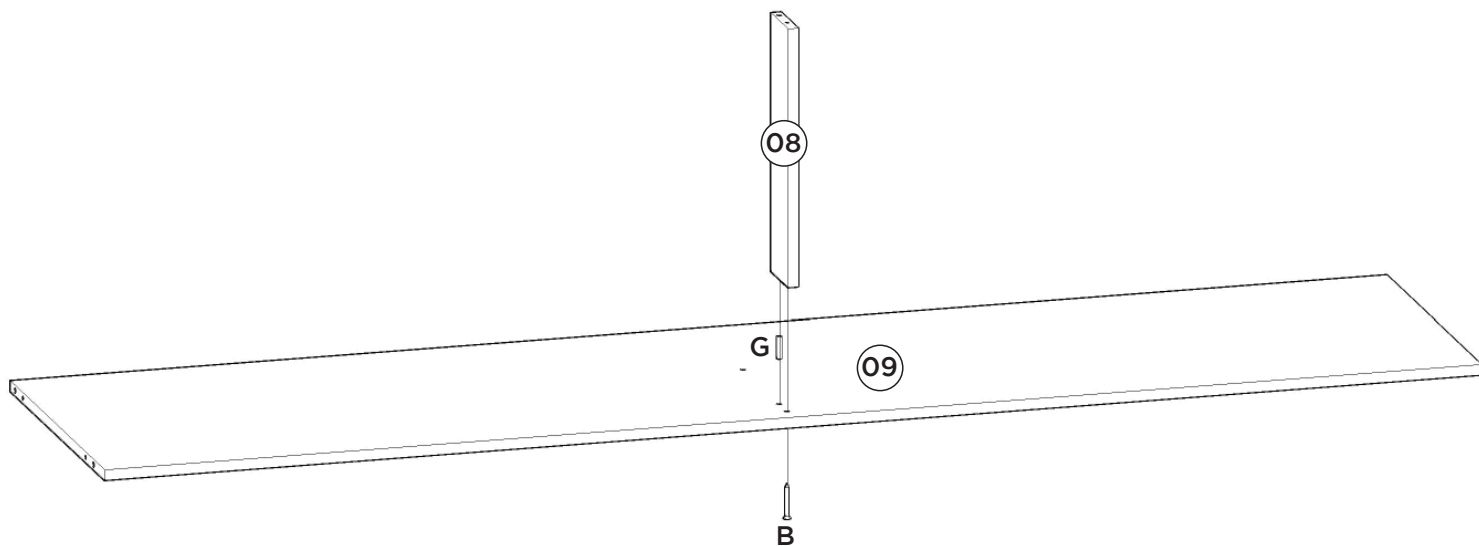

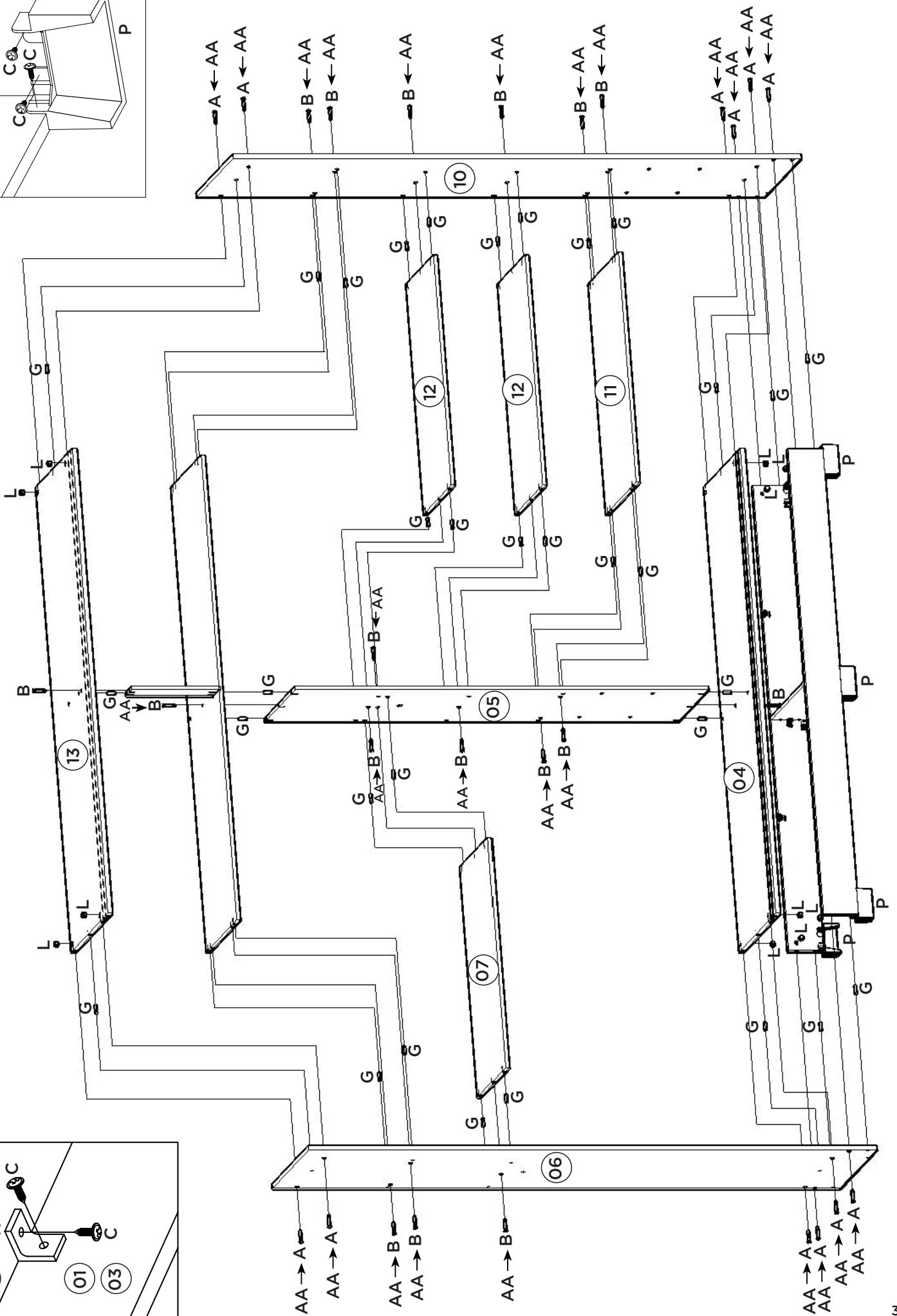
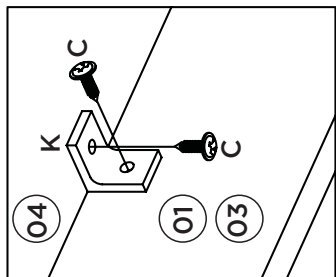
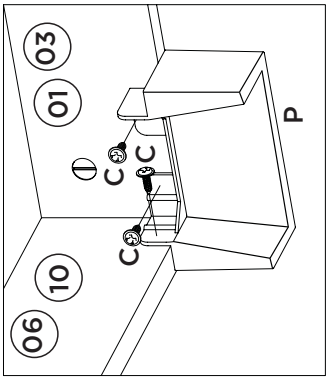

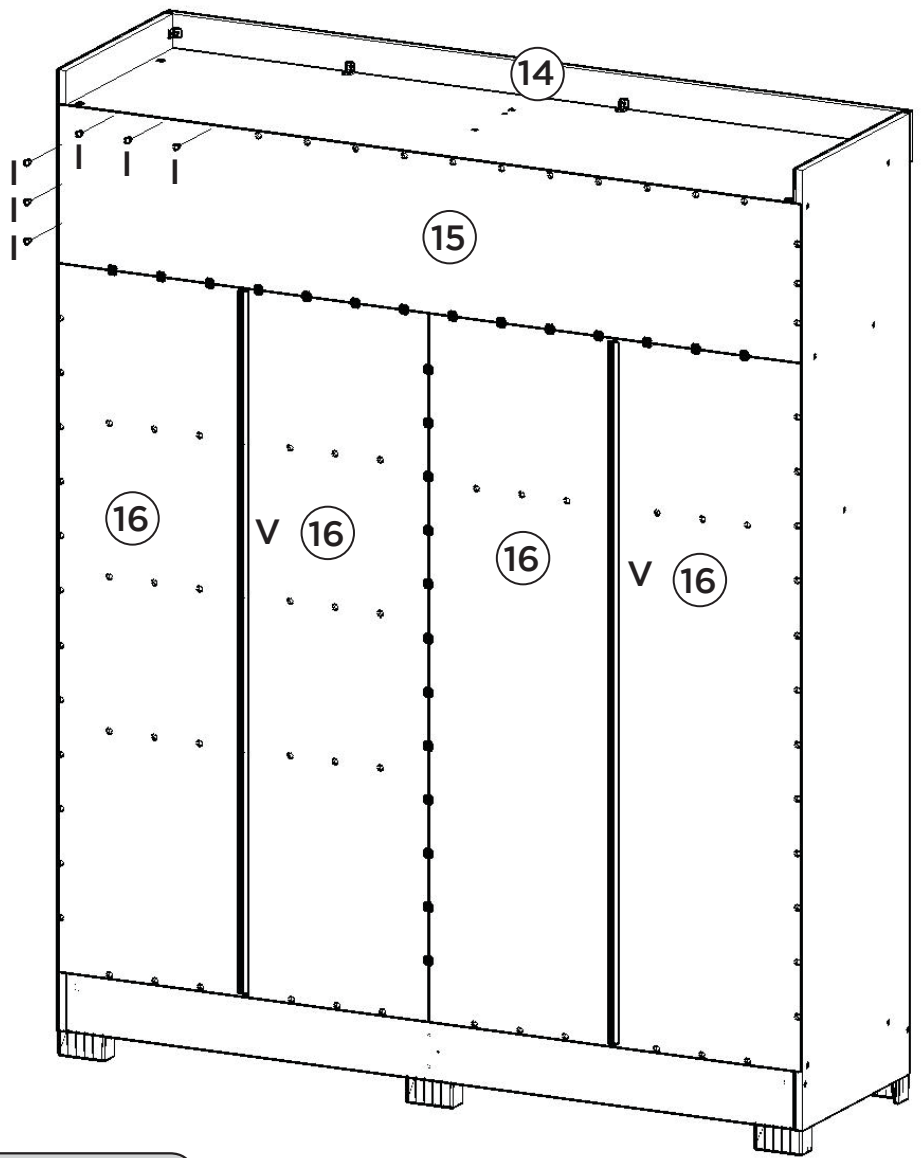
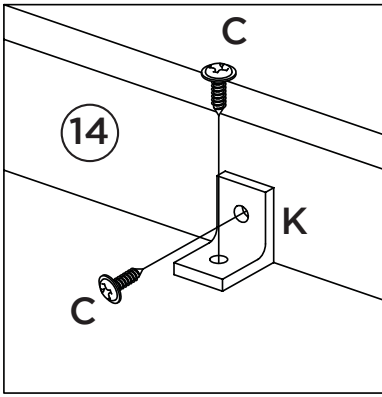

Fixar os pregos a uma distância de 120mm de um para outro.

Fijar las uñas a un distancia de 120 mm uno a otro.

Fix the nails at a distance of 120mm from one to the other

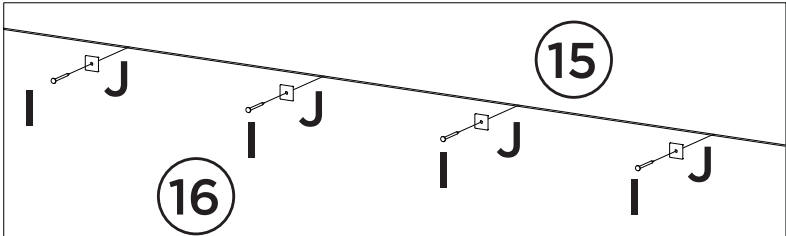
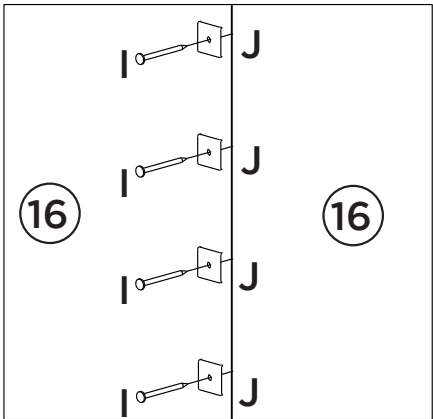
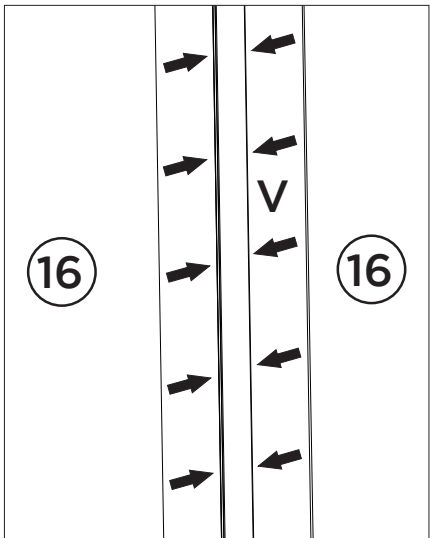

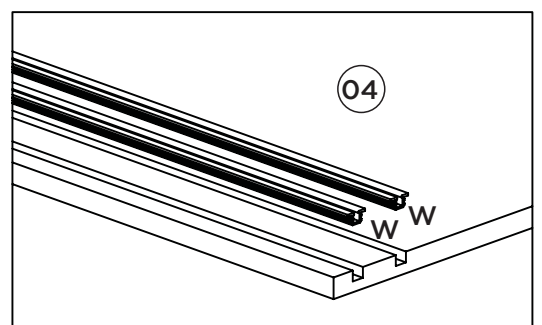
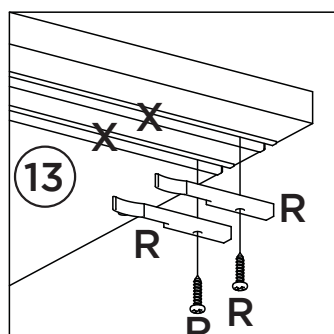
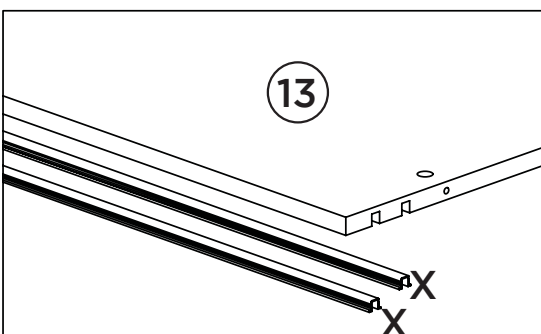
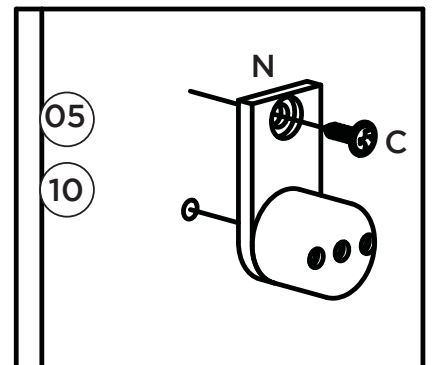
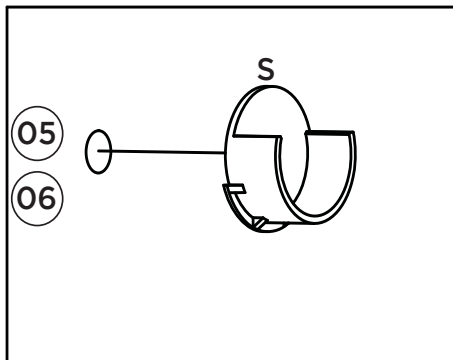
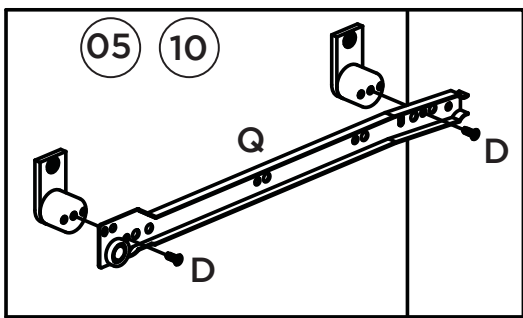
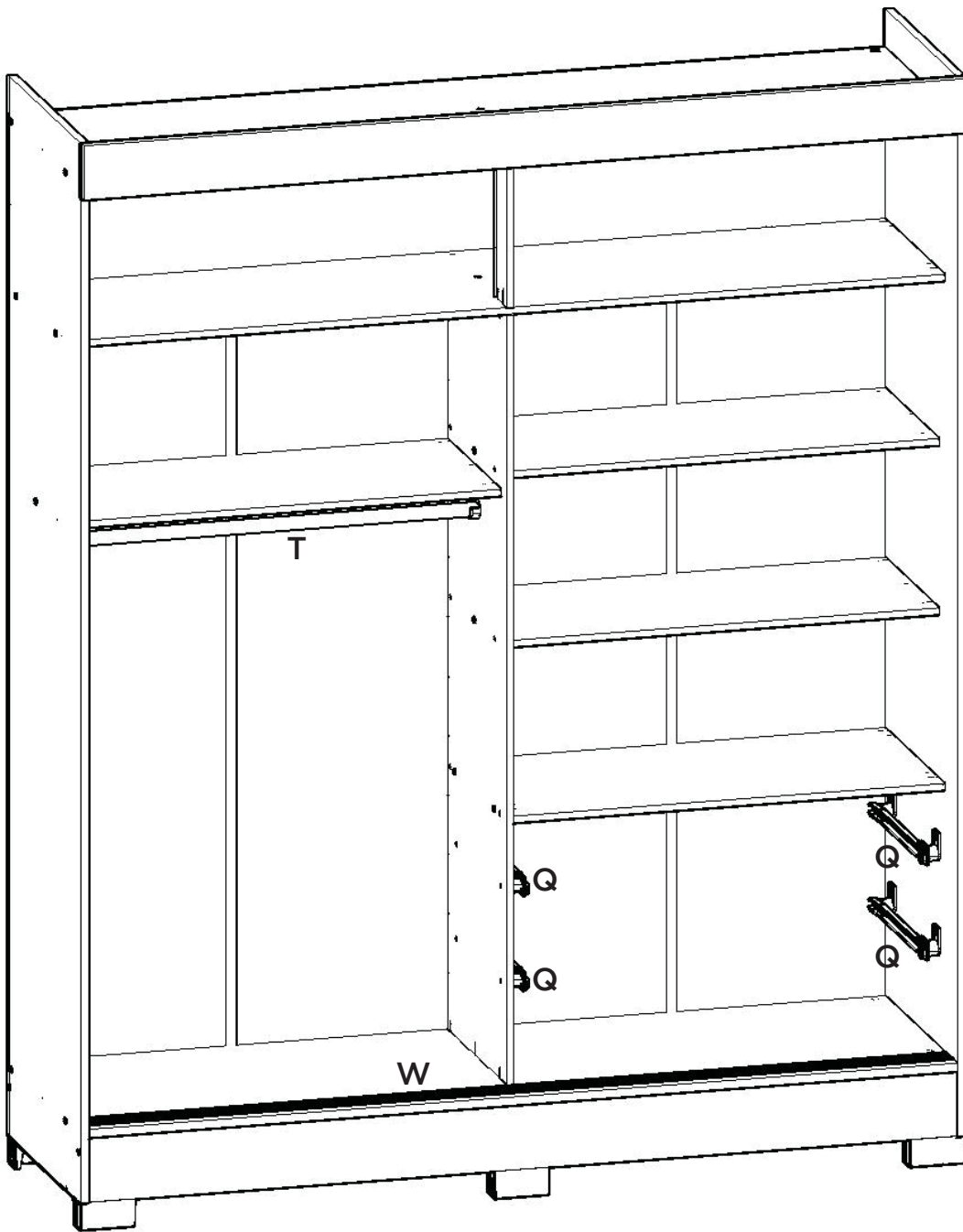

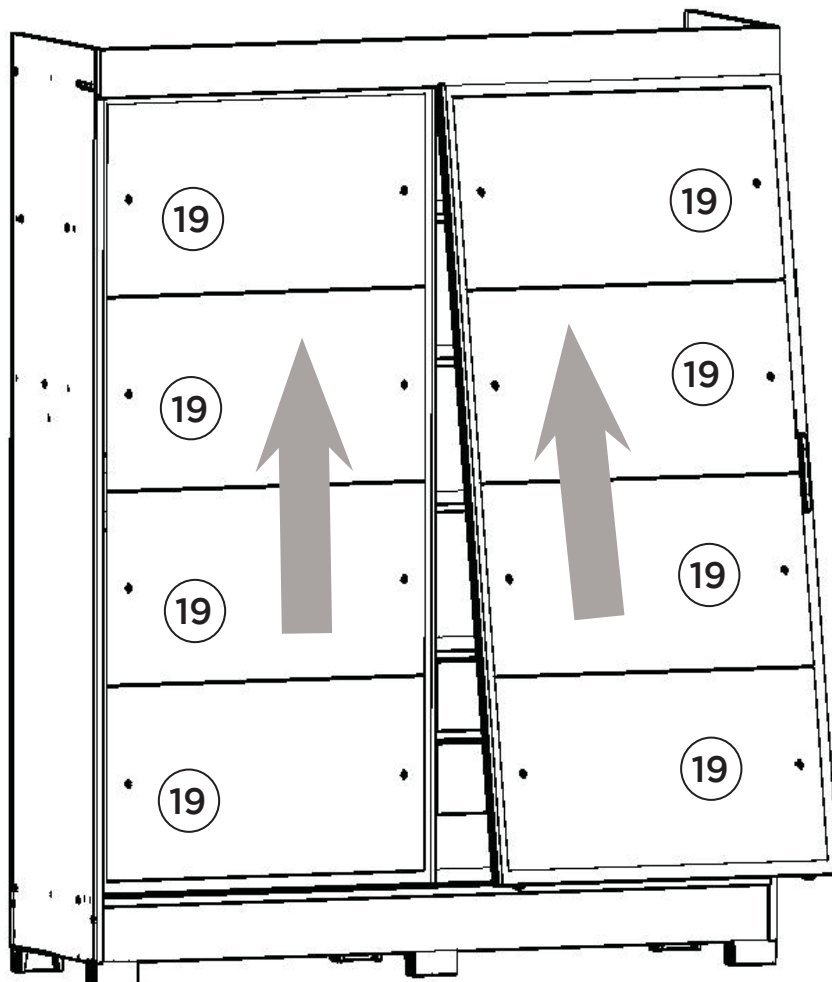
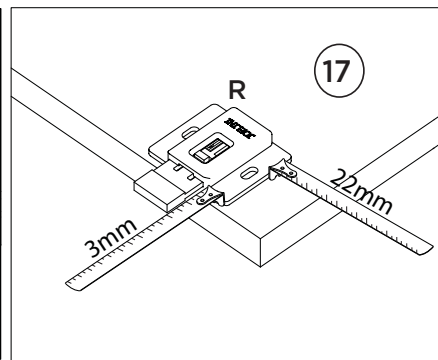
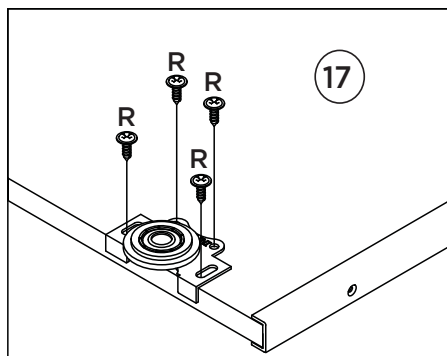
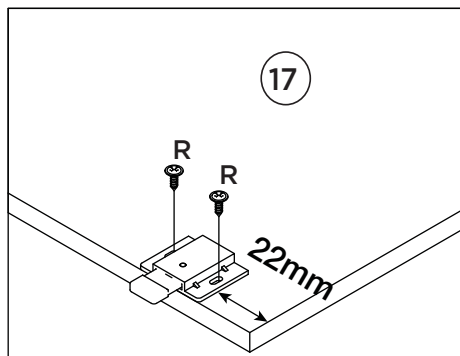
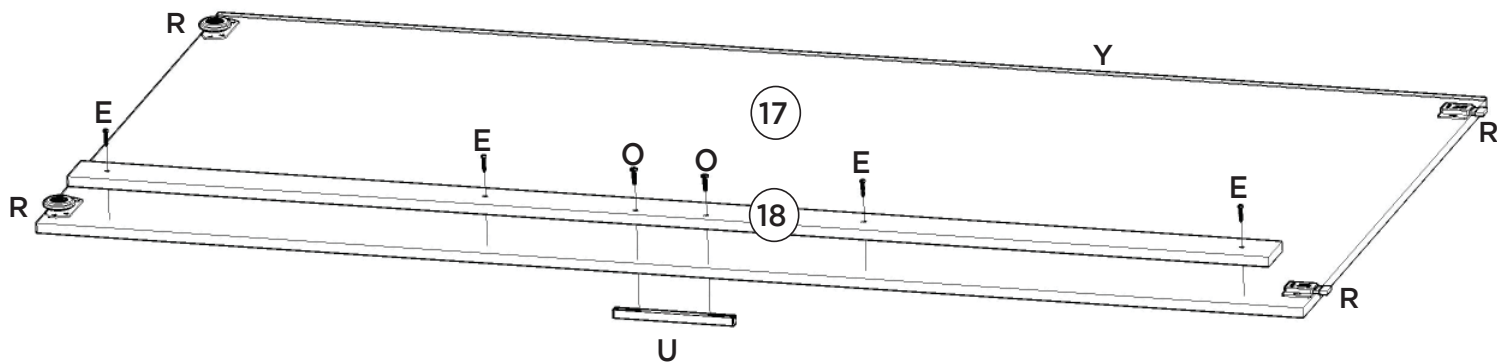

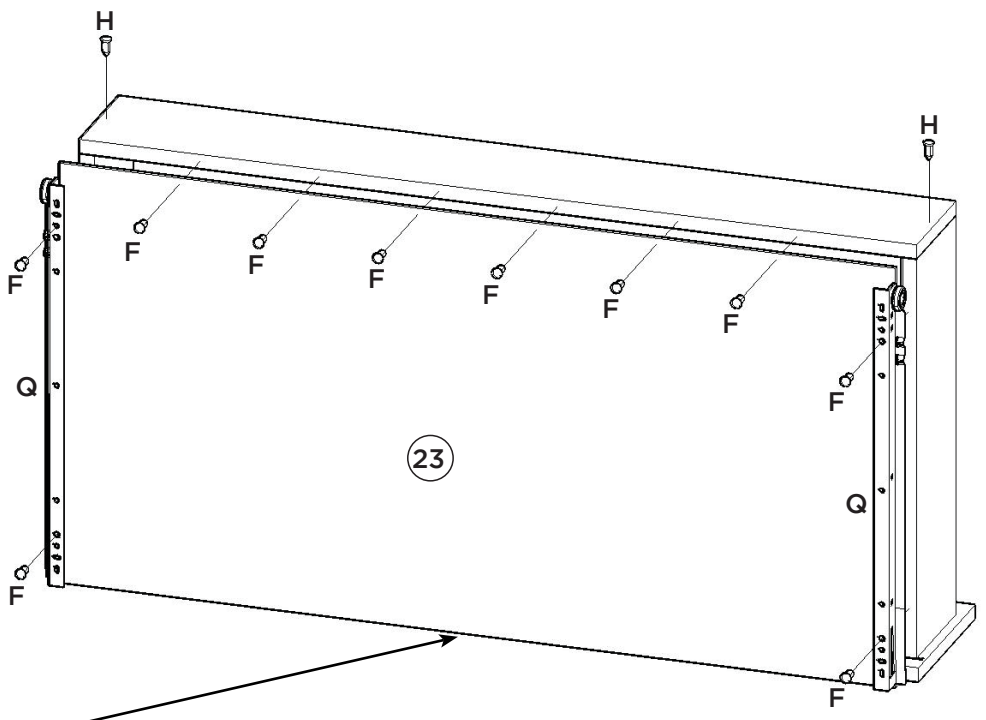
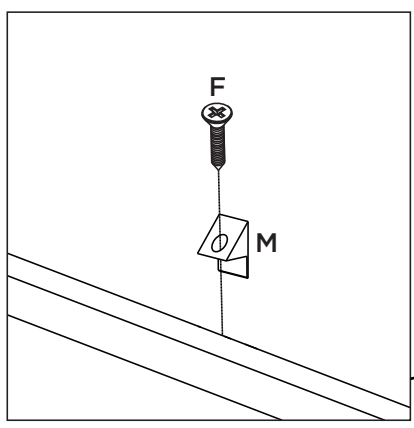
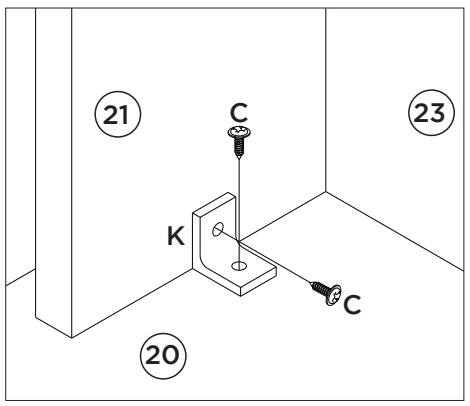
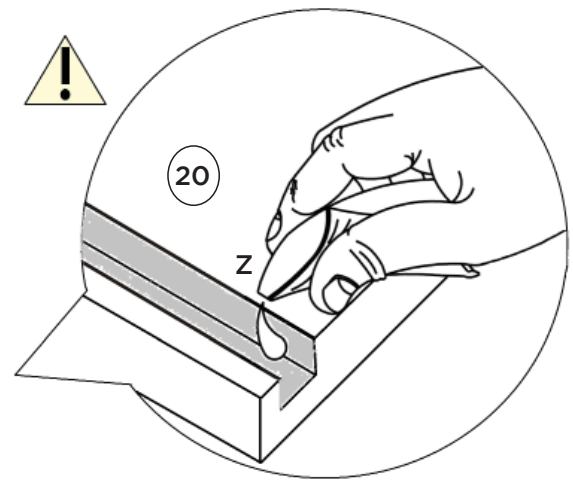
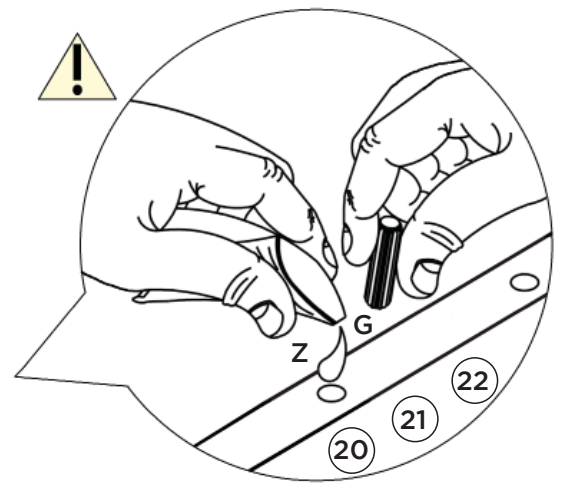
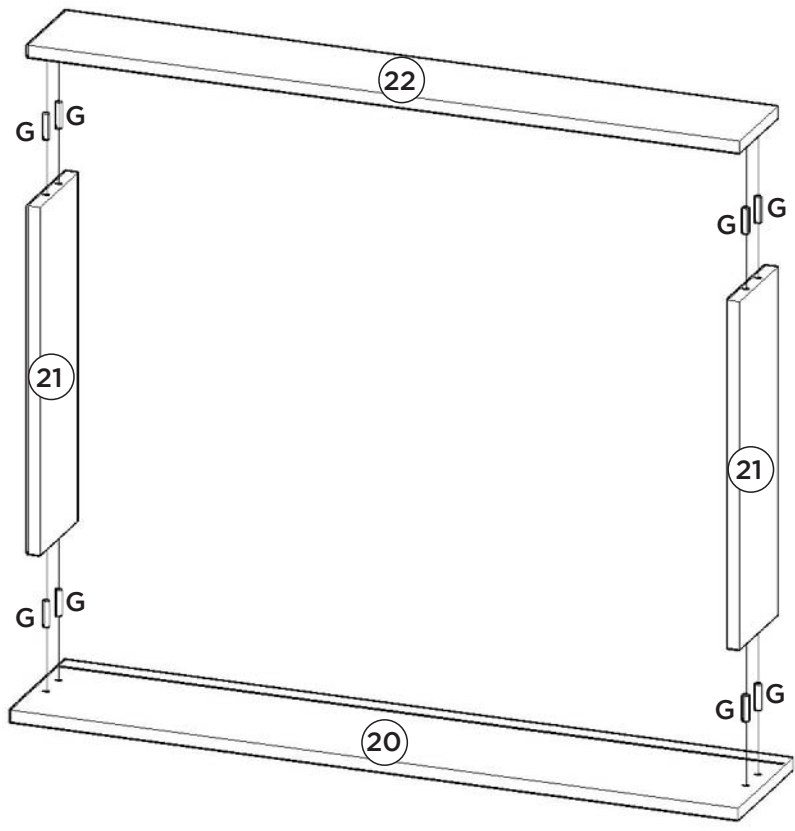









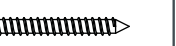



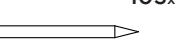
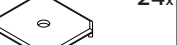
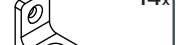





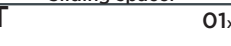
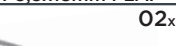

Item	Caixa Caja Box	Qty Ctd Qty	Descrição Descripción Description	Medidas (mm) Dimensions (mm) Size (measurements) (mm)
01	1/3	01	Rodapé frontal Rodapié frontal Front footboards	1599x120x12
02	1/3	01	Travessa do rodapé Carril pie Footboard tray	435x120x12
03	1/3	01	Rodapé traseiro Rodapié trasero Rear footboard	1599x120x12
04	2/3	01	Base Base Base	1599x465x15
05	2/3	01	Divisão División Division	1418x385x12
06	1/3	01	Lateral esquerda Lateral izquierda Left side	1950x465x15
07=12	2/3	01	Prateleira Estante Shelf	793x350x12
08	1/3	01	Ripa do maleiro Portaequipajes de ripa Lath of the closet top shelf	300x70x12
09	1/3	01	Chão do maleiro Piso del portaequipajes Floor of the closet top shelf	1599x385x12
10	1/3	01	Lateral direita Lateral derecha Right side	1950x465x15
11	2/3	01	Tampo da gaveta Tapa de lo cajone Drawer top	793x385x12
12=07	1/3	02	Prateleira Estante Shelf	793x350x12
13	2/3	01	Tampo Tapa Top	1599x465x15
14	1/3	01	Chapéu Sombrero Hat	1627x100x15
15	1/3	01	Fundo Superior Fondo Superior Superior background	1623x320x3
16	2/3	04	Fundo Fondo Bottom	1438x402x3
17	3/3	02	Porta de correr espelho Puerta de correr espejo Mirror sliding door	1715x812x12
18	1/3	02	Travessa Interna da Porta Travesaño de la puerta Internal Door Carriage	1625x60x12
19	3/3	08	Espelho Espejo Mirror	760x410x3
20	1/3	02	Frete de gaveta Frente del cajón Drawer front	735x145x12
21	1/3	04	Lado de gaveta Lado del cajón Drawer side	350x100x12
22	1/3 e 2/3	02	Ripa de trás Listón trasero Rear batten	718x100x12
23	1/3	02	Fundo de gaveta recortado Fondo de cajón recortado Drawer bottom trimmed	717x367x3

Ferragens | Herrajes | Hardware

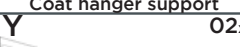
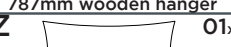
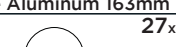
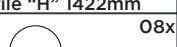
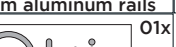
A  Parafuso 4,5x50mm CHT. Tornillo 4,5x50mm CHT. Screw 4,5x50mm CHT.	B  Parafuso 3,5x40mm CHT. Tornillo 3,5x40mm CHT. Screw 3,5x40mm CHT.	C  Parafuso 3,5x12mm FLA. Tornillo 3,5x12mm FLA. Screw 3,5x12mm FLA.	D  Parafuso 3,5x12mm CHT. Tornillo 3,5x12mm CHT. Screw 3,5x12mm CHT.	E  Parafuso 3,0x20mm PAN. Tornillo 3,0x20mm PAN. Screw 3,0x20mm PAN.	F  Parafuso 3,0x16mm CHT. Tornillo 3,0x16mm CHT. Screw 3,0x16mm CHT.
G  Cavilha 5x25mm Cinta 5x25mm Dowel 5x25mm	H  Prego 12x12mm Anelado Clavo 12x12mm Anillado Ringed Nails 12x12mm	I  Prego 10x10mm Clavo 10x10mm Nail 10x10mm	J  Fixador de fundos Fijador de fondos Bottom fixer	K  Cantoneira plástica Cantонера plástica Plastic angle brackets	L  Porca cilíndrica Tuerca cilíndrica Cylindrical nut
M  Cantoneira suporte triangular Cantонера soporte triangular Triangle support angle	N  Distanciador de corrediça Distanciador de deslizamiento Sliding spacer	O  Parafuso 3,5x18mm FLA. Tornillo 3,5x18mm FLA. Screw 3,5x18mm FLA.	P  Pé "U" 50x40x100mm Pie "U" 50x40x100mm 50x40x100mm "U" feet	Q  Corrediça metal 350mm Corredera de metal 350mm Sliding metal 350mm	R  Kit Roldana JM135R (2Portas) Kit Roldán JM135R (2Puertas) JM135R Pulley Kit (2Doors)
S  Suporte cabideiro Soporte de percha Coat hanger support	T  Cabideiro Madeira 787mm Cabezal Madera 787mm 787mm wooden hanger	U  Puxador Alumínio 163mm Tirador Aluminio 163mm Handle Aluminum 163mm	V  Perfil "H" 1422mm Perfil "H" 1422mm Profile "H" 1422mm	W  Trilho Alumínio 1598mm Riel Aluminio 1598mm 1598mm aluminum rails	X  Trilho PVC 1598mm Carril PVC 1598mm 1598mm PVC rails
Y  Perfil Anti-empeno 1715mm Perfil anti-empeno 1715mm Anti-warp profile U 1715mm	Z  Sachê de cola Bolsa de pegamento Glue bag	AA  Adesivo tapa parafuso 10mm Adhesivo tapón de tornillo 10mm Bolt cover adhesive 10mm	AB  Adesivo tapa parafuso 10mm Perfil Adhesivo tapón de tornillo 10mm Perfil Bolt cover adhesive 10mm Profile	AC  Etiqueta resinada Briz Etiqueta resinada Briz Briz resin label	

A ferragem "Y" só será usado em caso de pedido de assistência técnica, pois o perfil antiempeno "U" já vem montado nas portas de fábrica.

Hardware "Y" sólo se utiliza en caso solicitar asistencia técnica, para el perfil antiempeno "U" viene montados en las puertas de fábrica.

The hardware "Y" will only be used in the event of a technical assistance request, because the anti-warp profile "U" is already manufactured installed in the doors.