

HENN

Ind. e Com. de Móveis Henn
Mondáí - SC - Brasil

+55 49 3674.3500

@moveishenn
www.henn.com.br

INSTRUÇÕES DE MONTAGEM

INSTRUCCIONES DE MONTAJE
ASSEMBLY INSTRUCTIONS

Roupeiro Campeche 06 Portas | Armario Campeche 06 Puertas | Wardrobe Campeche 06 Doors

D207-94 Rústico
D207-101 Café

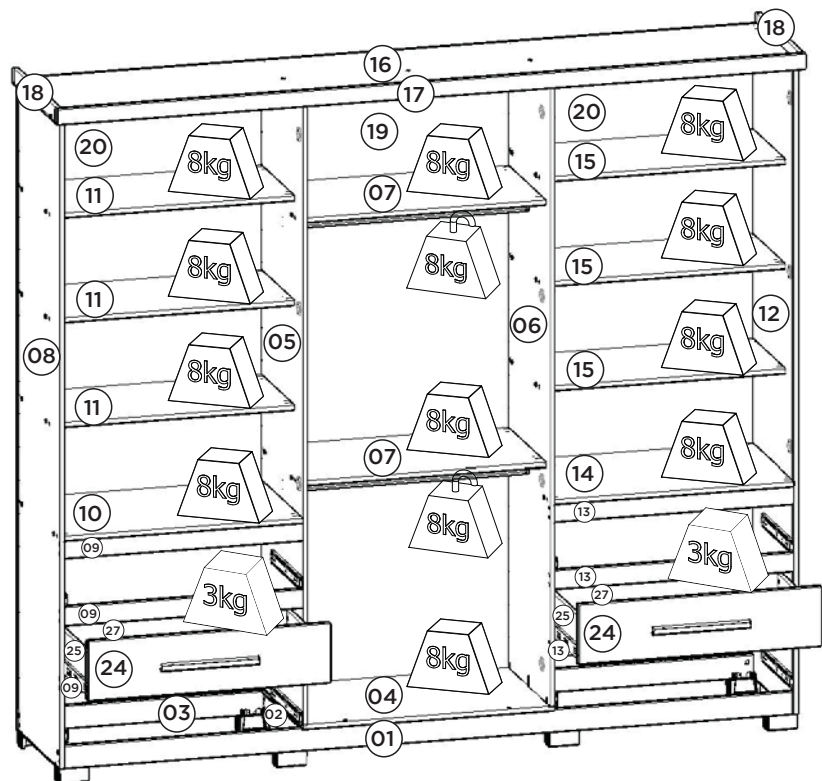
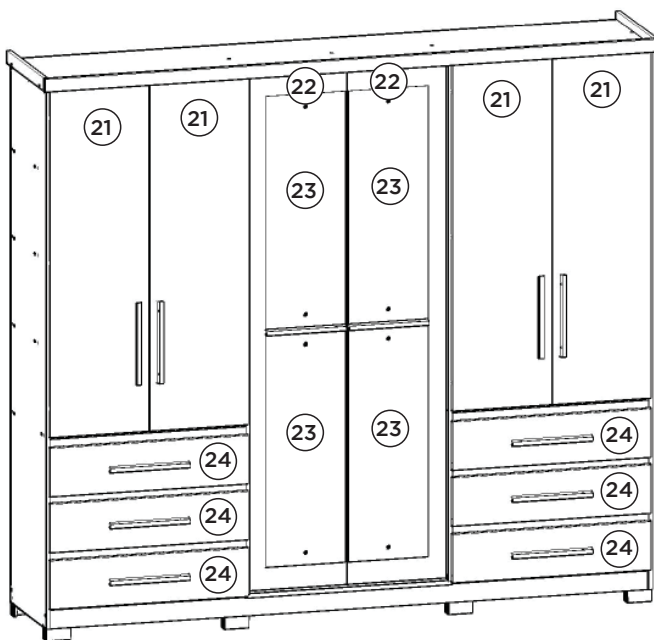

Pesos máximos recomendados com carga distribuída.
Peso máximo recomendado con la carga distribuida.
Recommended maximum weights with evenly distributed.

Requisitos para montagem Requisitor para la montaje Assembly Requirements

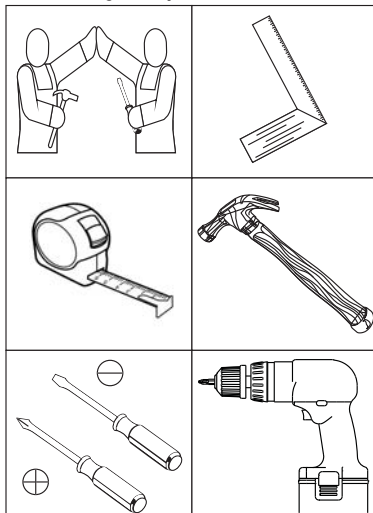

Imagens meramente ilustrativas
Imágenes meramente ilustrativas
Images for illustration only

AVISO

Para limpeza de seu móvel, use uma flanela seca ou umedecida, e não utilize produtos químicos que possam danificar seu produto.

SISTEMA DE MONTAGEM

O sistema de montagem dos produtos, funciona de acordo com a ordem crescente dos números indicados no desenho. Ex: 01, 02, 03, 04... até a conclusão da montagem.

ADVERTENCIA

Para limpieza de su móvil, use una flanela seca o húmeda, y no utilice productos químicos que puedan dañar su producto.

SISTEMA DE MONTAJE

El sistema de montaje de los productos funciona de acuerdo con el orden creciente de los números indicados en el dibujo. Ej.: 01, 02, 03, 04... hasta la conclusión del montaje.

NOTICE

To clean your furniture, use a dry or wet cloth, and do not use chemicals that may damage your product.

ASSEMBLY SYSTEM

The products' assembly system works according to the increasing order of the indicated numbers. For example: 01, 02, 03, 04 ... to the end of the assembly.

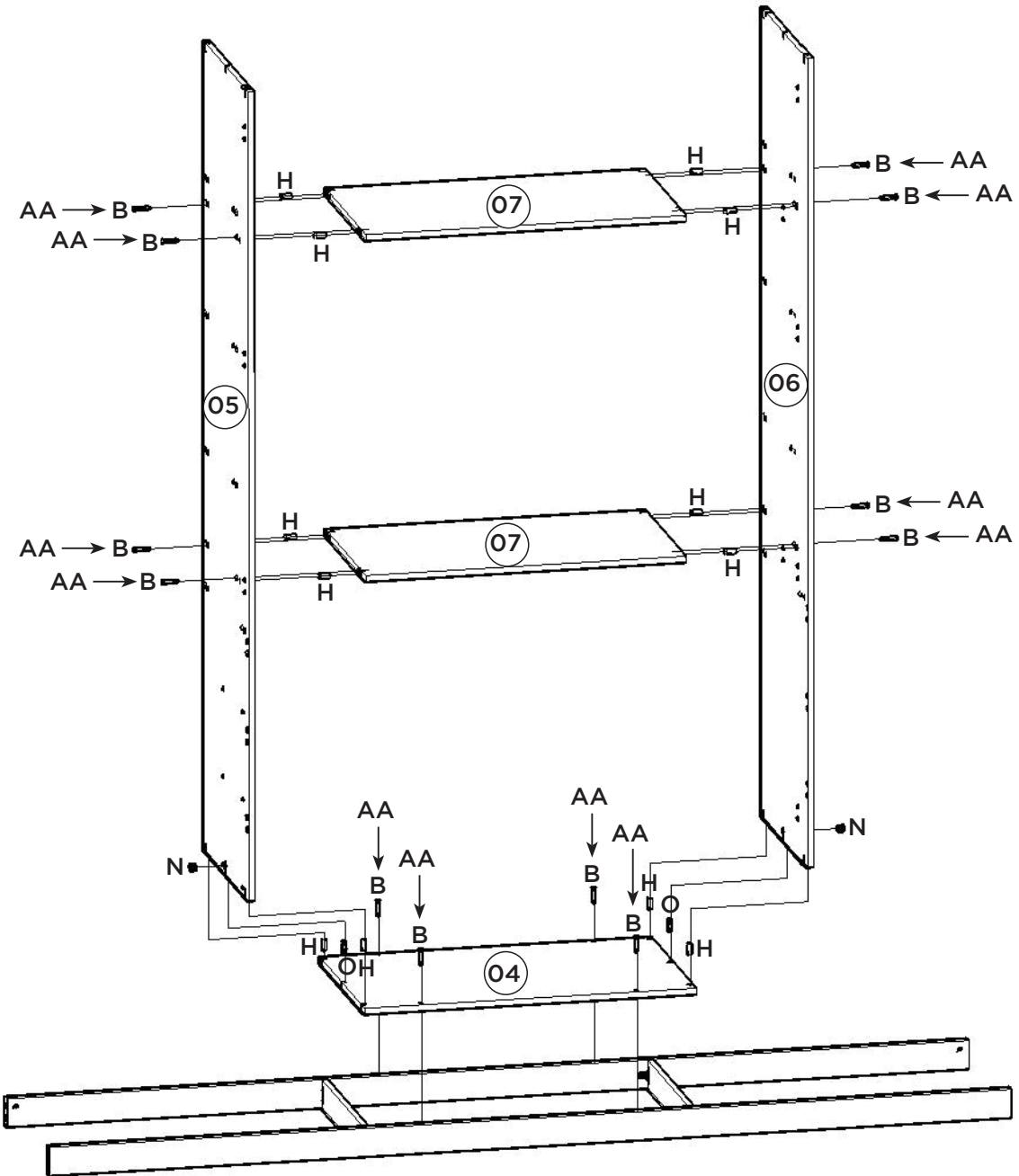
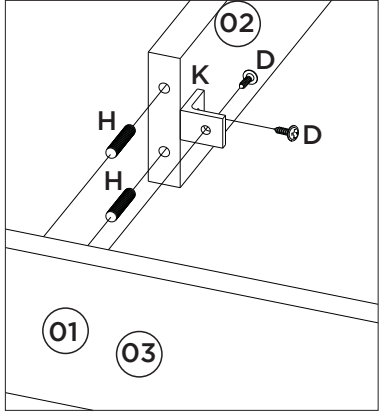
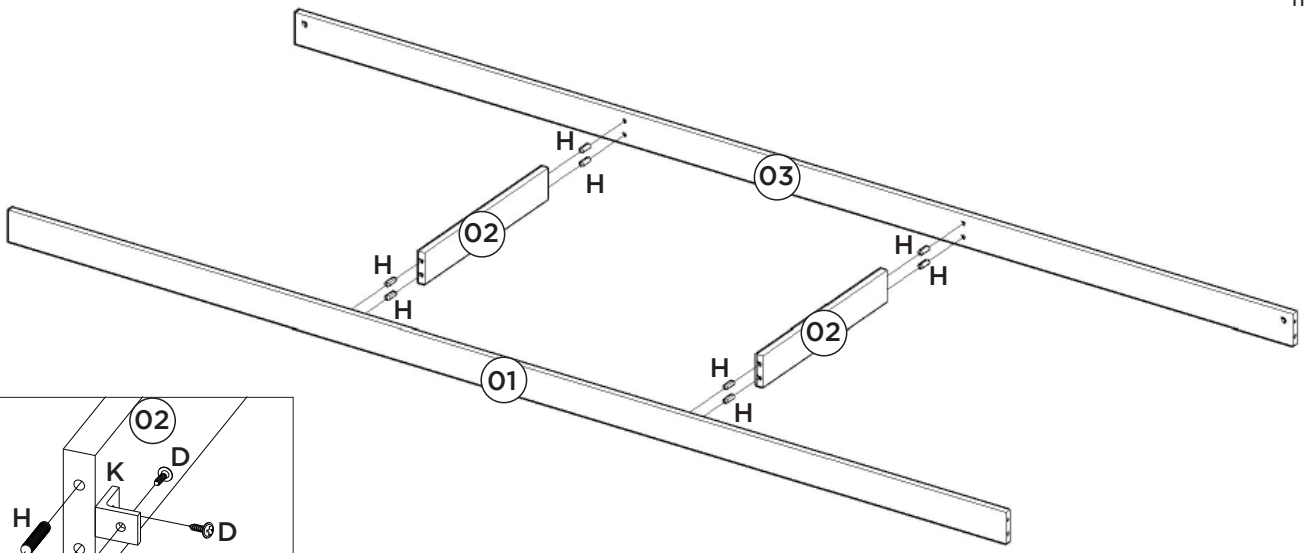

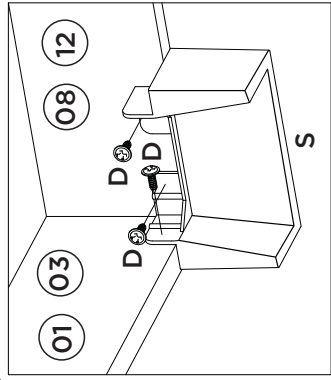
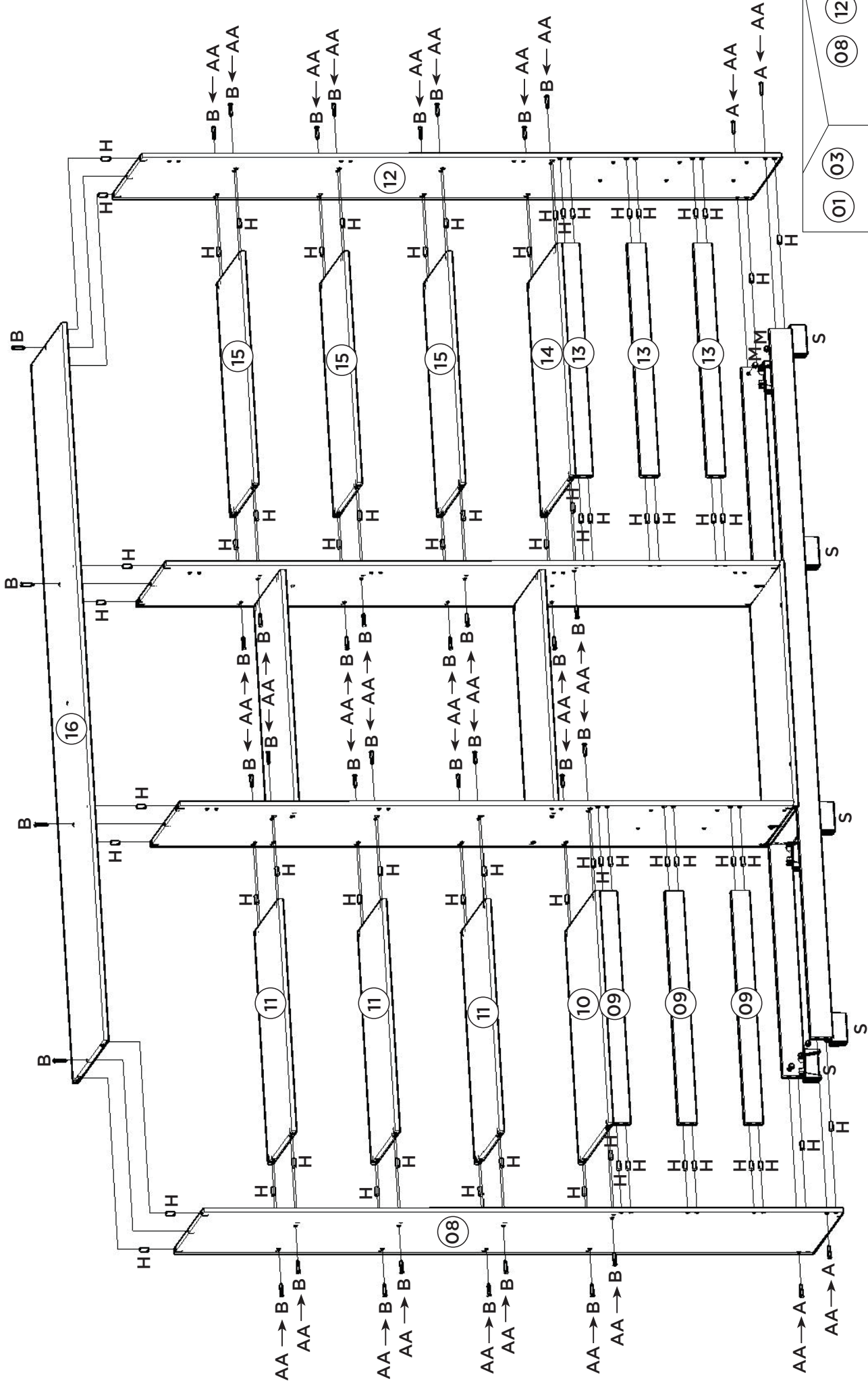

Fix the nails 100mm apart from one another.

Fijar las uñas a 100 mm distancia uno de otro.

Fixar os pregos a 100mm de distância de um para outro.

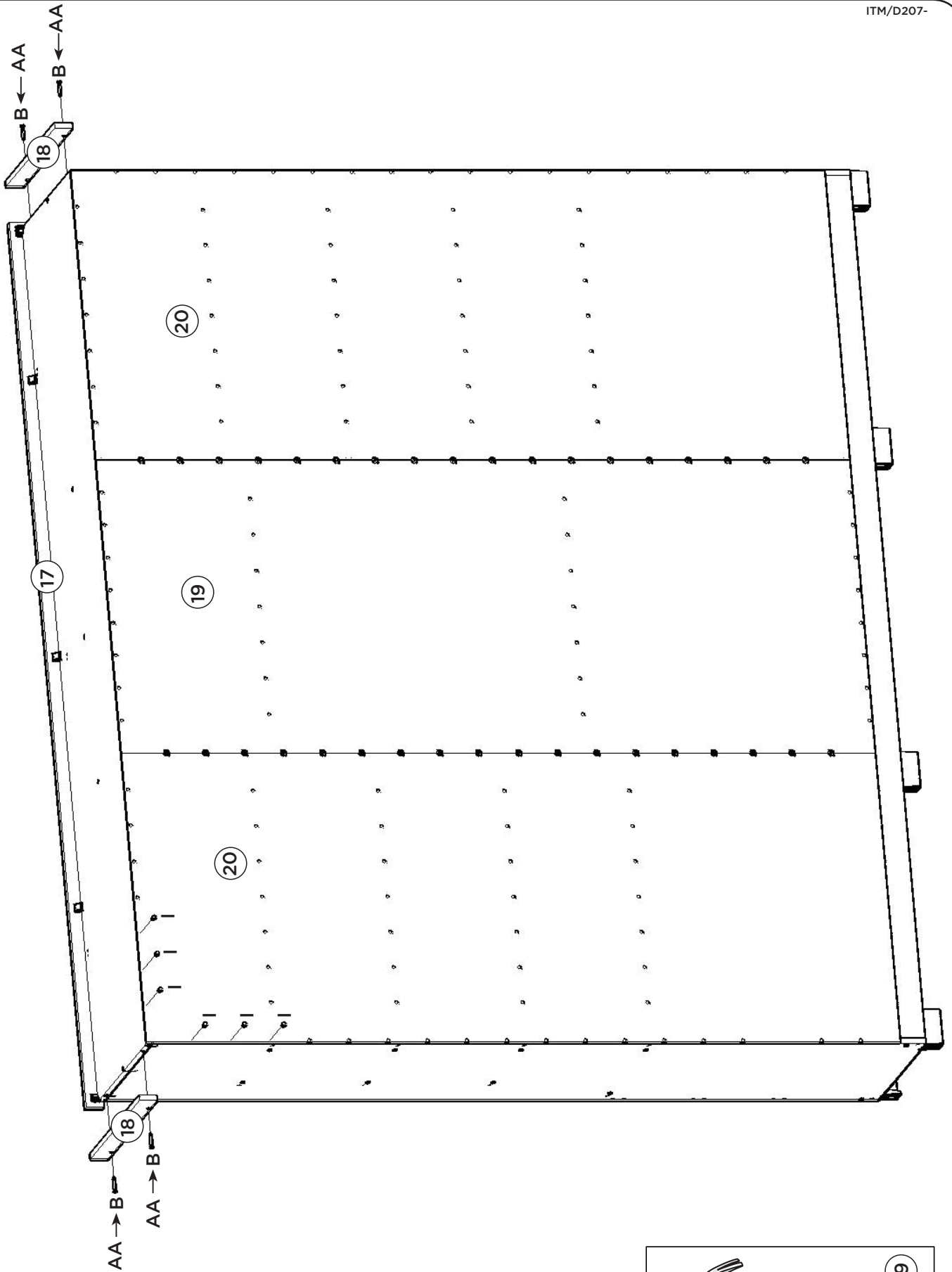
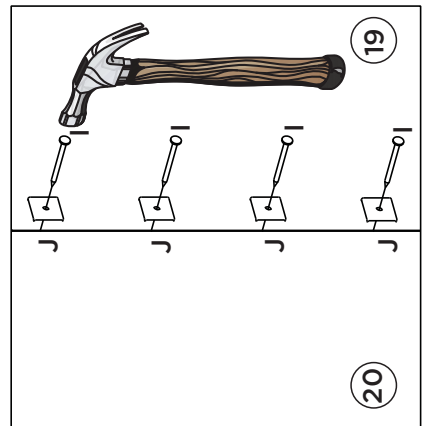
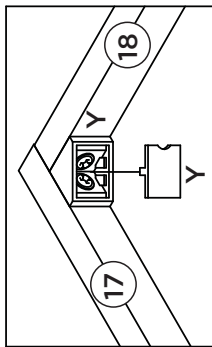
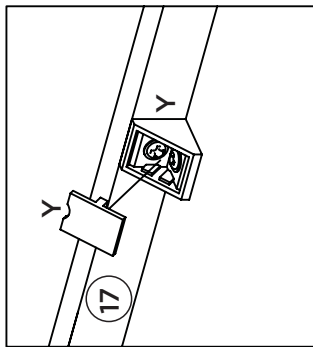
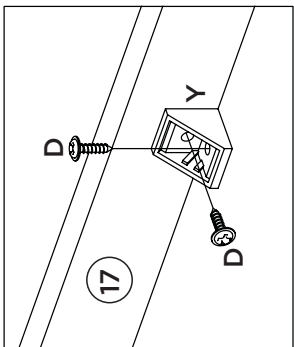

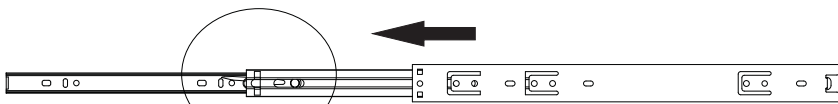
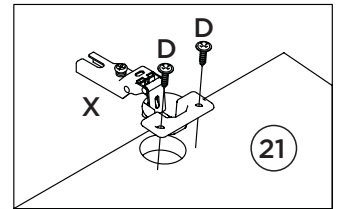
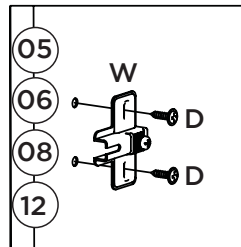
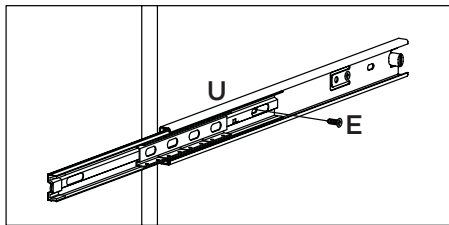
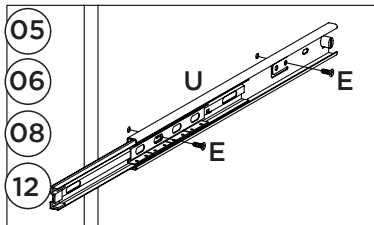
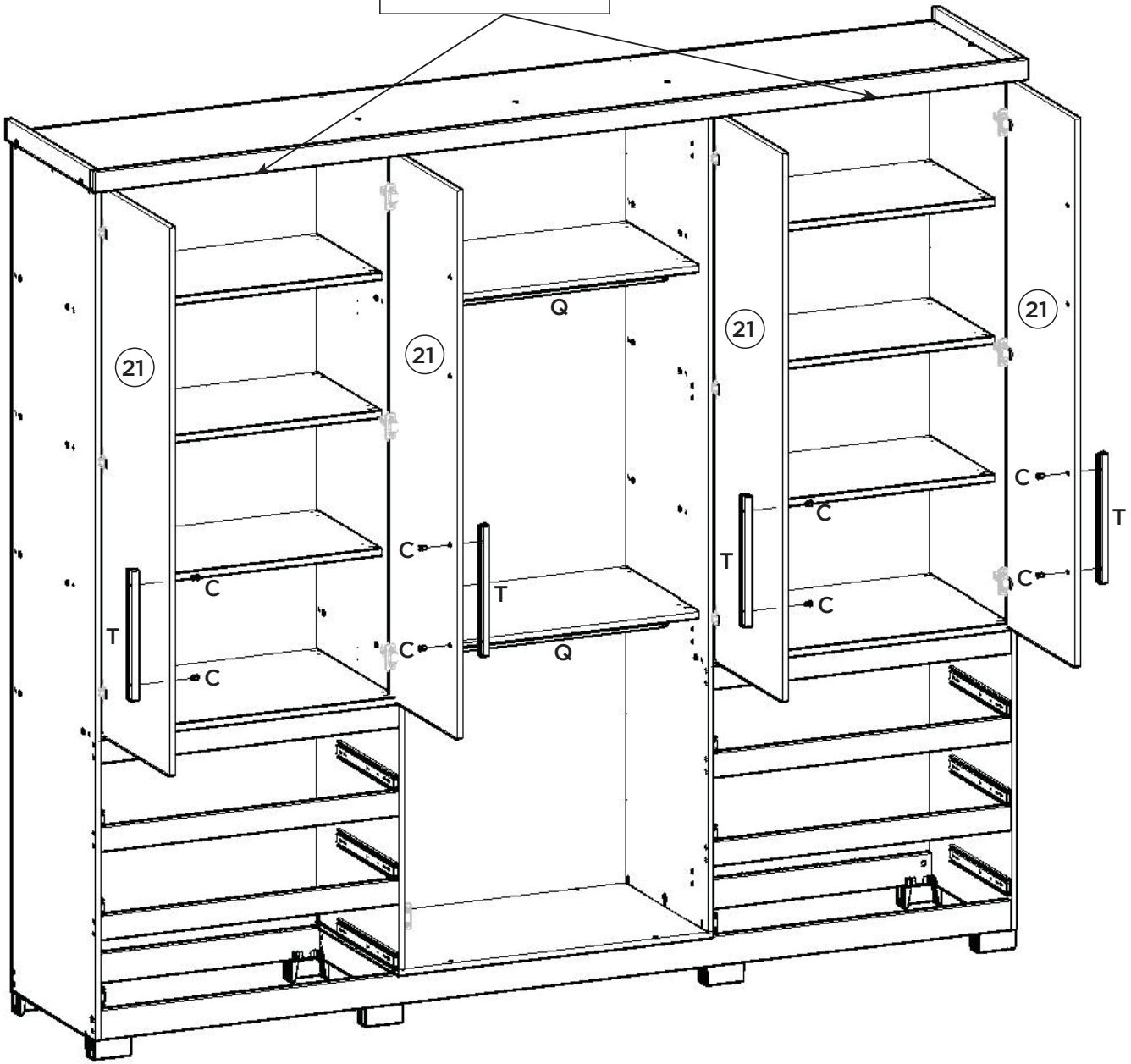
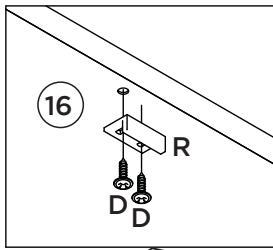

Para a desmontagem da corredeira siga a instrução ao lado.

Para el desmontaje seguimiento de diapositivas la instrucción siguiente a.

For the dismount of the sliding onem follows the instruction aside.

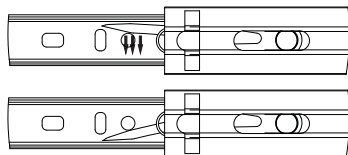

Fixar as corredeiras nessas furações
Fijar las diapositivas de estos agujeros
Fix slides in these drillings

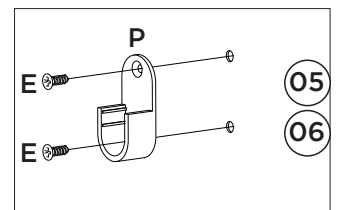
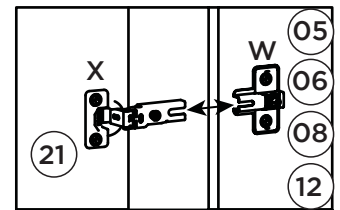

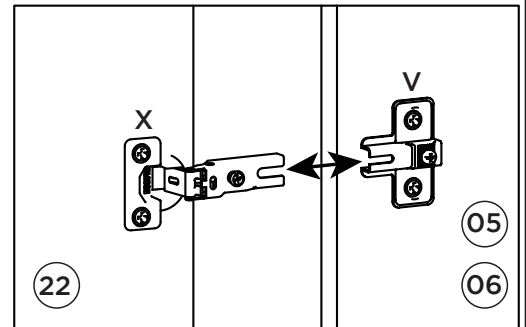
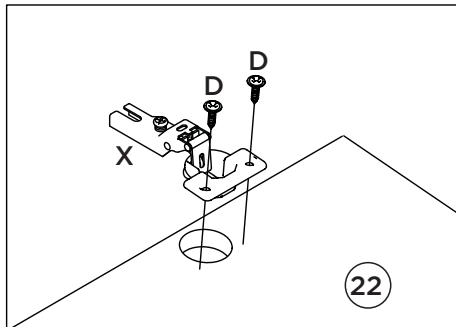
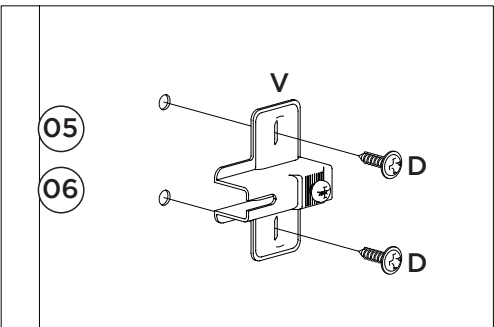
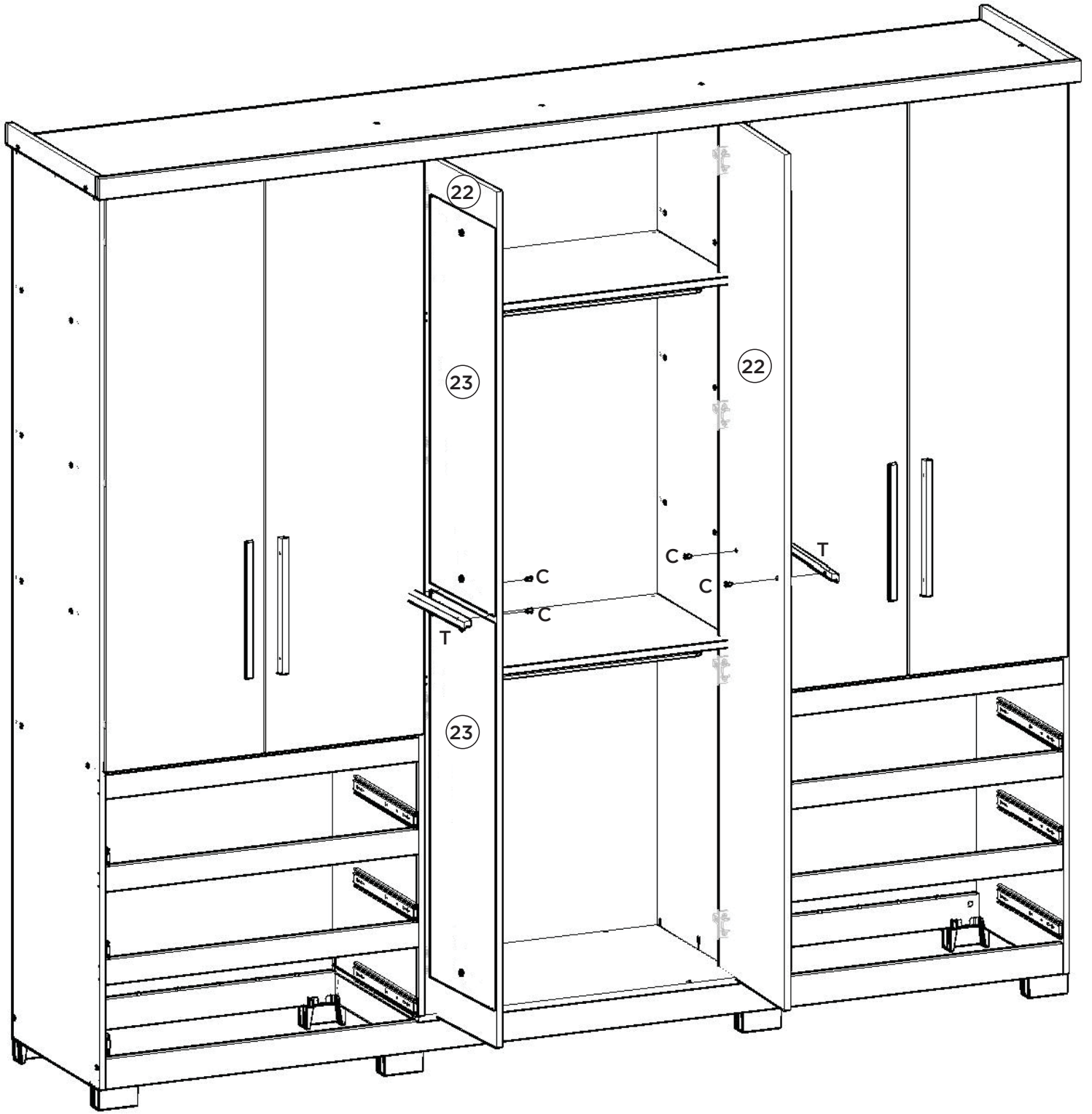

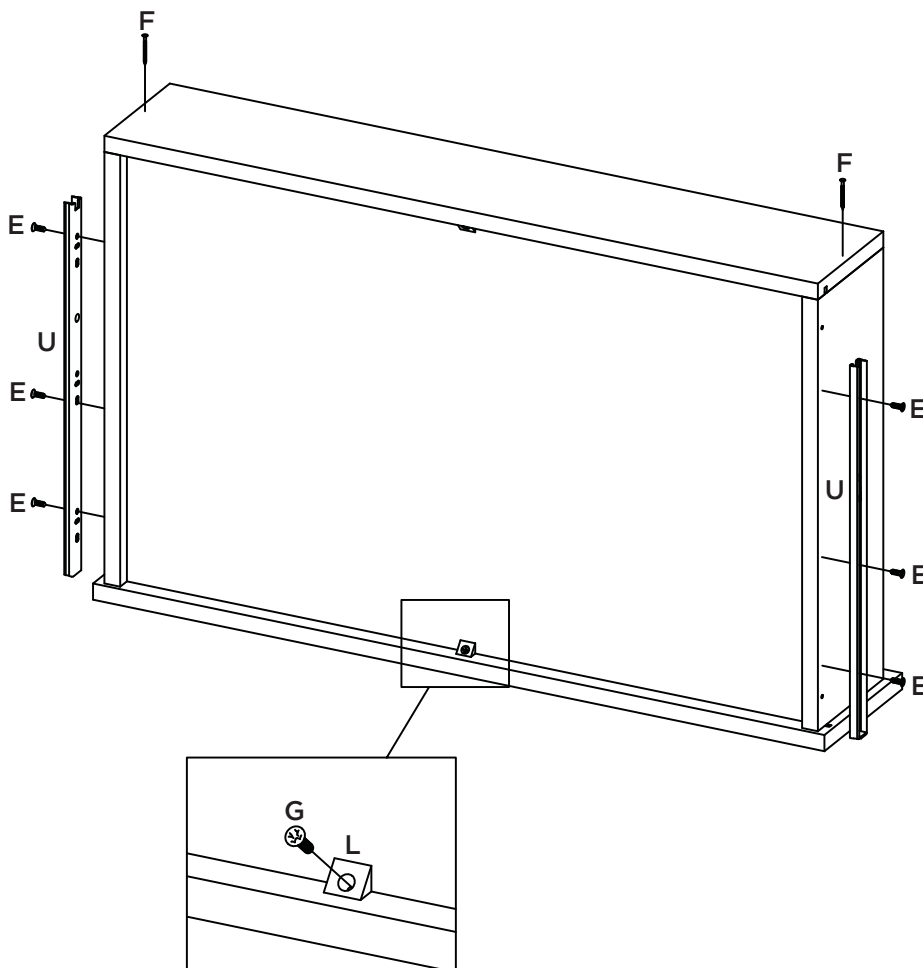
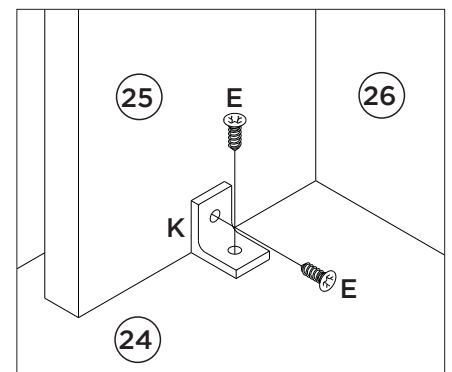
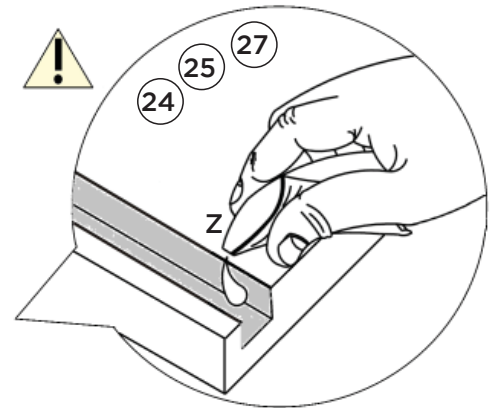
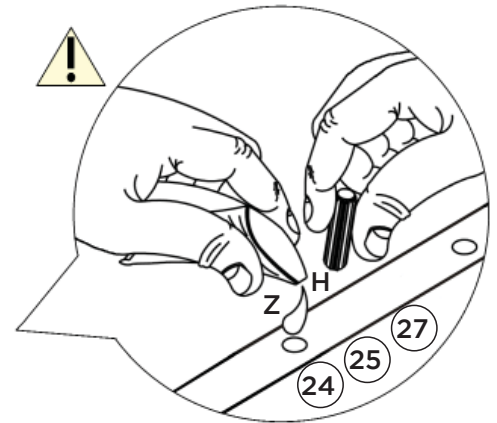
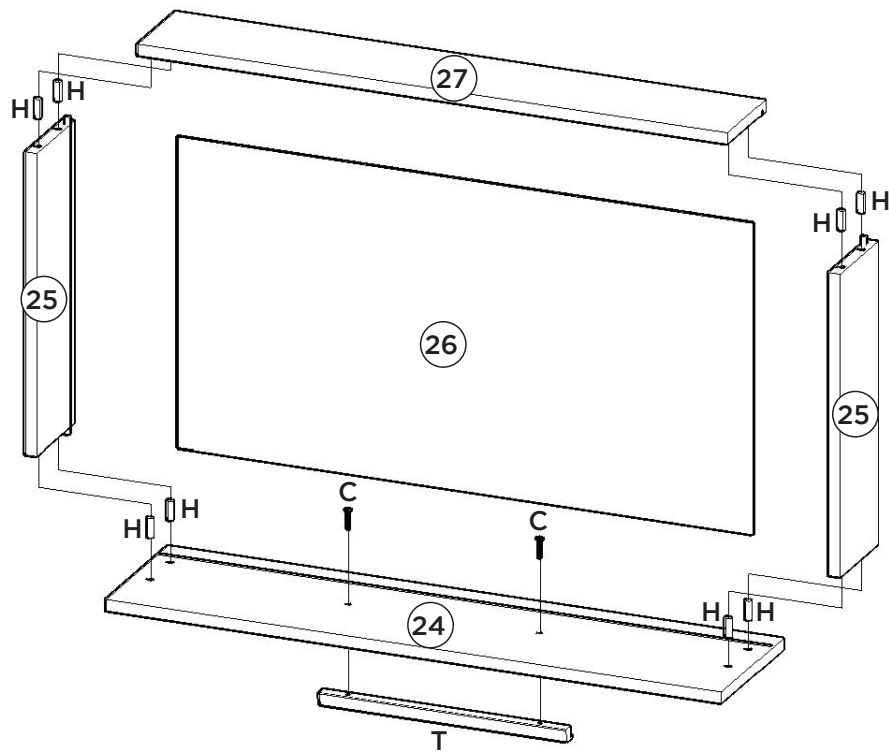











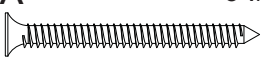
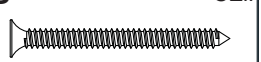

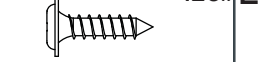





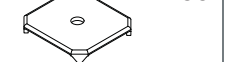









A correia (U) deverá ser alinhada com a parte de baixo do lado de gaveta (25).

la diapositiva (U) debe estar alineado con la parte inferior del cajón (25).

The slide (U) should be aligned with the underside of the drawer side (25).

Item	Caixa Caja Box	Qtd Ctd Qty	Descrição Descripción Description	Medidas (mm) Dimensions (mm) Size (measurements) (mm)
01	2/5	01	Rodapé Frontal Rodapié Frontal Front baseboard	2484x73x15
02	1/5	02	Travessa do rodapé Carril pie Baseboard crosspiece	464x73x15
03	2/5	01	Rodapé Traseiro Rodapié trasero Rear baseboard	2484x73x15
04	2/5	01	Base Base Base	858x500x15
05	1/5	01	Divisão esquerda División de la izquierda Left Division	2112x500x15
06	1/5	01	Divisão direita División derecha Right Division	2112x500x15
07	3/5	02	Prateleira Maior Central Estantería Mayor Central Central Greater shelf	828x450x15
08	1/5	01	Lateral esquerda Lateral izquierda Left side	2200x500x15
09=13	2/5 e 5/5	03	Travessa Frontal Gaveta Travesaño Frontal de la Cajón Drawer Front Tray	813x60x15
10=14	2/5	01	Tampo das Gavetas Superfície de cajones Surface of drawers	813x500x15
11=15	2/5	03	Prateleira Estante Shelf	813x400x15
12	1/5	01	Lateral direita Lateral derecha Right side	2200x500x15
13=09	5/5	03	Travessa Frontal Gaveta Travesaño Frontal de la Cajón Drawer Front Tray	813x60x15
14=10	2/5	01	Tampo das Gavetas Superfície de cajones Surface of drawers	813x500x15
15=11	3/5	03	Prateleira Estante Shelf	813x400x15
16	2/5	01	Tampo Tapa Top	2514x520x15
17	2/5	01	Moldura Frontal Marco frontal Front frame	2546x50x15
18	2/5	02	Moldura Lateral Marco lateral Lateral Frame	520x50x15
19	5/5	01	Fundo Fondo Bottom	2142x845x3
20	5/5	02	Fundo Lateral Fondo Lateral Lateral Background	2142x829x3
21	5/5	04	Porta Lateral Puerta lateral Side door	1412x409x15
22	4/5	02	Porta Puerta Door	2104x409x15
23	4/5	04	Espelho Espejo Mirror	950x330x3
24	5/5	06	Frente de gaveta Frente de cajón Front of drawer	823x200x15
25	3/5	12	Lado de gaveta Lado del cajón Side of drawer	400x122x15
26	2/5	06	Fundo de gaveta Fondo del cajón Drawer bottom	769x411x3
27	3/5	06	Ripa de trás Malla detrás Rear lath	788x122x15

Ferragens | Herrajes | Hardware

A 04x  Parafuso 4,5x50mm CHT. Tornillo 4,5x50mm CHT. Screw 4,5x50mm CHT.	B 52x  Parafuso 3,5x40mm CHT. Tornillo 3,5x40mm CHT. Screw 3,5x40mm CHT.	C 24x  Parafuso 3,5x25mm FLA. Tornillo 3,5x25mm FLA. Screw 3,5x25mm FLA.	D 126x  Parafuso 3,5x14mm FLA. Tornillo 3,5x14mm FLA. Screw 3,5x14mm FLA.	E 104x  Parafuso 3,5x12mm CHT. Tornillo 3,5x12mm CHT. Screw 3,5x12mm CHT.
F 12x  Parafuso 3,0x30mm CHT. Tornillo 3,0x30mm CHT. Screw 3,0x30mm CHT.	G 12x  Parafuso 3,0x16mm FLA. Tornillo 3,0x16mm FLA. Screw 3,0x16mm FLA.	H 136x  Cavilha 8x25mm Cinta 8x25mm Dowel 8x25mm	I 206x  Prego 10x10mm Clavo 10x10mm Nail 10x10mm	J 36x  Fixador de fundos Fijador de fondos Bottom fixer
K 16x  Cantoneira plástica Cantonera plástica Plastic angle brackets	L 12x  Cantoneira suporte triangular Cantonera soporte triangular Triangle support angle	M 04x  Porca cilíndrica Tuerca cilíndrica Cylindrical nut	N 02x  Tambor minifix Tambor minifix Minifix drum	O 02x  Parafuso minifix Tornillo minifix Minifix bolt
P 06x  Suporte cabideiro Soporte de percha Coat hanger support	Q 02x  Cabideiro Alum. 820mm Alu 820mm percha Alu coat hanger 820mm	R 02x  Batente 15x25mm Parada 15x25mm 15x25mm stop	S 08x  Pé "U" 50x40x100mm Pie "U" 50x40x100mm 50x40x100mm "U" feet	T 12x  Perfil Puxador Revestido MDF 330mm Perfil Tirador Revestido MDF 330mm Profile MDF 330mm Coated Handle
U 06x  Corrediça telescópica Corredera telescópica Telescopic slide	V 08x  Calço metal 12mm Calzado metálico 12mm 12 mm metal shim	W 12x  Calço metal 5mm Calzado metálico 5mm 5 mm metal shim	X 20x  Dobradiça metal 26mm Bisagra de metal 26mm 26 mm metal hinge	Y 05x  Conector de montagem Conector de montaje Mounting connector
Z 03x  Sachê de cola Bolsa de pegamento Glue bag	AA 52x  Adesivo tapa parafuso 10mm Adhesivo tapón de tornillo 10mm Bolt cover adhesive 10mm	AB 02x  Giz de correção Tiza de corrección Chalk of correction	AC 01x  Etiqueta resinada Henn Etiqueta resinada Henn Henn resin label	