



**MANUAL DE MONTAGEM
ASSEMBLY INSTRUCTIONS
INSTRUCCIONES DE MONTAJE**

COD BR: BE 66-160

Sumário Summary Resumen

Introdução Introduction Introducción	3
Antes de começar Before starting Antes de comenzar	4
Evite acidentes Avoid accidents Evitar accidentes	4
Dimensões e ferramentas Dimensions and tools Dimensiones y herramientas	5
Identificação das peças Identifying parts Identificación de las piezas alguma decoração na par	6
Acessórios incluídos na caixa Hardware included in box Accesorios incluidos en la caja	7
Montagem do móvel Furniture assembly Montaje del mueble	8

Introdução Introduction Introducción

Leia atentamente este manual e siga os passos indicados para uma perfeita montagem.
Read this manual and follow the steps for the perfect fit.
Lea este manual y siga los pasos para el ajuste perfecto.

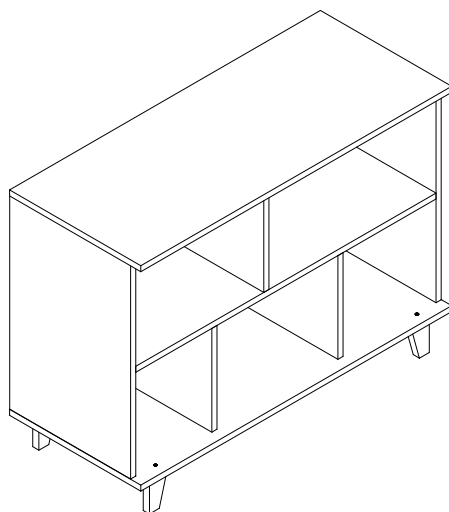

Antes de começar Before starting Antes de comenzar

Antes de começar a montagem prepare o ambiente, deixando-o completamente limpo e com bom espaço para iniciar o trabalho.

Prepare the room before starting the assembly, leaving it completely clean and the area in good condition to start the work.

Antes de comenzar el montaje preparar el ambiente, dejándolo completamente limpio y con bueno espacio para comenzar el trabajo.

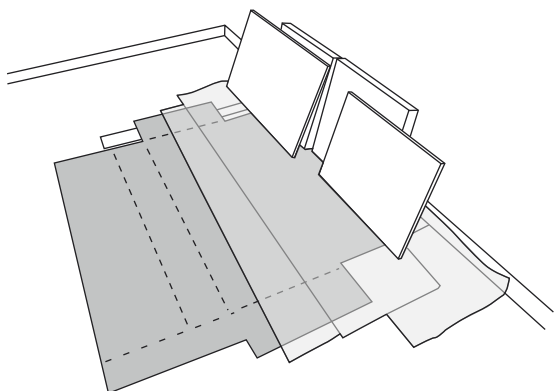

Utilize o papelão da própria embalagem para separar e apoiar as peças retiradas das caixas.

Use the cardboard of the packaging to separate and support the parts removed from the boxes.

Utilice el cartón de la embalaje para separar y apoyar las piezas desmontadas de las cajas.



Forre a área de montagem com um cobertor ou tapete. Assim, você evita avarias nas peças durante o processo de montagem.

Cover the assembly area with a blanket or carpet to avoid damaging the parts during the assembly process.

Cubrir la zona de ensamble con una manta o alfombra. De este modo, se evitan daños en las piezas durante el proceso de montaje.



Evite acidentes Avoid accidents Prevenir accidentes



Não escale ou se apoie no móvel.

Do not climb or lean on the furniture.

No se suba ni se apoye en el mueble.

Dimensões e ferramentas
Dimensions and tools
Dimensiones y herramientas

Dimensões:

L: 900 A: 655 P: 380 mm

Dimensions:

W: 35.43 H: 25.79 D: 14.96 inches

Dimensiones:

L: 900 A: 655 P: 380 mm

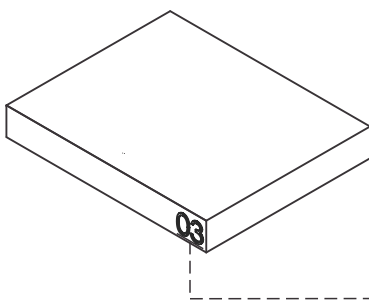
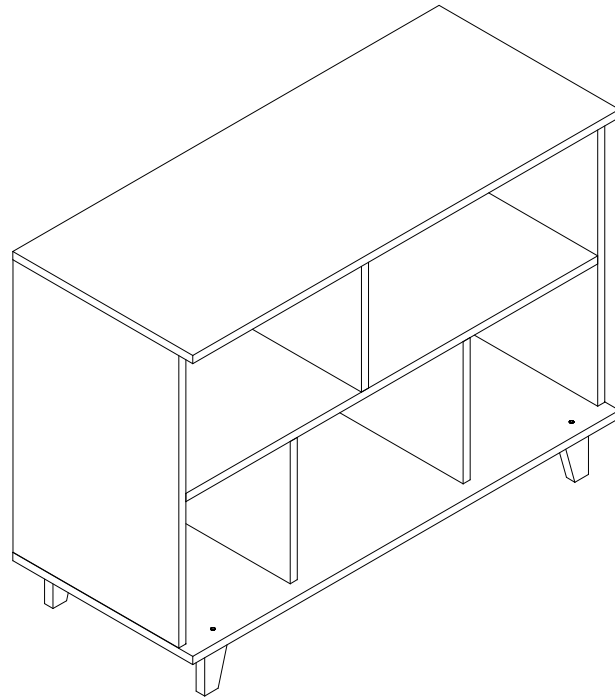

UTILIZE ALCOOL PARA REMOVER O NUMERO DAS PEÇAS
USE ALCOHOL TO REMOVE PART NUMBERS
UTILICE ALCOHOL PARA ELIMINAR EL NUMERO DE LAS PIEZAS

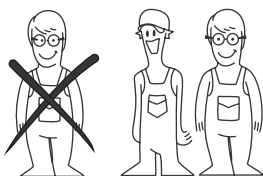

Para facilitar a montagem, utilize uma parafusadeira elétrica.
To improve assembly, use an electronic screwdriver.
Para facilitar el armado, utilice un destornillador eléctrico.

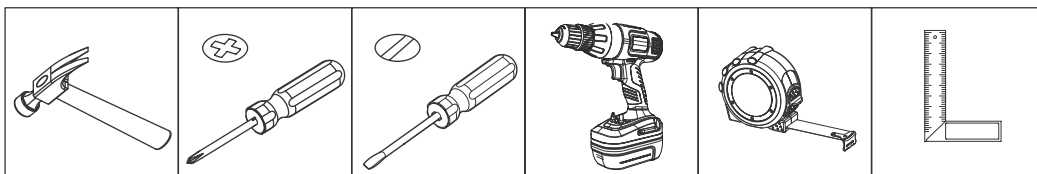

COD BR: BE 66-160

PEÇA	DESCRIÇÃO	QUANT.
001	BASE	1
002	TAMPO	1
003	LATERAL ESQUERDA	1
004	PRATELEIRA	1
005	DIVISÓRIA	3
006	COSTA MENOR	1
007	COSTA MAIOR	1
008	LATERAL DIREITA	1
009	PÉS	4

PART	DESCRIPTION	QTY
001	BASE	1
002	TOP	1
003	LEFT SIDE	1
004	SHELF	1
005	PARTITION	3
006	LOWER BACK	1
007	LONGER BACK	1
008	RIGHT SIDE	1
009	FEET	4

PIEZA	DESCRIPCIÓN	CANTIDAD
001	BASE	1
002	TAPA	1
003	LATERAL IZQUIERDA	1
004	REPISA	1
005	PARTICION	3
006	REVÉS MENOR	1
007	REVÉS MAYOR	1
008	LATERAL DERECHA	1
009	PIES	4

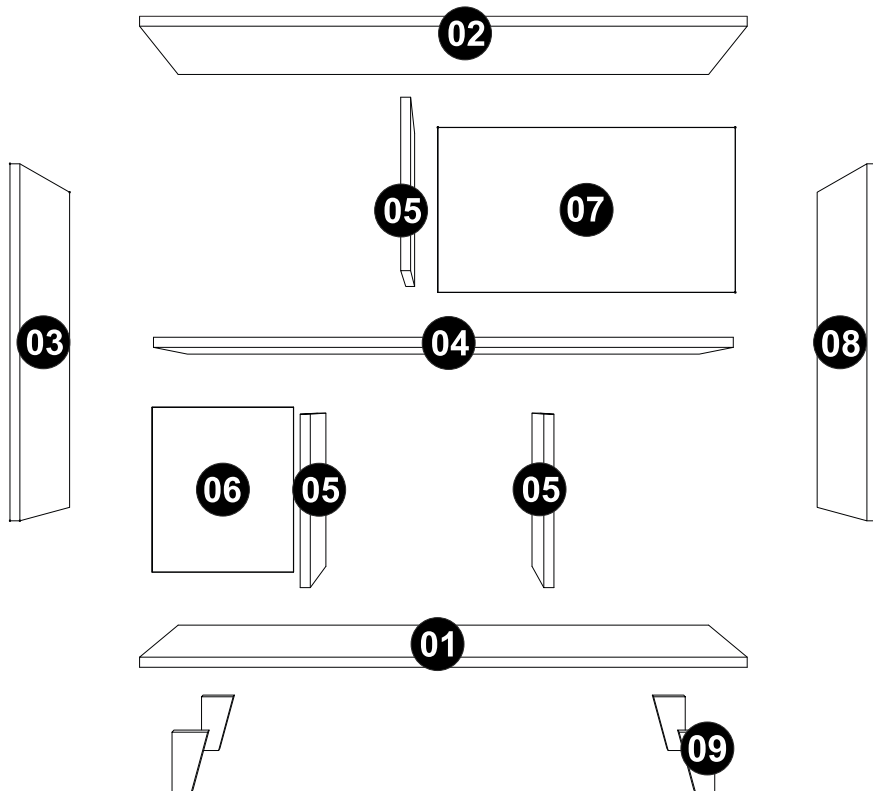

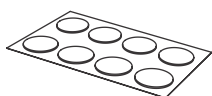

TAPA FUROS x 18
STICKER x 18
TAPAS PLÁSTICAS x 18

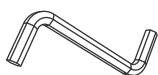

EF 000741 x 1



EF 000241 x 4
8x20



EF 000033 x 24
8x30



EF 000745 x 4
5X40



EF 000132 x 10
4X50 CC



EF 000094 X 14



GIZ x 01
CHALK x 01
TIZA x 01

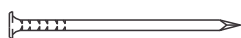

EF 000168 X 28
10x10C/C



EF 000216 X 14

Utilize para medir as ferragens.

Utilice para medir el herraje.

Use for measuring the hardware.

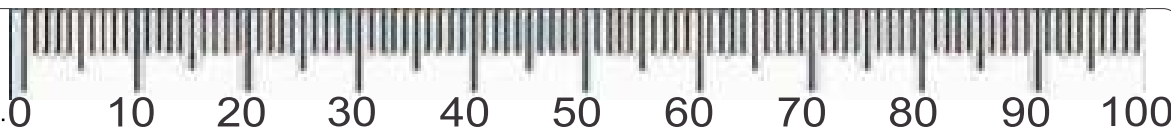

Garantia (exclusivo para o Brasil/exclusivo de Brasil/exclusive to Brazil):

A garantia dos produtos fabricados pela BRV Móveis, abrange eventuais defeitos-vícios de fabricação, no prazo estabelecido pelo código de Defesa do Consumidor, em seu artigo 26.II. o qual prevê a garantia de 90 (noventa) dias.

A = 12.3KG - 27.1LB

B = 8KG - 17.6LB

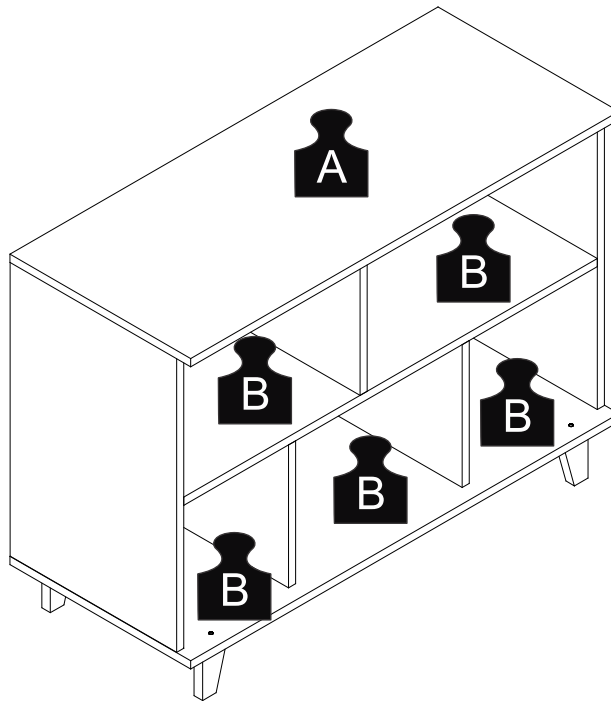

PASSO 1 / STEP 1 / PASO 1

Fixe a ferragem EF 000094 nas pré-furações indicadas nas peças 01, 02, 03 e 08.

Fix hardware EF 000094 at pre-drilled holes indicated at pieces 01, 02, 03 and 08.

Fije el herraje EF000094 el los huecos ya marcados en las piezas 01, 02, 03 y 08.

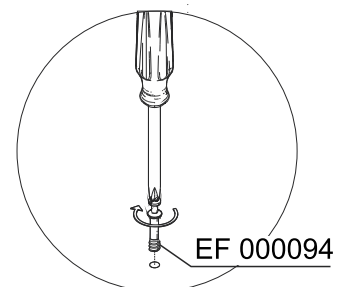
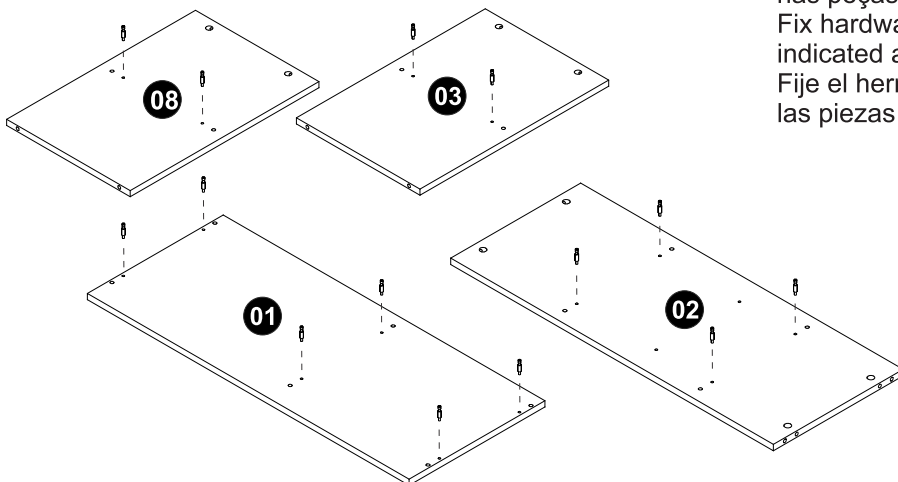

PASSO 2 / STEP 2 / PASO 2

Insira a ferragem EF 000033 nas peças 03, 05, 07 e 08.
Insert hardware EF 000033 in pieces 03, 05, 07 and 08.
Añade el herraje EF 000033 en las piezas 03, 05, 07 y 08.

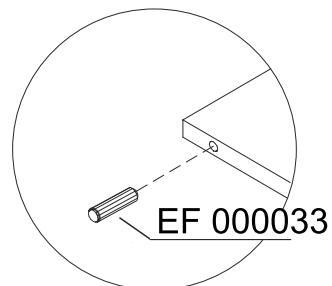
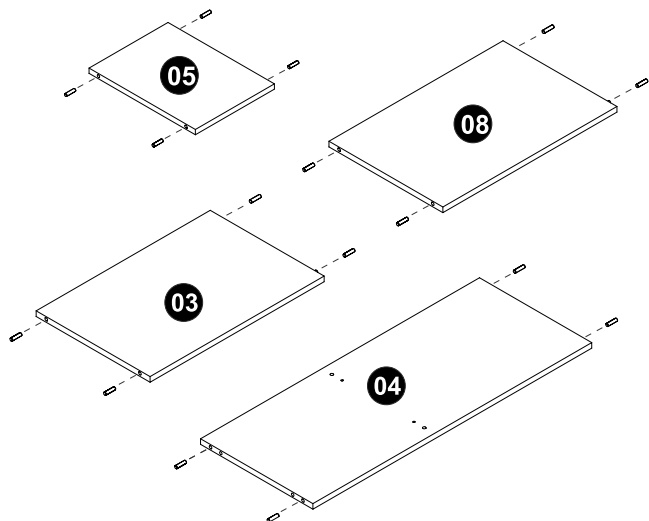

PASSO 3 / STEP 3 / PASO 3

Insira a ferragem EF 000241 nas peças 09.
Insert hardware EF 000241 in pieces 09.
Añade el herraje EF 000241 en las piezas 09.

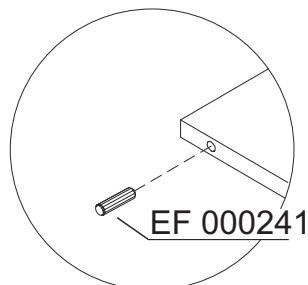
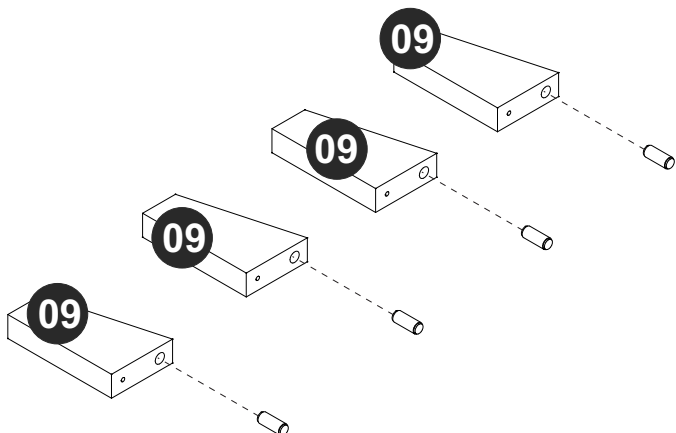

PASSO 4 / STEP 4 / PASO 4

Fixe as peças 09 à peça 01 utilizando a ferragem EF 000745 e EF 000741.
Fix pieces 09 to piece 01 using hardware EF 000745 and EF 000741.
Junte las piezas 09 a la pieza 01 utilizando los herrajes EF 000745 y EF 000741.

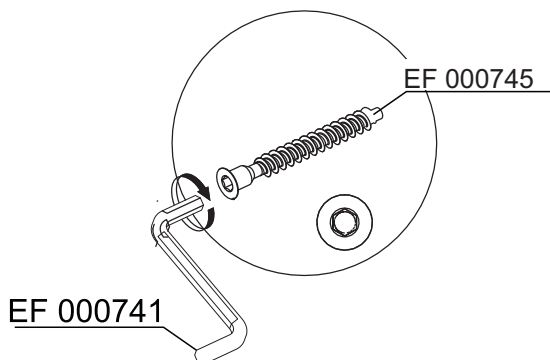
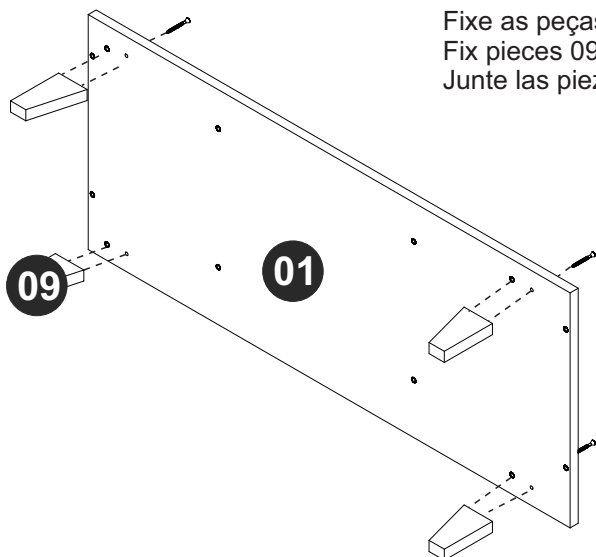

PASSO 5 / STEP 5 / PASO 5

Usando o parafuso EF 000132, fixe a peça 04 na peça 05.
Using hardware EF 000132 fix piece 04 at piece 05.
Utilizando el tornillo EF000132, fije la pieza 01 en la pieza 05.

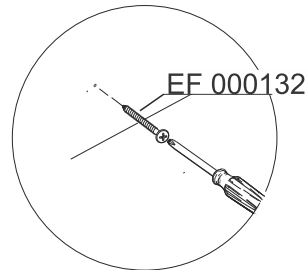
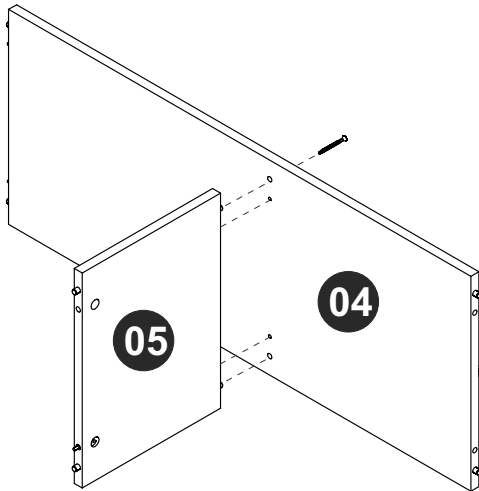

PASSO 6 / STEP 6 / PASO 6

Conecte as peças 05 à parte montada no passo anterior, insira a ferragem EF 000216 e gire para apertar.
Connect pieces 05 to the part assembled in the previous step, insert hardware EF 000216 and turn to tighten.
Junte las piezas 05 a la parte armada en el paso anterior, añade el herraje EF 000216 y gire para apretar.

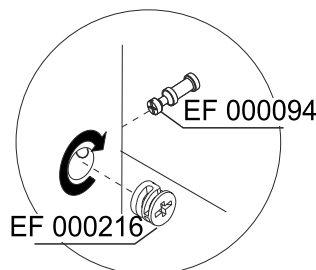
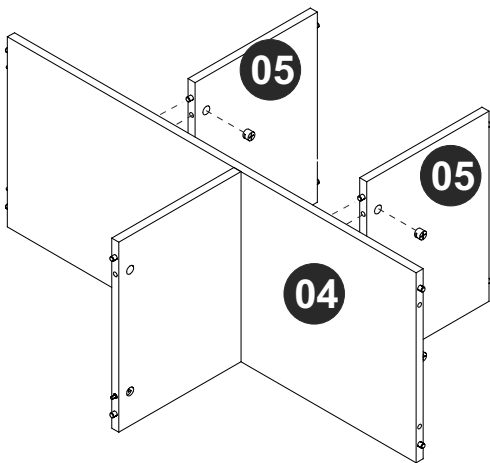

PASSO 7 / STEP 7 / PASO 7

Conecte as peças 03 e 08 à parte montada no passo anterior, insira a ferragem EF 000216 e gire para apertar.
Connect pieces 03 and 08 to the part assembled in the previous step, insert hardware EF 000216 and turn to tighten.
Junte las piezas 03 y 08 a la parte armada en el paso anterior, añade el herraje EF 000216 y gire para apretar.

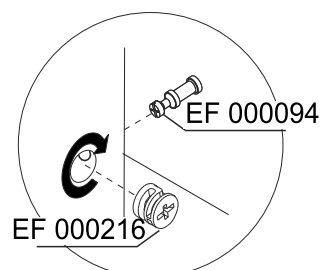
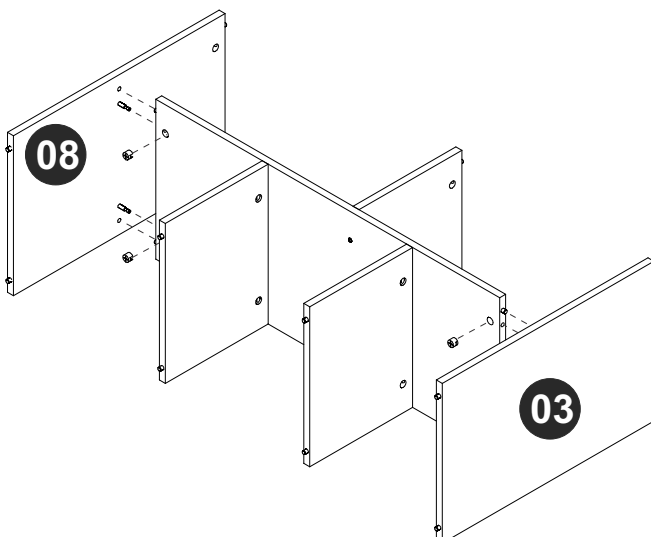

PASSO 8 / STEP 8 / PASO 8

Fixe a peça 01 utilizando a ferragem EF 000132.
Attach piece 01 using hardware EF 000132.
Fije la pieza 01 utilizando el herraje EF 000132.

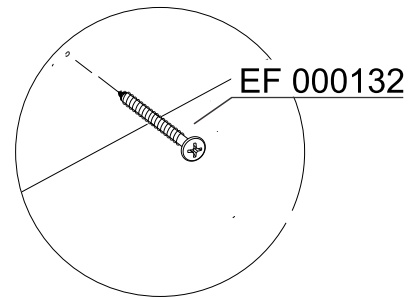
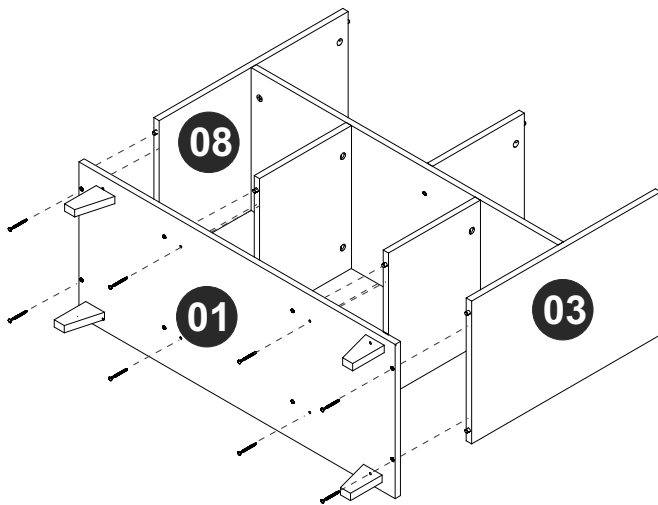

PASSO 9 / STEP 9 / PASO 9

Conecte a peça 02 à parte montada no passo anterior, insira a ferragem EF 000216 e gire para apertar.
Connect piece 01 to the part assembled in the previous step, insert hardware EF 000216 and turn to tighten.
Junte la pieza 01 a la parte armada en el paso anterior, añade el herraje EF 000216 y gire para apretar.

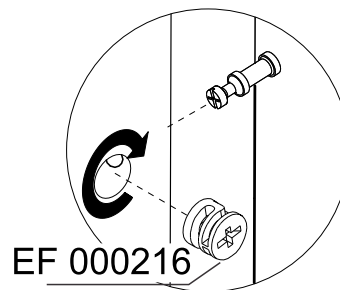
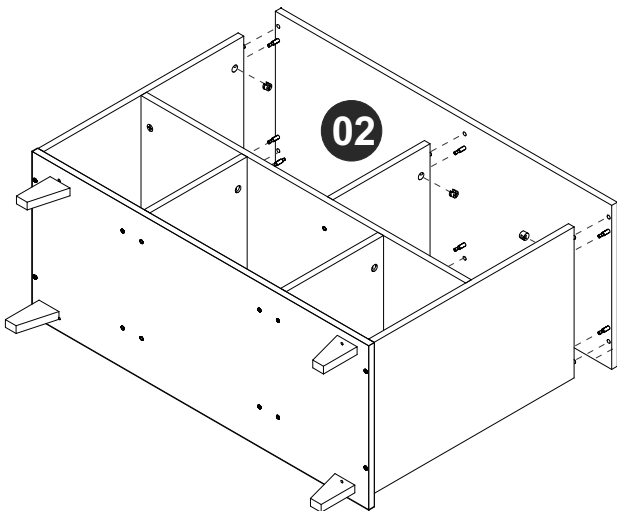

PASSO 10 / STEP 10 / PASO 10

Fixe as peças 06 e 07 à parte montada no passo anterior a utilizando ferragem EF 000168.
Attach pieces 06 and 07 to the part assembled in the previous step using hardware EF 000168.
Fije las piezas 06 y 07 a la parte armada en el paso anterior utilizando el herraje EF 000168.

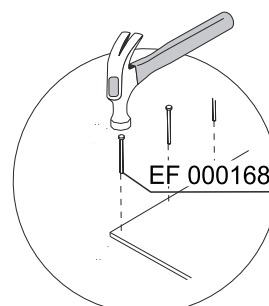
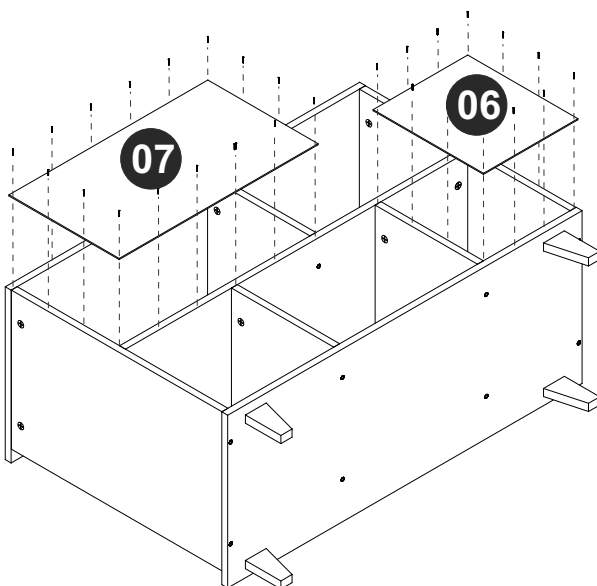

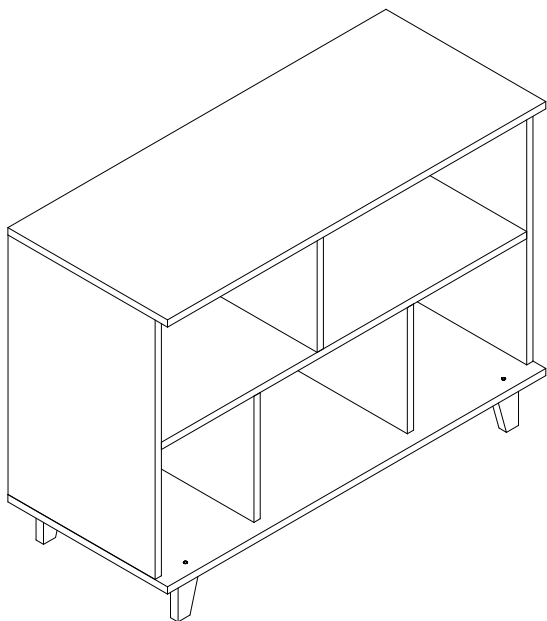

PASSO 11 / STEP 11 / PASO 11

Utilize o tapa furos para cobrir os parafusos aparentes.
Use the sticker to cover the apparent screws.
Utilice los tapa huecos para cubrir los tornillos aparentes.

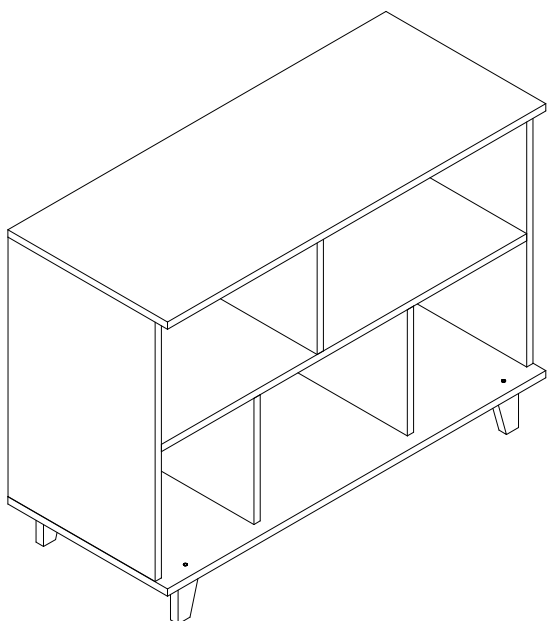
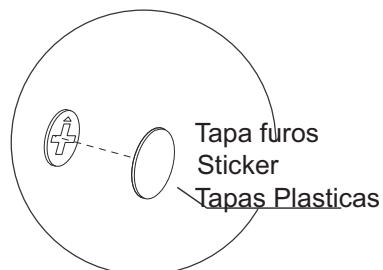

PASSO 11 / STEP 11 / PASO 11

Use o giz para dar o acabamento final ao produto.
Use the chalk to give the final finish on the product.
Utilice la tiza para dar el acabado final al producto.

