

# RP1032- ROUPEIRO

Manual de Montagem  
 Assembly Instructions  
 Instrucción de Montaje

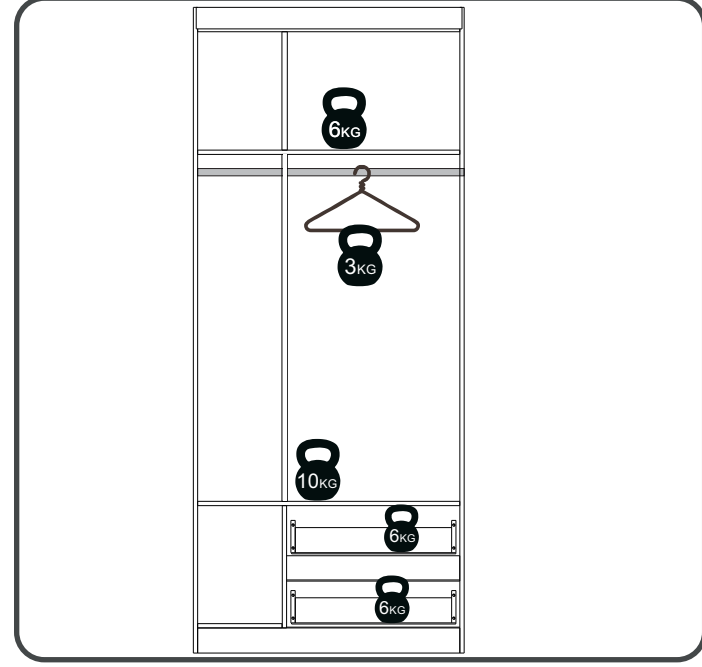
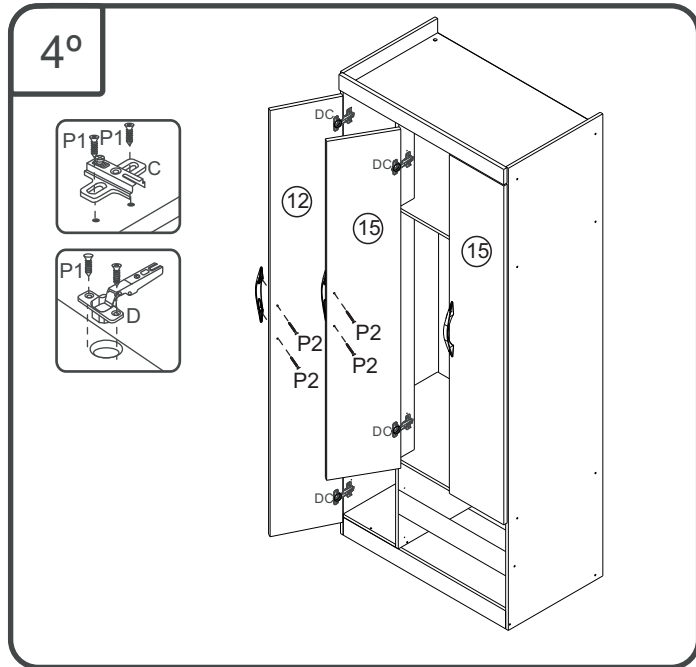
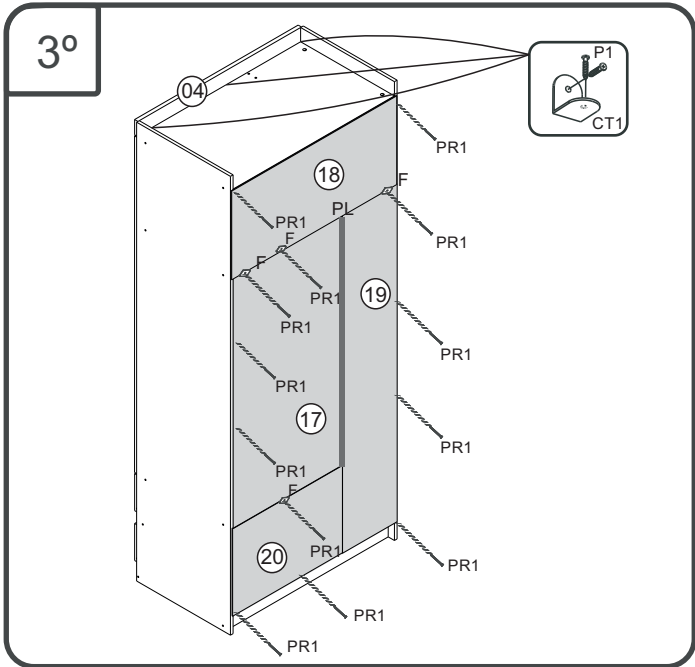
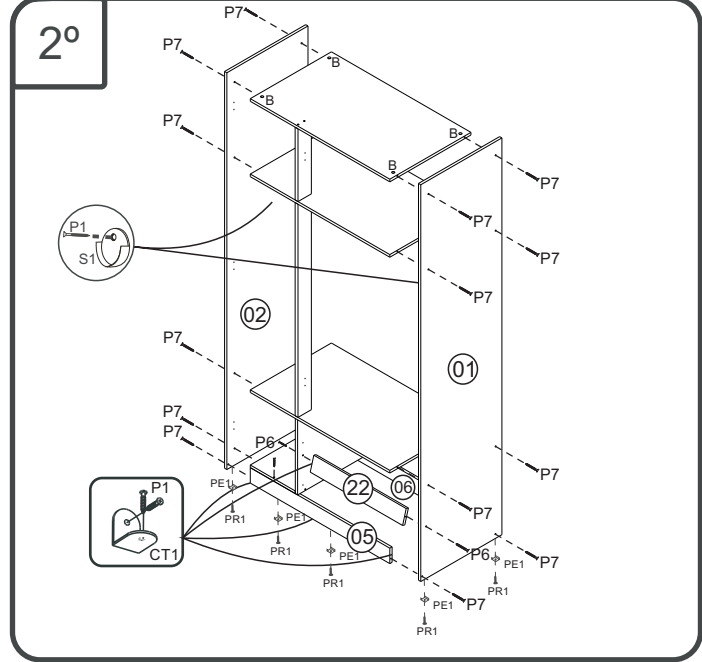
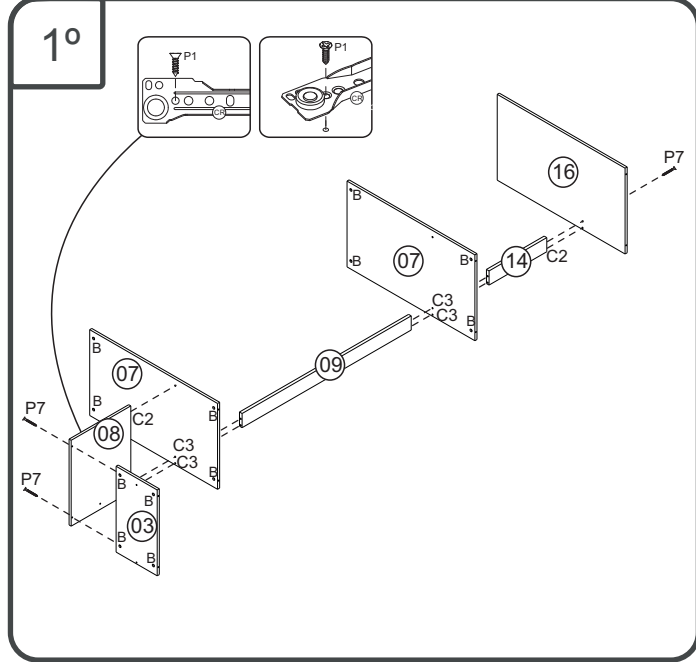
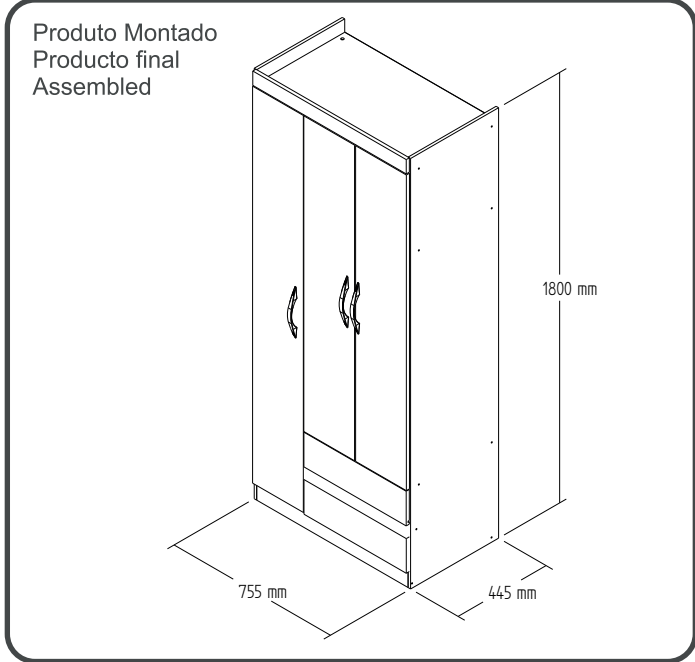

# RP1032- ROUPEIRO

## Manual de Montagem Assembly Instructions Instrucción de Montaje

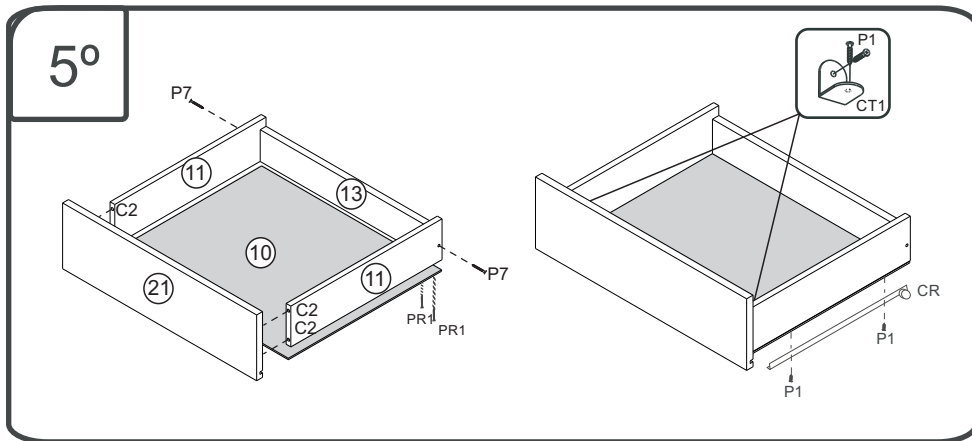

### Relação de Peças/ Relación de Piezas/Parts List

Nº	CÓDIGO/CODE	DESCRIÇÃO/DESCRIPCIÓN/DESCRIPTION	QTD/CANT	VOL.
1	0520011	LATERAL/LATERAL/SIDE 1800x425x12 MM P	1,00	1
2	0520012	LATERAL/LATERAL/SIDE 1800x425x12 MM P	1,00	1
3	0520013	BASE 425X235X12 MM P	1,00	1
4	0520014	RODAFORRO 741X60X15 MM P	1,00	1
5	0520016	RODAPÉ/ZÓCALO/BASEBOARD 731X70X12 MM P	1,00	1
6	0520020	RODAPÉ/ZÓCALO/BASEBOARD 731X70X12 MM P	1,00	1
7	0520021	BASE 731X425X12 MM P	2,00	1
8	0520022	DIVISORIA/DIVIDER 425X341X12 MM P	1,00	1
9	0520018	PILASTRA/PILASTER 967X70X15 MM P	1,00	1
10	0520033	FUNDO DE GAVETA/FONDO CAJÓN/DRAWER BOTTOM 458X390X3,2 MM P	2,00	1
11	0520027	LATERAL GAVETA/LATERAL CAJÓN/DRAWER SIDE 385X90X12 MM P	4,00	1
12	0520017	PORTA/PUERTA/DOOR 1660X245X15 MM P	1,00	1
13	0520028	BATENTE/REVÉS CAJON/DRAWER BACK 436X70X15 MM P	2,00	1
14	0520025	PILASTRA/PILASTER 330X70X15 MM P	1,00	1
15	0520019	PORTA/PUERTA/DOOR 1320X245X15 MM P	2,00	1
16	0520024	BASE 731X425X12 MM P	1,00	1
17	0520029	COSTA 980X499X2,8 MM P	1,00	1
18	0520030	COSTA/REVÉS/BACK 751X348X2,8 MM P	1,00	1
19	0520031	COSTA/REVÉS/BACK 1325X251X2,8 MM P	1,00	1
20	0520122	COSTA/REVÉS/BACK 499X344X2,8 MM P	1,00	1
21	0520026	FRENTE DE GAVETA/FRENTE CAJÓN DRAWER FRONT 494X145X15 MM P	2,00	1
22	0520023	TRAVERSA/TRAVIESA/TRVERSE 484X70X12 MM P	1,00	1

### Ferragens/ Herrajes/ Hardware escala (1:1)

LEGENDA	DESCRIÇÃO/DESCRIPCIÓN/DESCRIPTION	CÓDIGO	QUANT.
P7	 PARAFUSO/TORNILLO/SCREW 4X45	07653	23
P1	 PARAFUSO/TORNILLO/SCREW 3,5X12	01328	80
PR1	 PREGO/CLAVO/NAIL 10X10	01330	80
C2	 CAVILHA/TARUGO/DOWEL 6X30 MM	01211	12
P2	 PARAFUSO/TORNILLO/SCREW 3,5X25	03130	06
C3	 CAVILHA/TARUGO/DOWEL 6X50 MM	01212	04
B	 BUCHA/BUJE/BUCHING	02734	18
P6	 PARAFUSO/TORNILLO/SCREW 4X35	07719	06

#### ATENÇÃO!!!! montadores e consumidores

\* Para limpar o móveis utilize somente um pano úmido (umedecido em água pura ou água com sabão neutro). Depois, passe um pano seco. Evite a umidade excessiva.  
\* Evite usar álcool, água sanitária, detergente e outros produtos químicos, mesmo diluídos em água. Não utilize produtos abrasivos de nenhuma espécie

#### ATENCIÓN!!!! montadores e consumidores

\* Para limpiar el mueble utilice solamente un paño húmedo (humedecido con agua limpia o con un jabón suave). A continuación, utilice un paño seco. Evite el exceso de humedad.  
\* Evite uso de alcohol, hipoclorido solución basada, detergente y otros productos químicos, mismo diluídos en agua. No utilice productos abrasivos de ningún tipo.

#### ATTENTION!!!! assemblers and consumers

\* To clean the furniture, use only a damp cloth (humidify it only in pure water or water and neutral soap). After, use a dry cloth. Avoid excessive humidity.  
\* Avoid using alcohol, bleach, detergent and other chemical products, even diluted in water. Do not use any kind of abrasive cleaning agents to clean the furniture.  
The use of such products may jeopardize the final characteristics of the furniture.

# RP1032- ROUPEIRO

## Ferragens/ Herrajes/ Hardware escala (N/A)

LEGENDA	DESCRIÇÃO/DESCRIPCIÓN/DESCRIPTION	CÓDIGO	QUANT.
CL	 COLA/PEGAMENTO/GLUE	01213	01
ET	 ETIQUETA LOGO DECIBAL/LABEL DECIBAL	01312	01
S1	 SUPORTE CABIDEIRO SOPORTE PERCHERO/SUPPORT TO HANGER SUPPORT	02033	02
CT1	 CANTONEIRA/PIEZA L/METAL SHEET 22X22MM	01270	13
CR	 CORREDICA/CORREDERA/METALIC SLIDE LARG350 MM	01225	02
DC	 DOBRADIÇA/BISAGRA/HINGE D=26mm C=5mm	01268	07
F	 FIXADOR COSTA/FIJADOR FONDO/FIXER COAST	01331	13
PX	 PUXADOR/PEGADOR/HANDLE	03161	03

PE1	 PÉ/PATA/FOOT	01367	06
CB	 CABIDEIRO/ROLIZO PERCHA/ROD FOR HANGERS 722 MM	07547	01
PL	 PERFIL/PROFILE/PERFIL 971 MM	09313	01

Ferramenta necessárias  
Necessary tools  
Herramientas necesarias



60 min.



1 montador  
1 ajustador  
1 fitter

[www.decibal.com.br](http://www.decibal.com.br)



Medida em mm

R1