

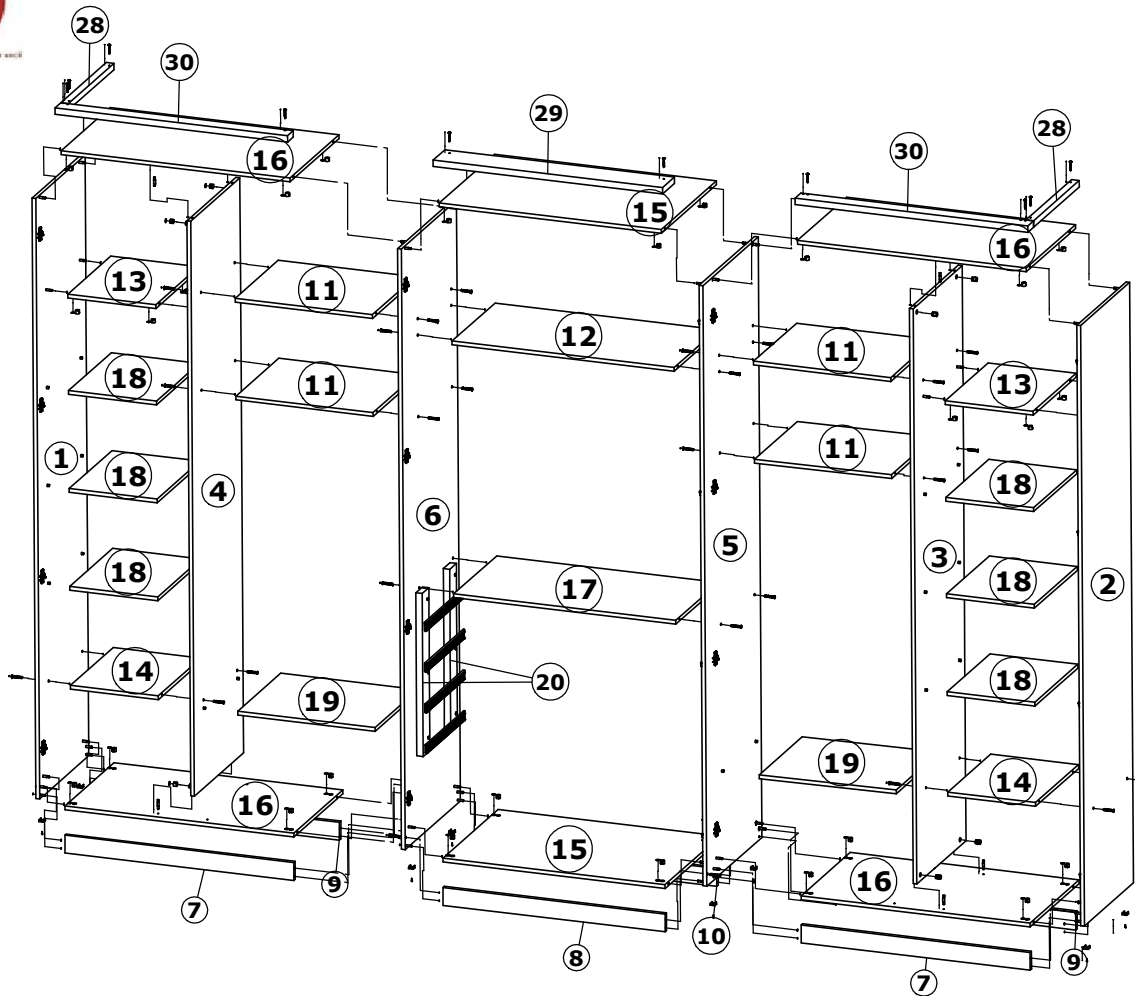

Roupeiro Unique_Requinte 6 Portas / Wardrobe Unique_Requinte 6 Doors / Ropero Unique_Requinte 6 Puertas



Roupeiro Unique

26 - Fevereiro - 2018

Peça Pieza	Cod.	Descrição	Description	Descripción	Qtde Qty Cant	Compr Length Largo	Larg. Widtht Ancho	Esp. Tickness Espessor
1	P13367	Lateral Esq.	Left Side Panel	Lateral Izquierda	1	2357	514	15
2	P13368	Lateral Dir.	Right Side Panel	Lateral Derecha	1	2357	514	15
3	P13336	Divisão Direita	Right Division	Division Derecha	1	2257	514	15
4	P13324	Divisão Esquerda	Left Division	Division Izquierda	1	2257	514	15
5	P13366	Divisão Central Direita	Central division right	División Central a la derecha	1	2357	578	15
6	P13365	Divisão Central Esquerda	Central division Left	División Central izquierda	1	2357	578	15
7	P13369	Frente Pé	Frontal Botton Frame	Zocalo Frontal	2	906	70	15
8	P13370	Frente Pé	Frontal Botton Frame	Zocalo Frontal	1	879	70	15
9	P13330	Traseiro Pé	Back Botton Frame	Zocalo Traseiro	2	906	70	15
10	P13332	Traseiro Pé	Back Botton Frame	Zocalo Traseiro	1	879	70	15
11	P13310	Tampo	Top	Tapa	4	543	450	15
12	P11437	Tampo	Top	Tapa	1	879	450	15
13	P13312	Tampo	Top	Tapa	2	348	450	15
14	P13537	Tampo c/ Soberbão	Top c/ Soberbão	Top c/ Soberbão	2	348	450	15
15	P13307	Tampo Inferior / Inferior	Inf/Sup Top	Tapa Inf/Sup	2	879	578	15
16	P13306	Tampo Superior / Inferior	Inf/Sup Top	Tapa Inf/Sup	4	906	514	15
17	P11442	Tampo Sup. Gav. (1 lado sem pint)	Drawer Superior Top	Tapa superior del cajón	1	879	450	15
18	P13313	Prateleira	Shelf	Repisa	6	348	450	15
19	P13311	Prateleira	Shelf	Repisa	2	543	450	15
20	P14917	Distanciador	Spacer	Spacer	4	640	70	25
21	P13338	Fundo	Background	Fondo	2	2297	558	2,5
22	P13339	Fundo Central	Background	Fondo	2	2297	445	2,5
23	P13337	Fundo Lateral	Background	Fondo	2	2297	363	2,5
24	P11444	Traseiro Gaveta	Drawer Back	Traseiro Cajón	4	805,5	88	15
25	P11445	Fundo Gaveta	Drawer Back	Fondo Cajón	4	805,5	406	2,5
26	P10604	Lateral Gaveta	Drawer Side	Lateral Cajón	8	385	88	15
27	P11443	Frente Gaveta	Front drawer	Frente de cajón	4	822,5	135	15
28	P13361	Moldura Sup. Lateral	Frame Sup. Side	Frame Sup. Side	2	479	30	25
29	P13364	Moldura Sup. Central	Frame Sup. Central	Frame Sup. Central	1	909	124	25
30	P13363	Moldura Sup.	Frame Sup.	Frame Sup.	2	921	60	25

4749 - Roupeiro Unique New 6P Espelho Carvalho Sensitive

31	P13359	Porta Carvalho	Door	Puerta	2	2307	545	15
32	P13357	Porta Carvalho	Door	Puerta	2	2307	443	15
33	33673	Porta c/ Espelho Carvalho	Glass Door	Puerta	2	2307	360	15

4750/4752 - Roupeiro Requinte Glass 6P Carvalho Sensitive

31	P13359	Porta Carvalho	Door	Puerta	2	2307	545	15
32	P13357	Porta Carvalho	Door	Puerta	2	2307	443	15
33	P13659	Porta Carvalho	Door	Puerta	2	2307	360	15
34	33637	Espelho	Mirror	Espejo	2	1150	300	3
35	33638	Espelho	Mirror	Espejo	4	575	300	3

Medidas em mm



Cod.	Qt.	Descrição	Quantidade	Descrição	Quantidade	Descrição	Quantidade	Descrição	Quantidade	Descrição	Quantidade	Descrição	Quantidade	Descrição	Quantidade	Descrição	Quantidade	Descrição	Quantidade		
A	18	Parafuso 3,5x12 CP (P/ Suporte Cabideiro) 23416	18	Paraf. Corrediça 6x12 22396	16	Parafuso Minifix 25679	46	Tambor Minifix 22388	58	Cavilha 6x30 24603	44	Cantoneira Plástica 27097	16	Prego 10x10 CC 20179	180	Parafuso 4X14 CC 25673	96	Adesivo Logotipo THB 31363	1		
J	24	Calço p/ Dobradiça 23273	24	Parafuso Soberbão 7x40 PH 10 25691	34	Dobradiça Baixa 23271	16	Tampa Soberbão 26558 - Champ 33290 - Cavalho 23272	34	Dobradiça Alta 23272	8	Presilha Fundo 24099	60	Sapata Plástica 33257 - Carvalho	8	Suporte Cabideiro 20039	6	Suporte Prateleira 27098	32		
S	2	Parafuso 3,5x20 CF 33416 (2und embalados c/ Puxador Palio)	2	Parafuso 3,5x25 CF 33415 (8und embaladas c/Puxador Ornato)	8	Minifix Haste Dupla 25675	6	Puxador Ornato 800mm 33231	4	Puxador Ponto Palio 32413	2	Tapa Furo 5mm 29900 - Champ	8	Cabideiro Oblongoo 536 33188	2	Cabideiro Oblongoo 872 31252	1	Corrediça Telescópica Macho Esq. 31929	4		
AB	4	Corrediça Telescópica Macho Dir. 31929	4	Corrediça Telescópica Fêmea Esq. 31929	4	Corrediça Telescópica Fêmea Dir. 31929	4	Sachê de Cola 25676	2	Parafuso 3,5x35 CF 25762	22	Parafuso 3,5x14 CP 25736	64	Suporte Triangular 30094	8	Gabarito de Cabideiro 31514	1	Perfil H 2297 33189	1	Tampa Tambor 25682 - Champ	56



Atenção com a cor do acabamento!
Em caso de assistência solicitar o código de acordo com a cor da peça

Roupeiro Unique_Requinte 6 Portas / Wardrobe Unique_Requinte 6 Doors / Ropero Unique_Requinte 6 Puertas

1º Passo / Step / Paso

Na fixação dos Tamos, (11), (13), (14) e (16) usar Parafuso [K], Minifix [C] e Minifix haste Dupla [U] / In setting the types, (11), (13), (14) and (16) using screw [K], [C] and Minifix Minifix Aste Doubl [U] / Al fijar los tipos, (11), (13), (14) y (16) con el tornillo [K], [C] y Minifix Minifix Aste Doble [U].

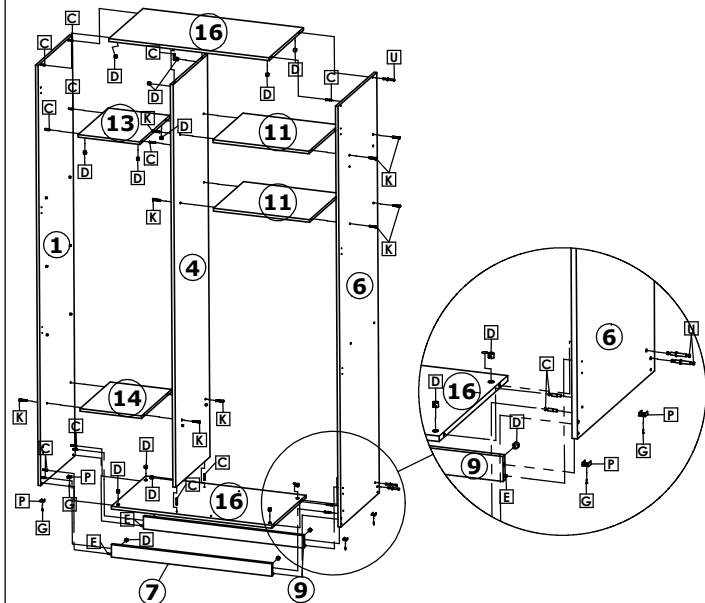

2º Passo / Step / Paso

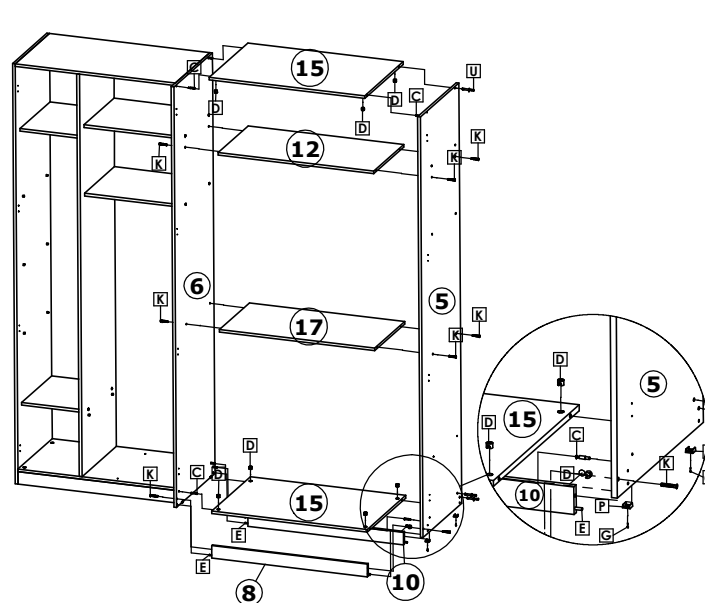

3º Passo / Step / Paso

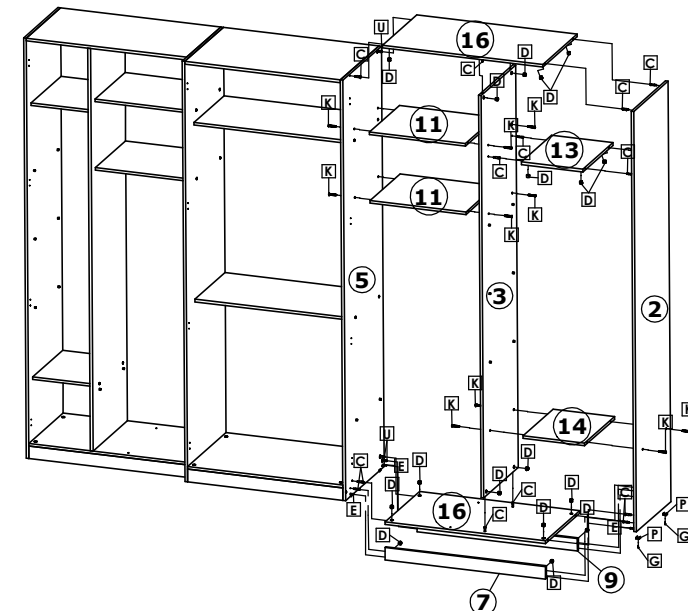

4º Passo / Step / Paso

Fixar os Fundos (21), (22) e (23) com prego [G], Presilha [Q] e Perfil H [AJ] / Fix the Funds (21), (22) and (23) with nail Clip [Q] and Profile H [AJ] / Fijar los Fondos (21), (22) y (23) con el clavo [G], Clip [Q] y Perfil H [AJ].

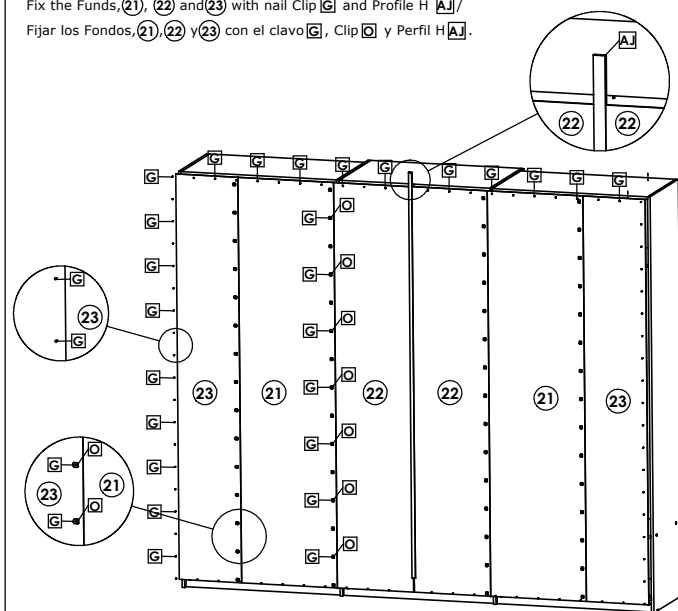

5º Passo / Step / Paso

Fixar as Molduras no Topo das Laterais (1) e (2) / Moldings fixar as Topo not give Laterais (1) e (2) / Fixar como Molduras sin Topo das Laterais (1) e (2).

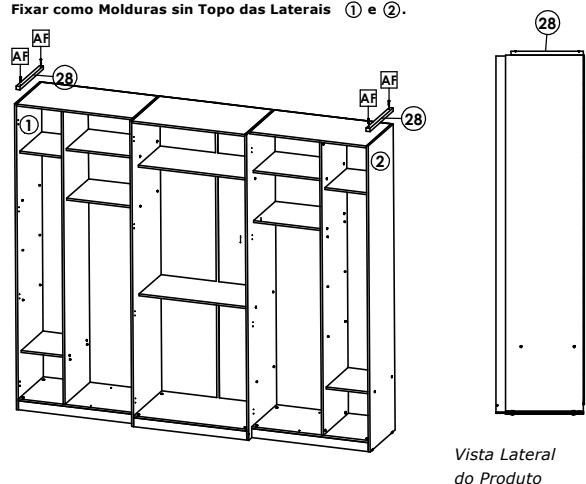

Vista Lateral do Produto



Fixação da Moldura Lateral (29) / Fixing Frame Side (29) / Fixação da Moldura lateral (29).

A Moldura Lateral deve ser alinhada com a parte traseira das Laterais (1) e (2) / A side trim deve be alinhada com traseira part to give Laterais (1) e (2) / Un Moldura lateral deve alinhada Ser com a parte traseira das Laterais (1) e (2).

6º Passo / Step / Paso

Alinhar as Molduras Frontais (30) com as Molduras Laterais (28) / Alinhar as (30) com as trim moldings Frontais Laterais (28) / Alinhar como Molduras Frontais (30) com Molduras Laterais (28).

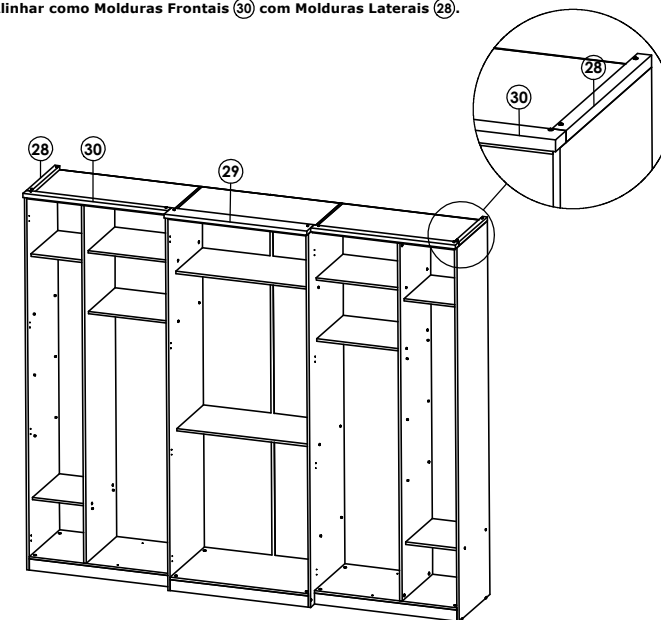

Roupeiro Unique_Requinte 6 Portas / Wardrobe Unique_Requinte 6 Doors / Ropero Unique_Requinte 6 Puertas

7º Passo / Step / Paso

Montagem do Distanciador/Mounting spacer/Montaje espaciador.



Alinhar o Distanciador (28) ao Tampo (17) e fazer a fixação com o Parafuso AF/
Align the spacer (28) to (17) Surface and make fixing with screw AF/
Alinee el espaciador del (28) al (17) de superficie y dar a la fijación con tornillo de AF.

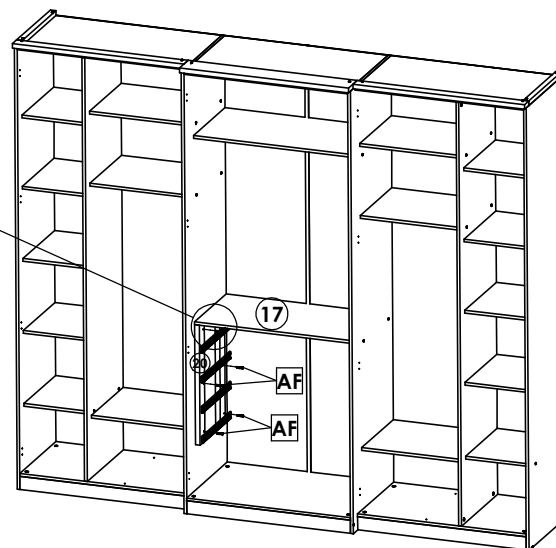
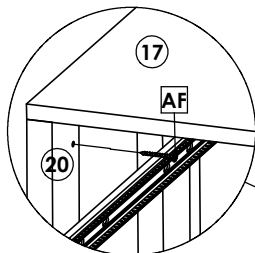
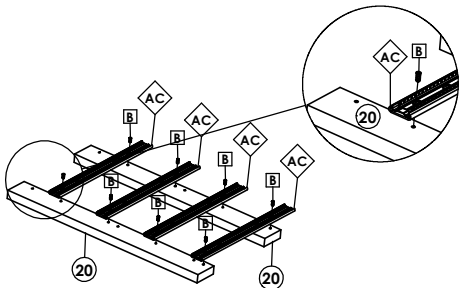

Montagem da Gaveta/Mounting Drawer /Montaje del cajón.

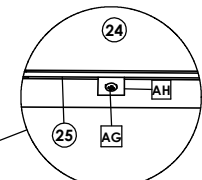
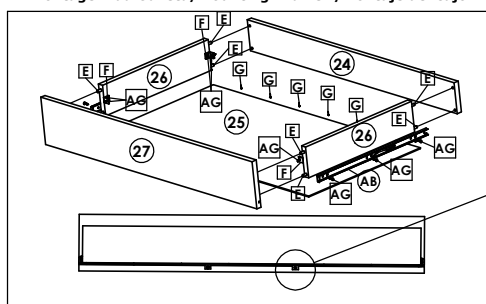

Segurança do Fundo Gaveta (25)/
Security Drawer Fund(25)/
Fondo de cajón de Seguridad (25).



8º Passo / Step / Paso

Inserindo Prateleiras, Gavetas e Cabideiros/
Inserting shelves, drawers and Coat Racks/
Inserción de estantes, cajones y Bastidores Coat.

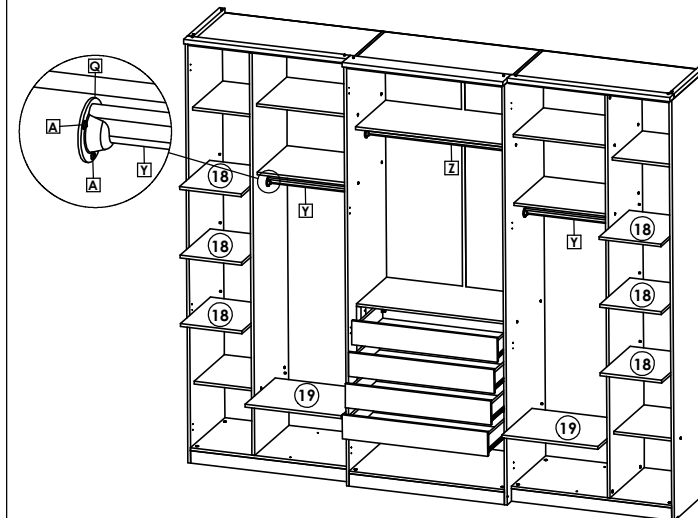

9º Passo / Step / Paso

Peso Suportado / Weight supported / peso que soporta

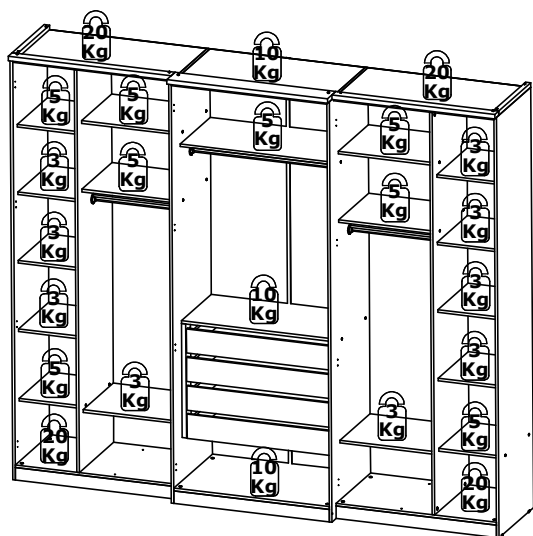

Peso Suportado por Gaveta/
Supported by weight Drawer/
Con el apoyo de cajón de peso.



Montagem Portas Unique / Unique Doors / Puertas Unique

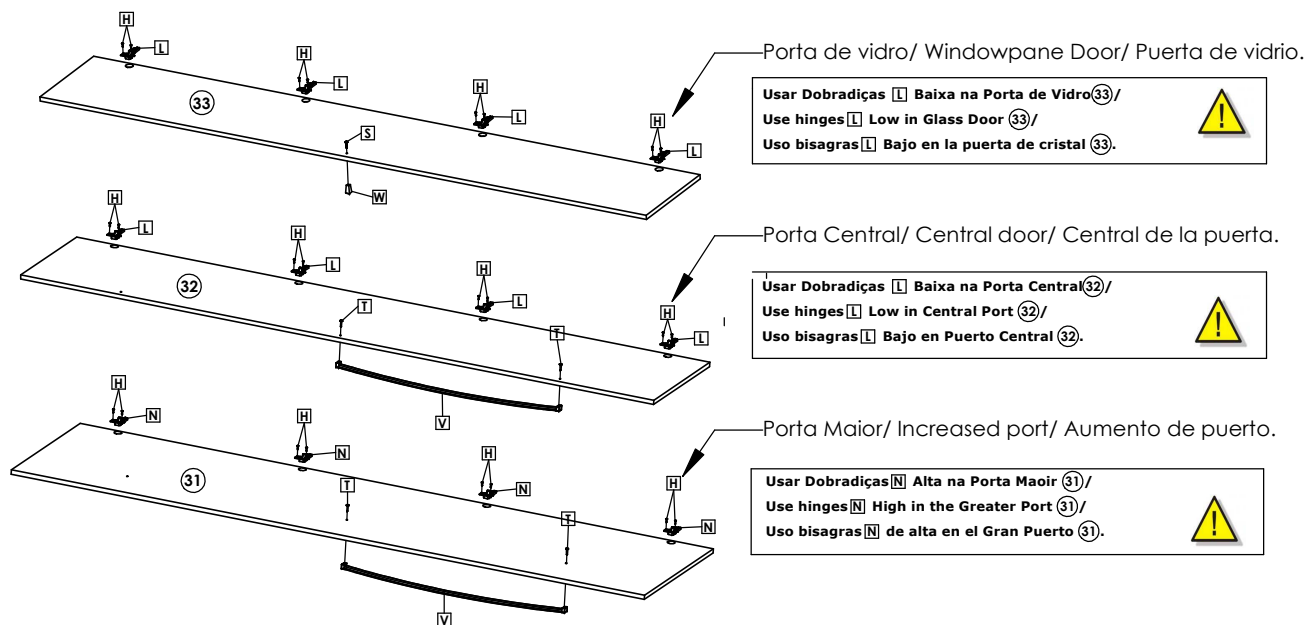

Porta de vidro/ Windowpane Door/ Puerta de vidrio.

Usar Dobradiças L Baixa na Porta de Vidro(33)/
Use hinges L Low in Glass Door (33)/
Usa bisagras L Bajo en la puerta de cristal (33).



Porta Central/ Central door/ Central de la puerta.

Usar Dobradiças L Baixa na Porta Central(32)/
Use hinges L Low in Central Port (32)/
Usa bisagras L Bajo en Puerto Central (32).



Porta Maior/ Increased port/ Aumento de puerto.

Usar Dobradiças N Alta na Porta Maior (31)/
Use hinges N High in the Greater Port (31)/
Usa bisagras N de alta en el Gran Puerto (31).



Roupeiro Unique_Requinte 6 Portas / Wardrobe Unique_Requinte 6 Doors / Ropero Unique_Requinte 6 Puertas

10º Passo / Step / Paso



ATENÇÃO
HEADS UP
PRECAUCIÓN

As Portas 33 e 32 devem ser fixadas com Dobradiças L e Calço J /
Ports 33 and 32 must be secured with Hinges L and chock J /
Puertos 33 y 32 deben asegurarse con bisagras L y bloquee J.

A Portas 31 deve ser fixada com Dobradiças Altas N e Calço J /
The doors 31 must be secured with hinges High N and chock J /
Las puertas 31 deben asegurarse con bisagras de alta N y hasta los topes J.

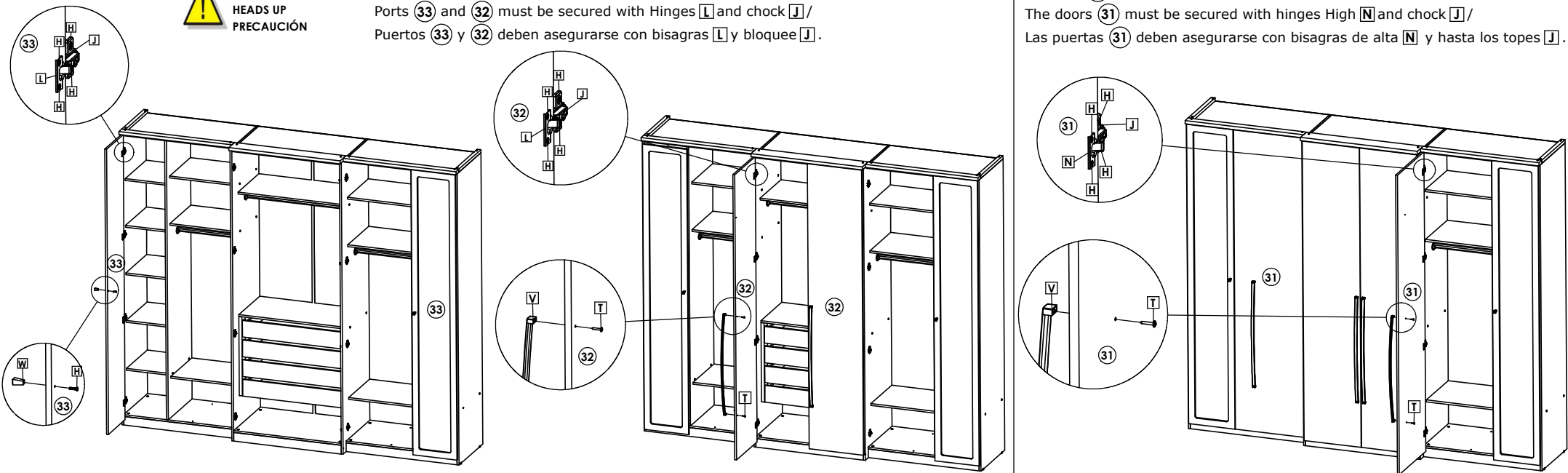

- Versão Requinte com Espelhos:

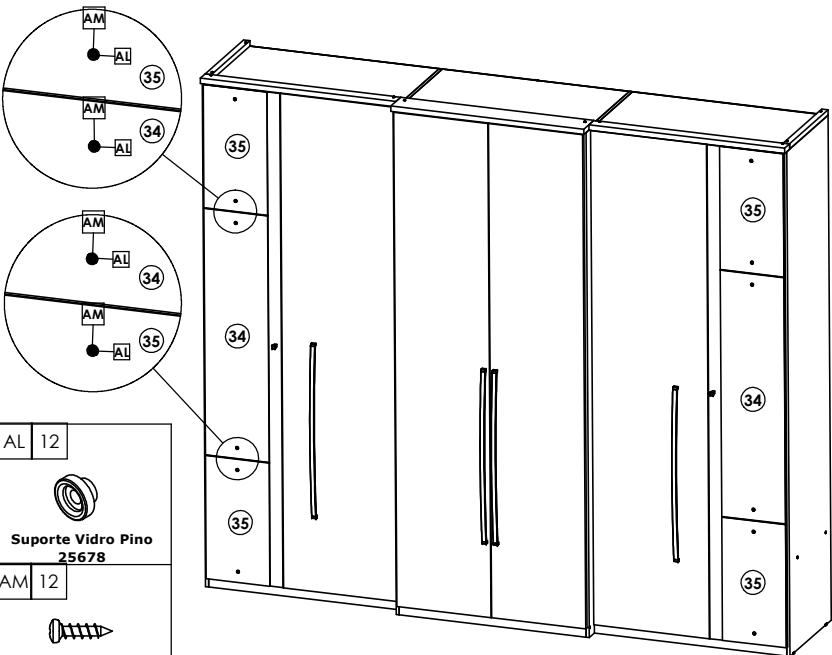

AL 12



Suporte Vidro Pino
25678

AM 12



Parafuso 3,5x15 CP
33067

Unique Espelhos/Reflecta 6P

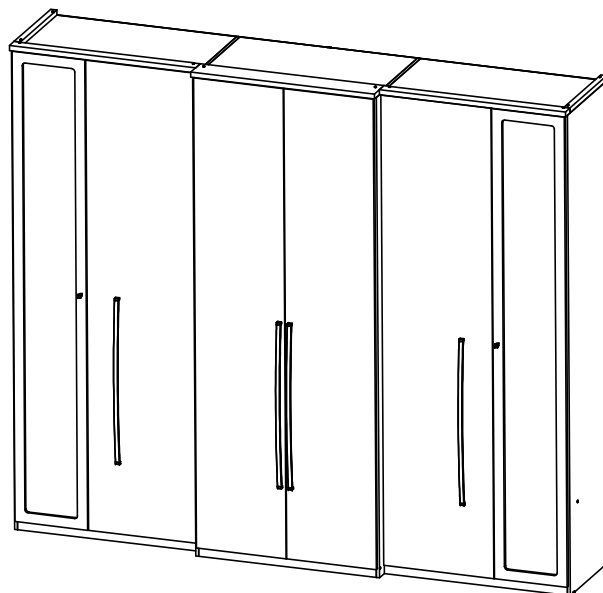

Requinte Glass 6P

