

**CÓDIGO DE PEÇAS | CODE OF PIECES | CÓDIGO DE PIEZAS**

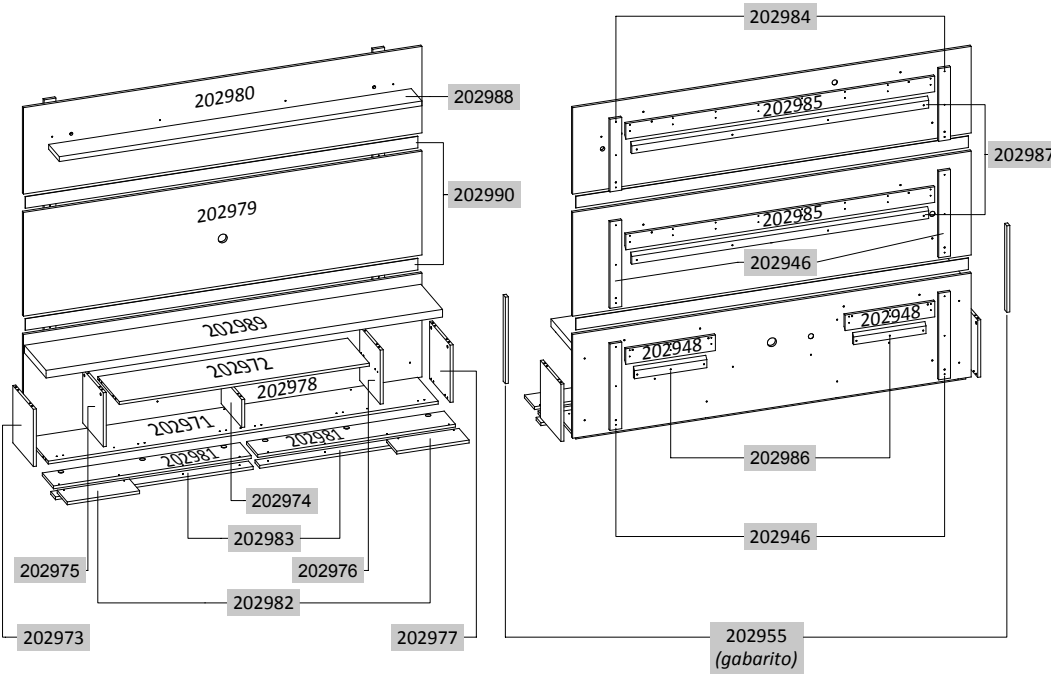

**INSTRUÇÕES**

- Prepare a montagem do móvel próximo ao local que ele ficará definitivamente e evite deslocá-lo depois de montado;  
- Forre o chão com papelão ou similar e utilize a isomanta que vem entre as peças para evitar o contato entre elas durante a montagem;  
- Monte o móvel obedecendo a ordem numérica da **seqüência de montagem (S.M.)**, identificando as peças pelo **código de peça (C.P.)** carimbado na mesma, de acordo com a tabela.

**INSTRUCTIONS**

- Prepare the assembly of the close piece of furniture to the place that it will be definitively and avoid to move after done. Will be definitively and avoid to move after done;  
- Cover the ground with cardboard or similar and use the isomanta that it comes among the pieces to avoid the contact among them during the assembly;  
- Set up the piece of furniture obeying the numeric order of the **assembly sequence (S.M.)**, identifying the pieces by **code of piece (C.P.)** stamped in the same, in agreement with the table.

**INSTRUCCIONES**

- Prepare la montaje del mobiliario proximo al lugar que estará definitivamente y evite mover después de hecho;  
- Tape la suelo con cartón o similar y use la "isomanta" que viene entre las piezas para evitar el contacto entre ellos durante la montaje;  
- Monte el mobiliario obedeciendo el orden numérico de la **sucesión de montaje (S.M.)**, identificando las piezas por el **código de piezas (C.P.)** de la misma estampado en esta, de acuerdo con la tabla.

**ASPECTO FINAL | FINAL ASPECT**

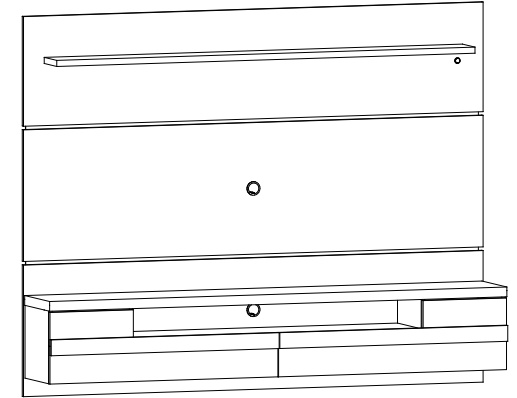

\*Dimensões em metros | *Dimensions in meters* | *Dimensiones en metros*

Edição: 08/11/2017

Espaço para Tv: → 2,000 m ↑ 0,950 m  
Dimensão do Produto: → 2,000 m ↑ 1,560 m ↖ 0,330 m

REF.:	PEÇAS PIECE PIEZA	MATÉRIA PRIMA	DIMENSÕES* DIMENSIONS DIMENSIONES	QUANT.
202971	Base   Base   Base	MDP	1,957 x 0,283 x 0,015	1
202972	Prateleira DVD   Shelf DVD   Estantería de DVD	MDP	1,255 x 0,298 x 0,015	1
202973	Lateral esquerda   Left side   Lateral izquierdo	MDP	0,298 x 0,283 x 0,015	1
202974	Divisão inferior central   Central bottom division   División inferior central	MDP	0,283 x 0,145 x 0,015	1
202975	Divisão esquerda   División esquerda   División izquierda	MDP	0,283 x 0,281 x 0,015	1
202976	Divisão direita   Right Division   División derecha	MDP	0,283 x 0,281 x 0,015	1
202977	Lateral direita   Right side   Lateral derecho	MDP	0,298 x 0,283 x 0,015	1
202978	Painel inferior   Bottom panel   Panel inferior	MDP	2,000 x 0,540 x 0,015	1
202979	Painel central   Central panel   Panel central	MDP	2,000 x 0,540 x 0,015	1
202980	Painel superior   Superior panel   Panel superior	MDP	2,000 x 0,450 x 0,015	1
202981	Parte inferior da porta   Bottom of door   Parte inferior de la puerta	MDP	0,992 x 0,065 x 0,015	2
202982	Complemento sup. porta   Top door complement   Complemento sup. puerta	MDP	0,363 x 0,139 x 0,015	2
202983	Complemento frontal porta   Front door complement   Complemento frontal puerta	MDP	0,992 x 0,065 x 0,015	2
202946	Travessa lateral maior   Largest side crossbar   Travesa lateral mayor	MDP	0,450 x 0,059 x 0,015	4
202984	Travessa lateral menor   Minor side guard   Travesaño lateral menor	MDP	0,378 x 0,059 x 0,015	2
202948	Apoio do painel menor   Small panel support   Apoyo panel pequeño	MDP	0,450 x 0,081 x 0,015	2
202985	Apoio do painel maior   Largest panel support   Apoyo panel mayor	MDP	1,550 x 0,081 x 0,015	2
202986	Apoio da parede menor   Lower wall support   Apoyo pared más pequeño	MDP	0,363 x 0,058 x 0,015	2
202987	Apoio da parede maior   Larger wall support   Soporte del pared	MDP	1,490 x 0,058 x 0,015	2
202988	Prateleira superior   Top shelf   Estantería superior	MDP	1,820 x 0,147 x 0,025	1
202989	Tampo   Top   Table top	MDP	1,990 x 0,298 x 0,040	1
202990	Fundo complemento   Bottom background   Fondo complementario	MDF	1,970 x 0,060 x 0,003	2
202955	Gabarito para fixar cunha   Fixing wedge jig   Plantilla para fijar cuña	MDP	0,448 x 0,030 x 0,015	2

**ACESSÓRIOS | ACCESSORIES | ACESORIOS**

<b>A</b> Parafuso 5,0x70 14x	<b>F</b> 32x Cavilha 6x30mm	<b>G</b> 18x Pino girofix	<b>H</b> 18x Castanha girofix	<b>i</b> 12x Porca metálica
<b>B</b> Parafuso 5,0x50 (Estrutural) 22x	<b>J</b> 6x Dobradiça reta	<b>K</b> 2x Passa fio	<b>L</b> 14x Buchas p/ parede	<b>M</b> 1x Luminária LED
<b>C</b> Parafuso 3,5x25 76x	<b>N</b> 1x Giz de correção	<b>O</b> 10x Tapa furo adesivo	<b>P</b> 4x Sache de cola	<b>Q</b> 1x Logomarca
<b>D</b> Parafuso p/ puxador 12x				
<b>E</b> Parafuso 3,5x14 40x				

**1º PASSO | PASS | PASO**

PEÇAS  
PIECES  
PIEZAS

S.M.	C.P.
01	202971
02	202973
03	202977
04	202974
05	202972
06	202975
07	202976
08	202989

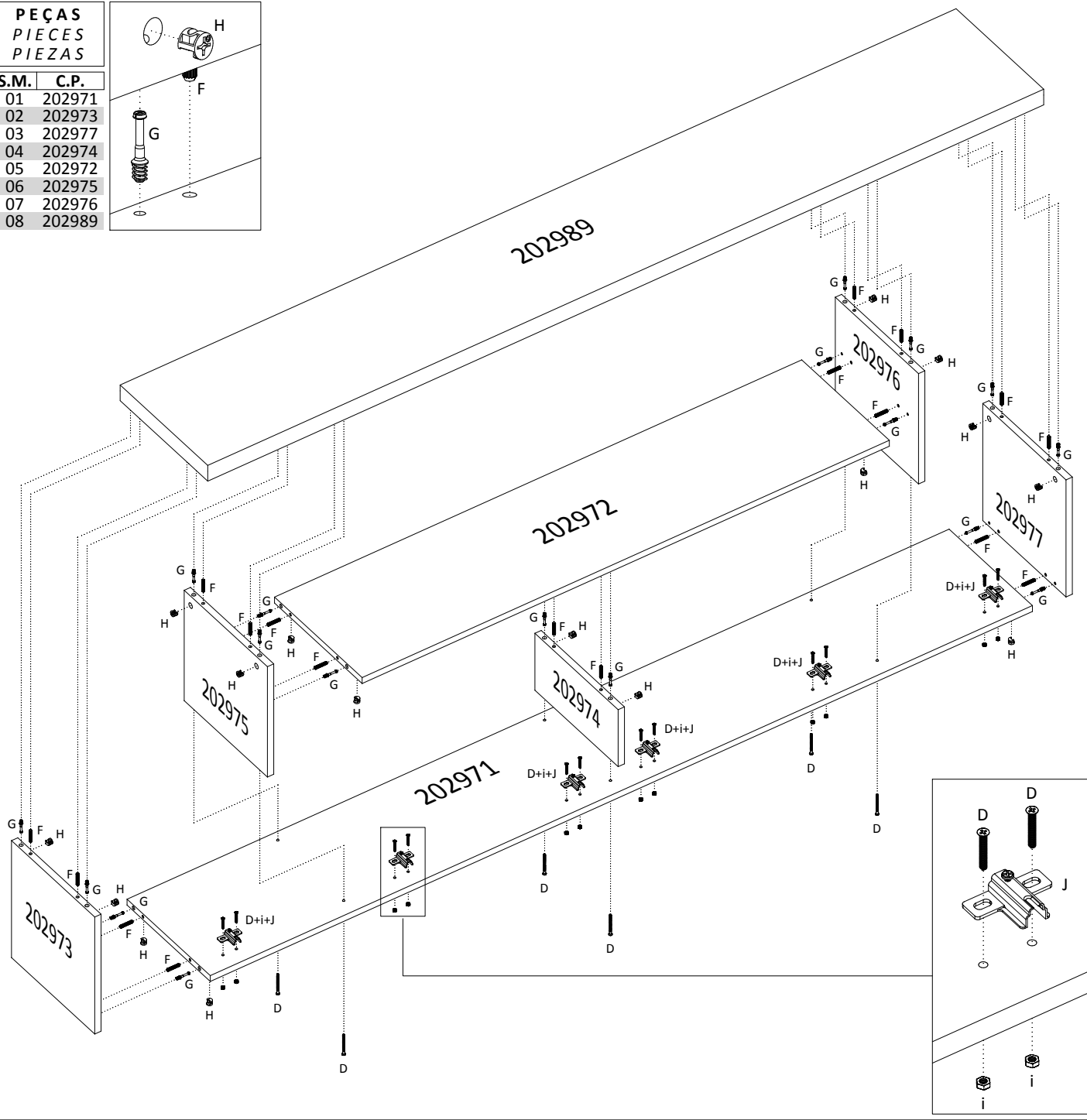
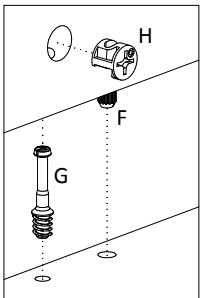

**2º PASSO | PASS | PASO**

PEÇAS  
PIECES  
PIEZAS

S.M.	C.P.
01	202981
02	202983
03	202982

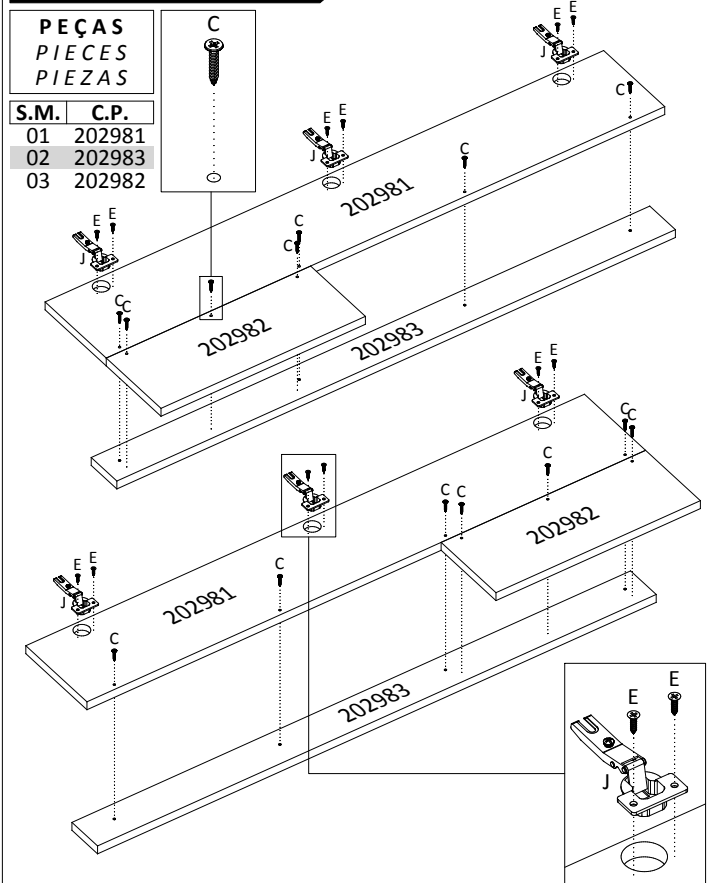

**3º PASSO | PASS | PASO**

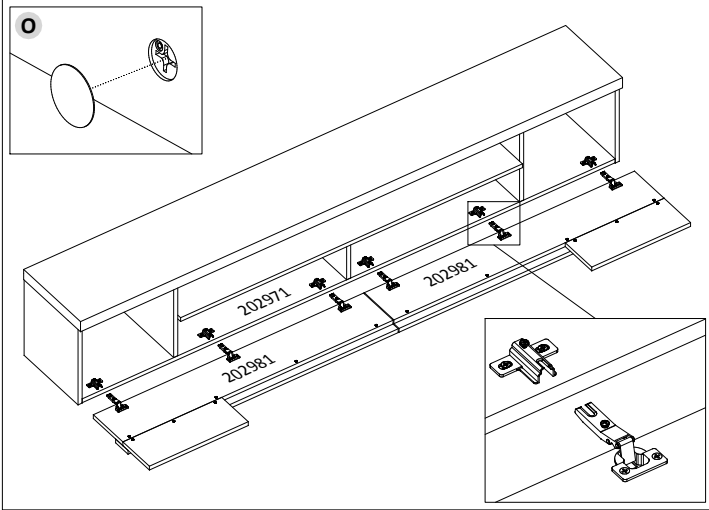

**4º PASSO | PASS | PASO**

PEÇAS  
PIECES  
PIEZAS

S.M.	C.P.
01	202978
02	202948
03	202948
04	202946
05	202946

Obs.: passar cola [P] nas peças 202948 antes de fixa-las no painel.

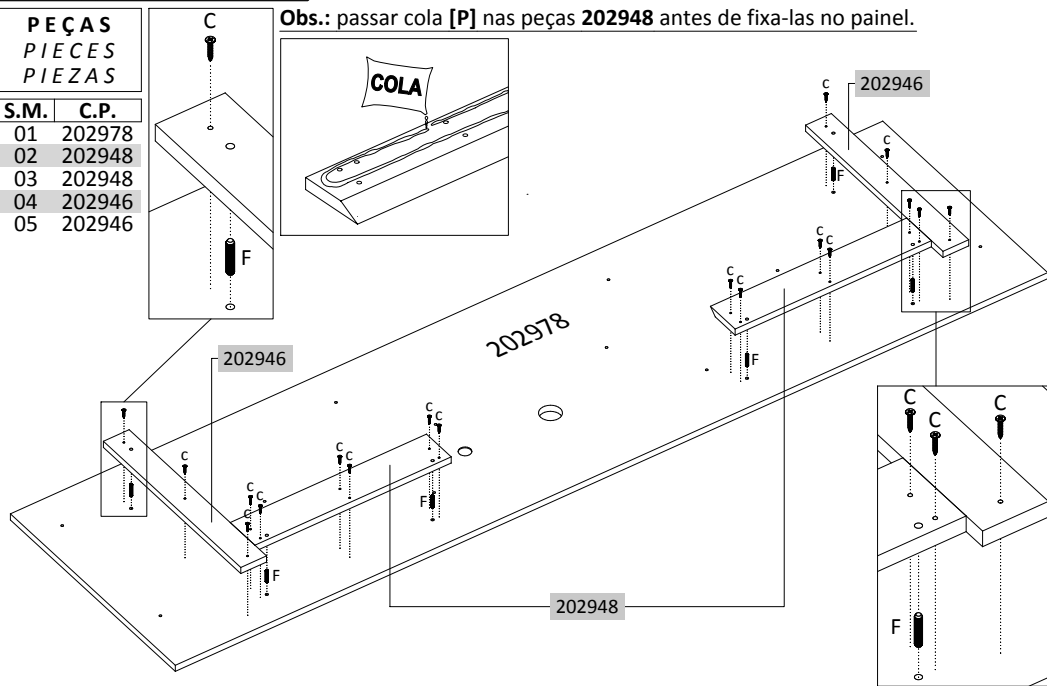
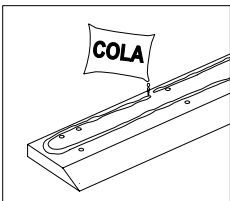

**5º PASSO | PASS | PASO**

PEÇAS  
PIECES  
PIEZAS

S.M.	C.P.
01	202990

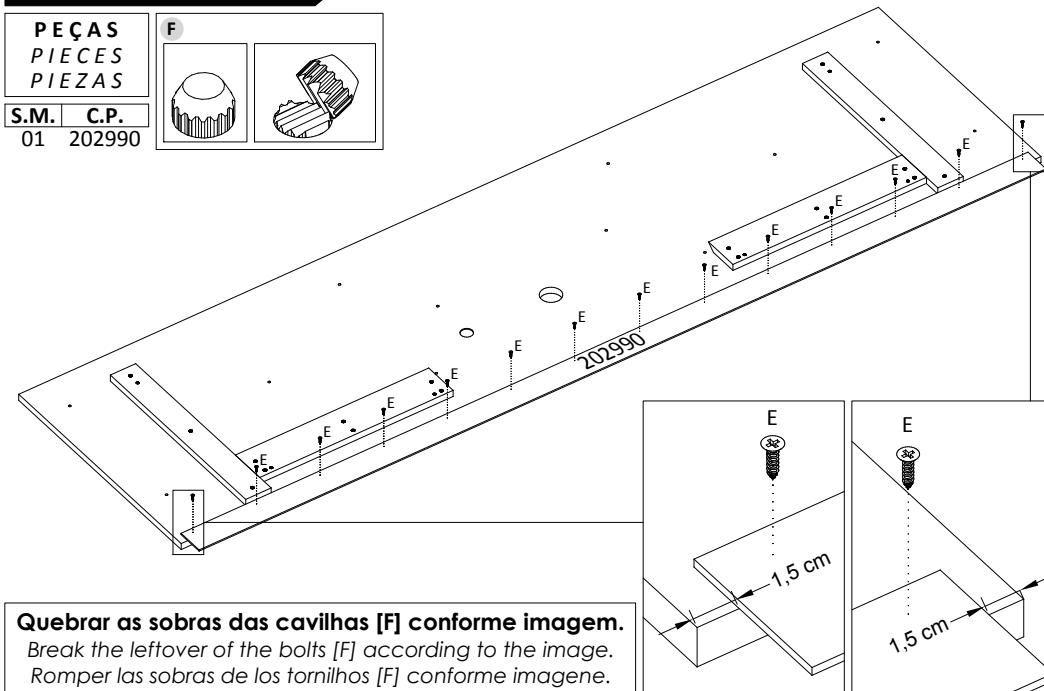
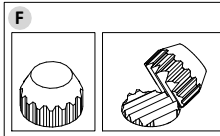

Quebrar as sobras das cavilhas [F] conforme imagem.  
Break the leftover of the bolts [F] according to the image.  
Romper las sobras de los tornillos [F] conforme imagene.

**6º PASSO | PASS | PASO**

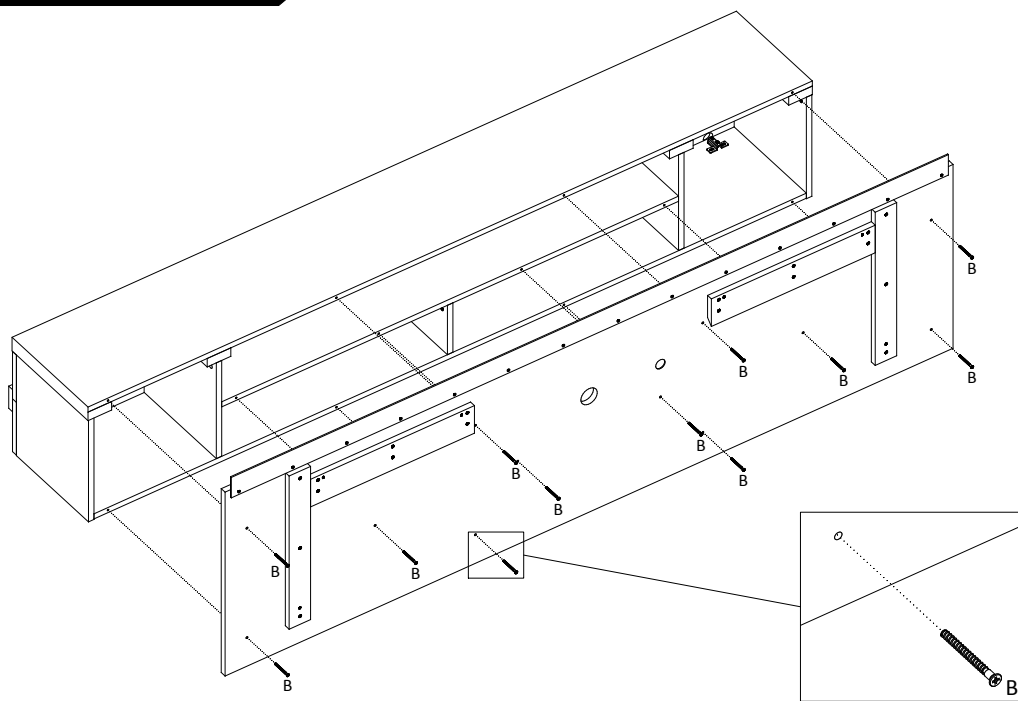

**7º PASSO | PASS | PASO**

Obs.: passar cola [P] na peça 202985 antes de fixa-la no painel.

PEÇAS  
PIECES  
PIEZAS

S.M.	C.P.
01	202979
02	202985
03	202946
04	202946

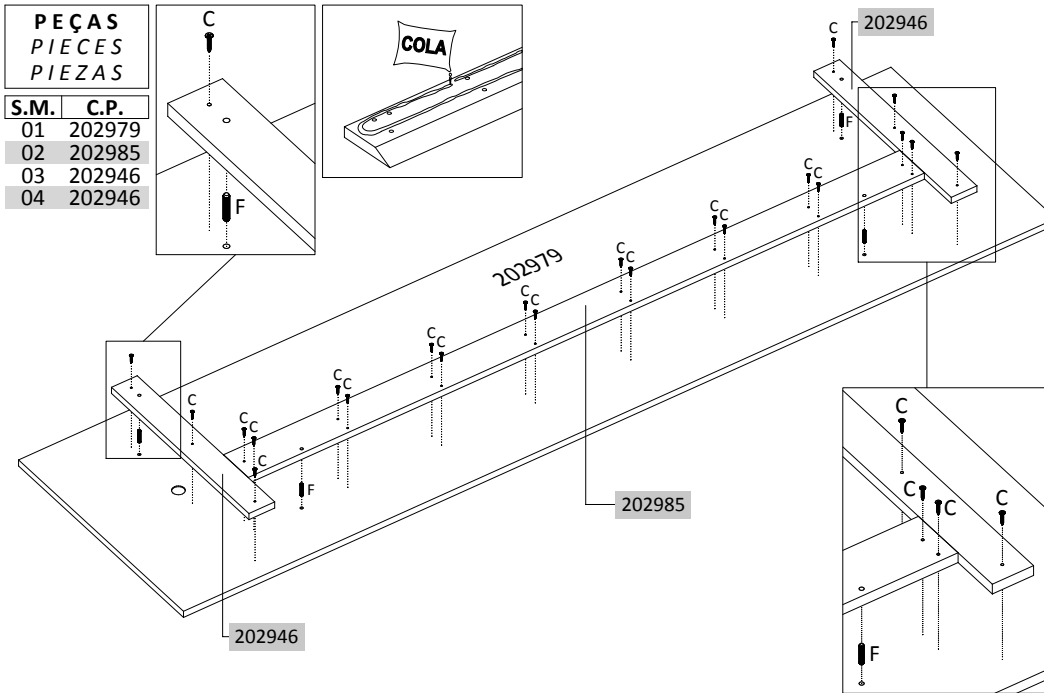
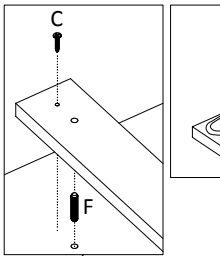

**8º PASSO | PASS | PASO**

PEÇAS  
PIECES  
PIEZAS

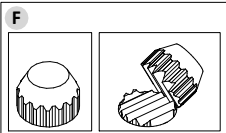

S.M.	C.P.
01	202990

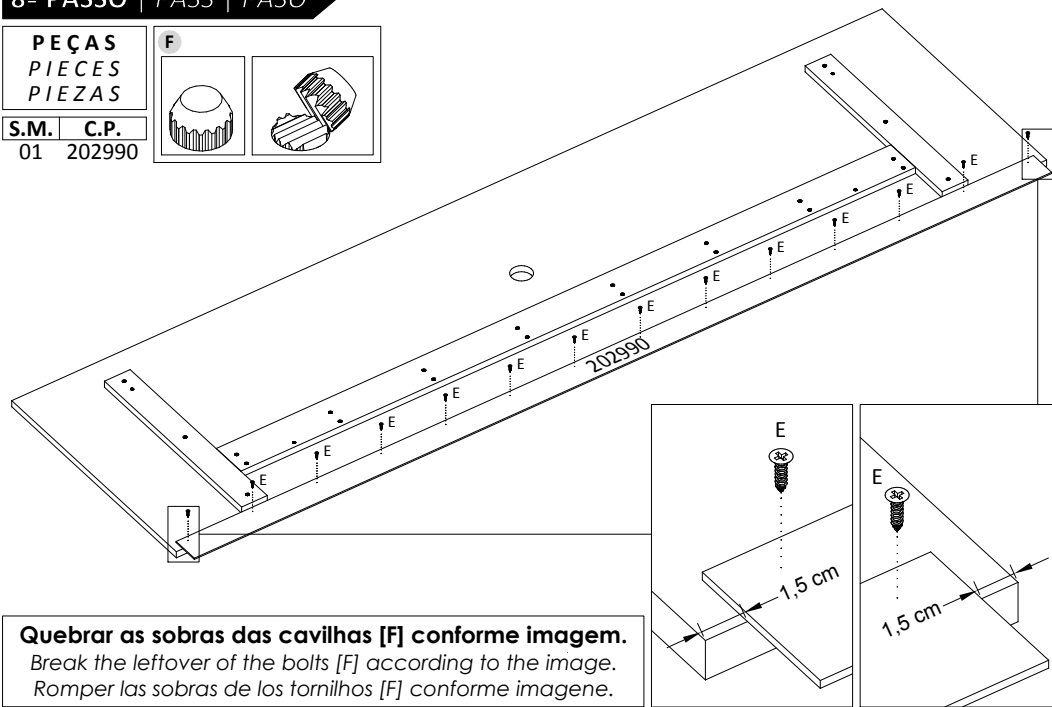

**Quebrar as sobras das cavilhas [F] conforme imagem.**

*Break the leftover of the bolts [F] according to the image.*

*Romper las sobras de los tornillos [F] conforme imagen.*

**9º PASSO | PASS | PASO**

PEÇAS  
PIECES  
PIEZAS

**Obs.: passar cola [P] na peça 202985 antes de fixa-la no painel.**

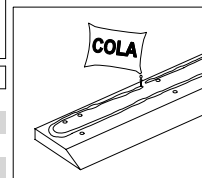

S.M.	C.P.
01	202980
02	202985
03	202984
04	202984

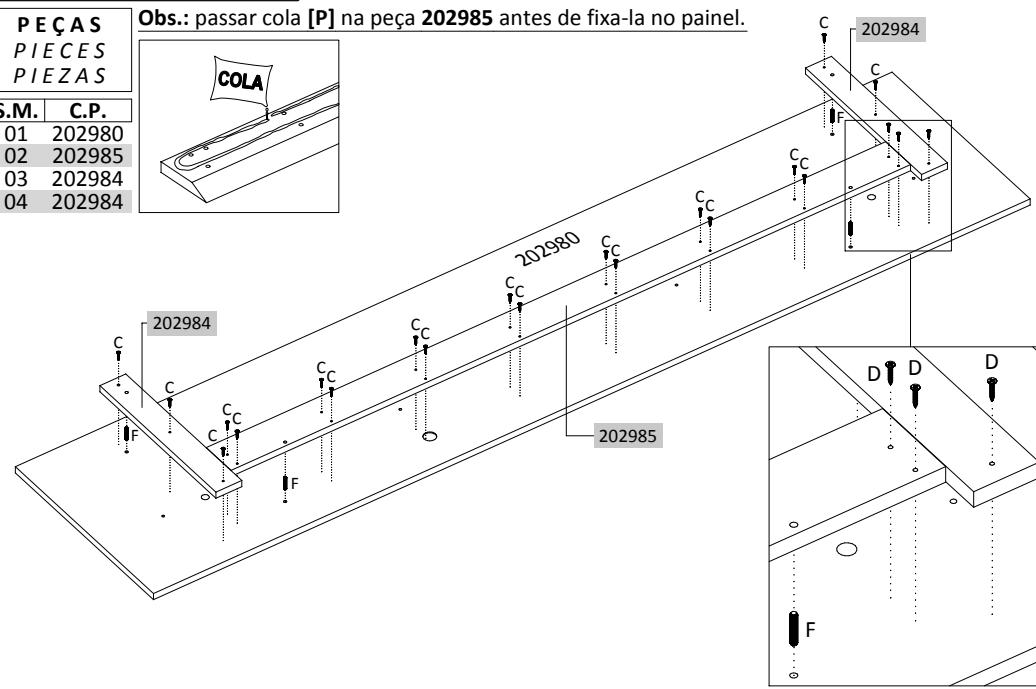

**10º PASSO | PASS | PASO**

PEÇAS  
PIECES  
PIEZAS

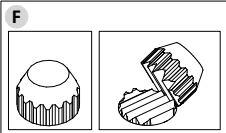

S.M.	C.P.
01	202988

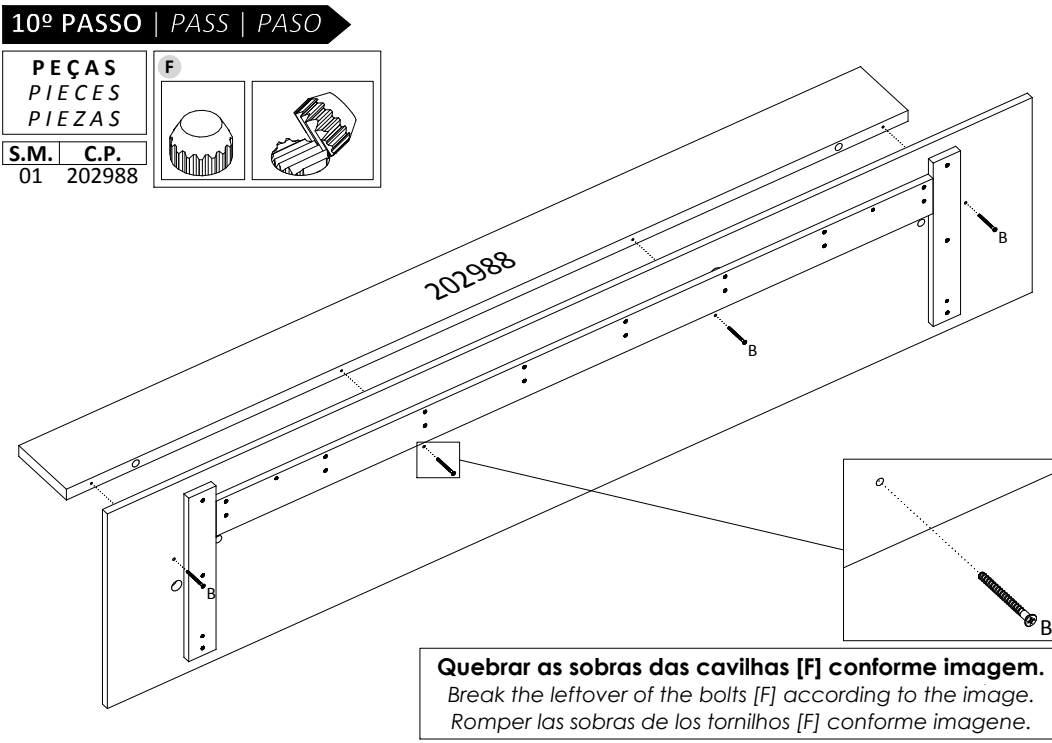

**Quebrar as sobras das cavilhas [F] conforme imagem.**

*Break the leftover of the bolts [F] according to the image.*

*Romper las sobras de los tornillos [F] conforme imagen.*

**11º PASSO | PASS | PASO**

**Comece a instalação da luminária encaixando o interruptor no furo do painel e depois passe o fio pelo segundo furo.**

*Start the installation of the luminaire fitting the switch in the top hole and then pass the string through the second hole.*

*Comienza la instalación del montaje del interruptor en el orificio superior de la luminaria y luego pasar la cadena a través del segundo agujero.*

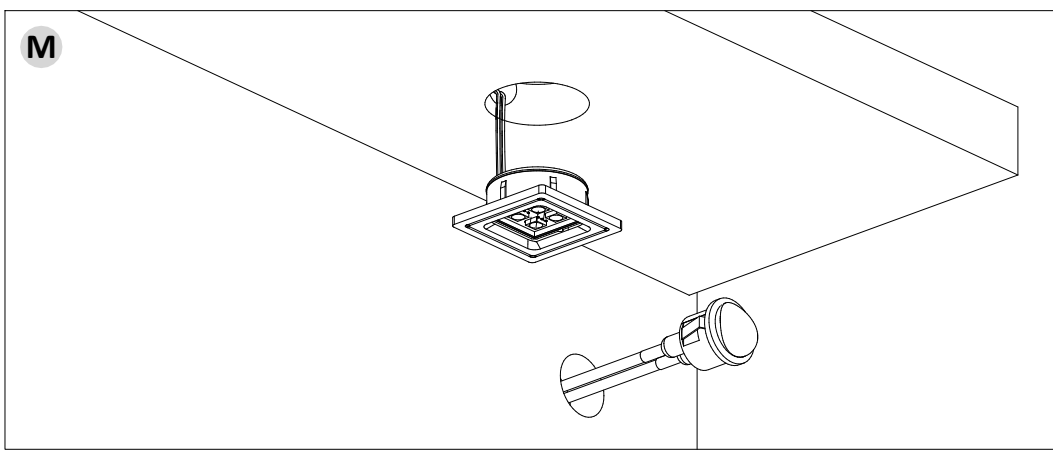

12º PASSO | PASS | PASO

PEÇAS  
PIECES  
PIEZAS

S.M.	C.P.
01	202986
02	202986
03	202987
04	202987

Parede | Wall | Pared

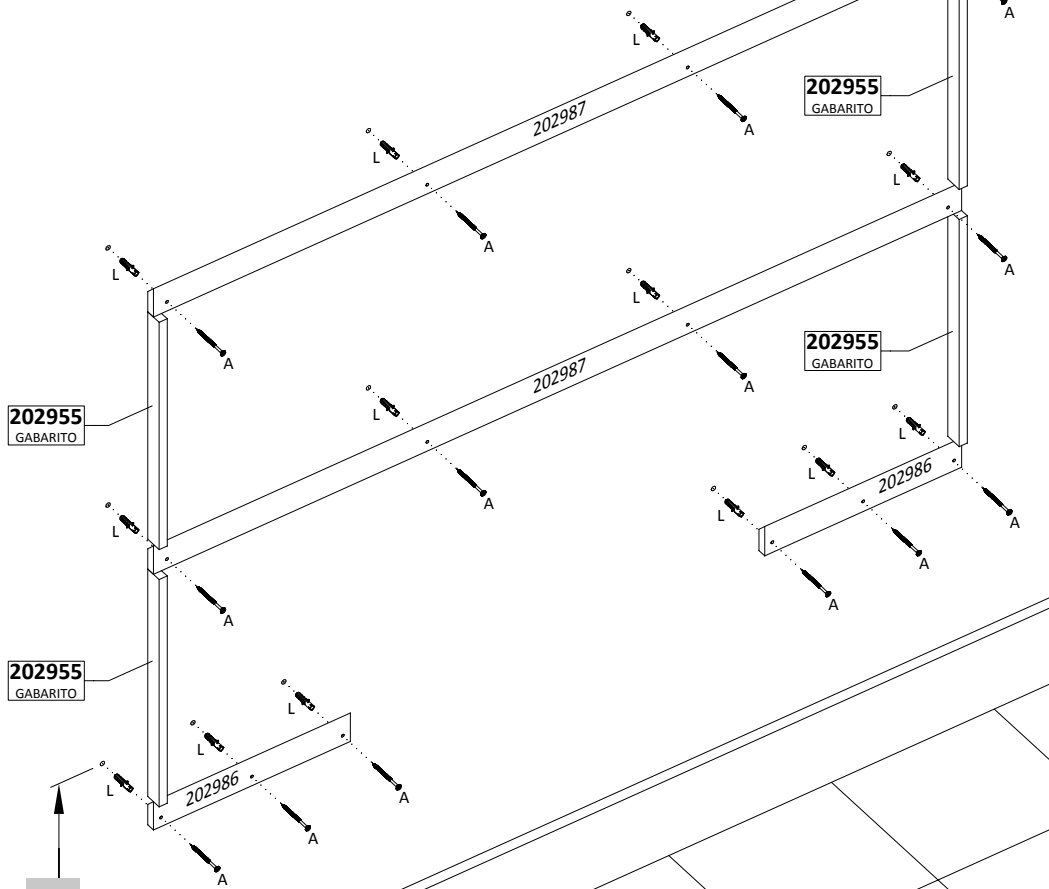

0,665 m

**Medida até o furo**  
Measure until the hole  
Mide hasta que el agujero

ALTURA RECOMENDADA  
RECOMMENDED HEIGHT  
ALTURA RECOMENDADA

13º PASSO | PASS | PASO

Parede | Wall | Pared

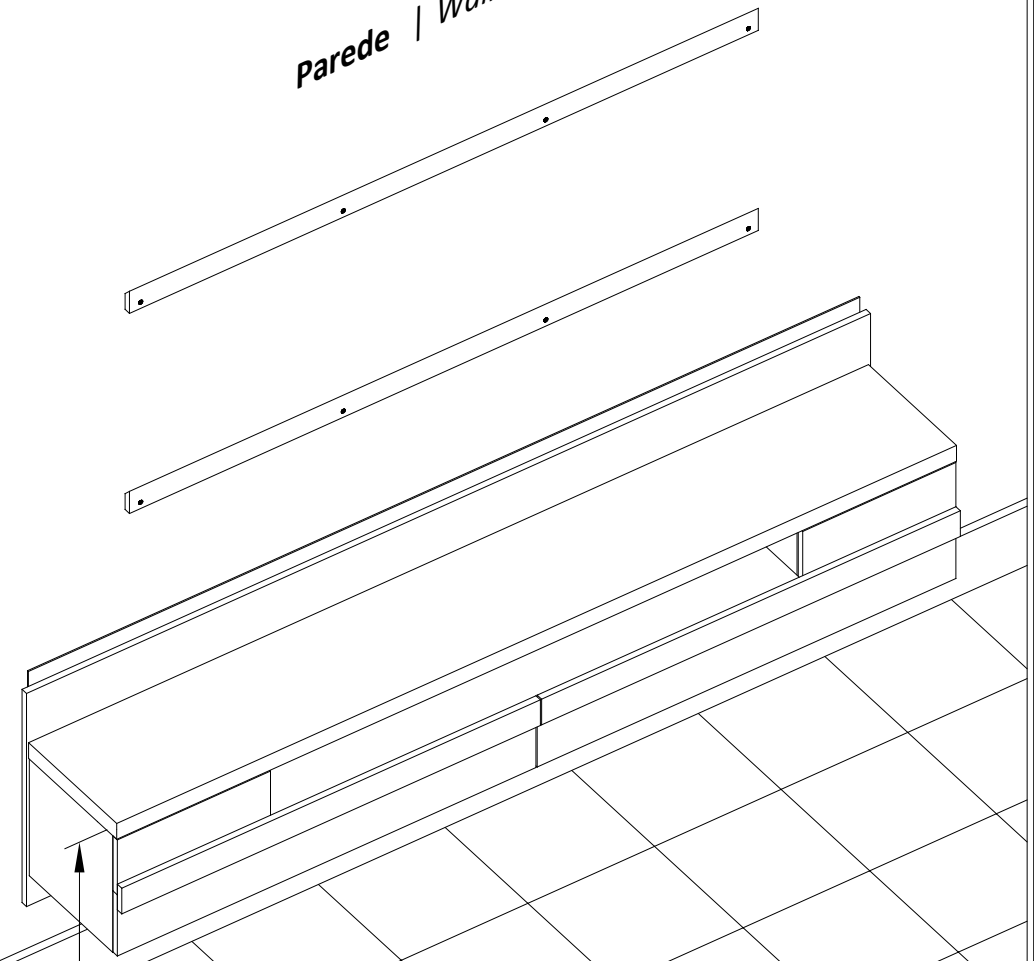

0,700 m

14º PASSO | PASS | PASO

parede | Wall | Pared

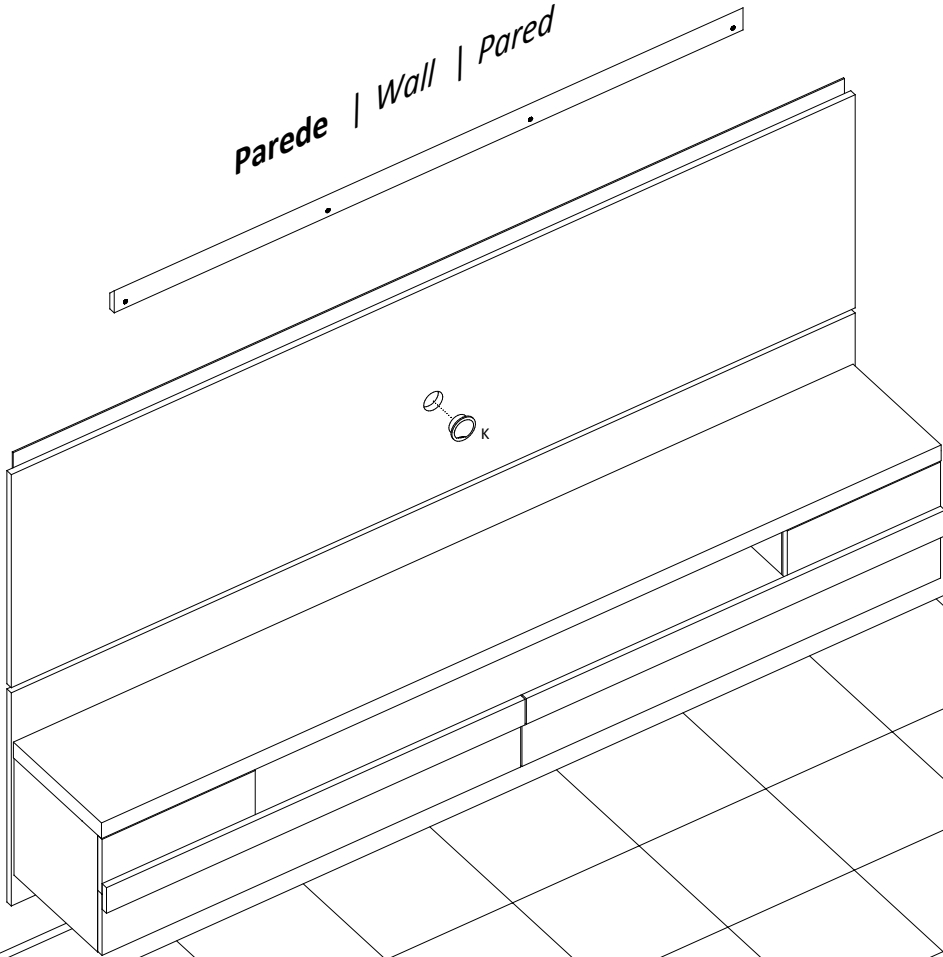

15º PASSO | PASS | PASO

R

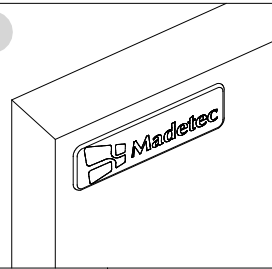

parede | Wall | Pared

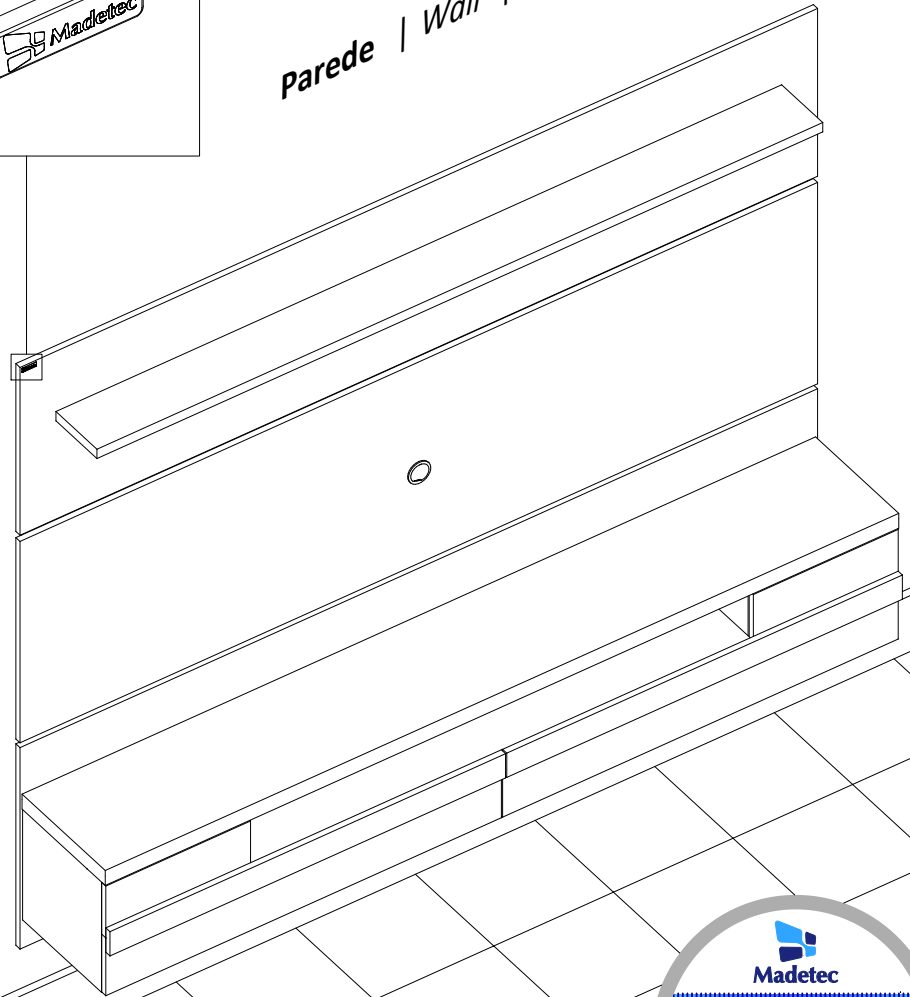

Este produto  
deve ser usado  
com a TV fixada  
no painel.

**CUIDADOS ESPECIAIS | SPECIAL CARES | CUIDADOS ESPECIALES:**

**LIMPEZA:** Pano limpo umedecido em água e sabão neutro - **BRILHO:** Flanela seca

**CLEANING:** Clean cloth humidified in water and neutral soap - **SHINE:** Dry flannel

**LIMPIEZA:** Tela limpia humedecida en la agua y el jabón neutro - **BRILLO:** Franela seca