

ARTESANO

Criador de Ambientes

Dicas de Conservação / Maintenance Tips / Dicas para Conservación

*Para limpar ou tirar manchas, utilize uma flanela umedecida em solução de água e álcool, na mesma proporção.

*Evite exposição ao sol.

*To clean or remove stains, use a piece of flannel dampened with a water and alcohol solution, in the same proportion.

*Avoid direct sunlight.

*Para limpiar o sacar manchas, utilice una flanela humedecida en solución de agua y alcohol, en la misma proporción.

*Evite la exposición directa al sol.

REF.: 12520

ARTESANO
Criador de Ambientes

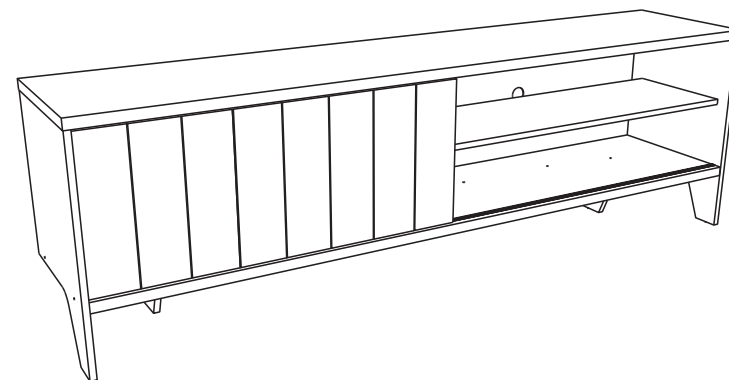

INSTRUÇÕES DE MONTAGEM ASSEMBLING INSTRUCTIONS / INSTRUCCIONES DE MONTAJE

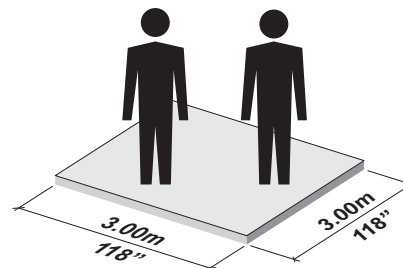









60 min.

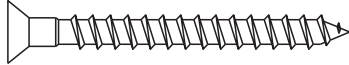

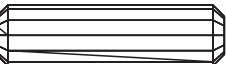
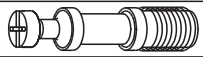
ARTESANO MÓVEIS LTDA.
Estrada da Uva e do Vinho, nº 2347, Bairro São Valentim
Caixa Postal 509 - CEP 95709-210
Bento Gonçalves - RS - Brasil
Fone: +55 54 3458 3400
e-mail: artesano@artesano.com.br

www.artesano.com.br

FERRAGENS
HARDWARE LIST
LISTA DE MATERIALES

A			4,5 x 45mm	15
B			3,5 x 12mm	12
C			8 x 30mm	12
D				03
E				03
F			8 x 8	16
G				02
H				02
I			8 x 10	04
J				04

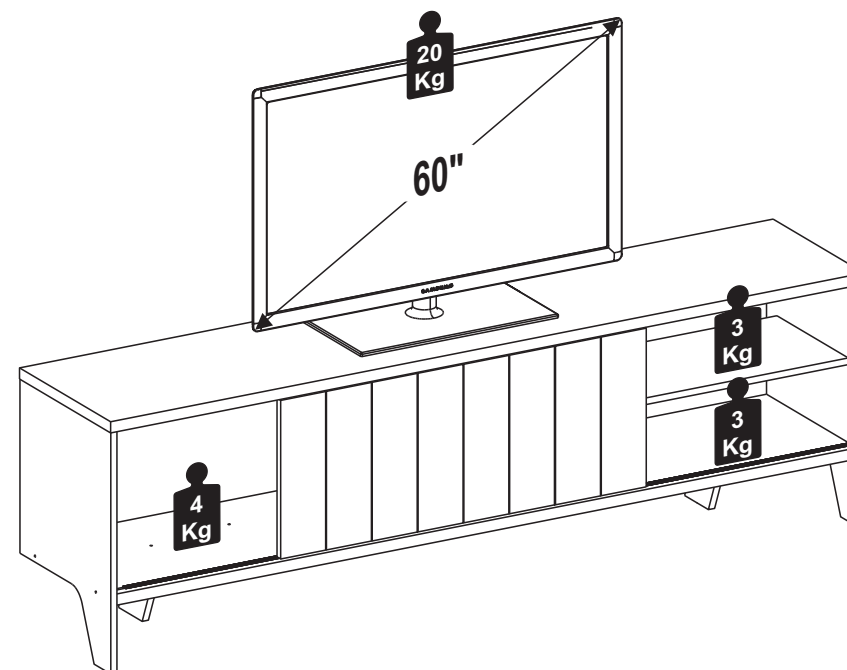

MONTE O MÓVEL COMO NÓS O PRODUZIMOS: COM CARINHO.

ASSEMBLE THE FURNITURE AS WE PRODUCE IT: WITH LOVE.

MONTE EL MUEBLE COMO NOSOTROS LO PRODUCIMOS: CON CARÍÑO.

9 Passo
Step
Paso

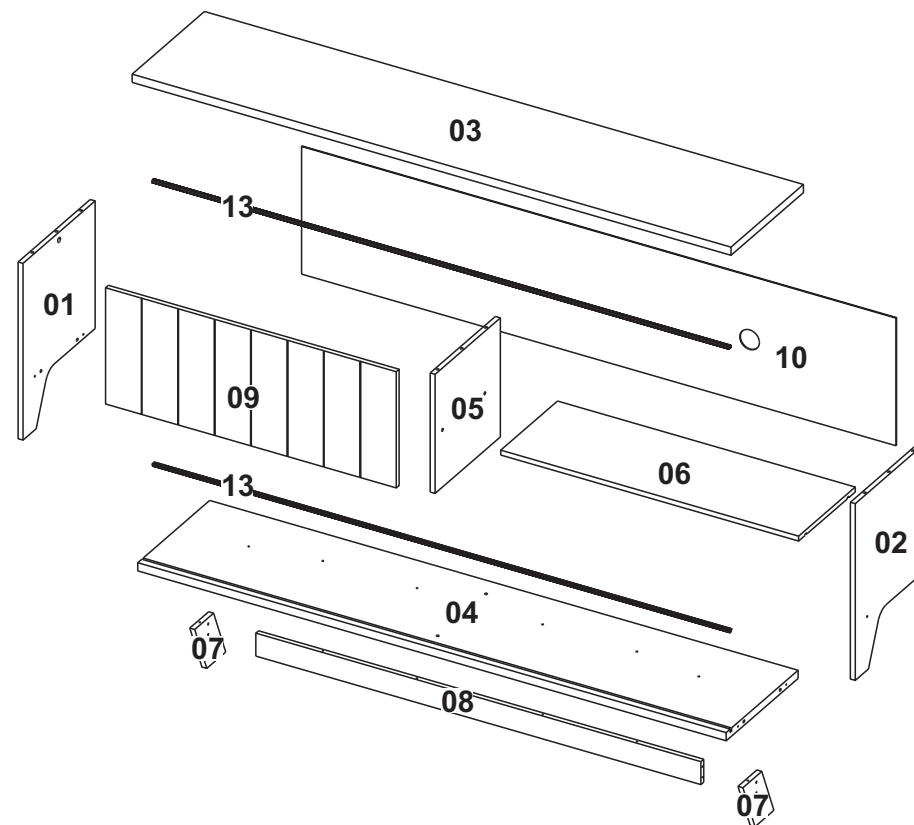
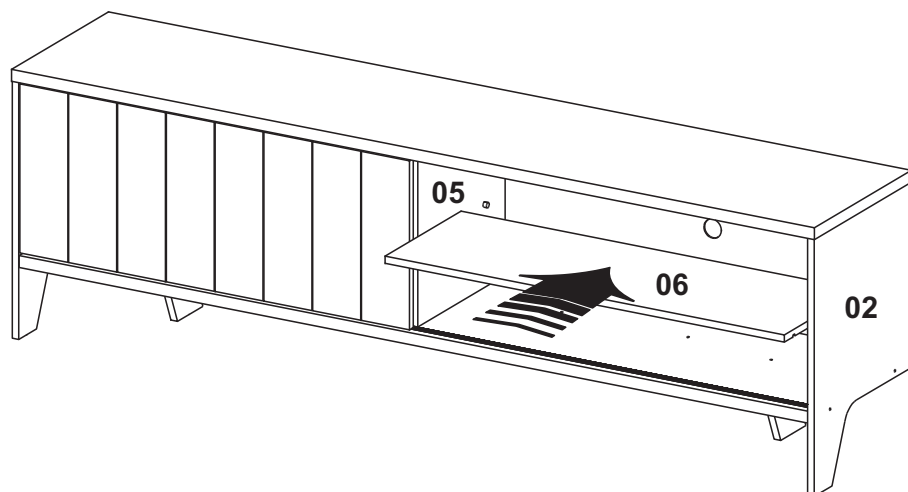

Denominação Description Denominación	Qde Qty Cad	Dimensão Dimension Dimensión
01 - Lateral Esquerda / Left Side / Lateral Izquierda	01	540x382x15
02 - Lateral Direita / Right Side / Lateral Derecha	01	540x382x15
03 - Tampo / Top / Tapa	01	1830x383x25
04 - Base / Base / Base	01	1798x381x25
05 - Divisão / Division / División	01	364x345x15
06 - Prateleira / Shelf / Estante	01	910x300x15
07 - Pé / Feet / Pata	02	203x92x15
08 - Rodapé / Skirt / Zócalo	01	1360x70x15
09 - Porta / Door / Puerta	01	355x888x15
10 - Costa / Back / Revés	01	1816x390x3
13 - Trilho / Rail / Carril	02	1764

**ETAPA DE PREPARAÇÃO DAS PEÇAS.
STAGE OF PREPARATION OF THE PIECES.
FASE DE PREPARACIÓN DE LAS PIEZAS.**

**PREPARE TODAS AS PEÇAS ANTES DE INICIAR A MONTAGEM.
PREPARE ALL THE PIECES BEFORE BEGINNING THE ASSEMBLY.
PREPARAR TODAS LAS PIEZAS ANTES DE INICIAR EL MONTAJE.**

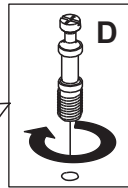

8 Passo
Step
Paso

Ajuste Interno
Internal Adjustment
Ajuste Interno

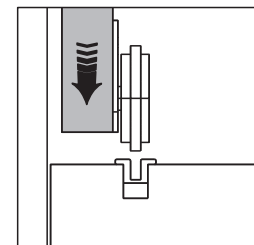
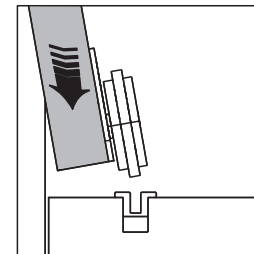
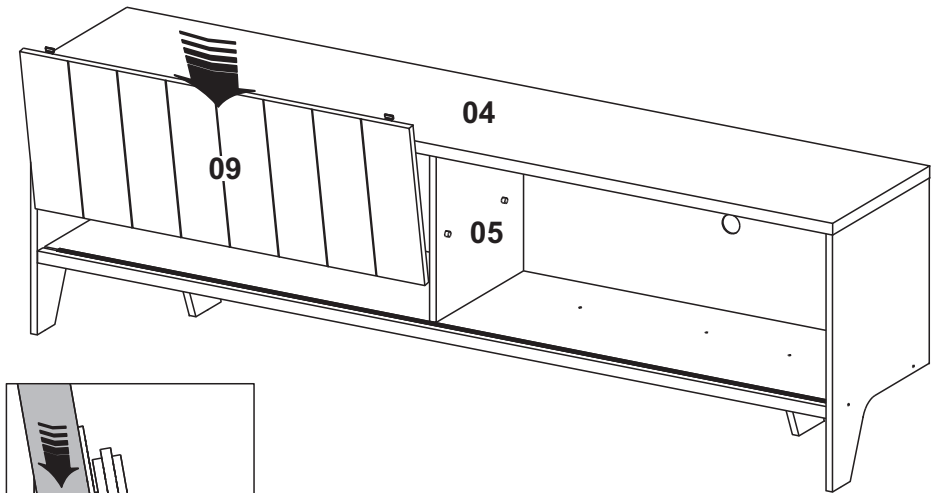
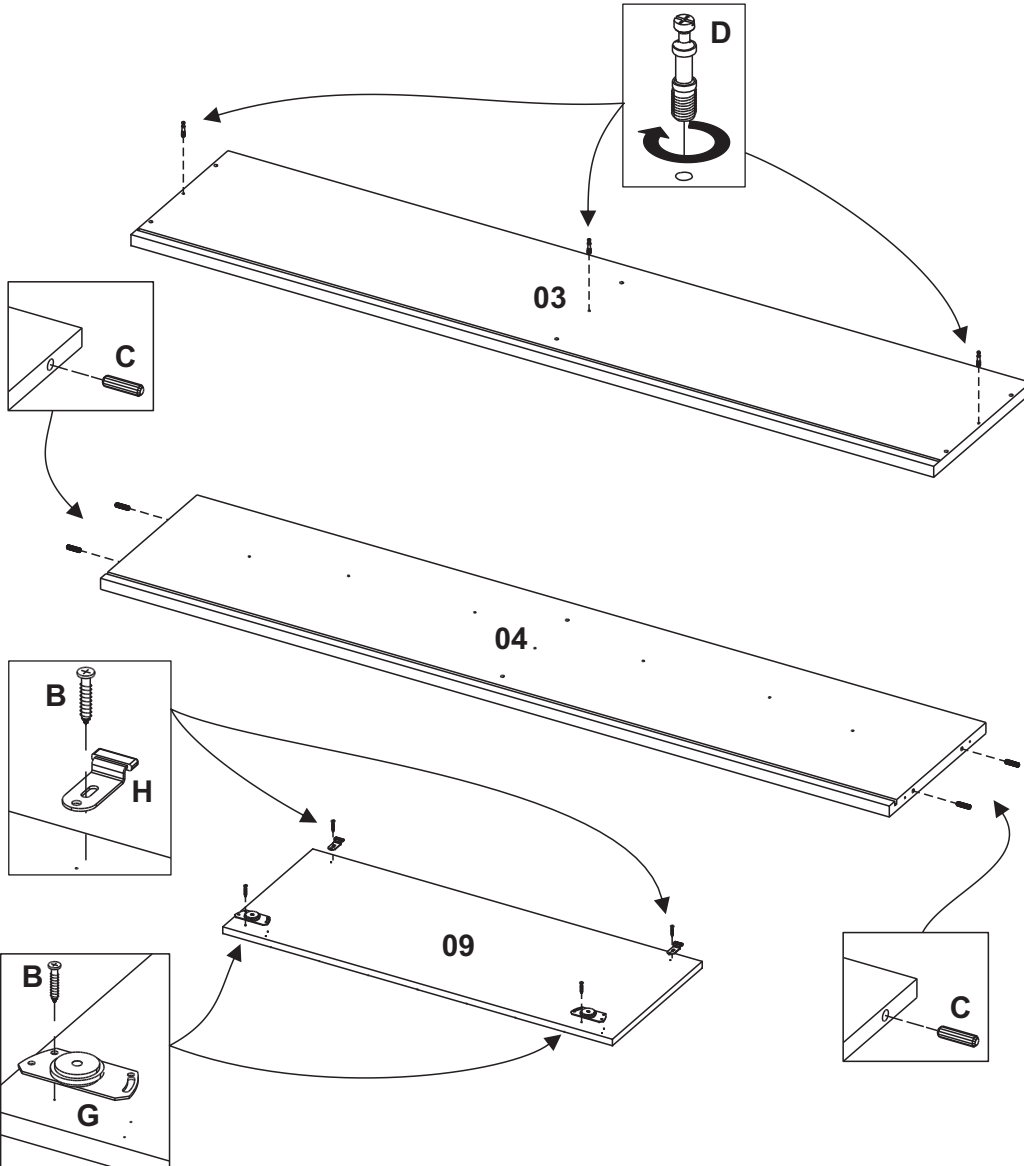
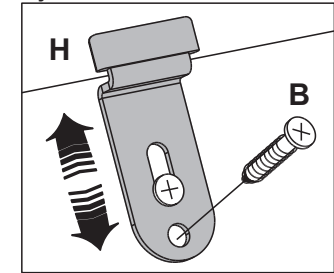

Ajuste Interno
Internal Adjustment
Ajuste Interno

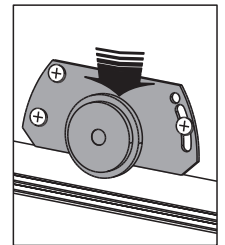
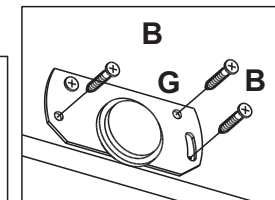
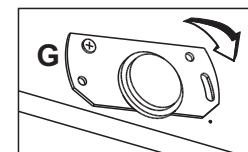

6 Passo
Step
Paso

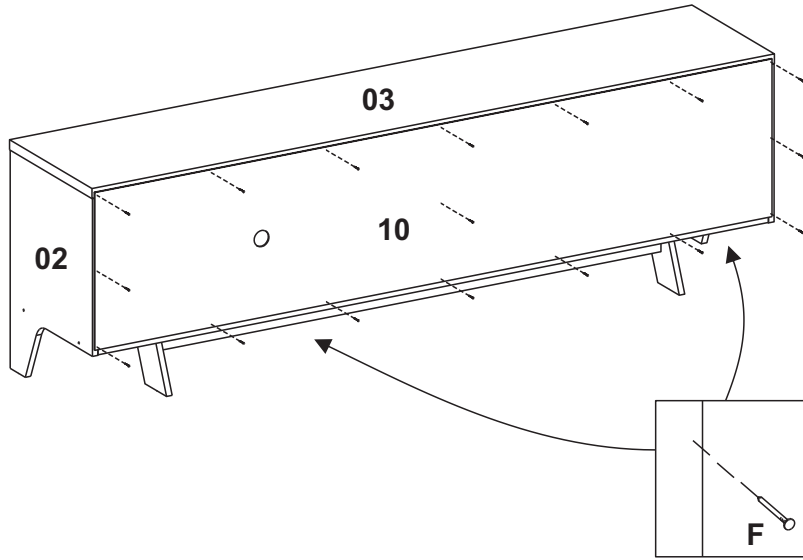

7 Passo
Step
Paso

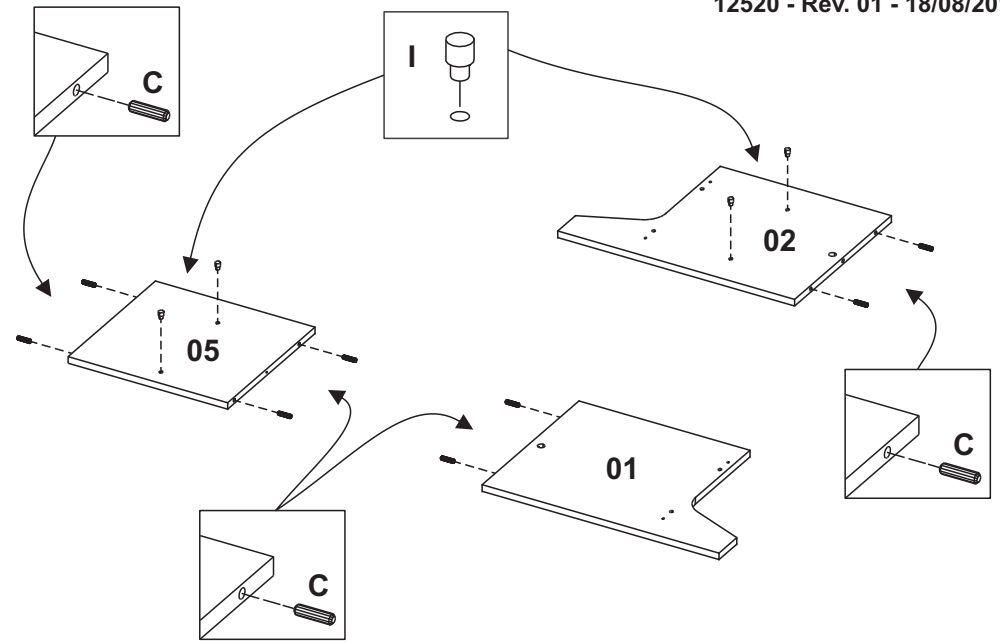
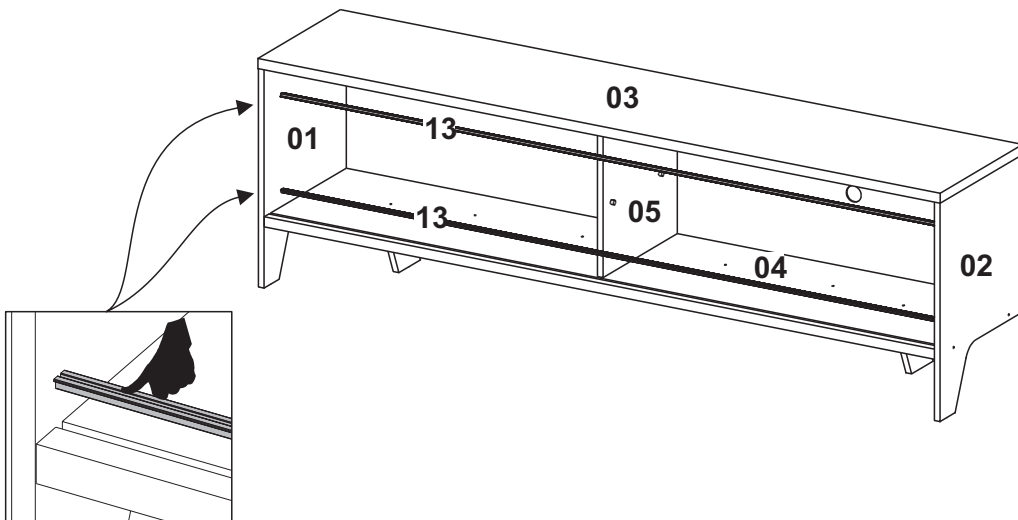

**ETAPA DE MONTAGEM.
STAGE OF ASSEMBLY.
FASE DE MONTAJE.**

1 Passo
Step
Paso

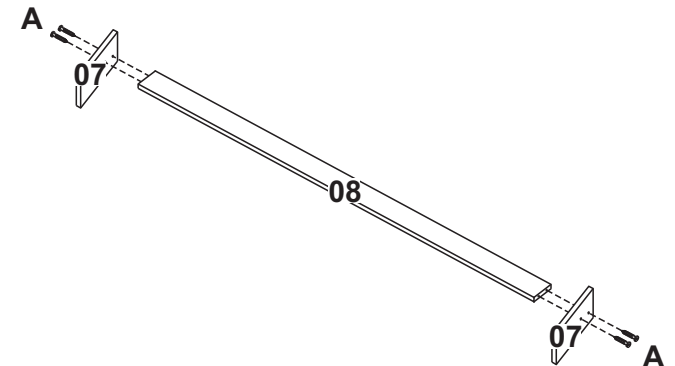

2 Passo
Step
Paso

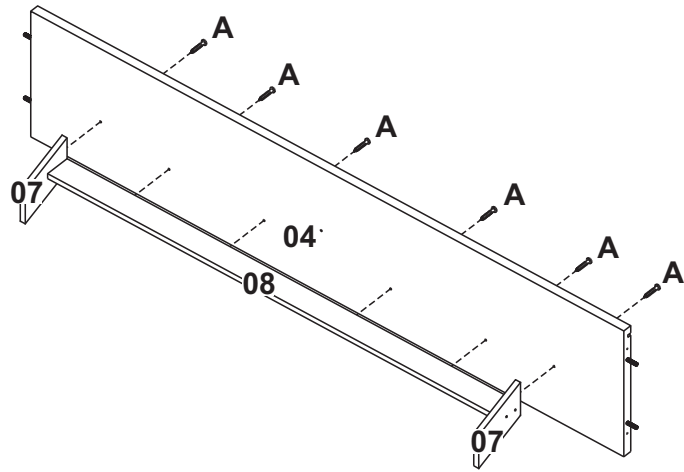

3 Passo
Step
Paso

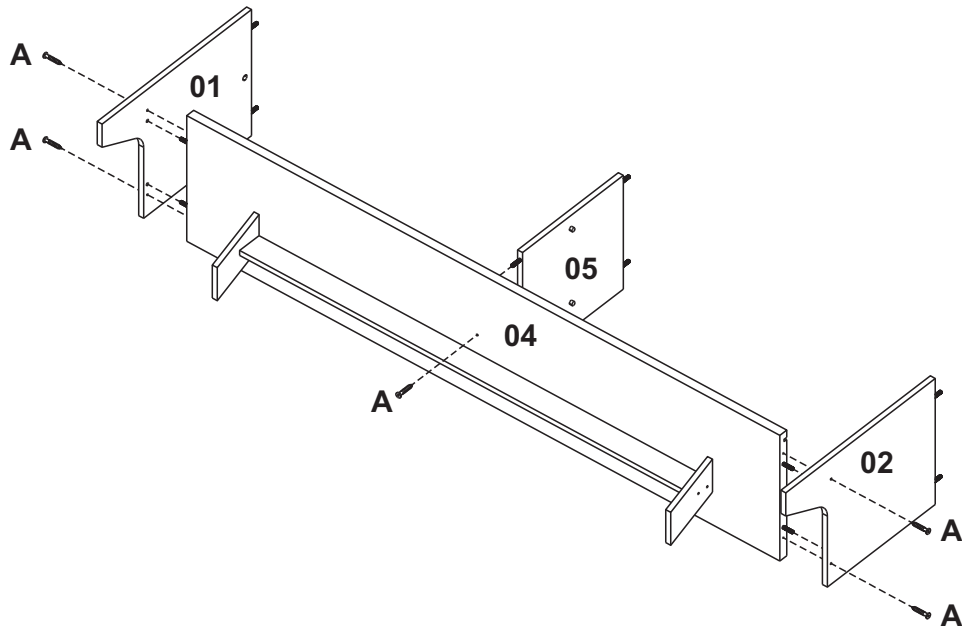

4 Passo
Step
Paso

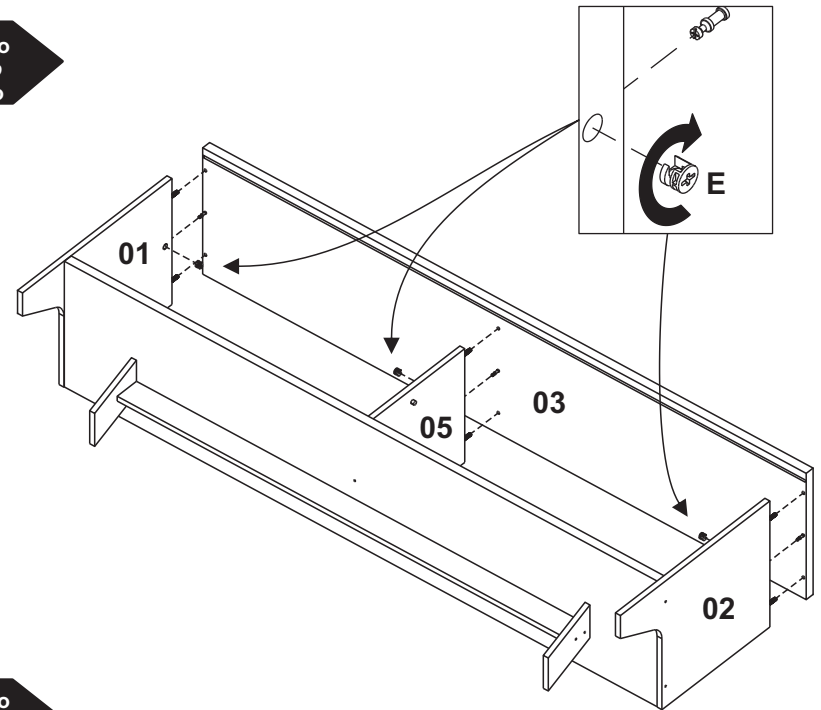

5 Passo
Step
Paso

