

LISTA DE PEÇAS/ LISTA DE PIEZAS

ITM/D179- Rev.004

Item	Caixa	Qty	Descrição/ Descripción	Medidas (mm)
01	3/6	01	Base/ Base	2670x520x15
02	3/6 e 4/6	02	Travessa Lateral Base/ Base plato de acompañamiento	490x90x15
03	4/6	02	Travessa Central Base/ Base central travessa	490x70x15
04	3/6	01	Travessa Frontal Base/ Base Travesaño delantero	2721x70x25
05	1/6	01	Lateral Esquerda/ Lateral Izquierda	2275x520x15
06	1/6	01	Divisão Esquerda/ División Izquierda	1831x520x15
07=18	3/6	01	Prateleira do Calceiro/ Estantería Calceiro	880x250x15
08	4/6	02	Prateleira Lateral/ Estante Lateral	880x450x15
09	1/6	01	Divisão Direita/ División Derecha	1831x520x15
10	2/6	01	Prateleira Inferior Gavetas/ Los cajones estante inferior	880x450x15
11	2/6	01	Tampo das Gavetas/ Tapa de los cajones	880x450x15
12=14	2/6	01	Divisória/ Tabique	445x271x15
13	2/6	01	Prateleira Central/ Estante central	880x450x15
14=12	2/6	01	Divisória/ Tabique	445x271x15
15	4/6	01	Chão do Maleiro/ Piso del Armario de Equipaje	2670x520x15
16	2/6	02	Ripa do Maleiro/ Listón del Armario de Equipaje	414x73x15
17	1/6	01	Lateral Direita/ Lateral Derecha	2275x520x15
18=07	3/6	01	Prateleira do Calceiro/ Estantería Calceiro	880x250x15
19	3/6	01	Tampo/ Tapa	2700x545x15
20	3/6	02	Moldura Lateral/ Cornija Lateral	545x50x15
21	3/6	01	Fundo Superior/ Fondo Superior	2695x436x3
22	5/6	04	Fundo/ Fondo	1853x445x3
23	4/6	02	Fundo Respiro/ Fondo con Resperación	1853x445x3
24	3/6	01	Moldura Frontal/ Cornija Frontal	2732x50x15
25	2/6	04	Ripa Lateral/ lado Ripa	860x80x25
26	5/6 e 6/6	06	Porta/ Puerta	2265x443x15
27	2/6	01	Frente de Gaveta com Chave/ Frente del Cajón con Clave	822x106x15
28	2/6	02	Lado de Gaveta Estreito/ Lado de Cajón Estrecho	400x90x15
29=36	3/6	01	Fundo de Gaveta/ Fondo del Cajón	786x411x3
30	2/6	01	Ripa de Trás Estreita/ Listón Trasero Estrecha	805x90x15
31	3/6	02	Divisória Maior/ Tabique Mayor	775x60x9
32	2/6	02	Divisória Menor/ Tabique Menor	400x60x9
33	2/6	05	Frente de Gaveta/ Frente del Cajón	822x145x15
34	3/6	05	Vidro Fumê/ Vidrio ahumado	672x100x3
35	1/6 e 2/6	10	Lado de Gaveta/ Lado del cajón	400x122x15
36=29	3/6	05	Fundo de Gaveta recortado/ Fondo del Cajón recortado	786x411x3
37	2/6 e 4/6	05	Ripa de Trás/ Listón Trasero	805x122x15

LISTA DE FERRAGENS

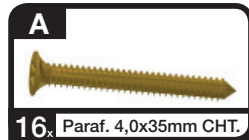

23. Paraf. 4,0x30mm FLA.	13. Paraf. 4,0x25mm CHT.	16. Paraf. 4,0x25mm FLA.	36. Paraf. 3,5x40mm CHT.	18. Paraf. 3,5x25mm FLA.	70. Paraf. 3,5x14mm FLA.
116. Paraf. 3,5x12mm CHT.	12. Paraf. 3,0x16mm CHT.	12. Prego 12x12 Anelado	210. Prego 10x10	58. Fixador de fundos	112. Cavilha 8x25mm
15. Cantoneira plástica	12. Cantoneira suporte triangular	16. Porca sextavada	16. Parafuso minifix	01. Conector de haste dupla	18. Tambor minifix
02. Respiro de roupeiro	06. Suporte cabideiro	03. Cab. Alumínio 872mm	03. Perfil "H" 1838mm	24. Calço metal 5mm	24. Dobradiça metal 26mm
06. Corrediça telescópica	06. Puxador vilage pequeno	06. Puxador Decore 768mm	01. Kit fechadura	01. Batente metal	02. Giz de correção
12. Etiqueta resinada Henn	16. Adesivo tapa parafuso 17mm	38. Adesivo tapa parafuso 10mm	03. Sachê de cola	11. Sapata retangular alta	20. Suporte p/ Fixação Vidro



www.henn.com.br
henn@henn.com.br
55 49 3674 3500
Mondai/SC - Brasil

INSTRUÇÃO DE MONTAGEM
INSTRUCCIONES DE MONTAJE
Roupeiro Studio 06 Portas / Armario Studio 06 Puertas

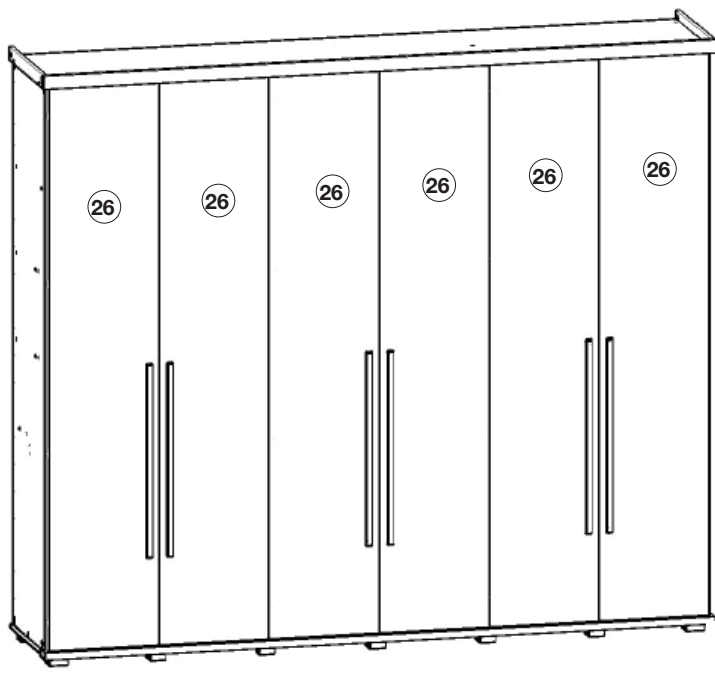

AVISO
Para limpeza de seu móvel, use uma flanela seca ou umedecida, e não utilize produtos químicos que possam danificar seu produto.

SISTEMA DE MONTAGEM
O sistema de montagem dos produtos, funciona de acordo com a ordem crescente dos números indicados no desenho. Ex: 01, 02, 03, 04... até a conclusão da montagem.

ADVERTENCIA
Para limpieza de su móvil, use una flanela seca o húmeda, y no utilice productos químicos que puedan dañar su producto.

SISTEMA DE MONTAJE
El sistema de montaje de los productos funciona de acuerdo con el orden creciente de los números indicados en el dibujo. Ej.: 01, 02, 03, 04... hasta la conclusión del montaje.

- D179-05 - Branco HP
- D179-10 - Branco
- D179-83 - Moka
- D179-94 - Rústico
- D179-101 - Cafê

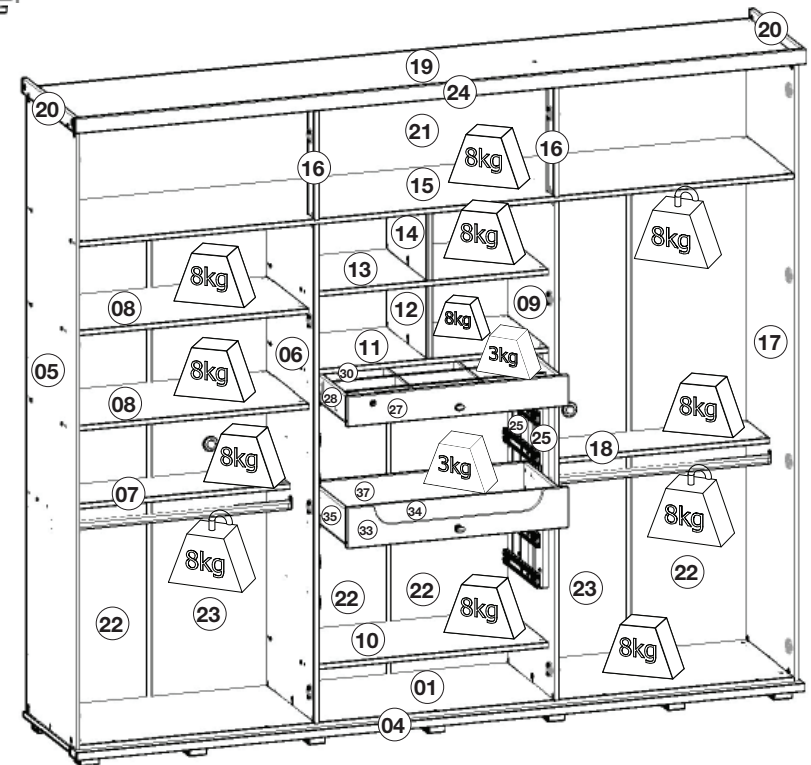

Pesos máximos recomendados com carga uniformemente distribuídas.
Peso máximo recomendado con la carga distribuida uniformemente.

REQUISITOS PARA MONTAGEM
REQUISITOS PARA LA ASAMBLEA

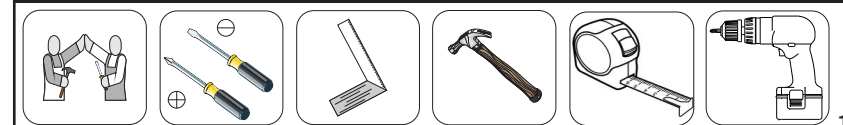

Imagens meramente ilustrativas / Imágenes meramente ilustrativas

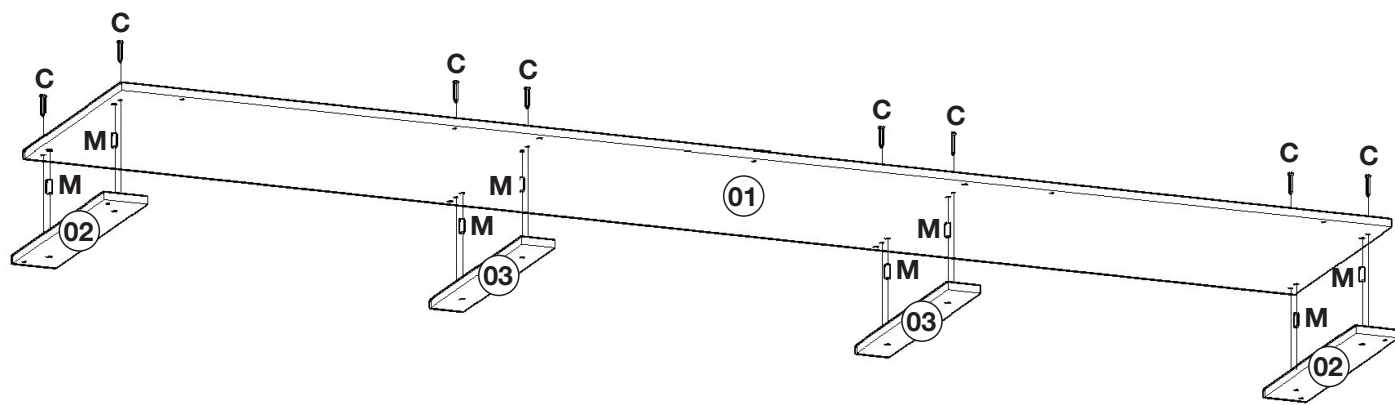

Para a colocação da travessa frontal base (04) alinhar a mesma com as travessas laterais base (02).

Para la colocación del travesaño delantero base (04) para alinearlo con las carril lateral base (02).

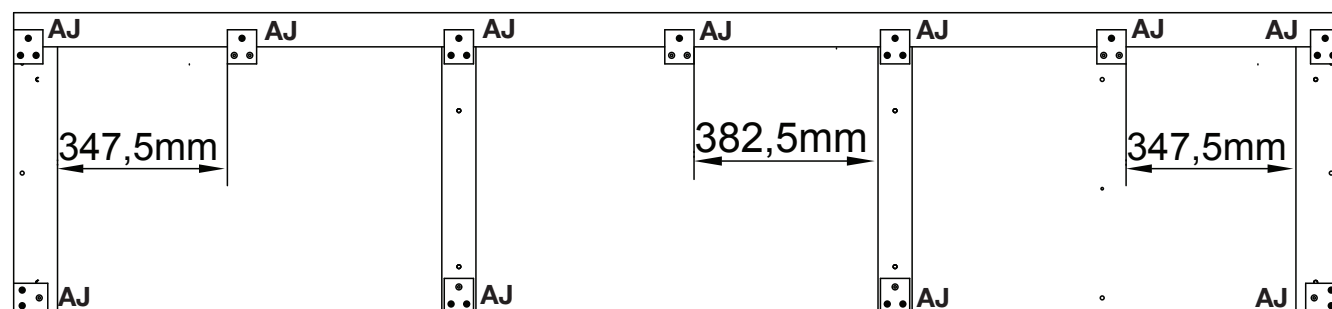
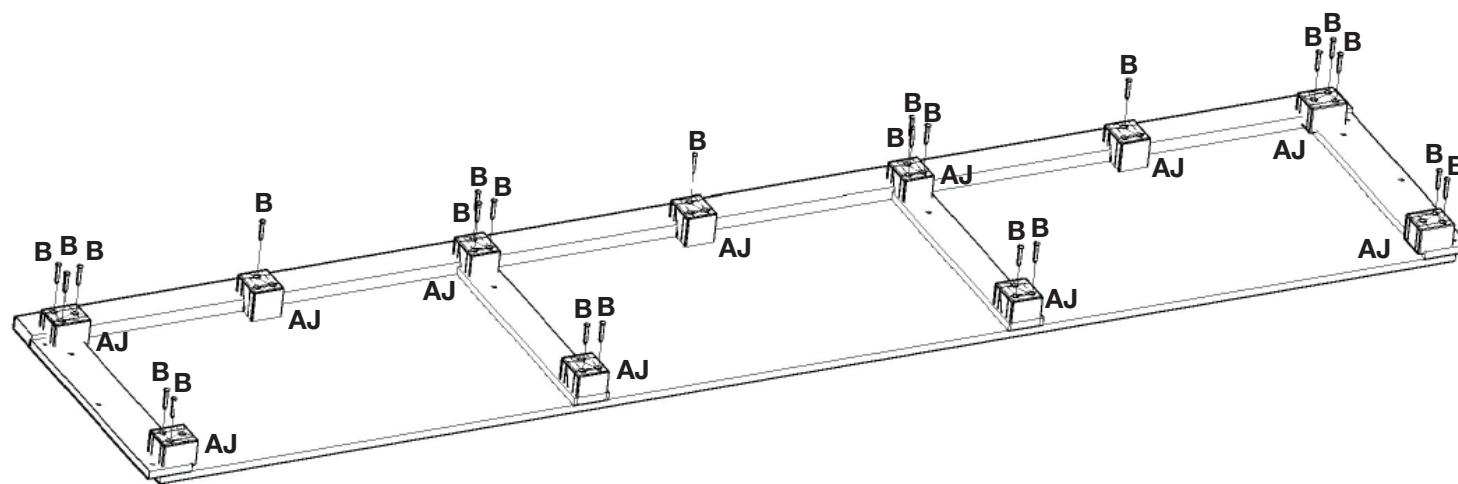
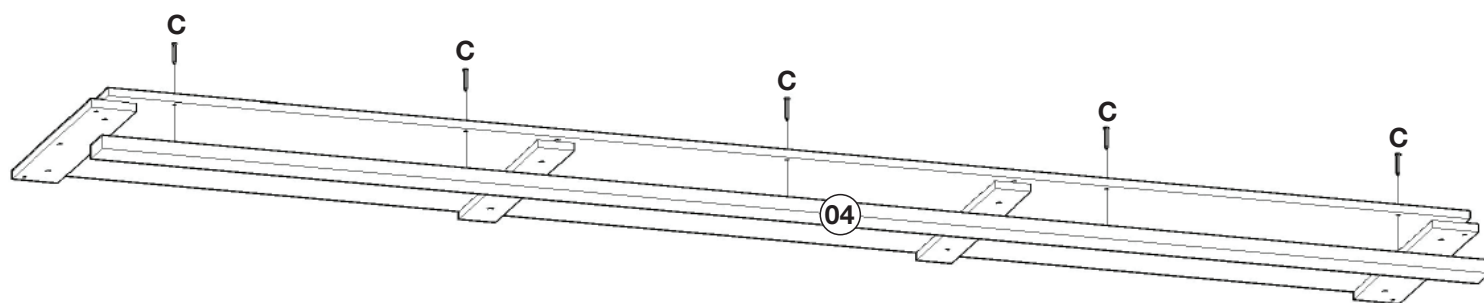

Montagem da gaveta 05x.

Montaje cajón 05x.

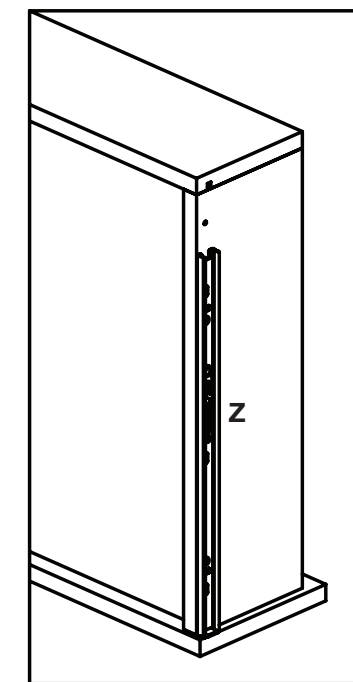
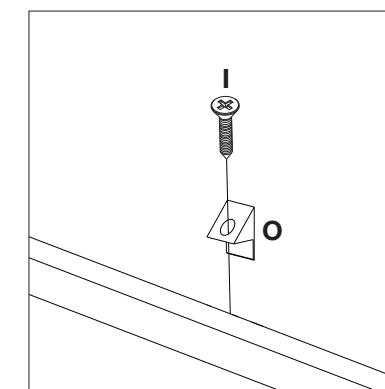
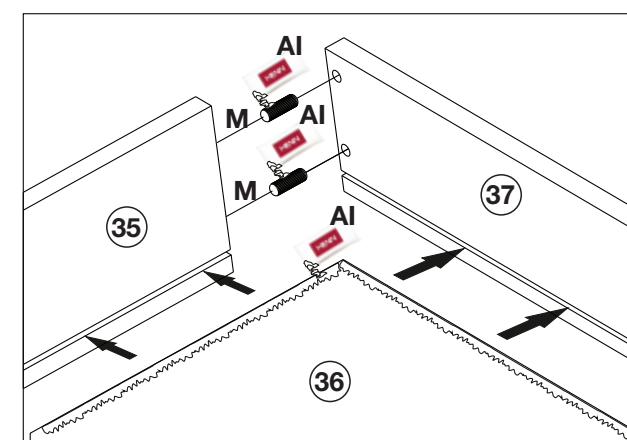
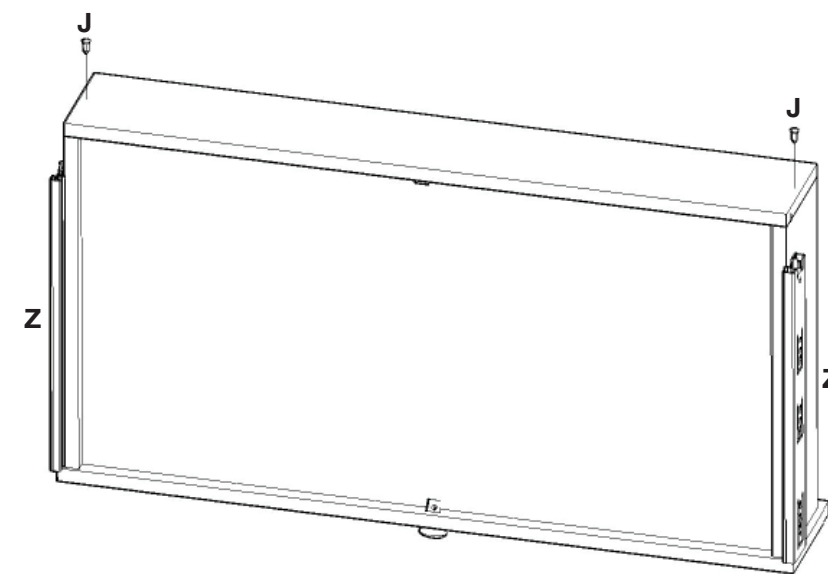
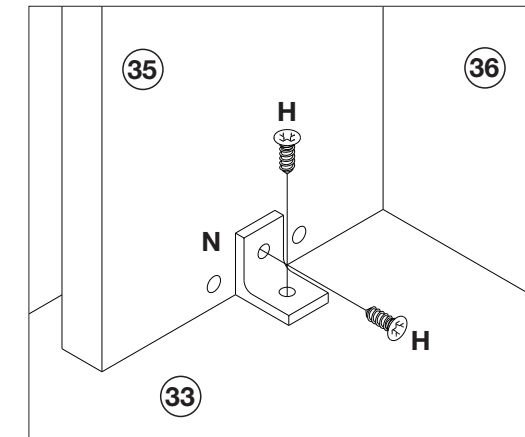
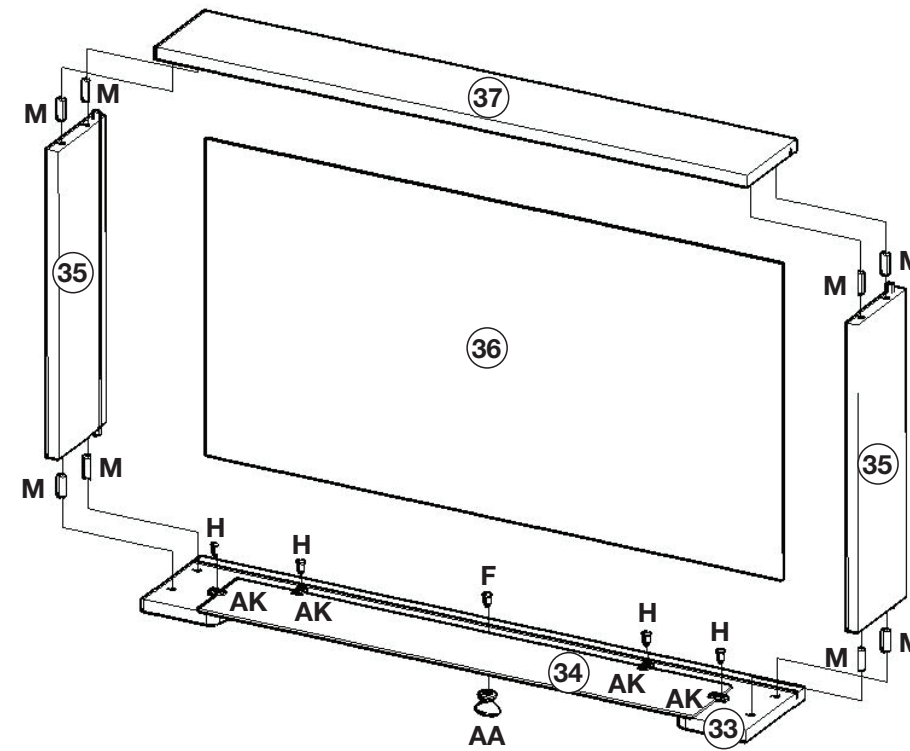

Utilize o sachê de cola (AI) nas cavilhas (M) e nos frisos de gaveta.

Utilice la bolsita de pegamento (AI) los pernos (M) y cajón de friso.

A corrediça (Z) deverá ser alinhada com a parte de baixo do lado de gaveta (35).

la diapositiva (Z) debe estar alineado con la parte inferior del cajón (35).

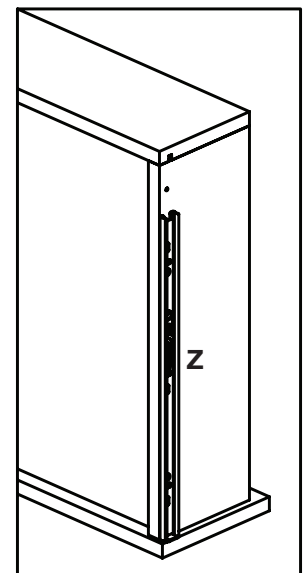
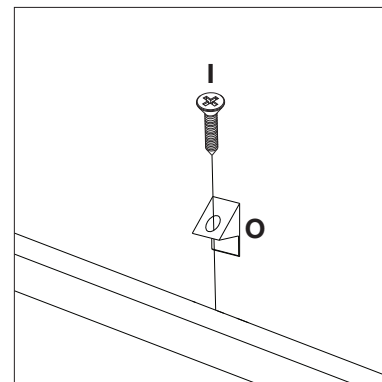
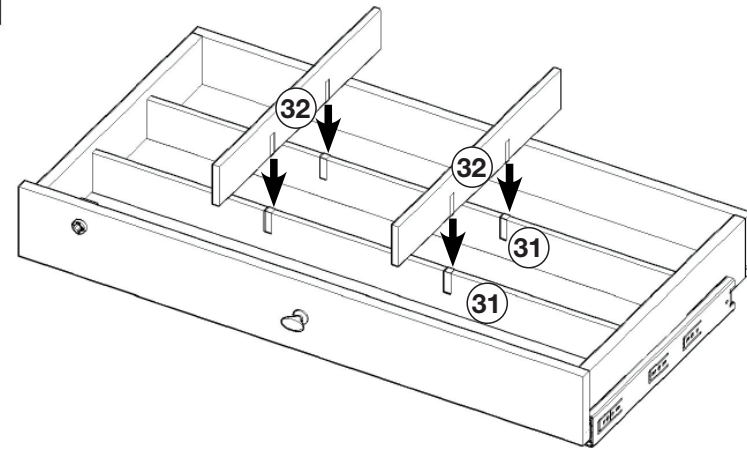
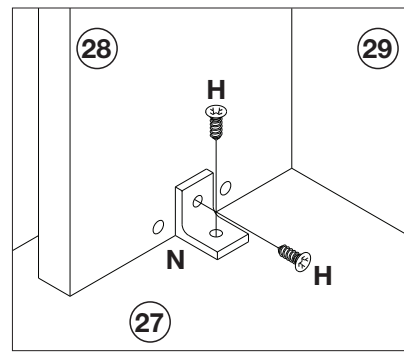
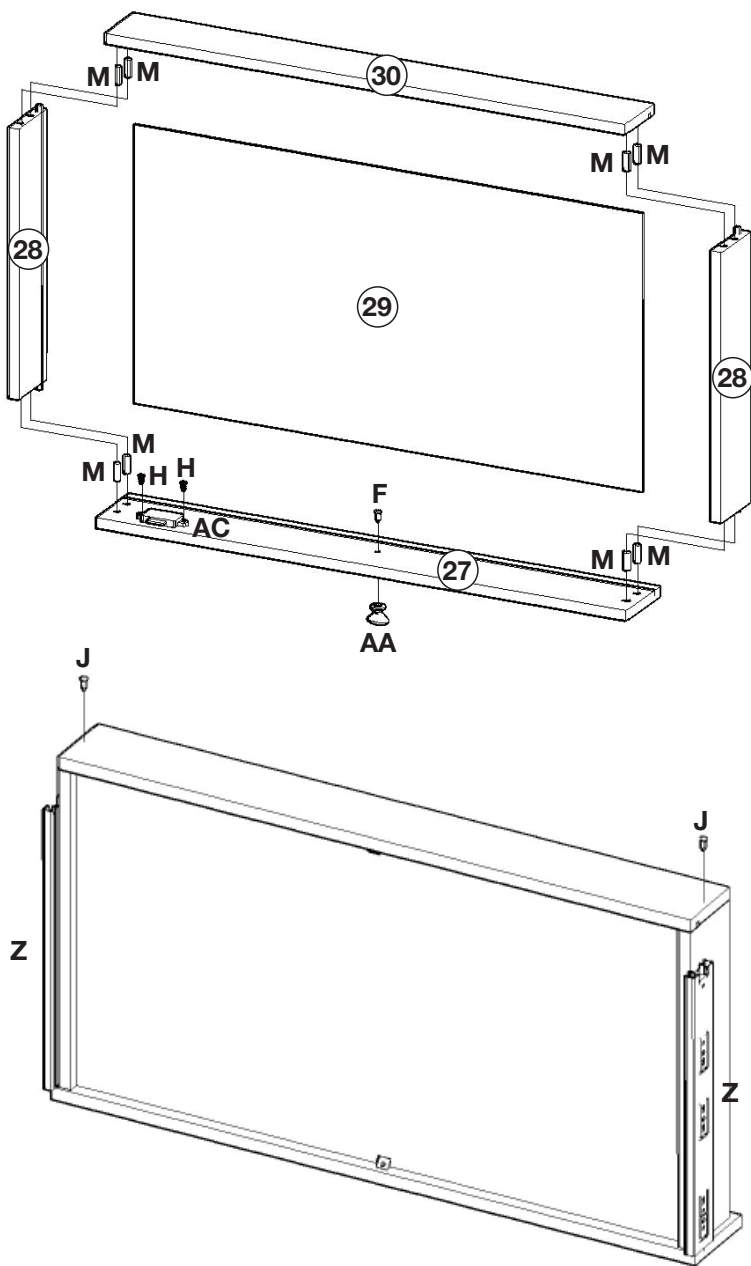

Utilize o sachê de cola (AI) nas cavilhas (M) e nos frisos de gaveta.

Utilice la bolsita de pegamento (AI) los pernos (M) y cajón de friso.

A corrediça (Z) deverá ser alinhada com a parte de baixo do lado de gaveta (28).

la diapositiva (Z) debe estar alineado con la parte inferior del cajón (28).

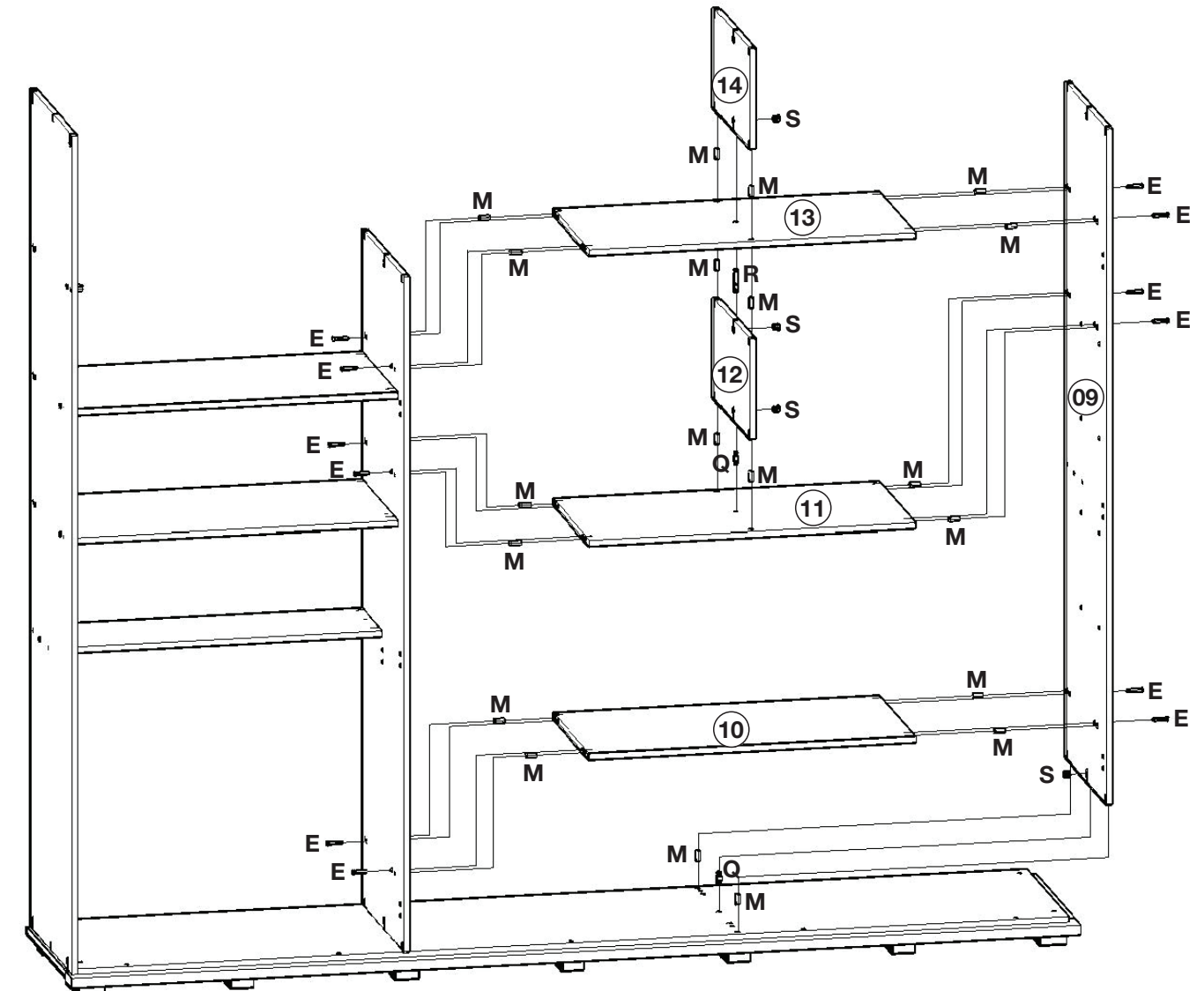
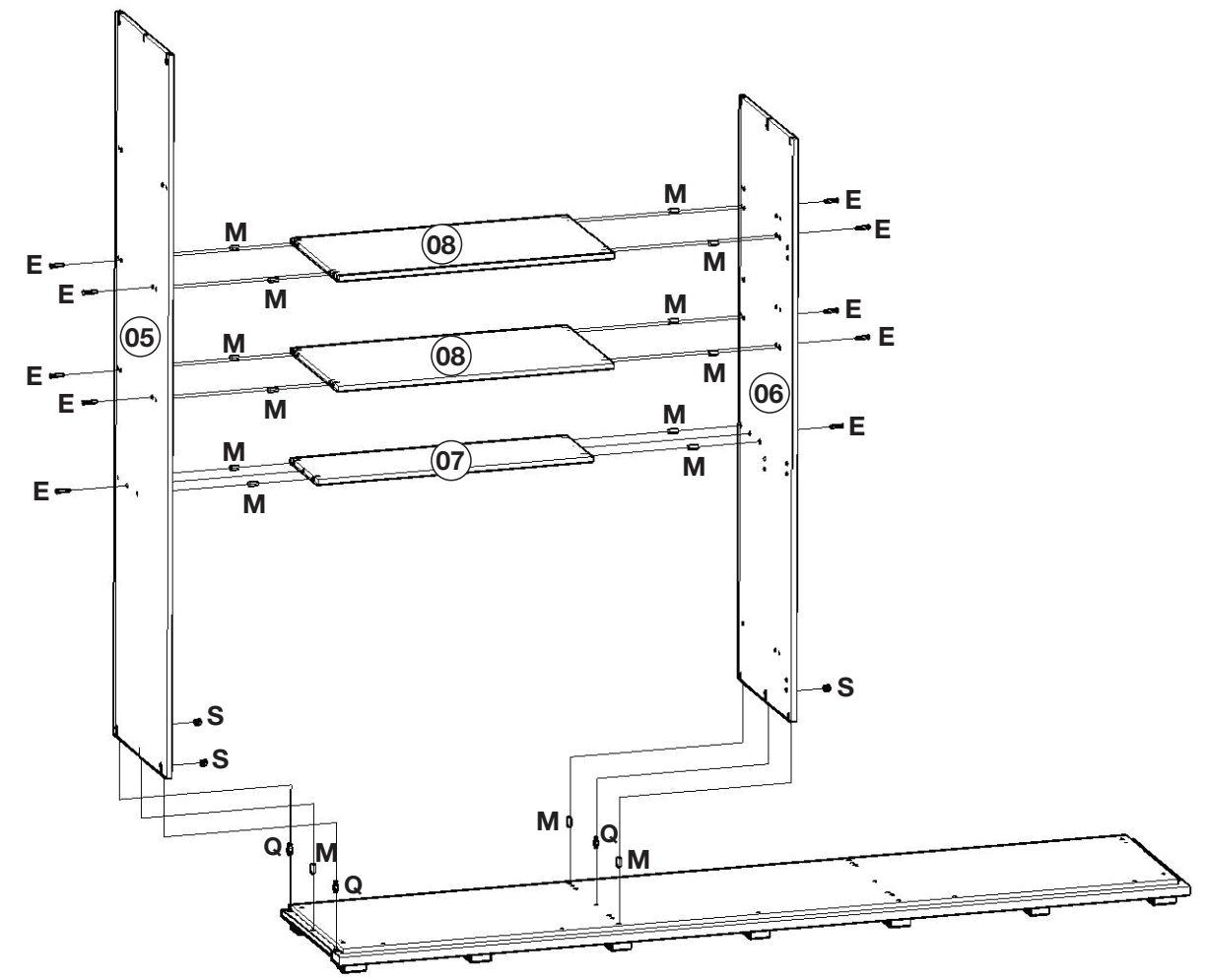

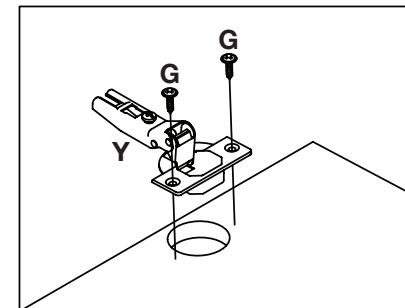
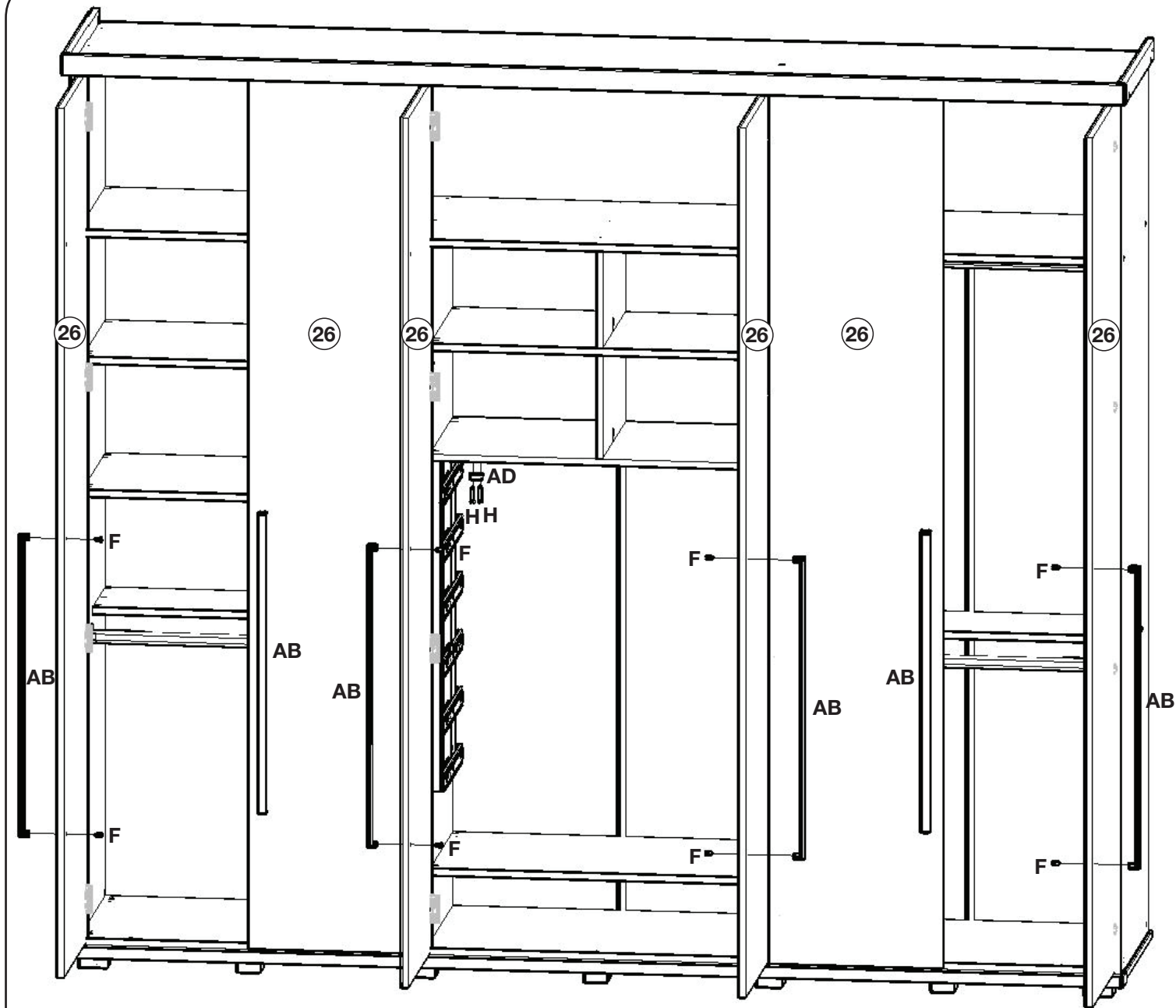
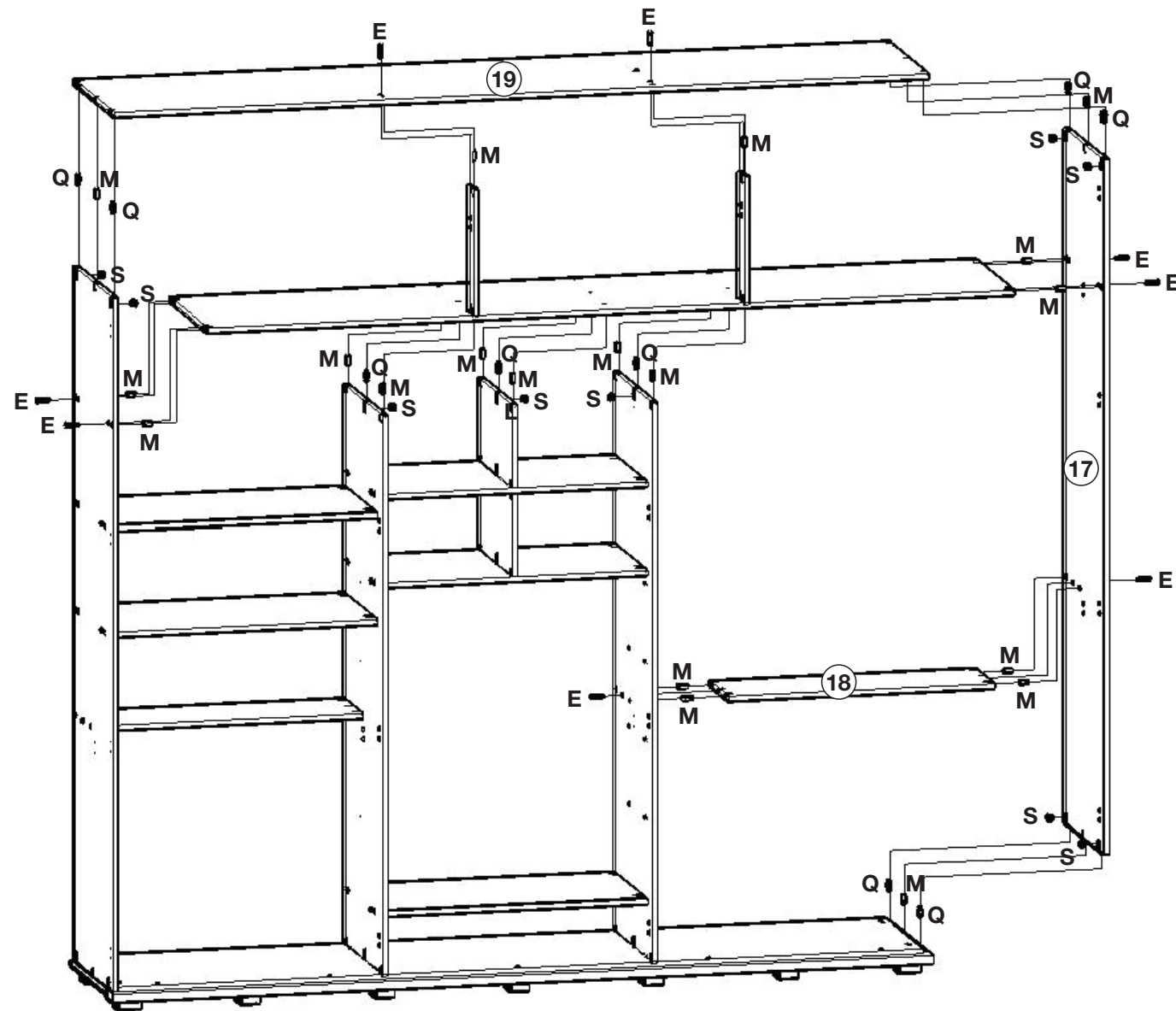
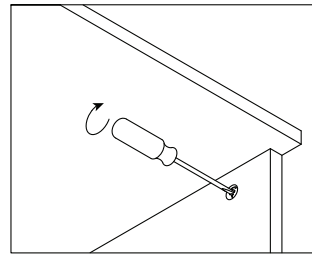
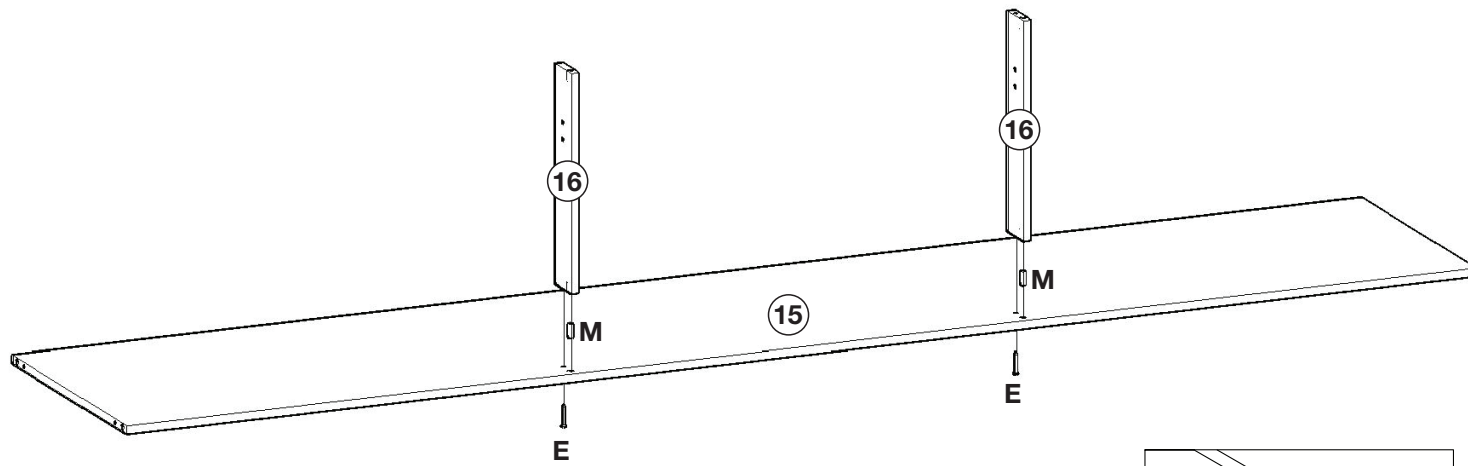

Colocação da dobradiça (Y) nas portas (26).

Colocación de la bisagra (Y) las puertas (26).

Encaixe da dobradiça (Y) com o calço (X).

Fit bisagra (Y) con la cuña (X).

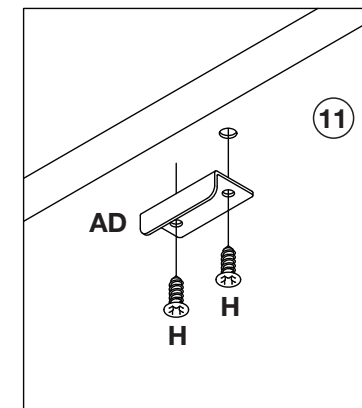
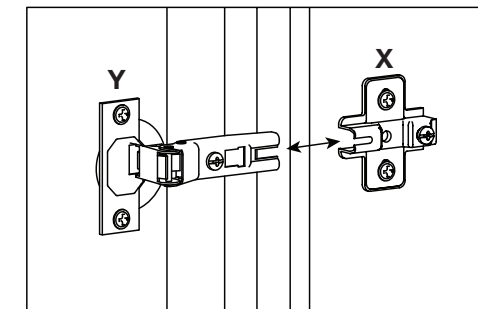

11

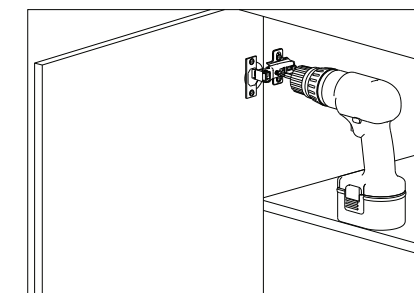

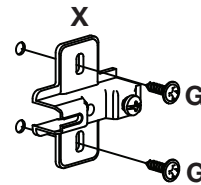
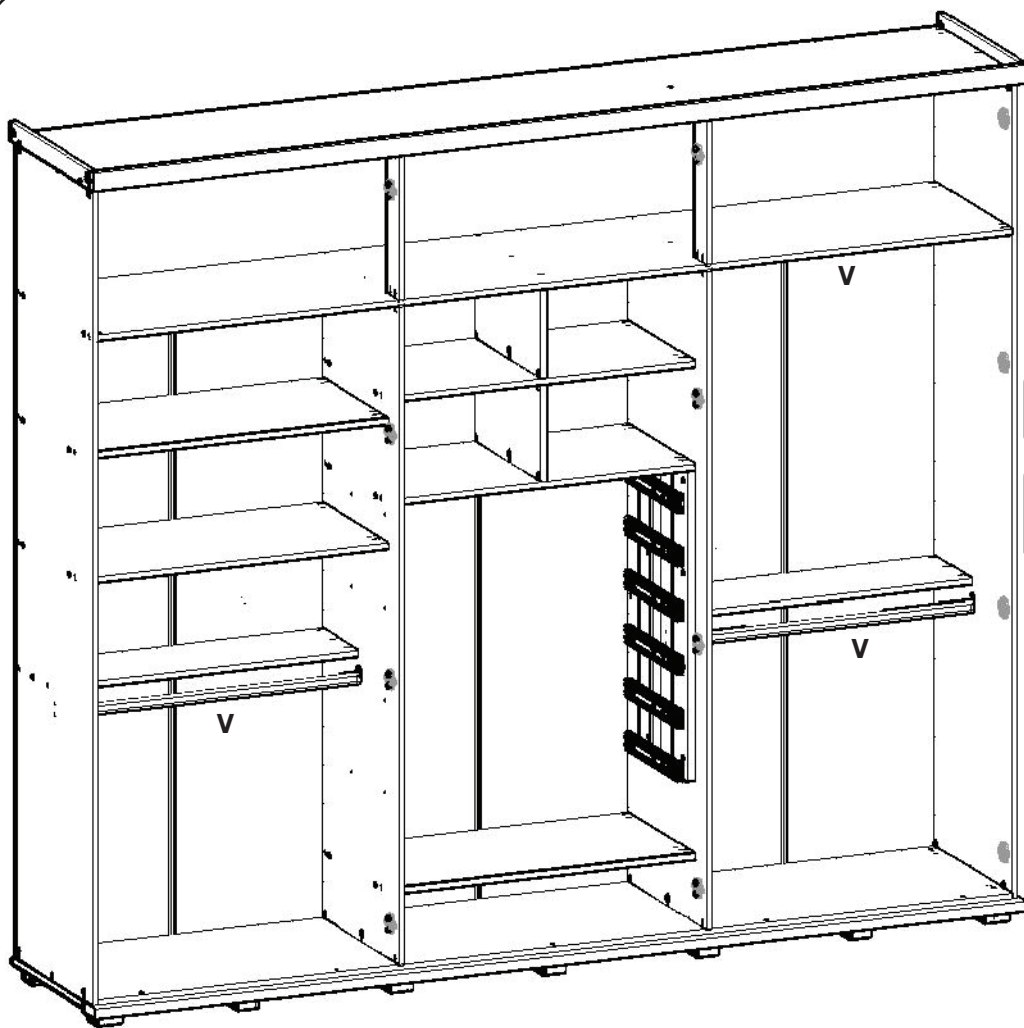

Colocação dos calços (X) na lateral esquerda (05) e na lateral direita (17).

Colocación de la cuña (T) en el lateral izquierda (05) y en el lateral derecha (17).

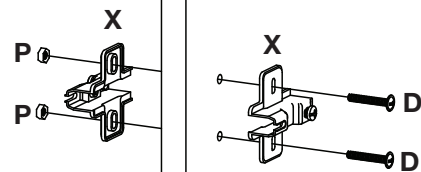

Colocação dos calços (X) na Divisão esquerda (06), na Divisão direita (09) e Ripa do Maleiro (16).

La colocación de las cuñas (X) en la división de la izquierda (06), la división de la derecha (09) y portaequipajes tablas de madera (16).

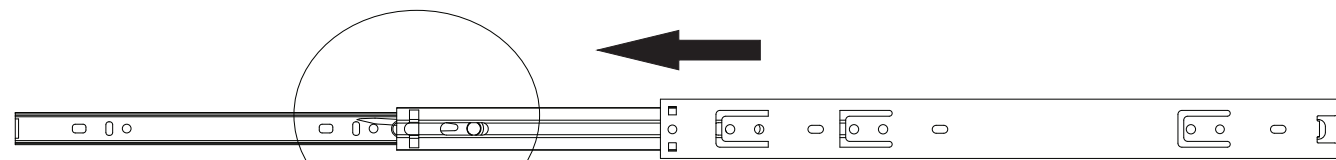
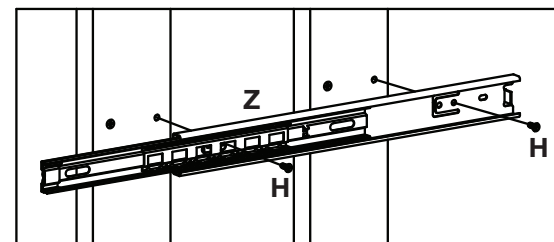

Para a desmontagem da correia siga a instrução ao lado.

Para el desmontaje seguimiento de diapositivas la instrucción siguiente a.

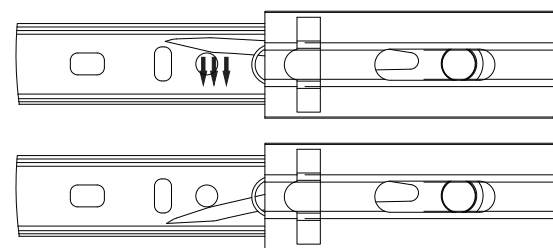

Fixar as correias nessas furações
Fijar las diapositivas de estos agujeros

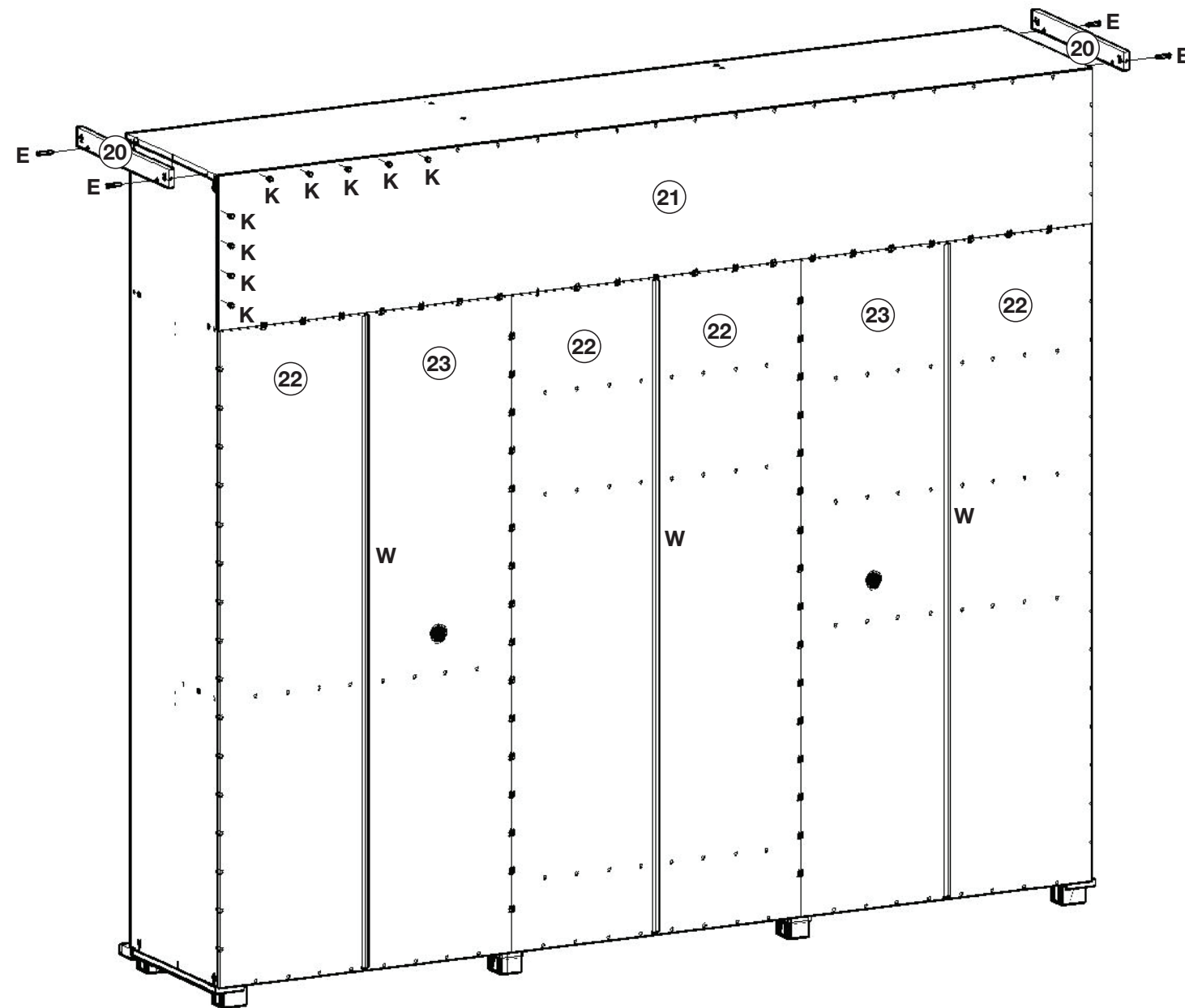

Colocar os pregos (K) a uma distância de 100mm de um para outro.

Coloque los clavos (K) a una distancia de 100 mm uno de otro.

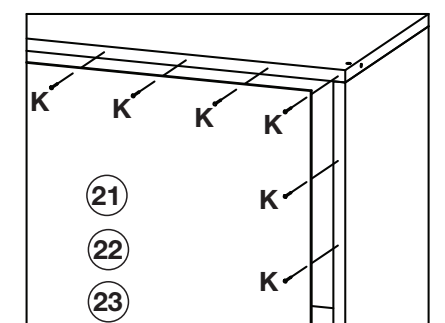
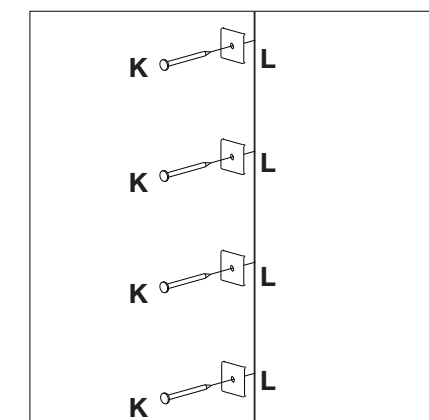
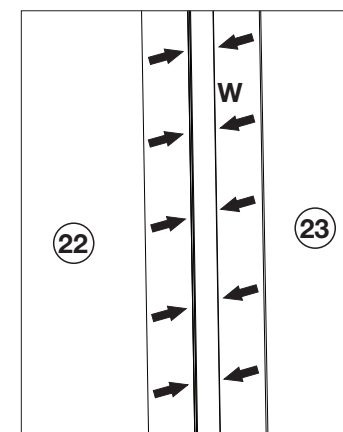

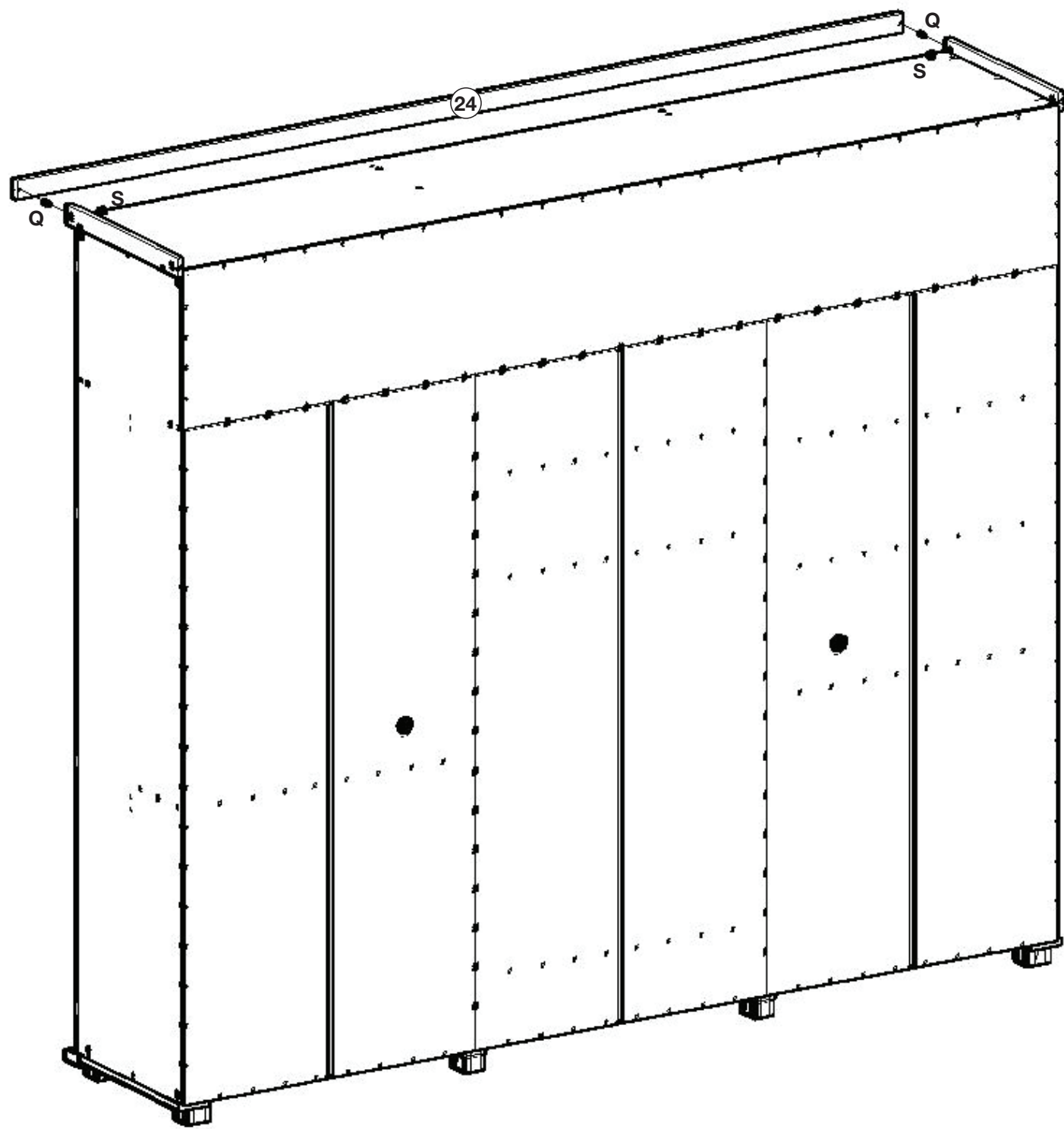

Coloção das cantoneiras (N)
na moldura frontal (24).

La colocación de los ángulos (N)
el marco delantero (24)

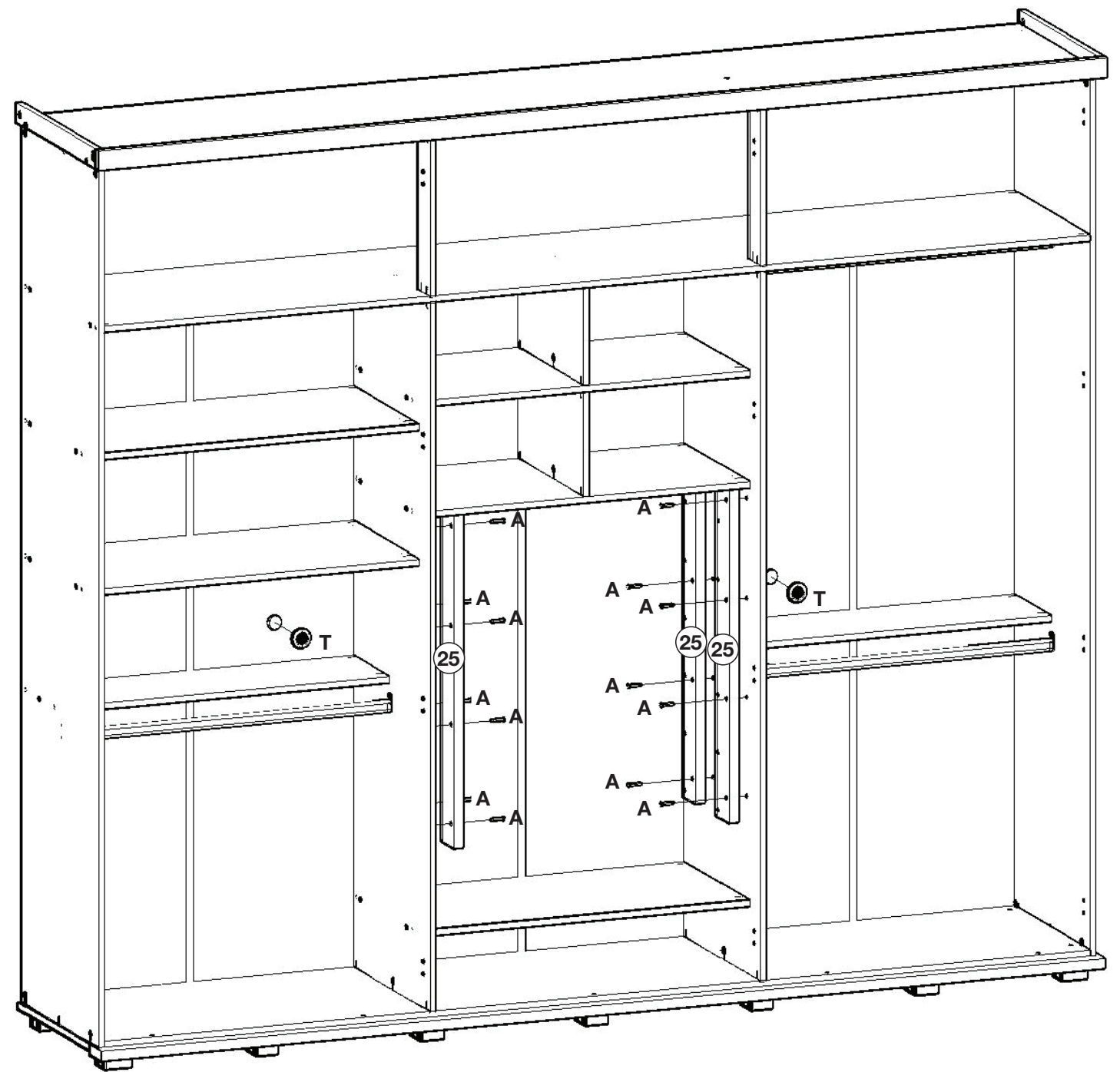
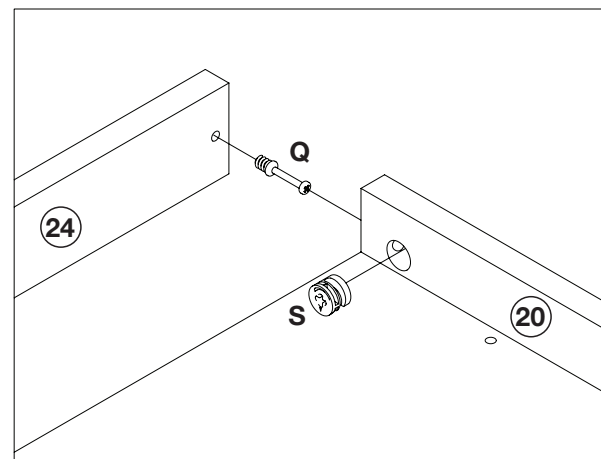
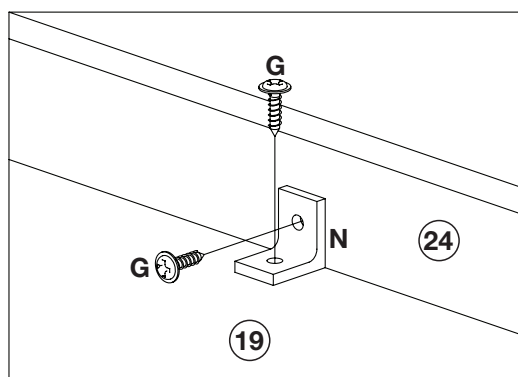

Coloção Adesivo tapa parafuso 17mm (AG).

Colocación tapa de tornillo de 17 mm (AG).

Coloção dos suporte cabideiros (U).

La colocación de la rejilla de soporte (U)

