

MANUAL DE MONTAGEM
Assembly instructions / Instrucciones de armado

KIT ESCRITÓRIO TERESINA

Teresina Office kit
Kit oficina Teresina

Código 170537 | Revisão 00

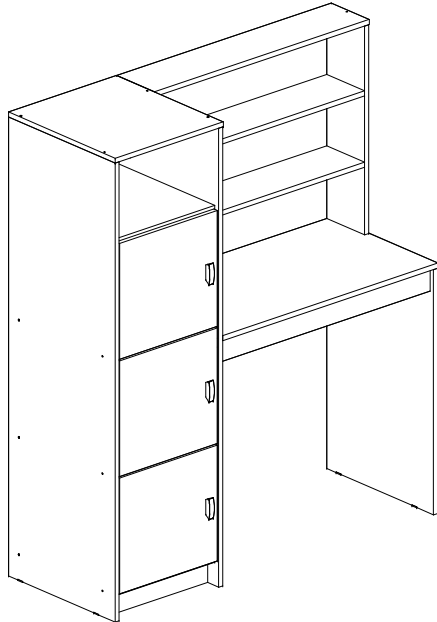

PESO MÁXIMO SUPORTADO PELAS PEÇAS, SENDO ESTE DISTRIBUÍDO UNIFORMEMENTE.

Maximum weight supported by parts, being this evenly distributed.
Peso máximo soportado por las partes, siendo esta distribuido uniformemente.

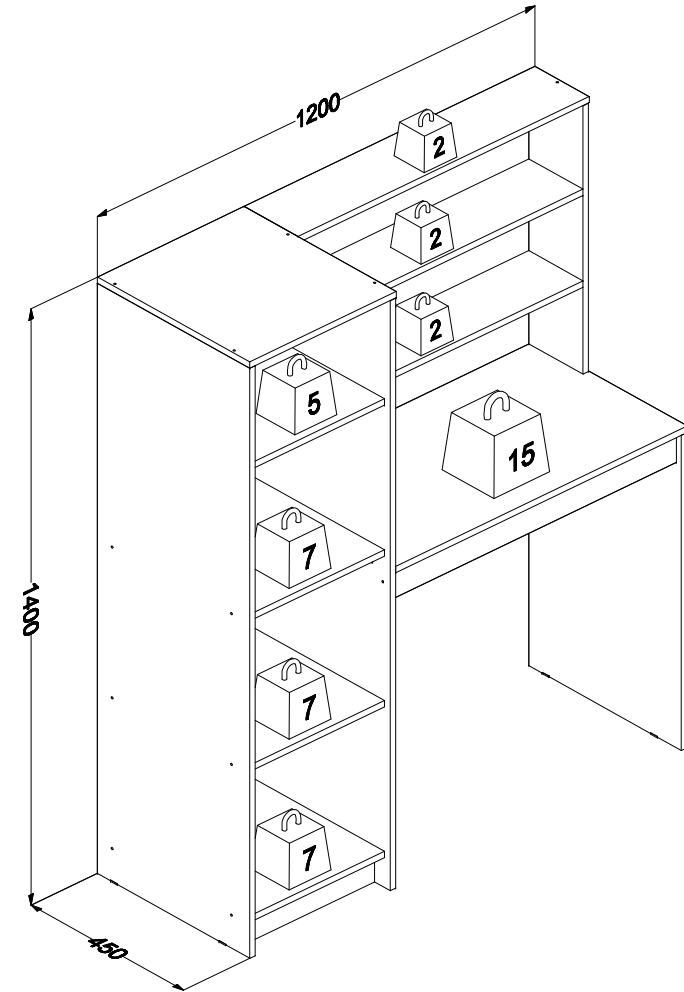

Você vai precisar de/ You will need / Usted necesitará

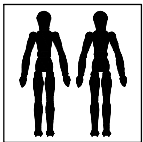

2 Pessoas
2 People
2 Personas

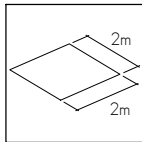

Espaço recomendado para montagem
Recommended space for assemble
Espacio recomendado para el armado

Ferramentas não inclusas
Tools not included / Herramientas no incluidas

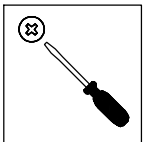

Chave Philips
Screwdriver
Destornillador cruz



Martelo
Hammer
Martillo











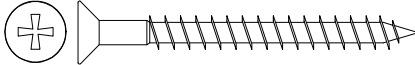

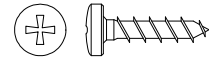
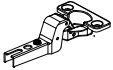
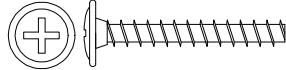
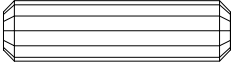
* PESO EM KG/ Weight in Kg/ Peso en Kg
DIMENSÕES EM MM/ Dimensions in mm/ Dimensiones en mm

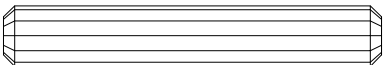
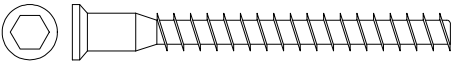
IDENTIFICAÇÃO DOS ACESSÓRIOS/ IDENTIFICATION OF ACCESSORIES/ IDENTIFICACIÓN DE ACCESORIOS

NOTAS: A separação dos acessórios antes de iniciar a montagem facilitará a mesma. Os parafusos e cavilhas estão na escala real. Em caso de dúvida na identificação, coloque o acessório sobre a imagem.

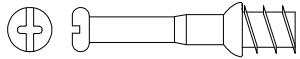
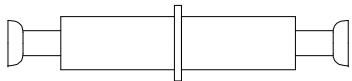
NOTES: The separation of the accessories before you start the assembly will facilitate the same. The screws and dowels are in real scale. In case of doubts about the identification, place the accessory on the image.

NOTAS: La separación de los accesorios antes de comenzar el armado facilitará el mismo. Los tornillos y taquetes son en escala real. En caso de dudas sobre la identificación, coloque el accesorio en la imagen.

C1		Garra de metal Metal claw Garra metal	-	11	O		Parafuso chato Flat head screw Tornillo de cabeza plana	4,5x45 mm	01
D5		Calço dobradiça Hinge shim Bisagra de calce	-	06	S		Parafuso panela Pan head screw Tornillo de pan	3,5x14 mm	24
D6		Dobradiça super alta Metal hinge super high Bisagra alta	26mm	06	T		Parafuso flangeado Flanged head screw Tornillo de cabeza flangeada	3,5x25 mm	06
E		Cavilha Wooden Dowel Pin	8x30 mm	45	Z		Tapa furo plástico Plastic hole plugs Tapones plásticos	8 mm	03
E7		Sapata Small plastic foot Pie plástico	15 mm	06					
F		Cavilha Wooden Dowel Taquete	8x50 mm	02					
G		Parafuso estrutural Structural screw Tornillo estrutural	5,0x50 mm	29					
H		Chave allen Allen key Llave Allen	-	02					
I		Tampa parafuso estrutural Structural screw cover Tapa tornillo estrutural	-	29					
i9		Puxador Handle Tirador	-	03					
J		Haste minifix simples Simple minifix screw Tornillo minifix simple	-	02					
K8		Haste minifix dupla Double minifix screw Tornillo minifix doble	45 mm	01					
L		Tambor minifix Drum lock Tambor minifix	12 mm	04					
M		Tapa furo adesivo Bore patch adhesive Tapones adhesivo	-	03					
N		Prego Nail Clavo	10 x10	63					

IDENTIFICAÇÃO DAS PEÇAS/ PARTS IDENTIFICATION/ IDENTIFICACIÓN DE LAS PIEZAS

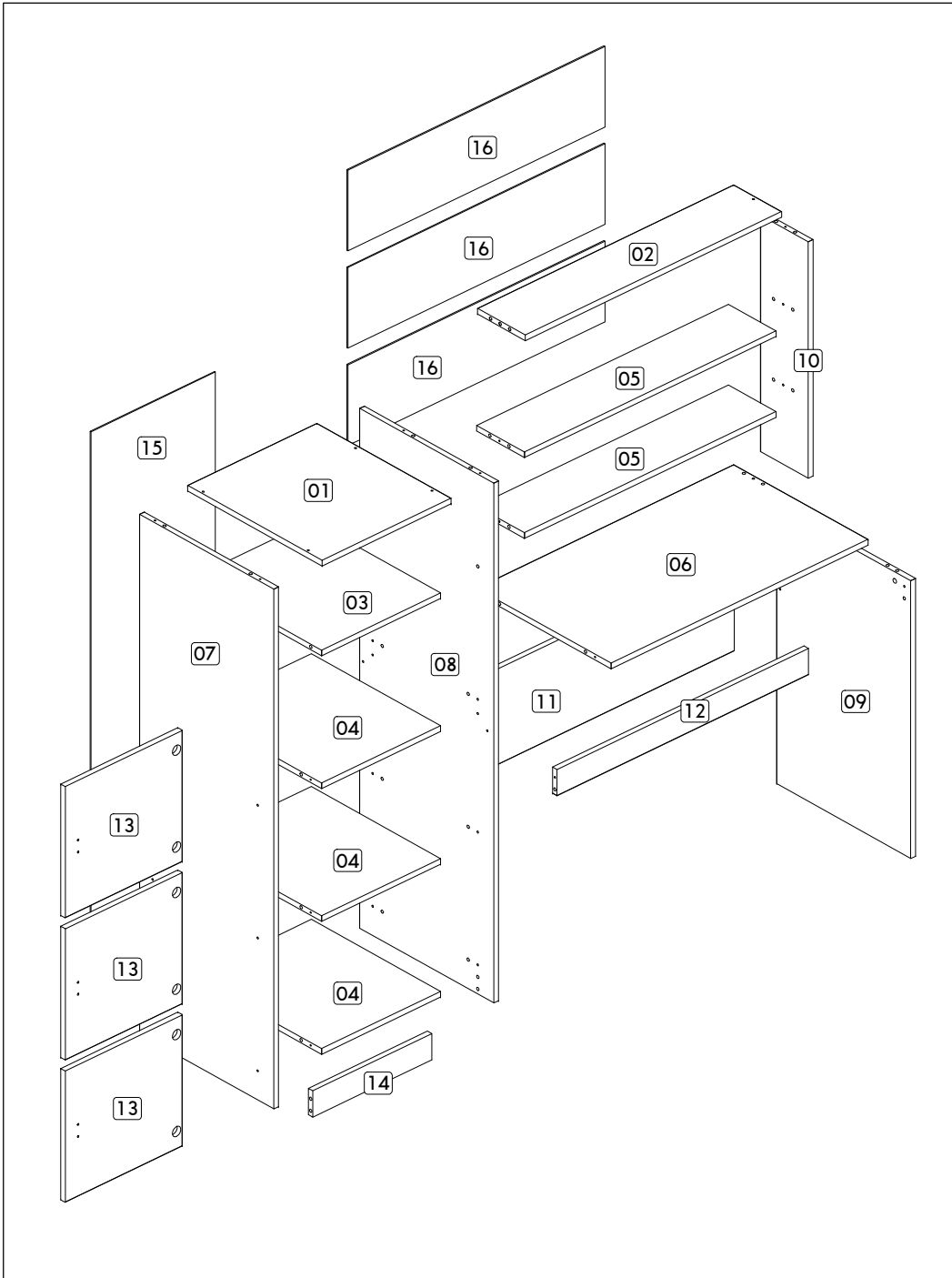

Nº	DESCRIÇÃO - DESCRIPTION - DESCRIPCIÓN	MEDIDAS-MEASURES - MEDIDAS (mm)	QTD.
01	Base superior esquerda - Upper left base - Base superior izquierda	402 x 450 x 15	01
02	Base superior direita - Upper right base - Base superior derecha	798 x 160 x 15	01
03	Prateleira esquerda superior - Upper left shelf - Repisa izquierda superior	370 x 433 x 15	01
04	Prateleira esquerda - Left shelf - Repisa izquierda	370 x 433 x 15	03
05	Prateleira direita - Right shelf - Repisa derecha	783 x 160 x 15	02
06	Tampo - Top - Tapa	800 x 450 x 15	01
07	Lateral esquerda - Left side - Lateral izquierda	1385 x 450 x 15	01
08	Divisão - Division - División	1385 x 450 x 15	01
09	Lateral direita inferior - Right bottom side - Lateral derecha inferior	740 x 450 x 15	01
10	Lateral direita superior - Right upper side - Lateral derecha superior	630 x 160 x 15	01
11	Costa 15mm - Back - Fondo	783 x 255 x 15	01
12	Travessa frontal - Front tray - Travesía frontal	783 x 70 x 15	01
13	Porta - Door - Puerta	364 x 350 x 15	03
14	Rodapé - Footer - Zocalo	370 x 70 x 15	01
15	Costa esquerda - Left backboard - Fondo izquierdo	1320 x 387 x 3	01
16	Costa direita - Right backboard - Fondo derecho	800 x 215 x 3	03

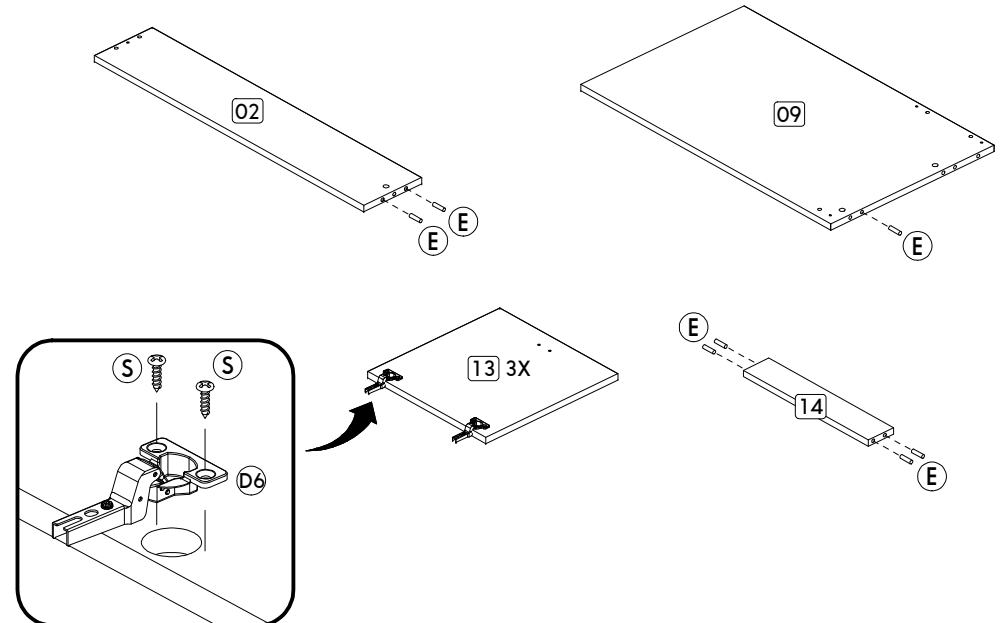
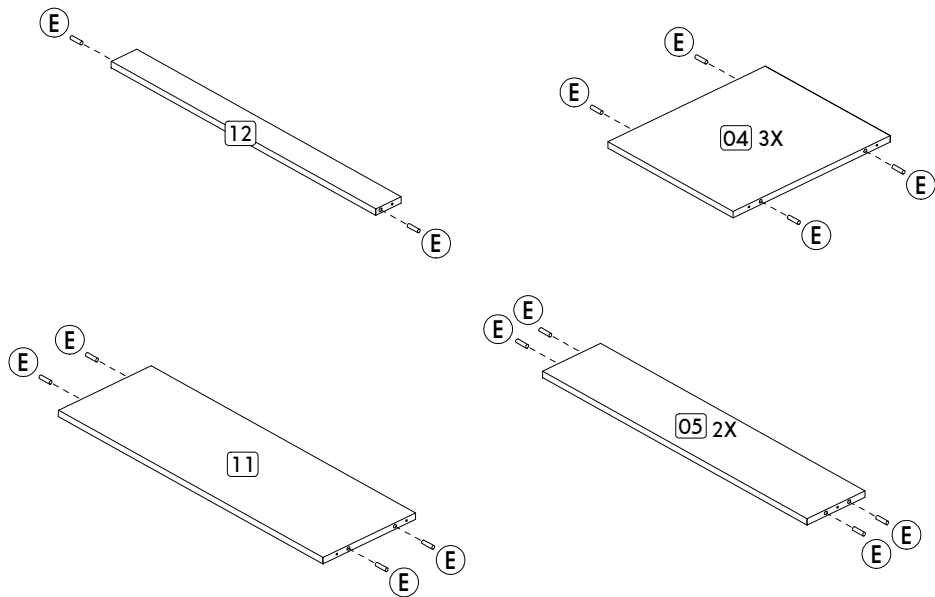
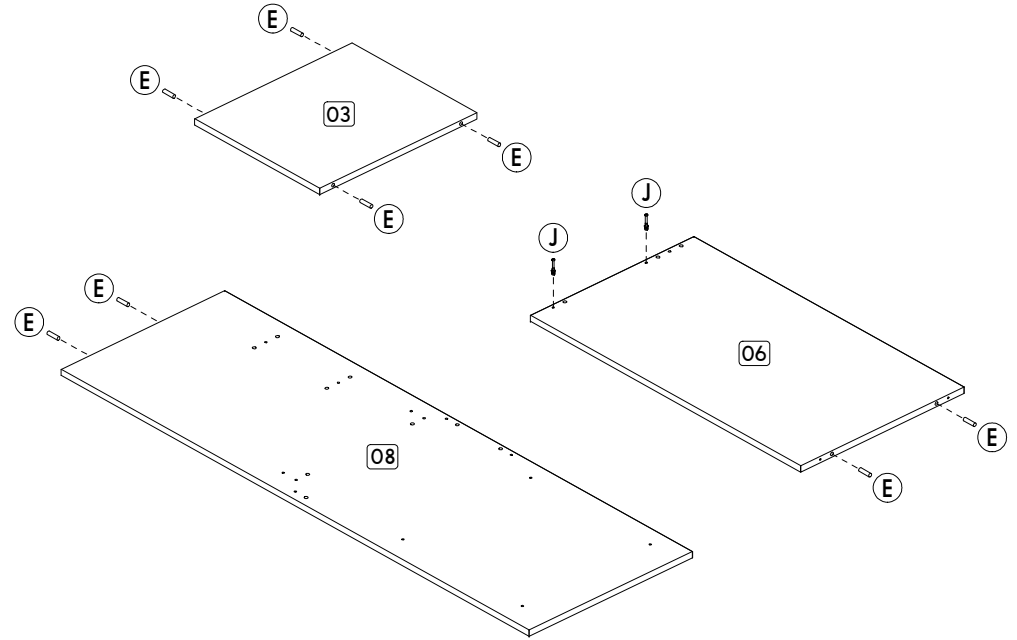
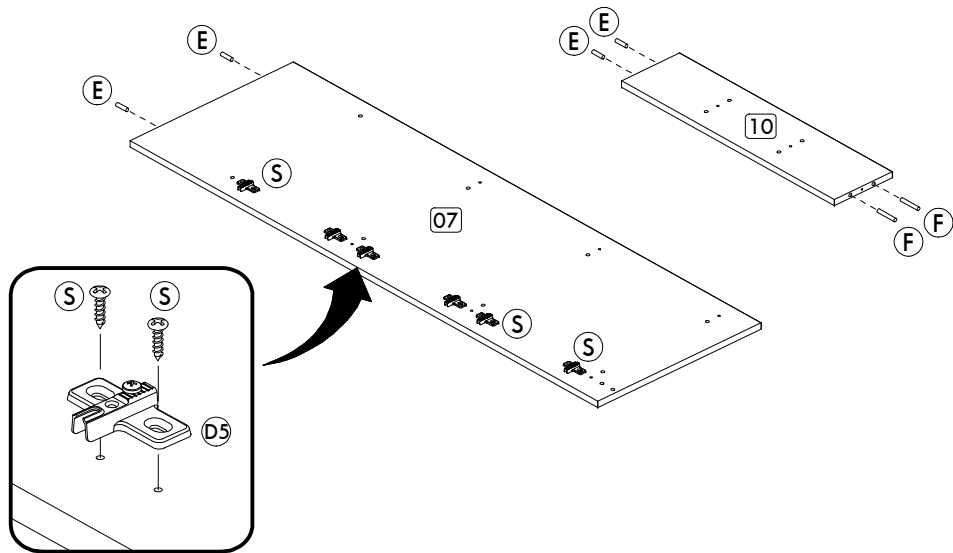

Passo/ Step/ Paso 01

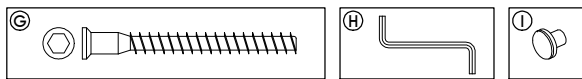
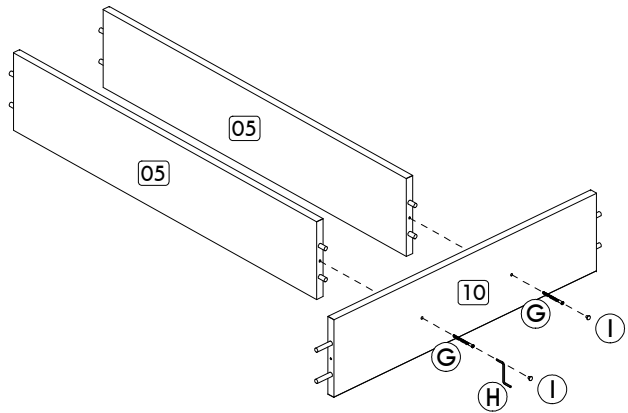

Passo/ Step/ Paso 02

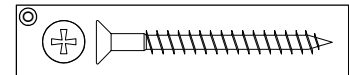
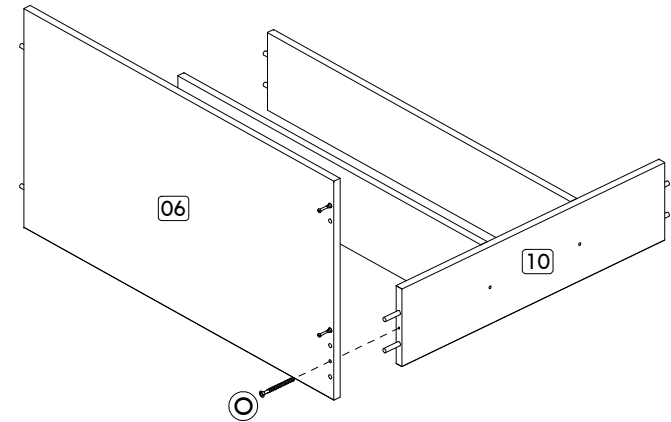

Passo/ Step/ Paso 03

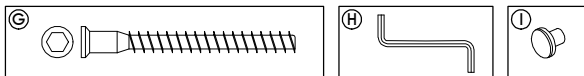
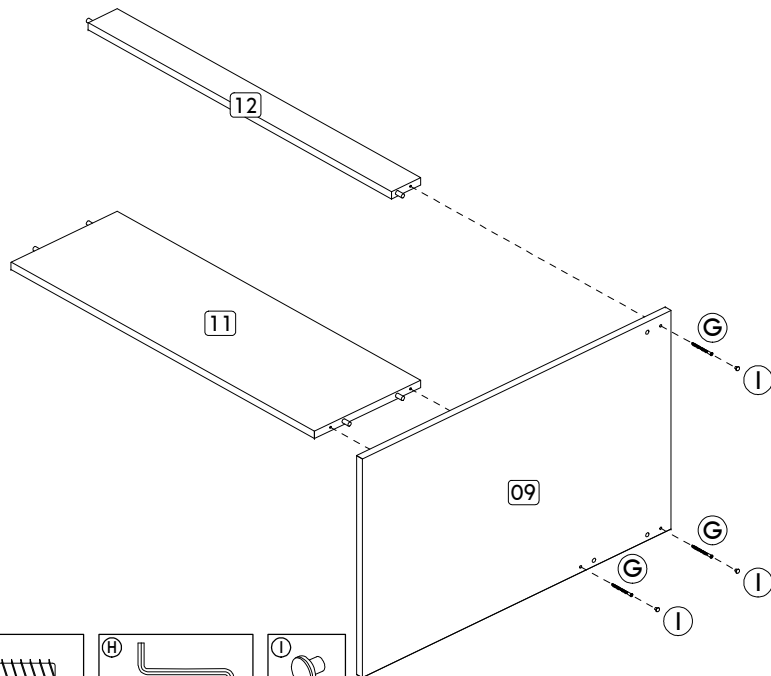

Passo/ Step/ Paso 04

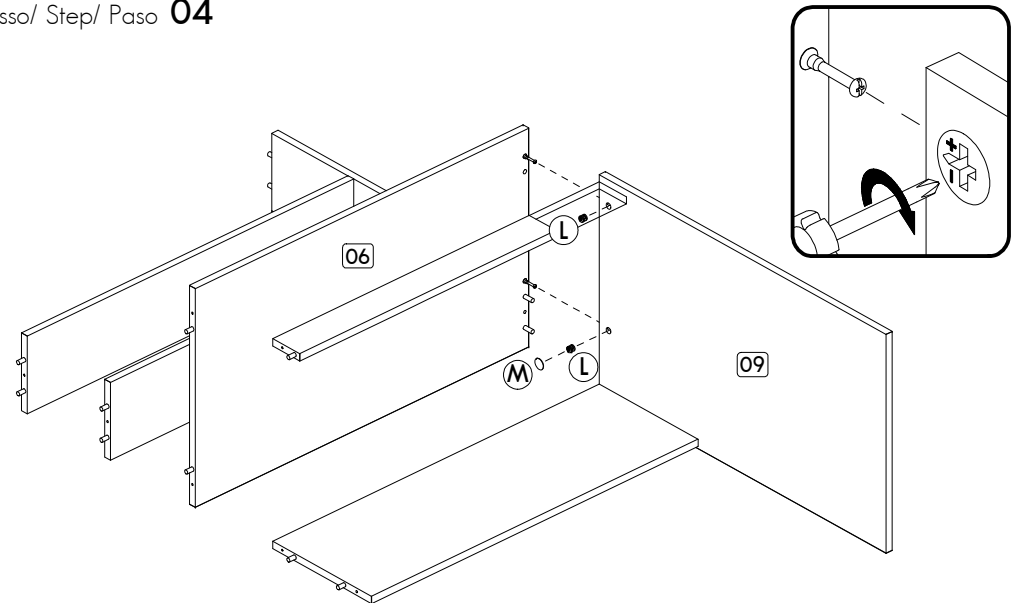

Passo/ Step/ Paso 05

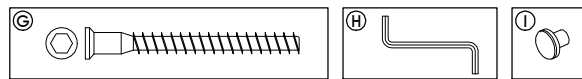
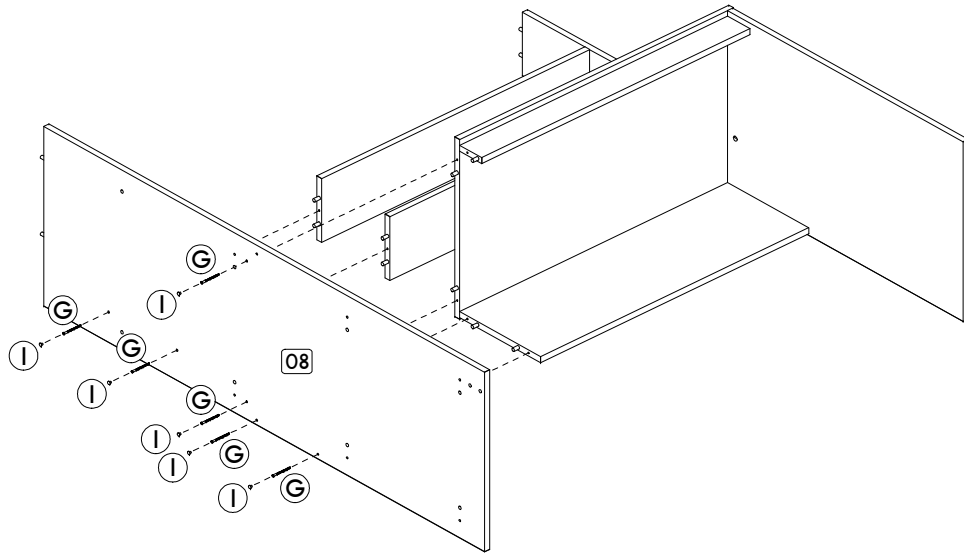

Passo/ Step/ Paso 07

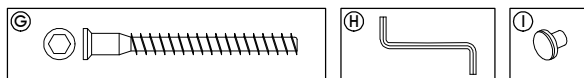
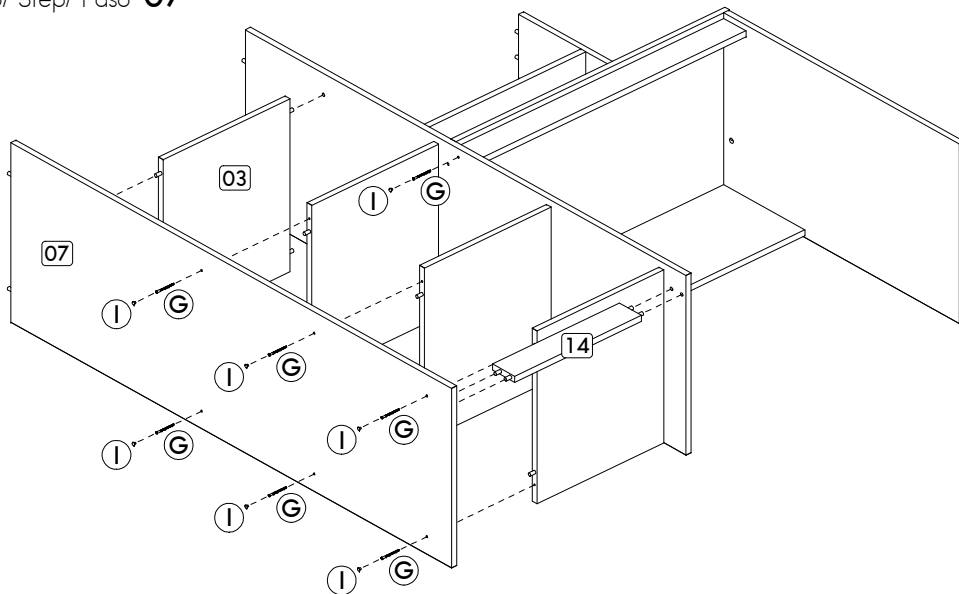

Passo/ Step/ Paso 06

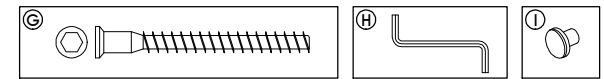
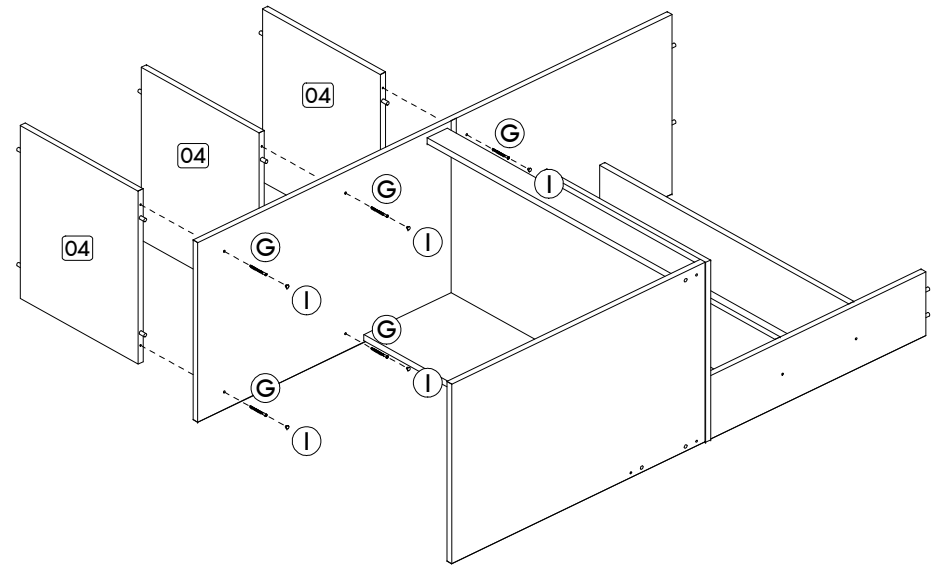

Passo/ Step/ Paso 08

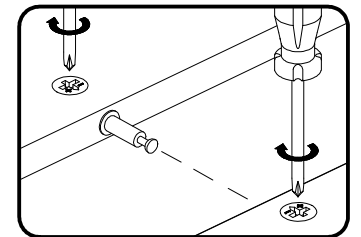
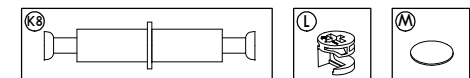
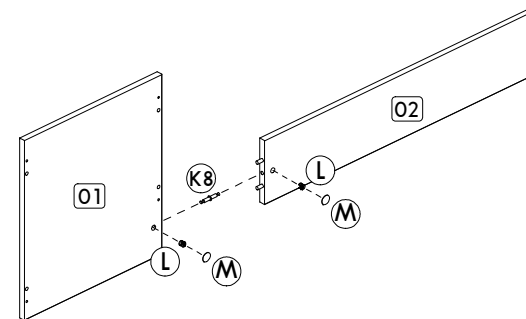

Passo/ Step/ Paso 09

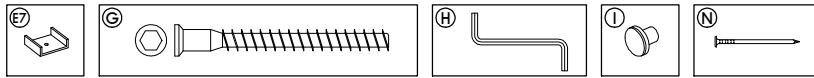
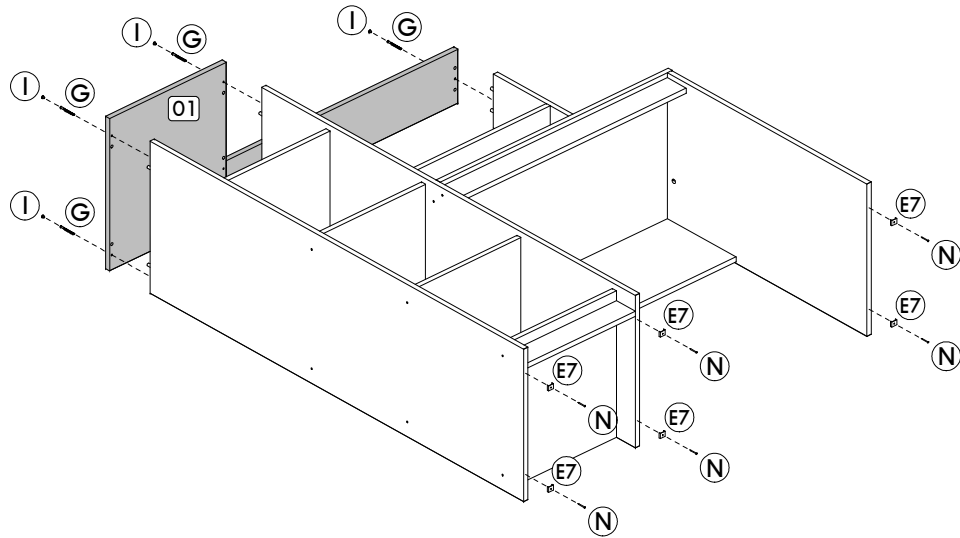

Passo/ Step/ Paso 10

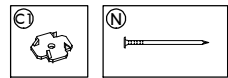
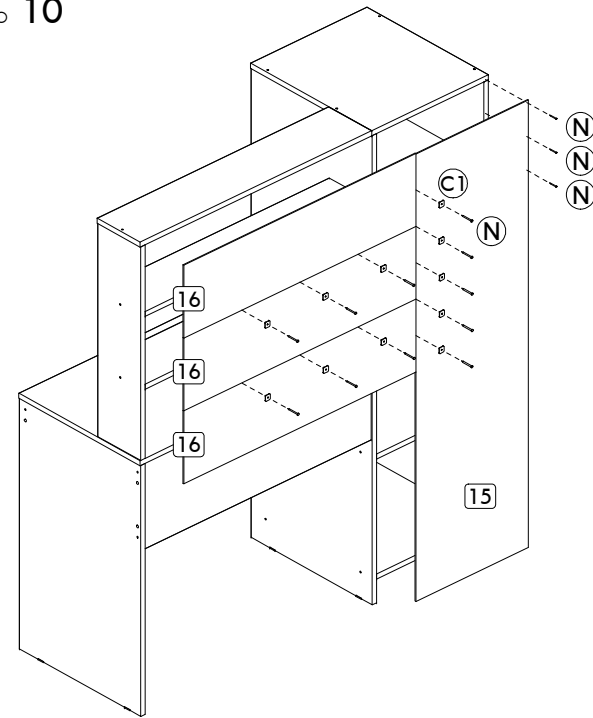

Passo/ Step/ Paso 11

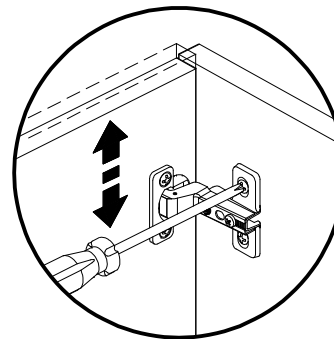
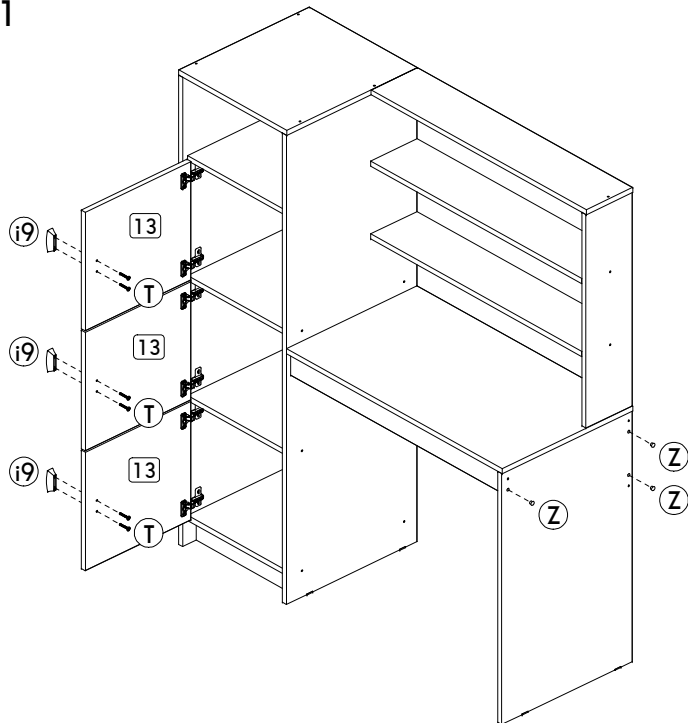

Regulagem Vertical
Ajuste Vertical
Vertical Adjustment

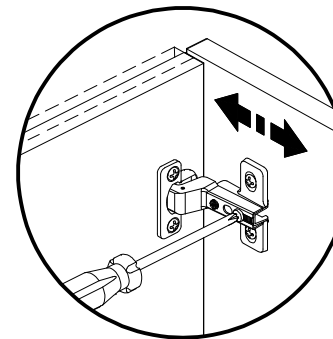

Regulagem Profundidade
Ajuste Profundidad
Depth Adjustment

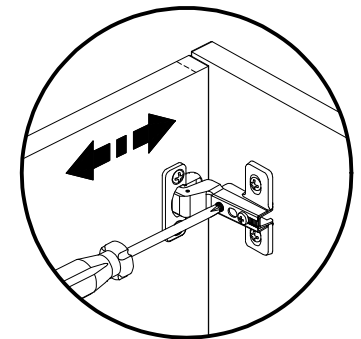

Regulagem Horizontal
Ajuste Horizontal
Horizontal Adjustment

