



REF.2025

ESCRIVANINHA GIRATORIA CARINHO

ROTATING DESK / ESCRITORIO GIRATORIO

**DETALHAMENTO EXTERNO
OUTER DETAIL / DETALLES EXTERNOS**

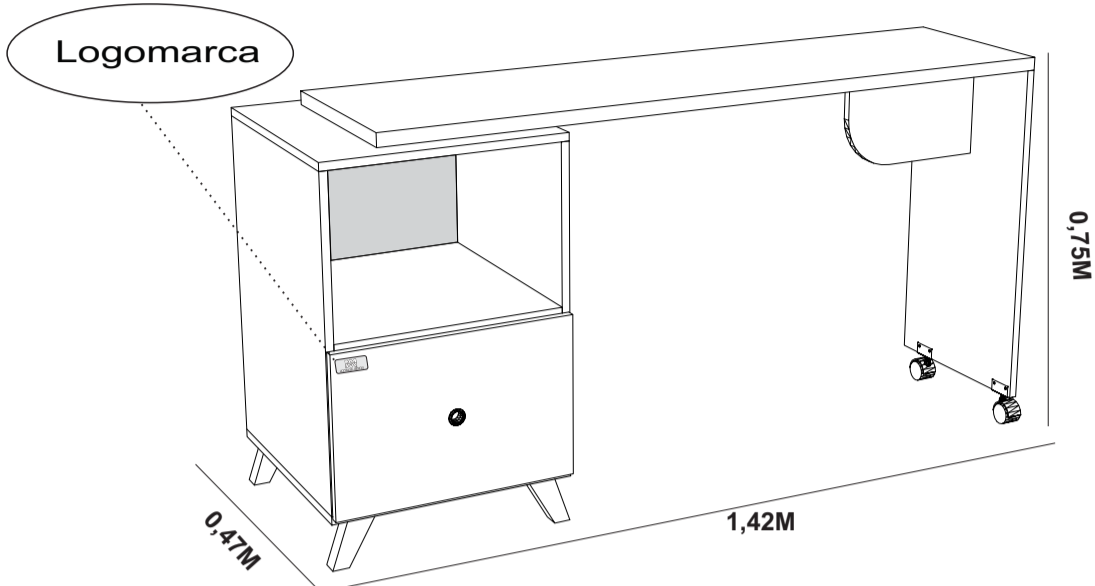

**DETALHAMENTO INTERNO
INSIDER DETAILS/DETALLES INTERNOS**



TABELA COR / COLOR TABLE / TABLA DE COLOR

DESCRIÇÃO/DESCRIPTION/DESCRIPCIÓN	CÓDIGO
BR.TX BRANCO TX WHITE TEXT BLANCO TEXT	74
BR.TX BRANCO TX WHITE / OCEAN BLANCO/OCEANO	91
OC.F.INT.BR. OCEANO.F.IN.BR. OCEAN BLANCO/OCEANO	86
BR.TX BRANCO TX WHITE OCEAN BLANCO/OCEANO	87
BR.TX BRANCO TX WHITE/YELLOW BLANCO/AMARILLO	87
AM.F. AMARELO F. WHITE/YELLOW BLANCO/AMARILLO	90
BR.TX BRANCO TX WHITE/YELLOW BLANCO/AMARILLO	90
AM.INT.BR. AMAREL.F.IN.BR. WHITE/YELLOW BLANCO/AMARILLO	90
BR. BRANCO WHITE BLANCO	06

**INSTRUÇÃO MONTAGEM PRODUTO
ASSEMBLY INSTRUCTION / INSTRUCCIONES DE MONTAJE**

Separar as peças e acessórios de maneira organizada
Separate parts and accessories in way organized
Separar las piezas y accesorios de manera organizada

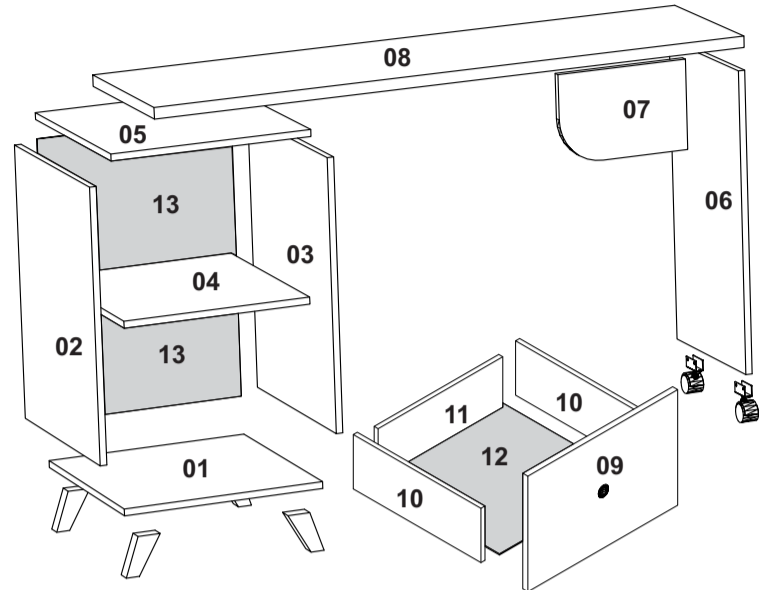
Forrar o chão com o papelão das embalagens
Cover the floor with the cardboard
Cubra el suelo con la embalaje de cartón

É necessário 1 pessoa para montar o produto
It is necessary one person to assembly
Es necesario una persona para ensamblar

Ferramentas necessárias (não fornecidas)
Not include tools / No herramientas

**CUIDADO PARA CONSERVAÇÃO E LIMPEZA DO MÓVEL
CARE TO CONSERVATION AND CLEAN
CUIDADO PARA LA CONSERVACIÓN Y LA LIMPIEZA**

O peso máximo de carga informado refere-se a objetos distribuído de maneira uniforme sobre toda área de contato da peça.
Set maximum weight load refers to objects distributed uniformly over the entire contact area of the workpiece.
Conjunto de carga máxima de peso se refere a objetos distribuídos uniformemente sobre toda a área de contacto de la pieza de trabajo.

Não molhar o móvel e não expor em lugar úmido
Do not wet the mobile and do not expose in a wet place
No moje el producto y no exponer en un lugar húmedo

Não expor o móvel próximo de fontes de calor
Do not expose the mobile near heat sources
no exponga cercano de fuentes de calor

Não usar produtos abrasivos.
Do not use abrasive products.
No utilice productos abrasivos.









Limpe com flanela limpa e seca.
Clean with dry cloth
Limpieza con un paño limpio y seco

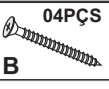
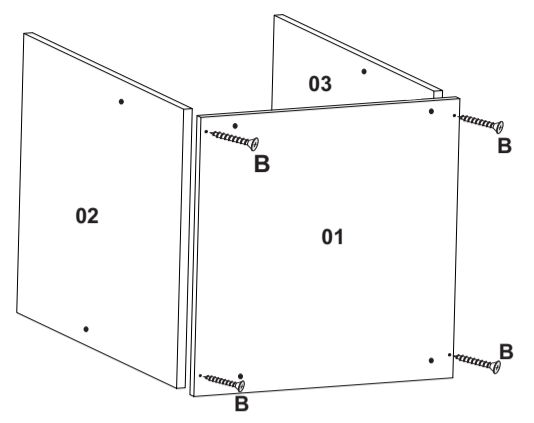
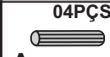

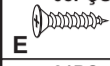

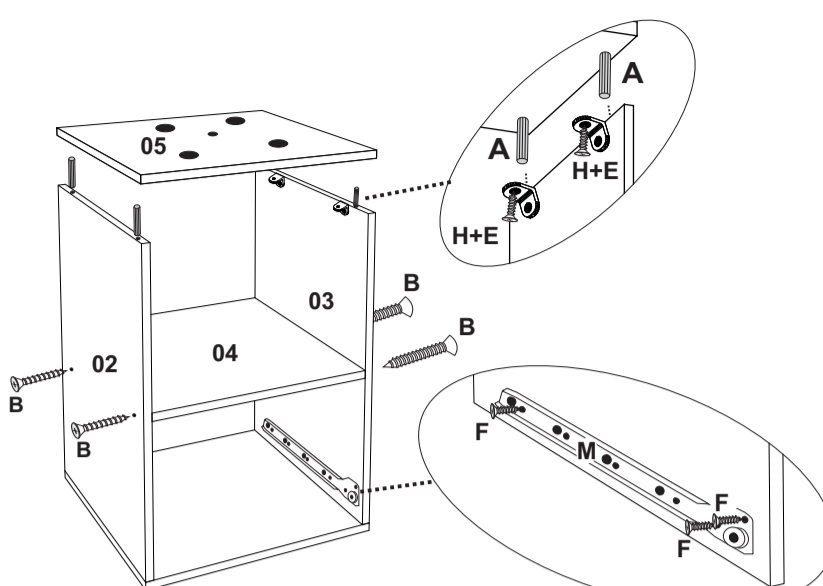

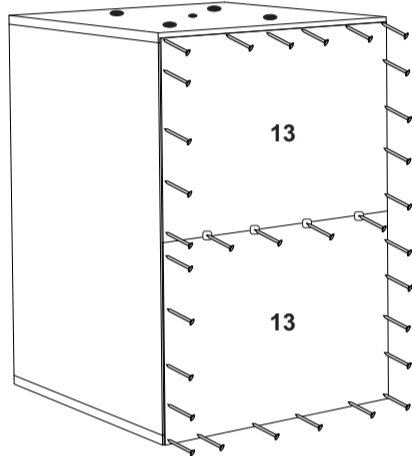

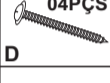
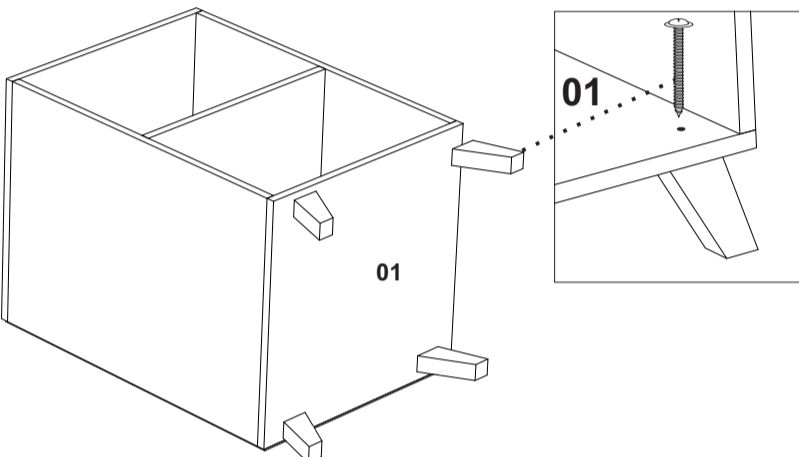

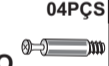
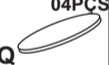





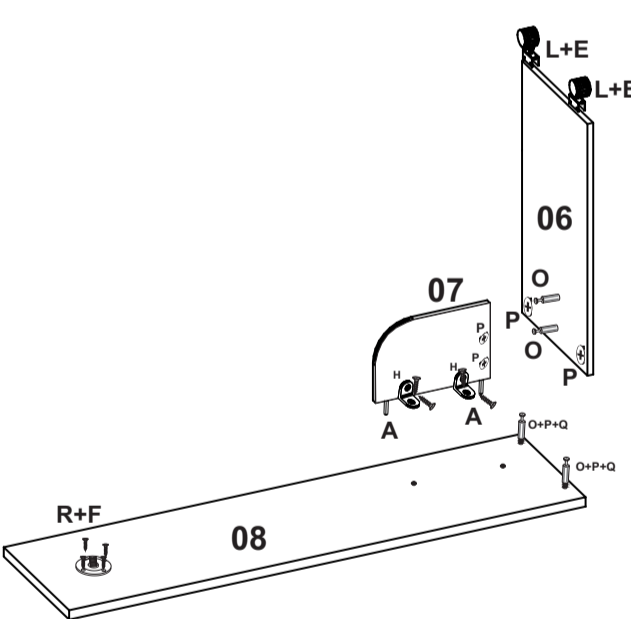

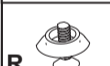
**LISTA DE ACESSÓRIOS E FERRAGEM
ACCESSORIES AND HARDWARE / ACCESORIOS Y EQUIPOS**

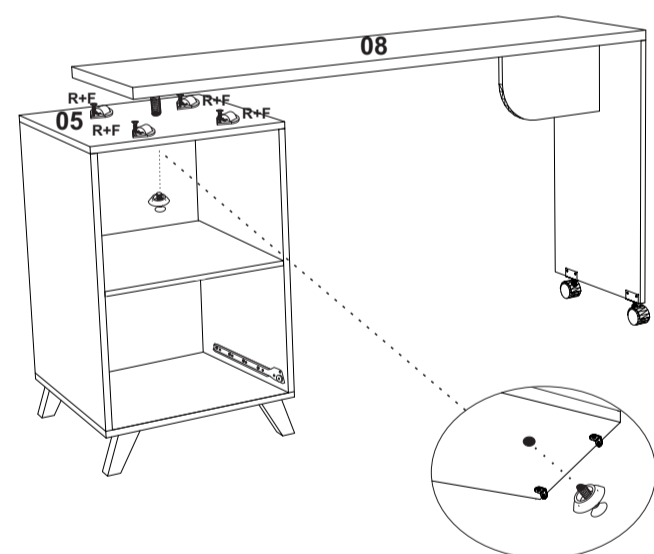
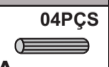
A Cavilha - 6x30 madeira Dowel / Clavija 10PÇS	B Parafuso 4,5x45 Screw / Tornillo 08PÇS	C Parafuso -3,5x28 Screw / Tornillo 04PÇS	D Parafuso -5,0x50 Screw / Tornillo 04PÇS	E Parafuso -3,5x12 Screw / Tornillo 24PÇS
F Parafuso -3,0x12 Screw / Tornillo 24PÇS	G Prego - 10x10 Nail / Clavo 40PÇ	H Cantoneira Zamac Corner / Esquinero 10PÇS	I Junção traseira metal Rear Junction / Unión 04PÇS	J SACHE cola 20g Glue / Goma 01PÇ
K Puxador vazado branco Handle / Jalador 01PÇ	L Rodízio chapa U branco Castors / Rueda 02PÇS	M Corrediça metálica 350mm Slider / Corredera 01PÇ	N Pé de madeira branco wood feet / Pies de madera 04PÇS	O Parafuso minifix Minifix Screw / Tornillo minifix 04PÇS
P Tambor minifix 12 mm Drum / Tambor 04PÇS	Q Tampa minifix 15mm Cover / Tapa 04PÇS	R Rolly Kit Rolly Kit 01PÇ	Logomarca Logo	

LISTA DE PEÇAS / List of Pieces / Lista de piezas

Nº	DESCRIÇÃO DA PEÇA / Description / Descripción		BR.TX	BR.TX/ OCEANO F.	BR.TX/ AMARELO F.	MAT. PRIMA	MEDIDAS	QTDE
01	BASE	BASE	2025.74	2025.74	2025.74	MDP	450x450x15	01
02	LATERAL ESQUERDA	LATERAL IZQUIERDA	2025.74	2025.74	2025.74	MDP	600x450x15	01
03	LATERAL DIREITA	LATERAL DERECHA	2025.74	2025.74	2025.74	MDP	600x450x15	01
04	PRATELEIRA	REPISA	2025.74	2025.74	2025.74	MDP	420x450x15	01
05	TAMPO	TAMPO	2025.74	2025.74	2025.74	MDP	450x450x15	01
06	LATERAL MESA	LATERAL MESA	2025.74	2025.74	2025.74	MDP	671x360x15	01
07	TRAVA DA MESA	TRAVA DA MESA	2025.74	2025.74	2025.74	MDP	350x200x15	01
08	TAMPO MESA	TAMPO MESA	2025.74	2025.74	2025.74	MDP	1355x360x25	01
09	FRENTE GAVETA	FRENTE CAJON	2025.74	2025.91	2025.90	MDP	446x298x15	01
10	LATERAL GAVETA	LATERAL CAJON	2025.06	2025.06	2025.06	MDP	380x140x12	02
11	CONTRA FUNDO	CONTRAFONDO	2025.06	2025.06	2025.06	MDP	371x130x12	01
12	FUNDO GAVETA	FONDO CAJON	2025.06	2025.06	2025.06	TREE	394x385x03	01
13	FUNDO	FONDO	2025.06	2025.06	2025.06	TREE	311x448x03	02

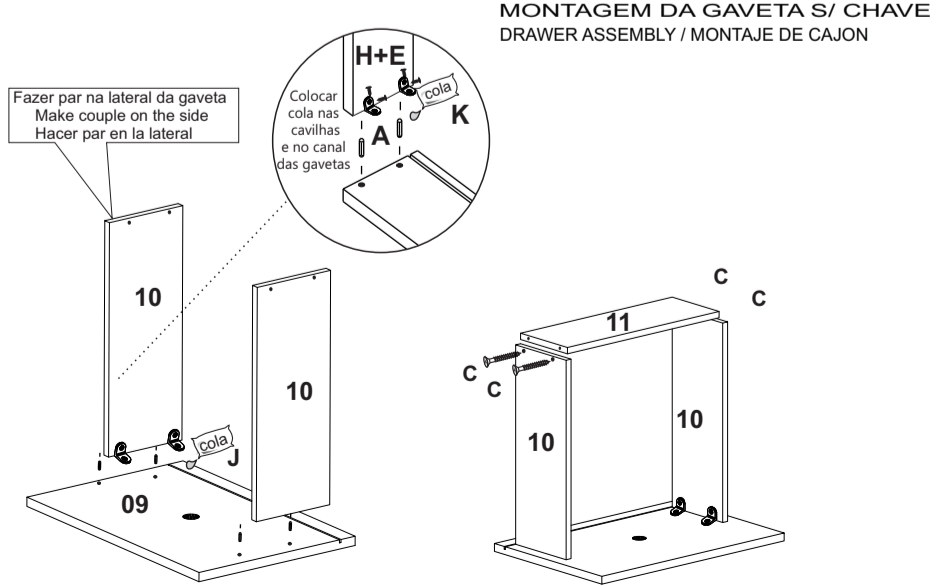
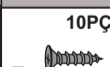
PASSO 1	Fixar as peças 02 e 03 na peça 01 utilizando as ferragens (B).	PASSO 2	Fixar a peça 4 nas peças 2 e 3 utilizando a ferragem (B). Fixar o acessório (M) nas peças 2 e 3 utilizando a ferragem (E). Fixar a peça 5 nas peças 2 e 3 utilizando as ferragens (A, E e H).
STEP 1	Fix the pieces 02 & 03 in the piece 01 using the tools (B).	STEP 2	Fix the 4 in the 2 & 3 using (B). Fix the (M) in the 2 & 3 using (E). Fix 5 in the 2 & 3 using (A, E & H).
PASO 1	Fije las piezas 02 y 03 en la pieza 01 usando las herrages (B).	PASO 2	Fije 4 en la 2 y 3 usando (B). Fije (M) en las 2 y 3 usando (E). Fije 5 en las 2 y 3 usando (A, E y H).
 04PÇS B		 04PÇS A  04PÇS B  04PÇS H  08PÇS E  01PÇ M  06PÇ F	
PASSO 3	Pregar as peças 13 utilizando a ferragem (J) para unir as duas peças.	PASSO 4	Fixar o acessório (N) na peça 01 utilizando a ferragem (D)
STEP 3	Nail the 13 using (J) to join the two pieces	STEP 4	Fix the (N) in the 01 using (D)
PASO 3	Clavee las 13 usando la (J) para unir las dos piezas	PASO 4	Fije (N) en la 01 usando (D)
 34PÇS G  04PÇS I		 04PÇS N  04PÇS D	

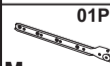
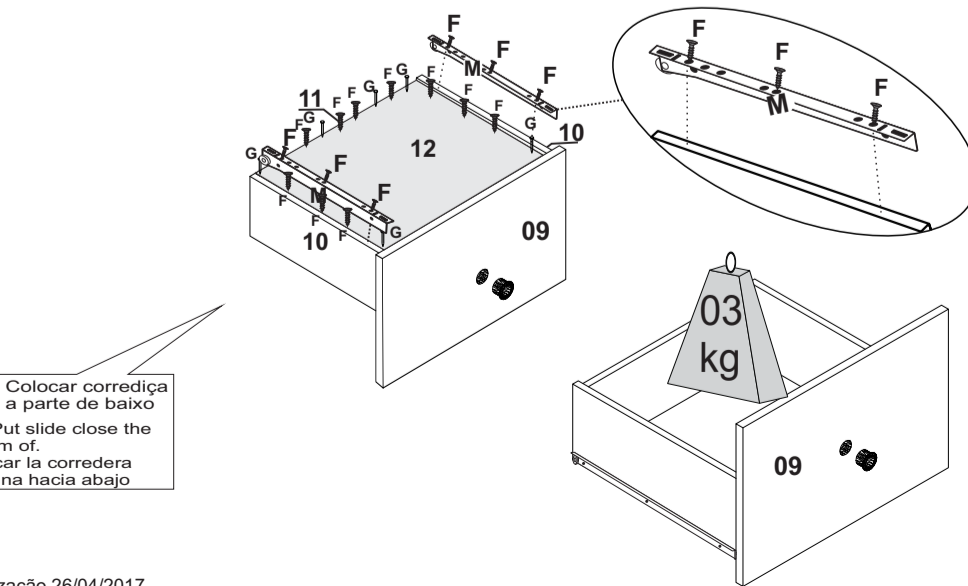
PASSO 5	Fixar as peças 07 na peça 06 utilizando as ferragens (O, P e Q). Depois fixe a peça 6 na peça 08 utilizando ferragens (O, P e Q) em seguida fixe a peça 07 na peça 08 utilizando ferragens (A, H, E)	PASSO 6	Fixar acessório na peça 05 utilizando as ferragens (F).
STEP 5	Fix the 07 in the 06 using (O, P & Q). After fix the 6 in the 08 using (O, P & Q). Fix 07 in the 08 using (A, H, E)	STEP 6	Fix the accessory in the 05 using (F).
PASO 5	Fije la 07 en la 06 usando (O, P y Q). Despues fije la 06 en la 08 usando (O, P y Q). Fije la 07 en la 08 usando (A, H, E)	PASO 6	Fije el accesorio en la 05 usando (F).
 02PÇS A  04PÇS L  04PÇS O  04PÇS Q  04PÇS P  08PÇS E  02PÇS H  01PÇ R  04PÇ F		 04PÇS F  R  R	
PASSO 1	Fixar a peça 10 na peça 09 utilizando as ferragens (A, E, H, J). Depois fixar a peça 11 na peça 10 utilizando as ferragens (C).	PASSO 2	Fixar a peça 12 na peça 10 e 11 utilizando as ferragens (G, F). Depois a ferragens M na peça 10 utilizando a ferragem (F).
STEP 1	Fix the 10 in the 09 using (A, E, H, J). After fix the 11 in the 10 using (C).	STEP 2	Fix the 12 in the 10 & 11 using the (G, F). After (M) in the 10 using (F).
PASO 1	Fije la 10 en la 09 usando (A, E, H, J). Despues fije la 11 en la 10 usando (C).	PASO 2	Fije la 12 en la 10 y 11 usando (G, F). Despues la (M) en la 10 usando (F).
 04PÇS A  04PÇS C  08PÇS E  04PÇS H  01PÇ J  01PÇ K	<p>MONTAGEM DA GAVETA S/ CHAVE DRAWER ASSEMBLY / MONTAJE DE CAJON</p> <p>Fazer par na lateral da gaveta Make couple on the side Hacer par en la lateral</p> <p>Colocar cola nas cavilhas e no canal das gavetas Put glue on the pins and in the drawer channel</p> 	 10PÇS F  06PÇS G  01PÇ M	 <p>Dica: Colocar corredeira rente a parte de baixo Tip: Put slide close the bottom of. Colocar la corredera cercana hacia abajo</p>