

MANUAL DE MONTAGEM
Assembly instructions / Instrucciones de armado

ESTANTE DUMONT

Bookcase Dumont
Estantería Dumont

Código 160472 | Revisão 00

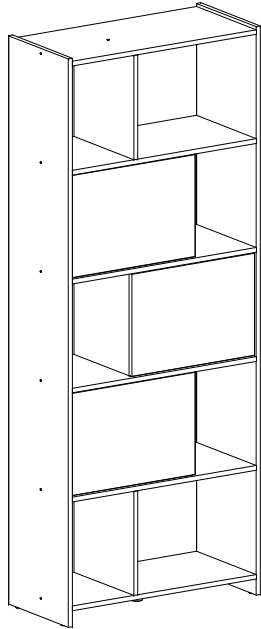

PESO MÁXIMO SUPORTADO PELAS PEÇAS, SENDO ESTE DISTRIBUÍDO UNIFORMEMENTE.

Maximum weight supported by parts, being this evenly distributed.
Peso máximo soportado por las partes, siendo esta distribuido uniformemente.

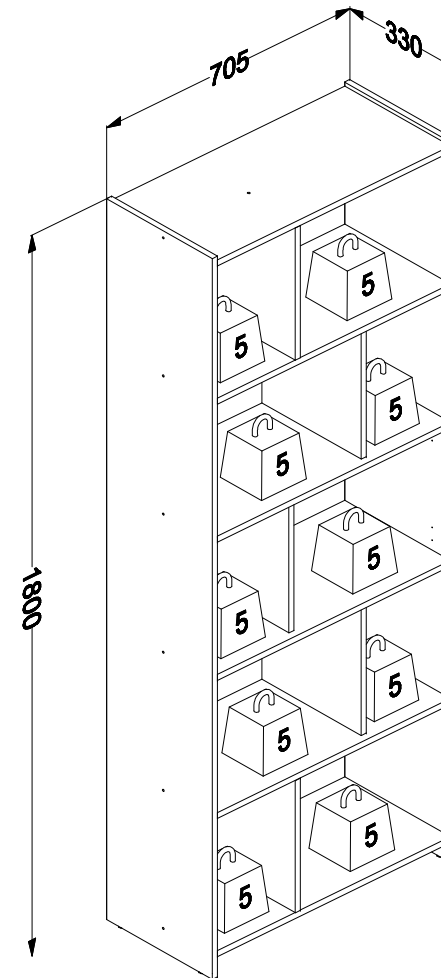

Você vai precisar de/ You will need / Usted necesitará

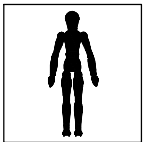

1 Pessoa
1 Person
1 Persona

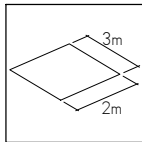

Espaço recomendado para montagem
Recommended space for assemble
Espacio recomendado para el armado

Ferramentas não inclusas
Tools not included / Herramientas no incluidas

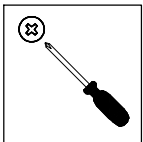

Chave Phillips
Screwdriver Phillips
Destornillador cruz

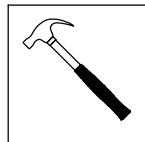

Martelo
Hammer
Martillo

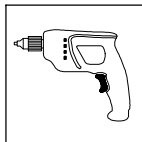

Furadeira
Drill machine
Taladro

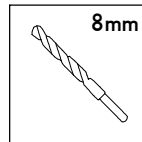







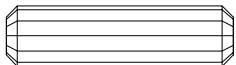
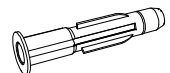
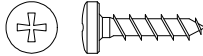
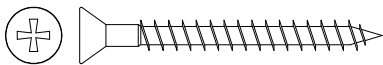
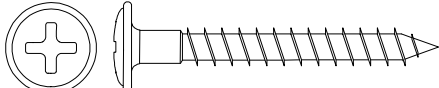
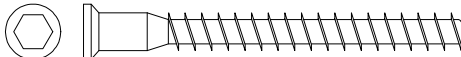
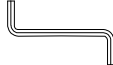

Broca
Drill bit
Taladro

* PESO EM KG/ Weight in Kg/ Peso en Kg
DIMENSÕES EM MM/ Dimensions in mm/ Dimensiones en mm

IDENTIFICAÇÃO DOS ACESSÓRIOS/ IDENTIFICATION OF ACCESSORIES/ IDENTIFICACIÓN DE ACCESORIOS

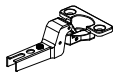
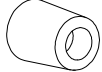
NOTAS: A separação dos acessórios antes de iniciar a montagem facilitará a mesma. Os parafusos e cavilhas estão na escala real. Em caso de dúvida na identificação, coloque o acessório sobre a imagem.
NOTES: The separation of the accessories before you start the assembly will facilitate the same. The screws and dowels are in real scale. In case of doubts about the identification, place the accessory on the image.
NOTAS: La separación de los accesorios antes de comenzar el armado facilitará el mismo. Los tornillos y taquetes son en escala real. En caso de dudas sobre la identificación, coloque el accesorio en la imagen.

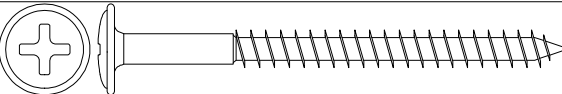
A		Cavilha Wooden Dowel Pin	8x30 mm	44	P		Bucha expansiva Bushing Tapón	8x50 mm	01
B		Parafuso panela Pan head screw Tornillo de pan	3,5x14 mm	25					
C		Parafuso chato Flat head screw Tornillo de cabeza plana	4,0x40 mm	04					
D		Parafuso flangeado Flanged head screw Tornillo de cabeza flangeada	5,0x40 mm	01					
E		Parafuso estrutural Structural screw Tornillo estrutural	5,0x50 mm	12					
F		Chave allen Allen key Llave Allen	-	01					
G		Tampa parafuso estrutural Structural screw cover Tapa tornillo estrutural	-	12					
H		Prego Nail Clavo	10 x10	44					
I		Garra de metal Metal claw Garra metal	-	06					
J		Sapata redonda Small plastic foot Pie plástico	14 mm	04					
K		Calço dobradiça Hinge shim Bisagra de calce	-	06					
L		Dobradiça super alta Metal hinge super high Bisagra alta	26mm	06					
M		Sapata Plastic foot Pie plástico	50 mm	01					
N		Cinta Strap Correa	-	01					
O		Parafuso flangeado Flanged head screw Tornillo de cabeza flangeada	5,0x60 mm	01					

IDENTIFICAÇÃO DAS PEÇAS/ PARTS IDENTIFICATION/ IDENTIFICACIÓN DE LAS PIEZAS

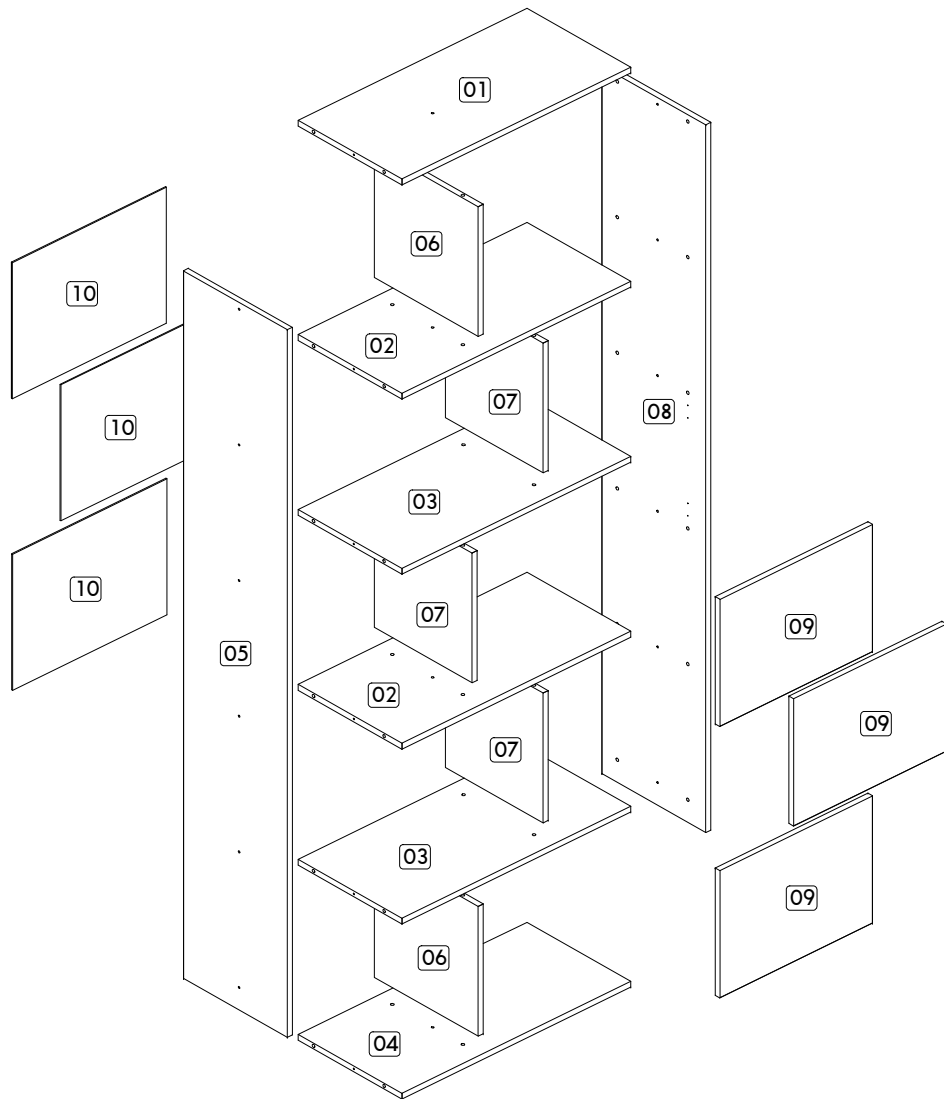

Nº	DESCRIÇÃO - DESCRIPTION - DESCRIPCIÓN	MEDIDAS-MEASURES - MEDIDAS (mm)	QTD.
01	Base superior - Top base - Base superior	675 x 330 x 15	01
02	Base - Base - Base	675 x 330 x 15	02
03	Base intermediária - Intermediate base - Base intermedia	675 x 330 x 15	02
04	Base inferior - Bottom base - Base inferior	675 x 330 x 15	01
05	Lateral esquerda - Left side - Lateral izquierda	1800 x 330 x 15	01
06	Divisão - Division - División	330 x 330 x 15	02
07	Divisão porta - Door division - División puerta	330 x 310 x 15	03
08	Lateral direita - Right side - Lateral derecha	1800 x 330 x 15	01
09	Porta - Door - Puerta	451 x 324 x 15	03
10	Costa - Backboard - Fondo	455 x 346 x 3	03

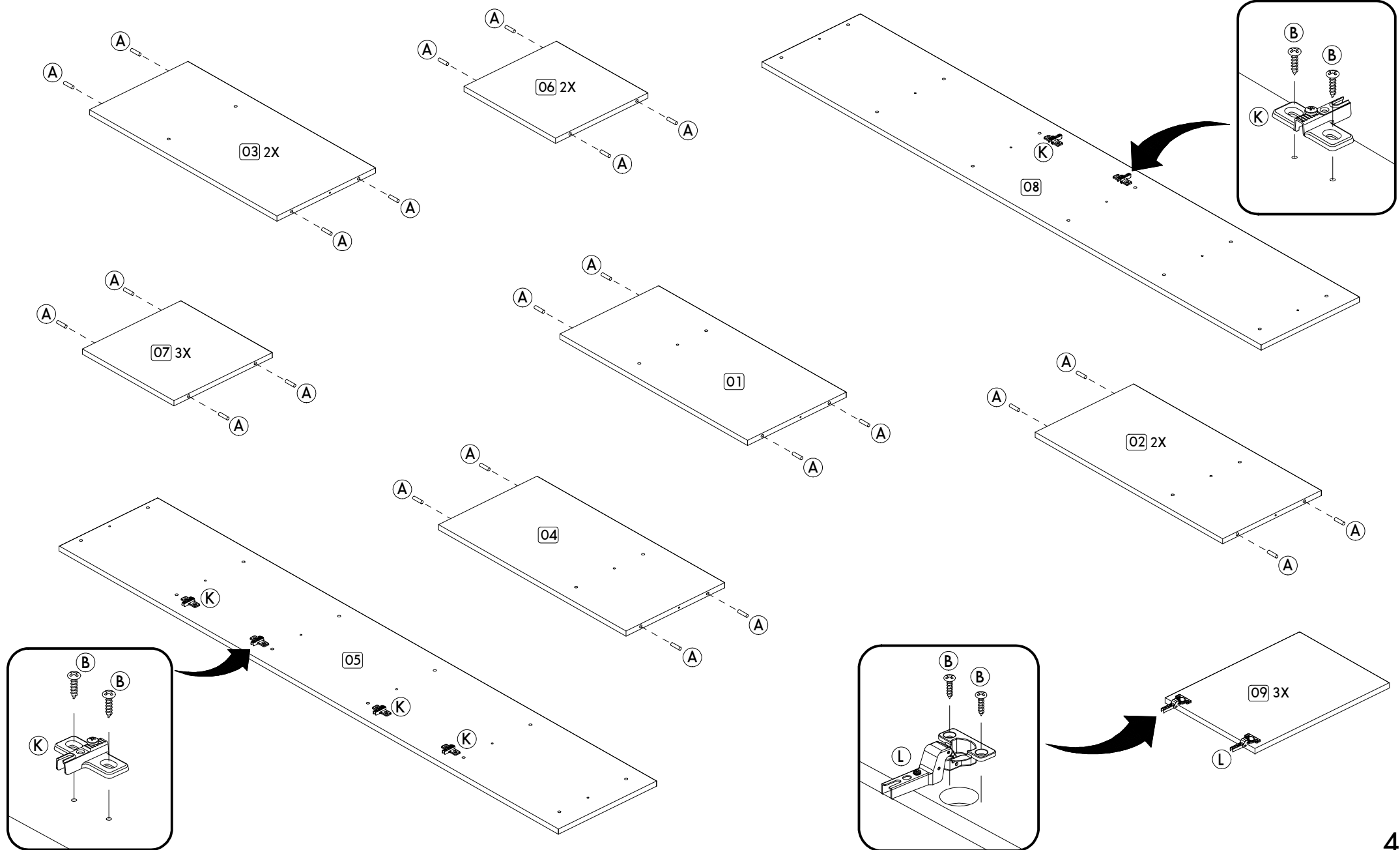

Passo/ Step/ Paso 01

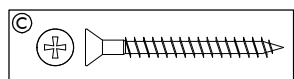
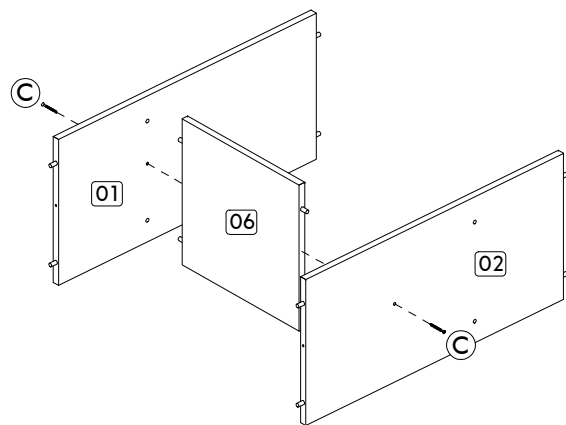

Passo/ Step/ Paso 02

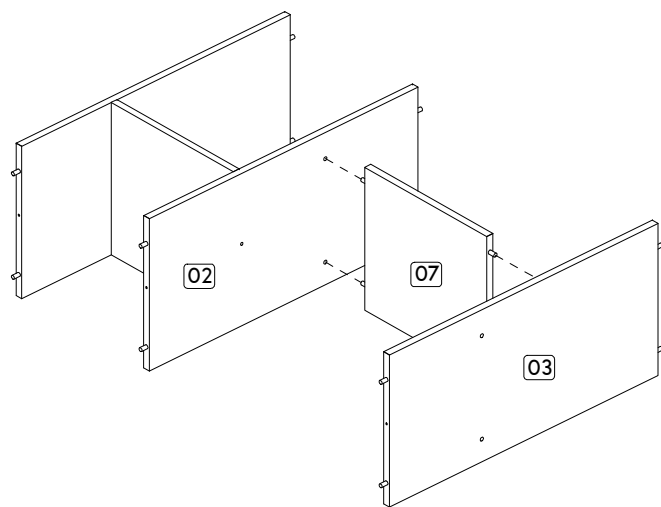

Passo/ Step/ Paso 03

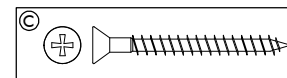
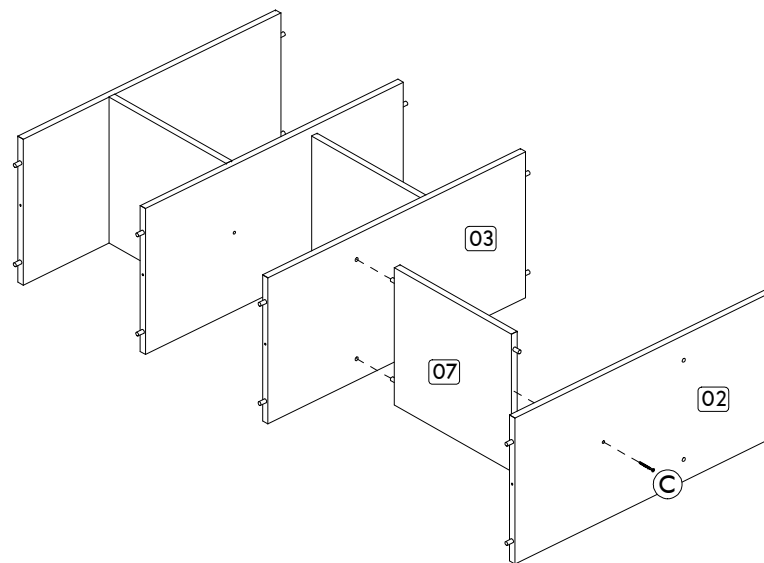

Passo/ Step/ Paso 04

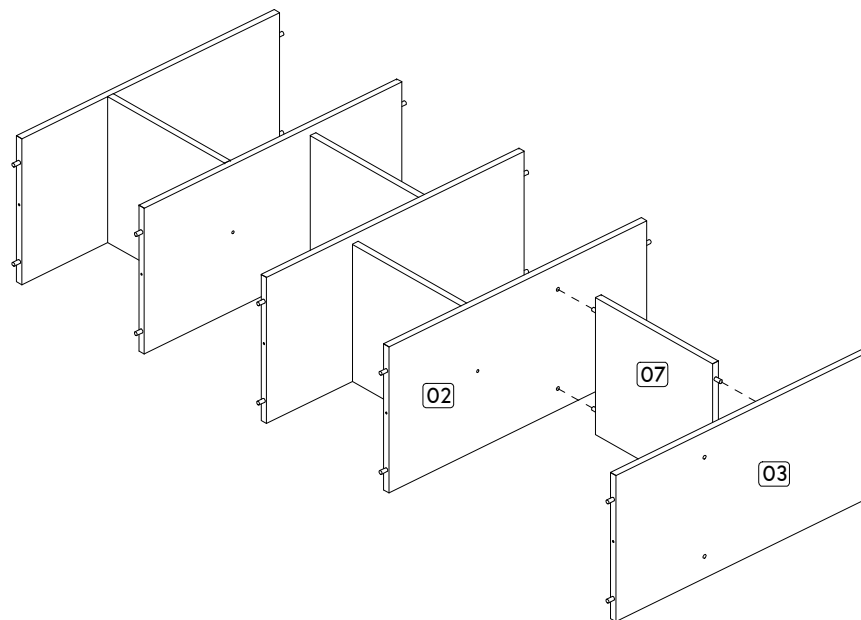

Passo/ Step/ Paso 05

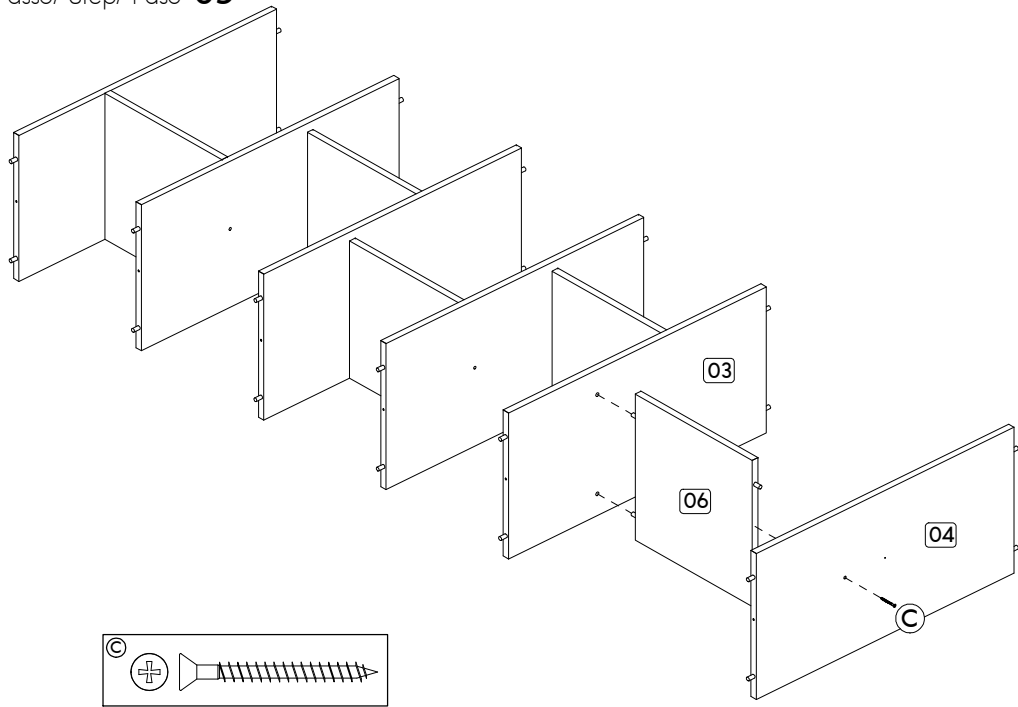

Passo/ Step/ Paso 06

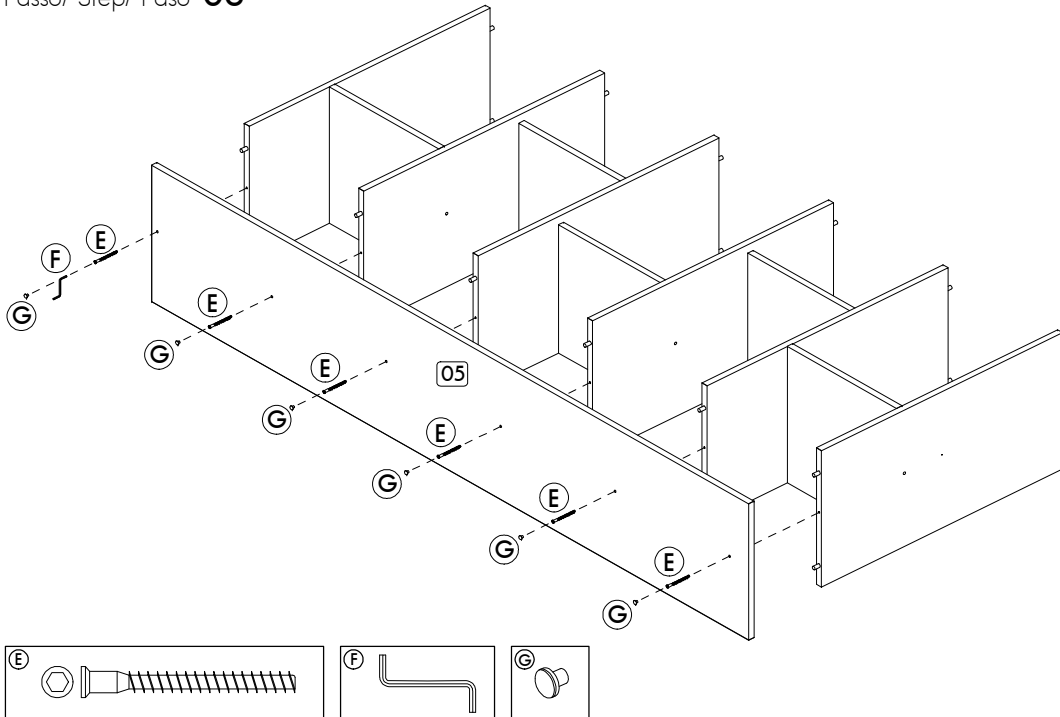

Passo/ Step/ Paso 07

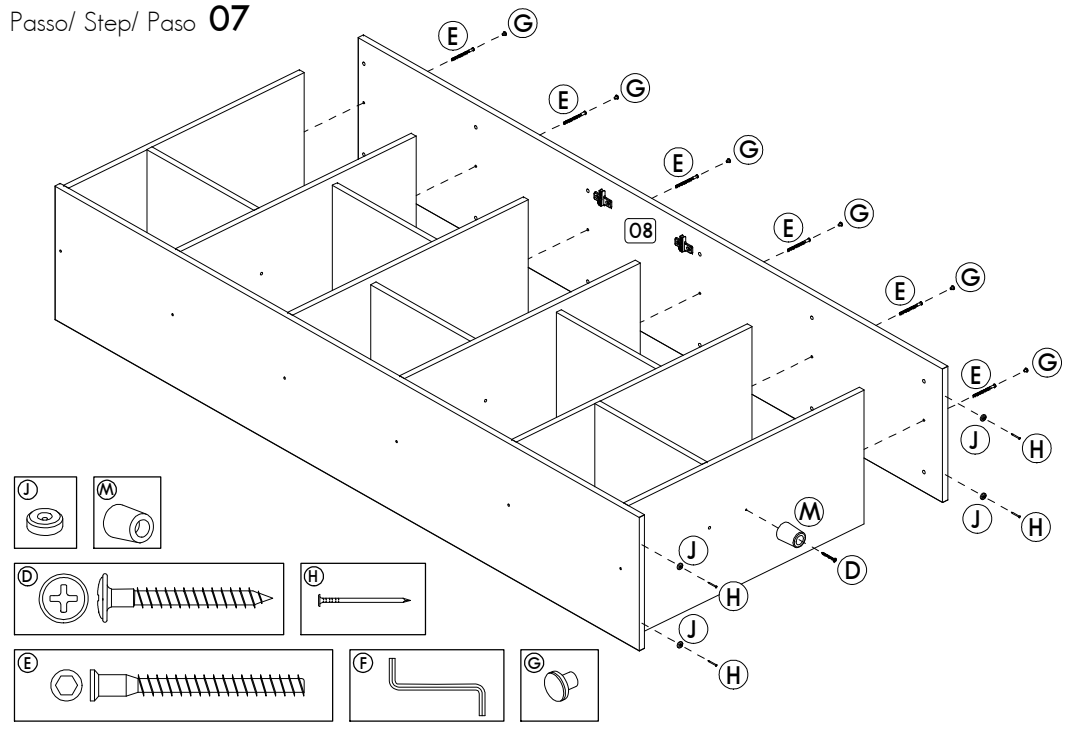

Passo/ Step/ Paso 08

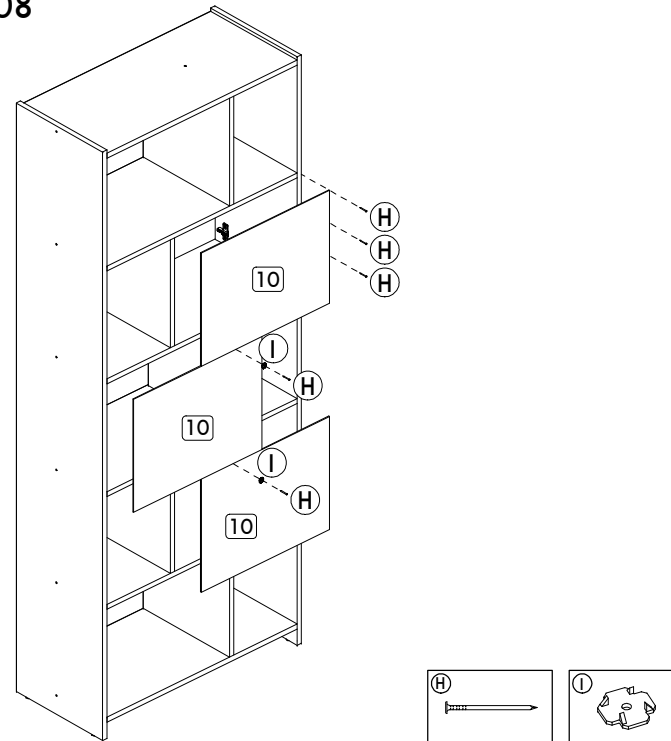

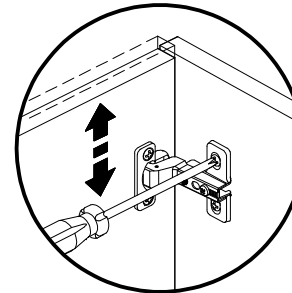
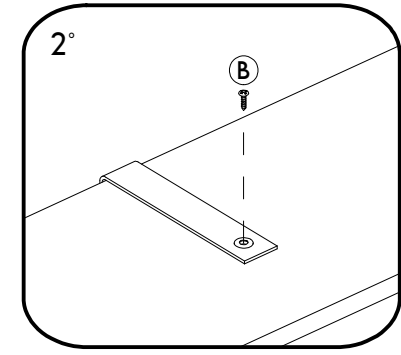
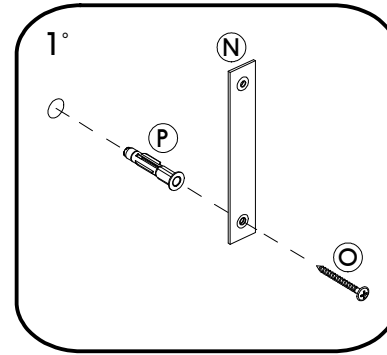
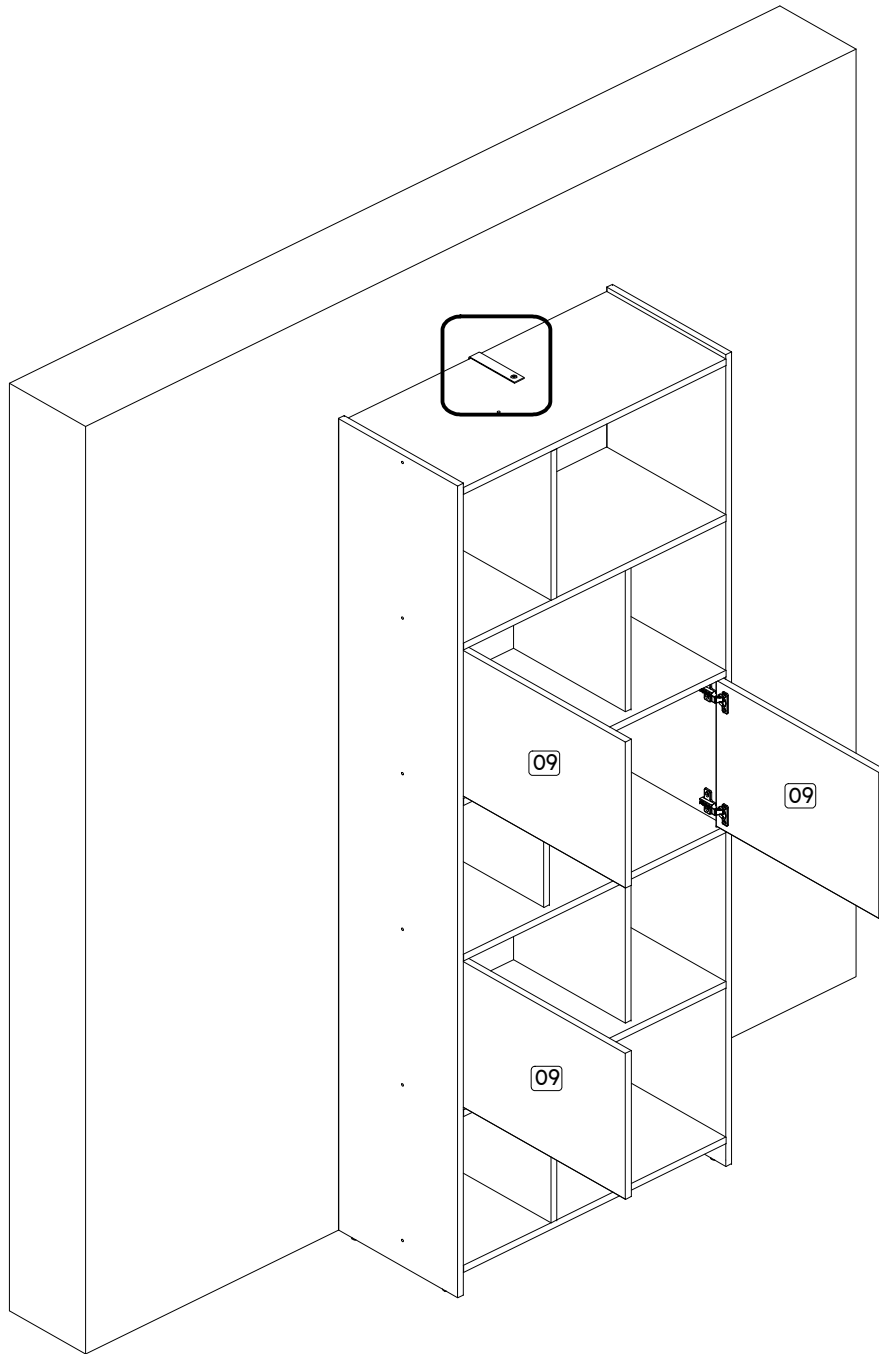

Regulagem Vertical
Ajuste Vertical
Vertical Adjustment

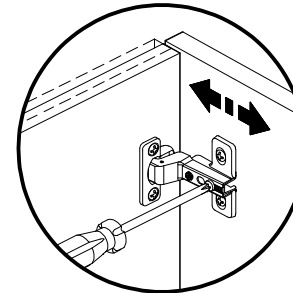

Regulagem Profundidade
Ajuste Profundidad
Depth Adjustment

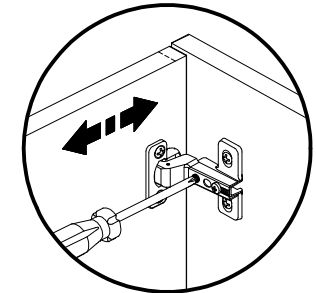

Regulagem Horizontal
Ajuste Horizontal
Horizontal Adjustment

