

CÓDIGO DE PEÇAS | CODE OF PIECES | CÓDIGO DE PIEZAS

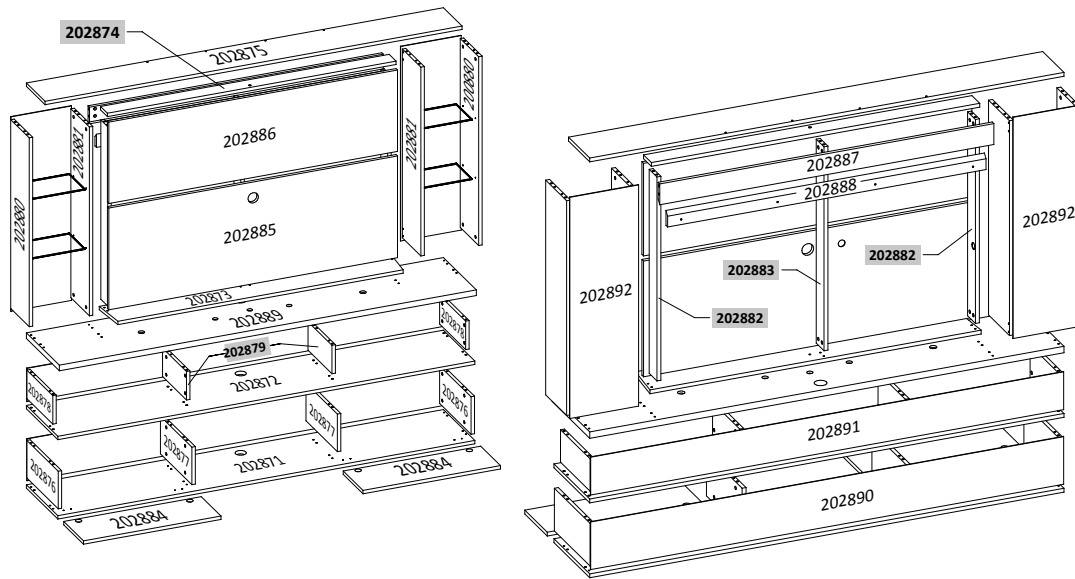

INSTRUÇÕES

- Prepare a montagem do móvel próximo ao local que ele ficará definitivamente e evite deslocá-lo depois de montado;
- Forre o chão com papelão ou similar e utilize a isomanta que vem entre as peças para evitar o contato entre elas durante a montagem;
- Monte o móvel obedecendo a ordem numérica da **sequência de montagem (S.M.)**, identificando as peças pelo **código de peça (C.P.)** carimbado na mesma, de acordo com a tabela.

INSTRUCTIONS

- Prepare the assembly of the close piece of furniture to the place that it will be definitively and avoid to move after done. Will be definitively and avoid to move after done;
- Cover the ground with cardboard or similar and use the isomanta that it comes among the pieces to avoid the contact among them during the assembly;
- Set up the piece of furniture obeying the numeric order of the **assembly sequence (S.M.)**, identifying the pieces by **code of piece (C.P.)** stamped in the same, in agreement with the table.

INSTRUCCIONES

- Prepare la montaje del mobiliario proximo al lugar que estará definitivamente y evite mover después de hecho;
- Tape la suelo con cartón o similar y use la "isomanta" que viene entre las piezas para evitar el contacto entre ellos durante la montaje;
- Monte el mobiliario obedeciendo el orden numérico de la **sucesión de montaje (S.M.)**, identificando las piezas por el **código de piezas (C.P.)** de la misma estampado en esta, de acuerdo con la tabla.

ASPECTO FINAL | FINAL ASPECT

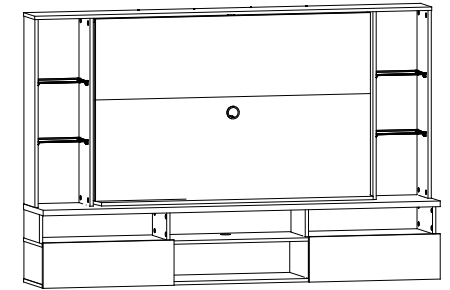

Espaço para Tv: → 1,260m ↑ 0,810m
Dimensão do Produto: → 1,820m ↑ 1,200m ↯ 0,340m

CUIDADOS ESPECIAIS

LIMPEZA: Pano limpo umedecido em água e sabão neutro
BRILHO: Flanela seca

SPECIAL CARES

CLEANING: Clean cloth humidified in water and neutral soap
SHINE: Dry flannel

CUIDADOS ESPECIALES

LIMPIEZA: Tela limpia humedecida en la agua y el jabón neutro
BRILLO: Flanela seca

*Dimensões em metros | Dimensions in meters | Dimensiones en metros

Edição: 06/01/2017

REF.:	PEÇAS PIECE PIEZA	MATÉRIA PRIMA	DIMENSÕES* DIMENSIONS DIMENSIONES	QUANT.
202871	Base Base Base	MDP	1,820 x 0,320 x 0,015	1
202872	Tampo intermediário Intermediate cover Cubierta intermedia	MDP	1,820 x 0,320 x 0,015	1
202873	Base do painel giratório Base of the pickup Base del recogedor	MDP	1,268 x 0,160 x 0,015	1
202874	Chapéu do painel giratório Hat el panel rotativo Hat the rotary panel	MDP	1,258 x 0,070 x 0,015	1
202875	Chapéu Hat Castor	MDP	1,820 x 0,190 x 0,015	1
202876	Lateral inferior Bottom side Lado inferior	MDP	0,320 x 0,166 x 0,015	2
202877	Divisão inferior Lower division La división inferior	MDP	0,320 x 0,166 x 0,015	2
202878	Lateral DVD DVD side Lado de DVD	MDP	0,265 x 0,126 x 0,015	2
202879	Divisão DVD DVD Division División de DVD	MDP	0,244 x 0,126 x 0,015	2
202880	Lateral superior Upper Side Parte superior	MDP	0,835 x 0,188 x 0,015	2
202881	Divisão superior Upper division División superior	MDP	0,835 x 0,188 x 0,015	2
202882	Travessa lateral do painel giratório Side panel pickup Recogedor del panel lateral	MDP	0,793 x 0,070 x 0,015	2
202883	Travessa central do painel giratório The rotary panel El panel rotativo	MDP	0,793 x 0,070 x 0,015	1
202884	Porta basculante Flip door Puerta basculante	MDP	0,600 x 0,201 x 0,015	2
202885	Painel inferior giratório The bottom panel Panel inferior	MDP	1,260 x 0,450 x 0,015	1
202886	Painel superior giratório Superior panel Panel superior	MDP	1,260 x 0,360 x 0,015	1
202887	Apoio da bancada Support from the bench Apoyo desde el banquillo	MDP	1,282 x 0,081 x 0,015	1
202888	Apoio de parede Support of the wall Apoyo de la pared	MDP	1,222 x 0,058 x 0,015	1
202889	Tampo Cover Tapa	MDP	1,820 x 0,335 x 0,015	1
202890	Fundo inferior Lower fund Fondo inferior	MDP	1,815 x 0,185 x 0,003	1
202891	Fundo intermediário Intermediate fund Fondo intermedio	MDF	1,815 x 0,147 x 0,003	1
202892	Fundo superior lateral Bottom side top Lado inferior top	MDF	0,860 x 0,264 x 0,003	2
1.05.02.0061	Prateleira Shelf Estante	Vidro	0,229 x 0,163 x 0,005	4

ACESSÓRIOS | ACCESSORIES | ACESORIOS

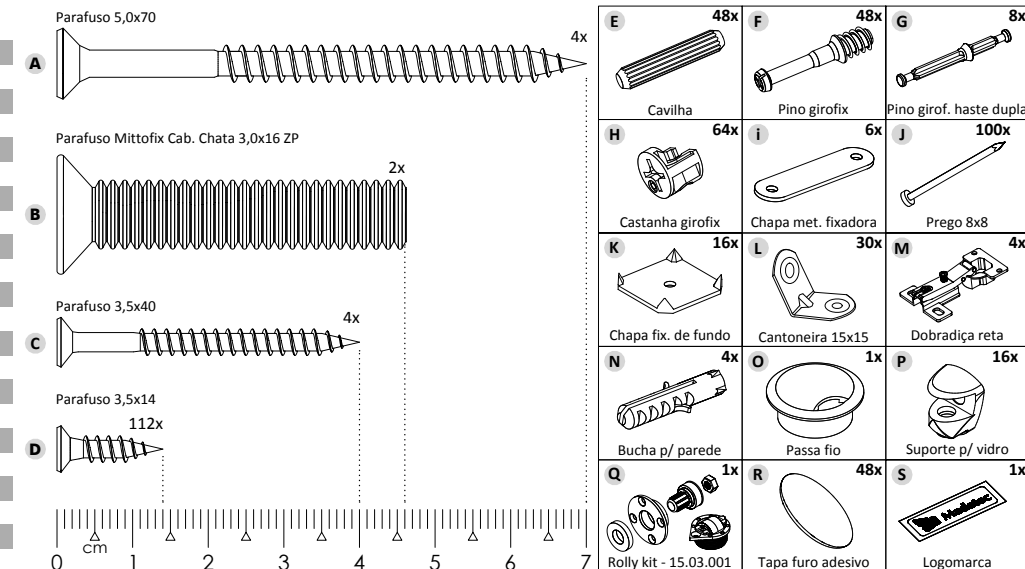

1º PASSO | PASS | PASO

PEÇAS
PIECES
PIEZAS

S.M.	C.P.
01	202871
02	202876
03	202877
04	202877
05	202876
06	202872
07	202878
08	202879
09	202879
10	202878
11	202889
12	202880
13	202881
14	202887
15	202881
16	202880
17	202875

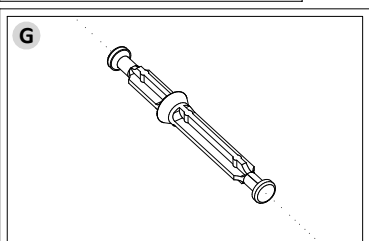
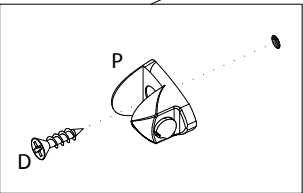
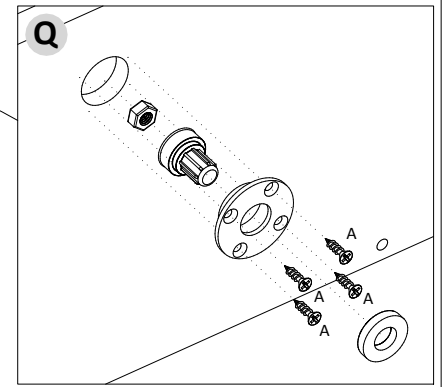
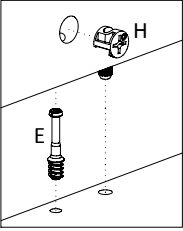

LADO SUPERIOR
UPPER SIDE
PARTE SUPERIOR

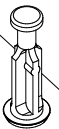

LADO INFERIOR
BOTTOM SIDE
LADO INFERIOR

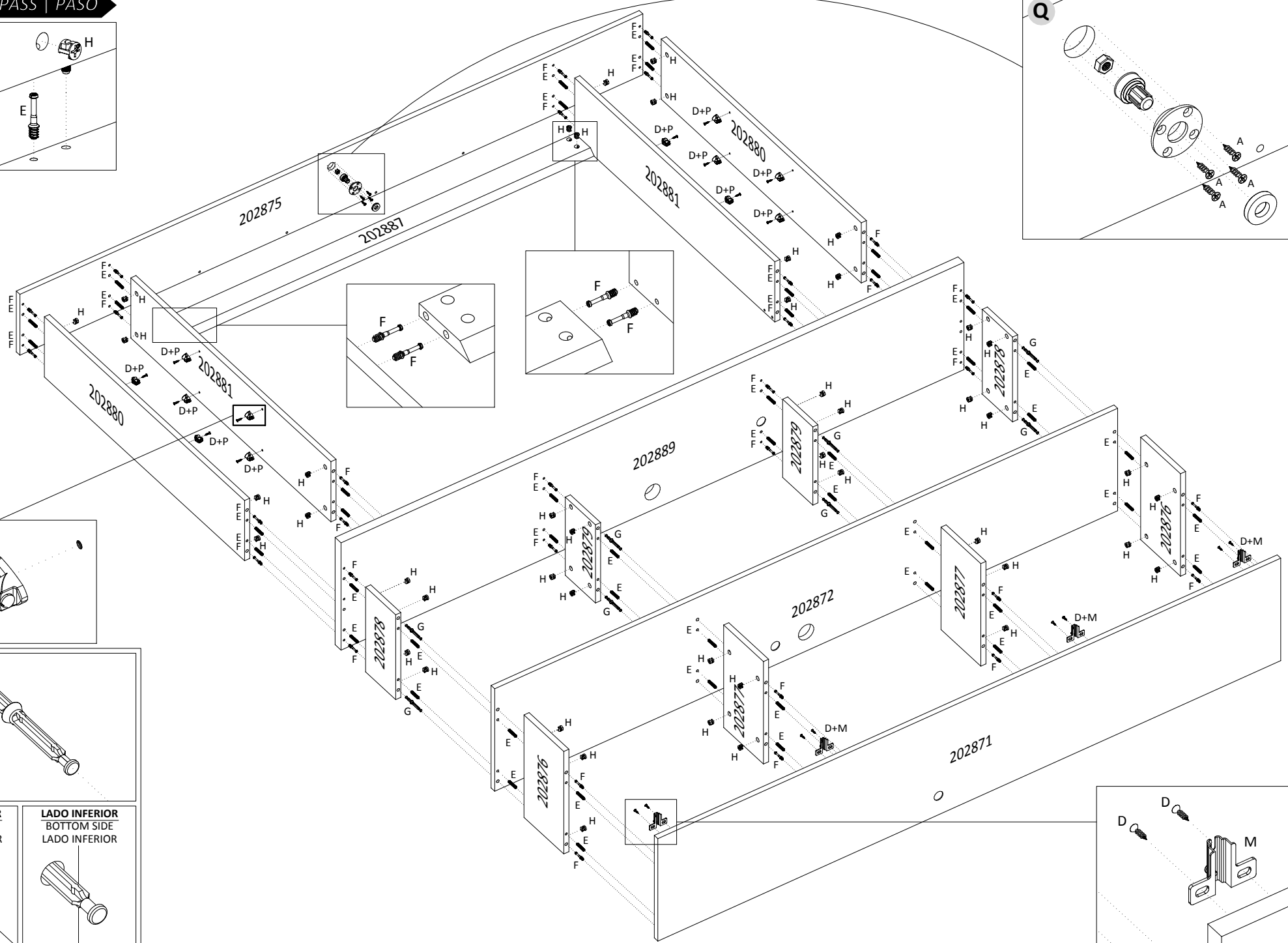
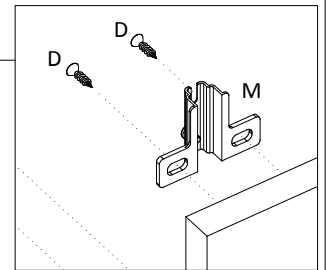
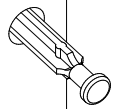

2º PASSO | PASS | PASO

PEÇAS
PIECES
PIEZAS

S.M.	C.P.
01	202884
02	202884

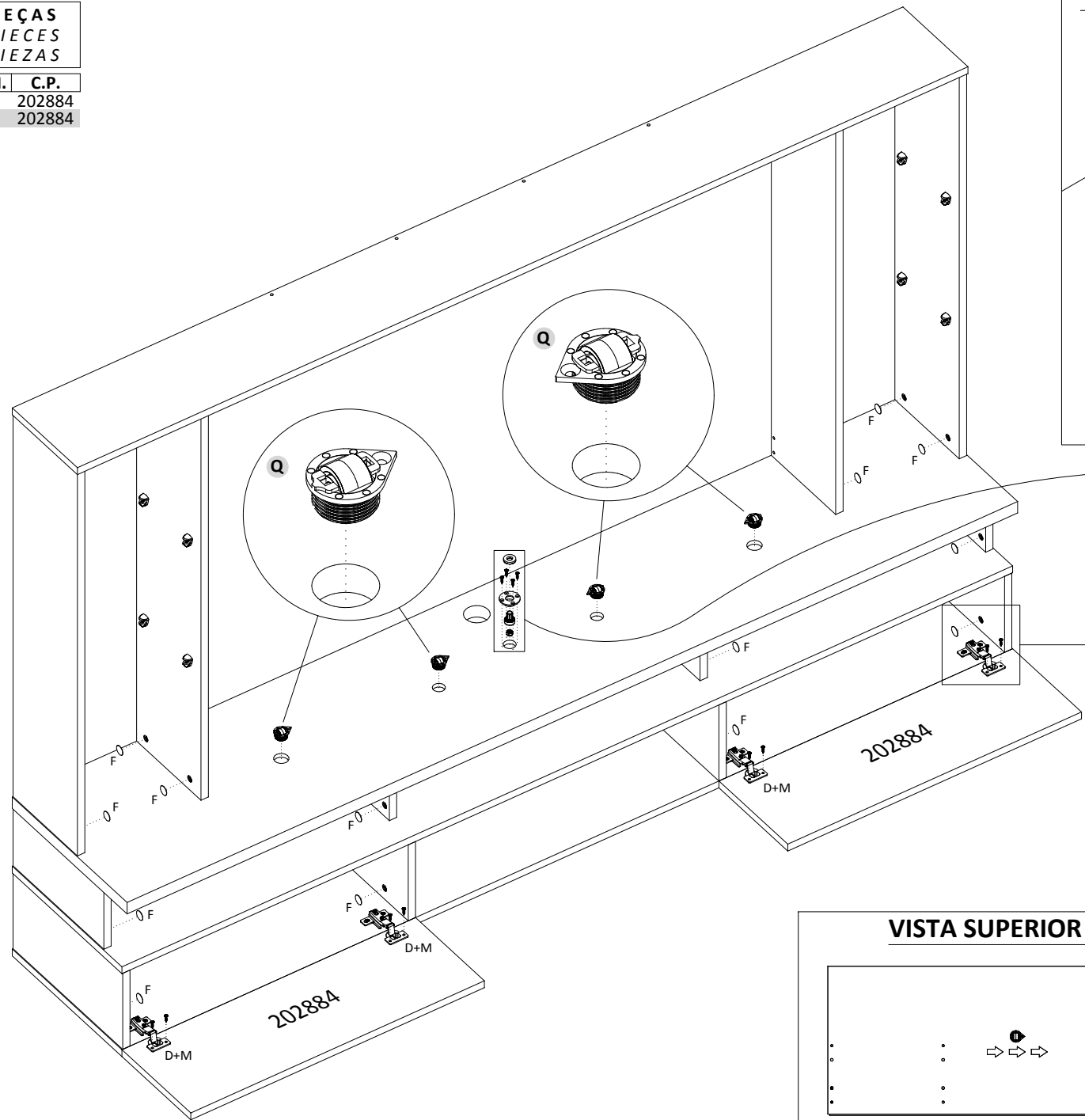

ATENÇÃO! | CAUTION! | ATENCIÓN!

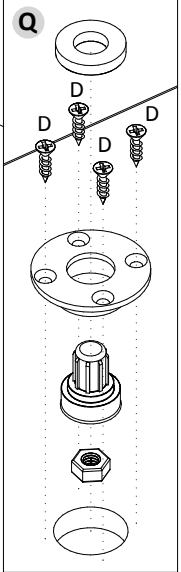
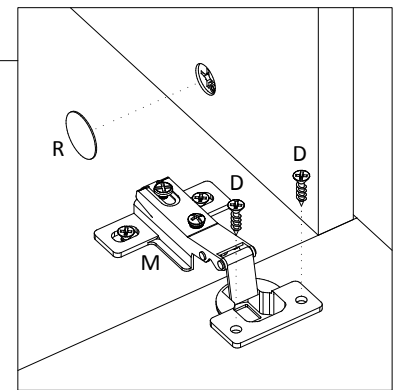
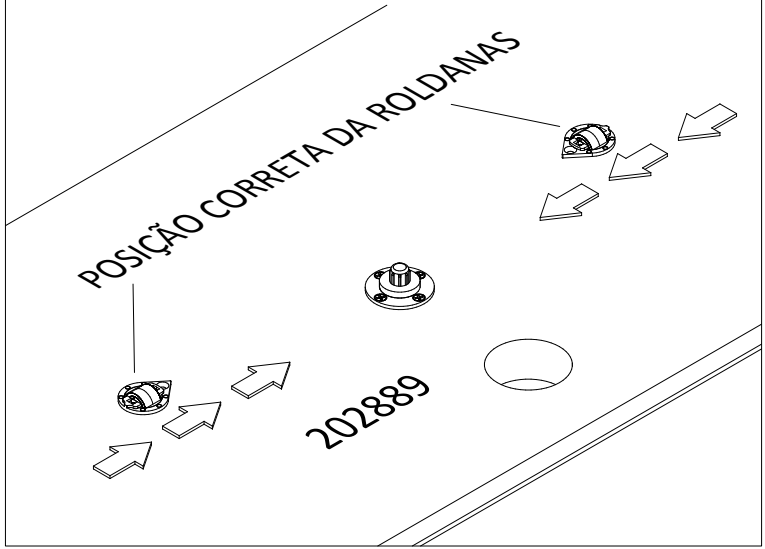

VISTA SUPERIOR DO TAMPO COM AS ROLDANAS FIXADAS

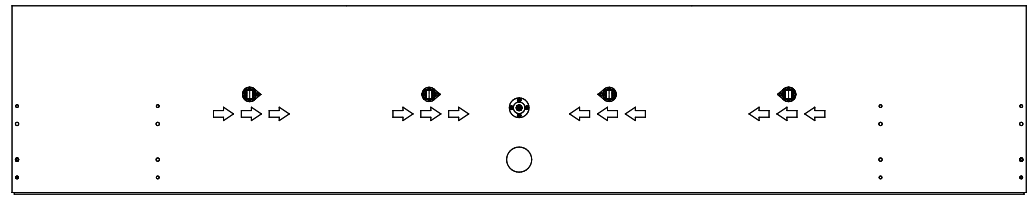

3º PASSO | PASS | PASO

PEÇAS
PIECES
PIEZAS

S.M.	C.P.
01	202873
02	202882
03	202883
04	202882
05	202874

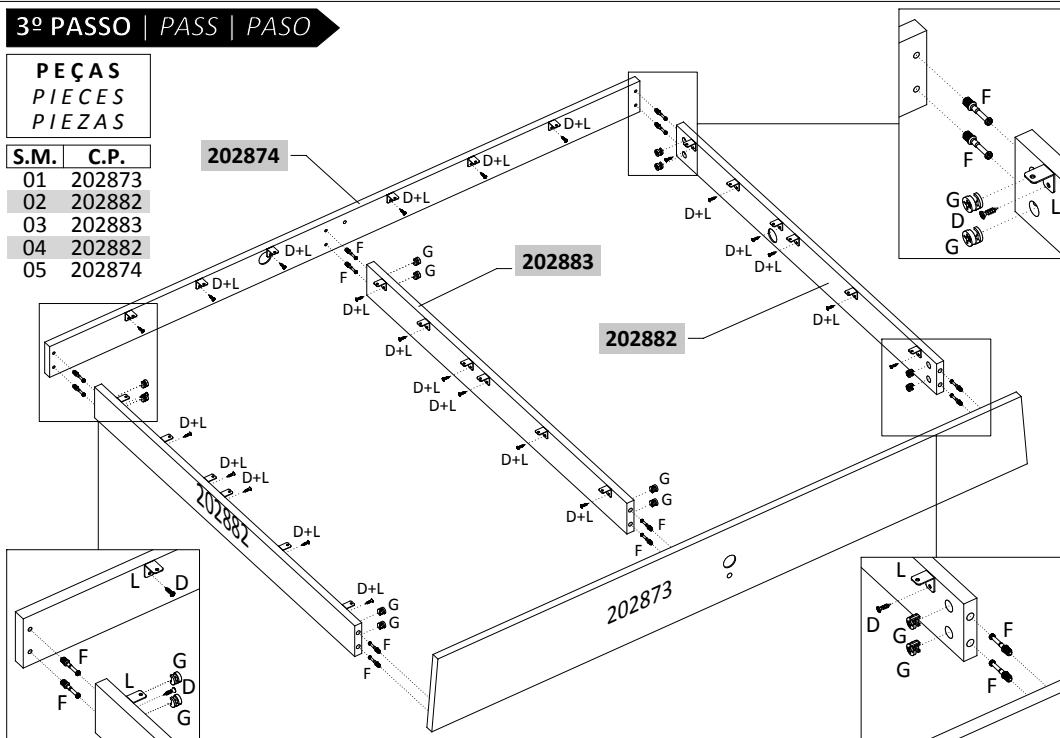

4º PASSO | PASS | PASO

PEÇAS
PIECES
PIEZAS

S.M.	C.P.
01	202885
02	202886

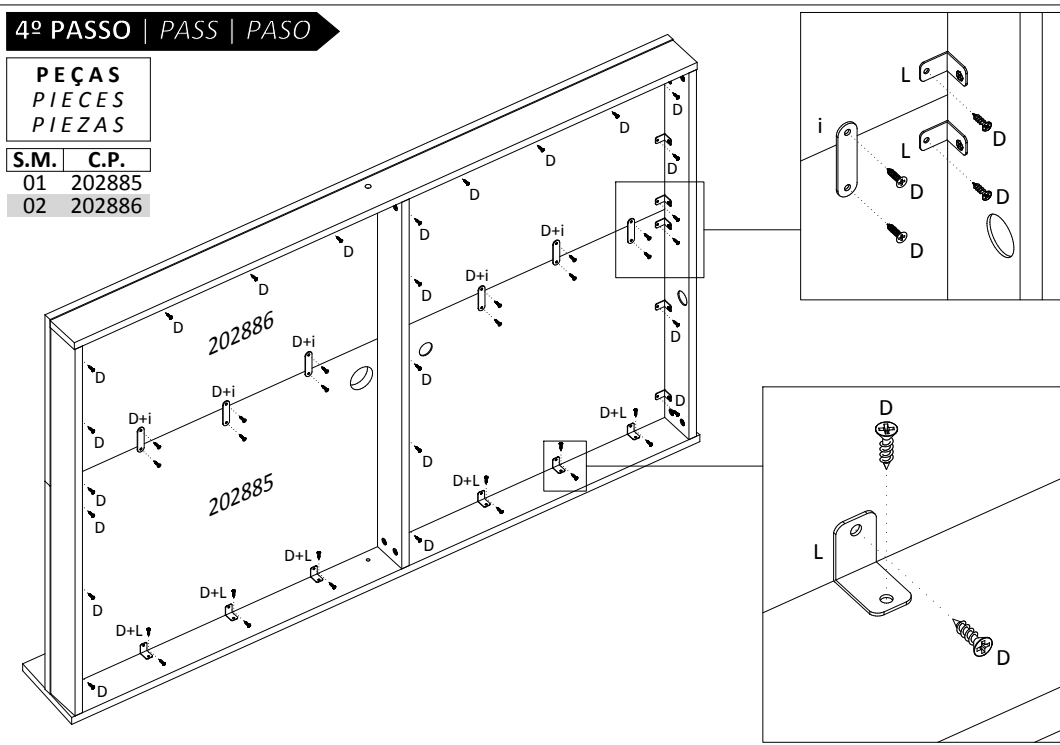

5º PASSO | PASS | PASO

PEÇAS
PIECES
PIEZAS

S.M.	C.P.
01	202890
02	202891
03	202892
04	202892

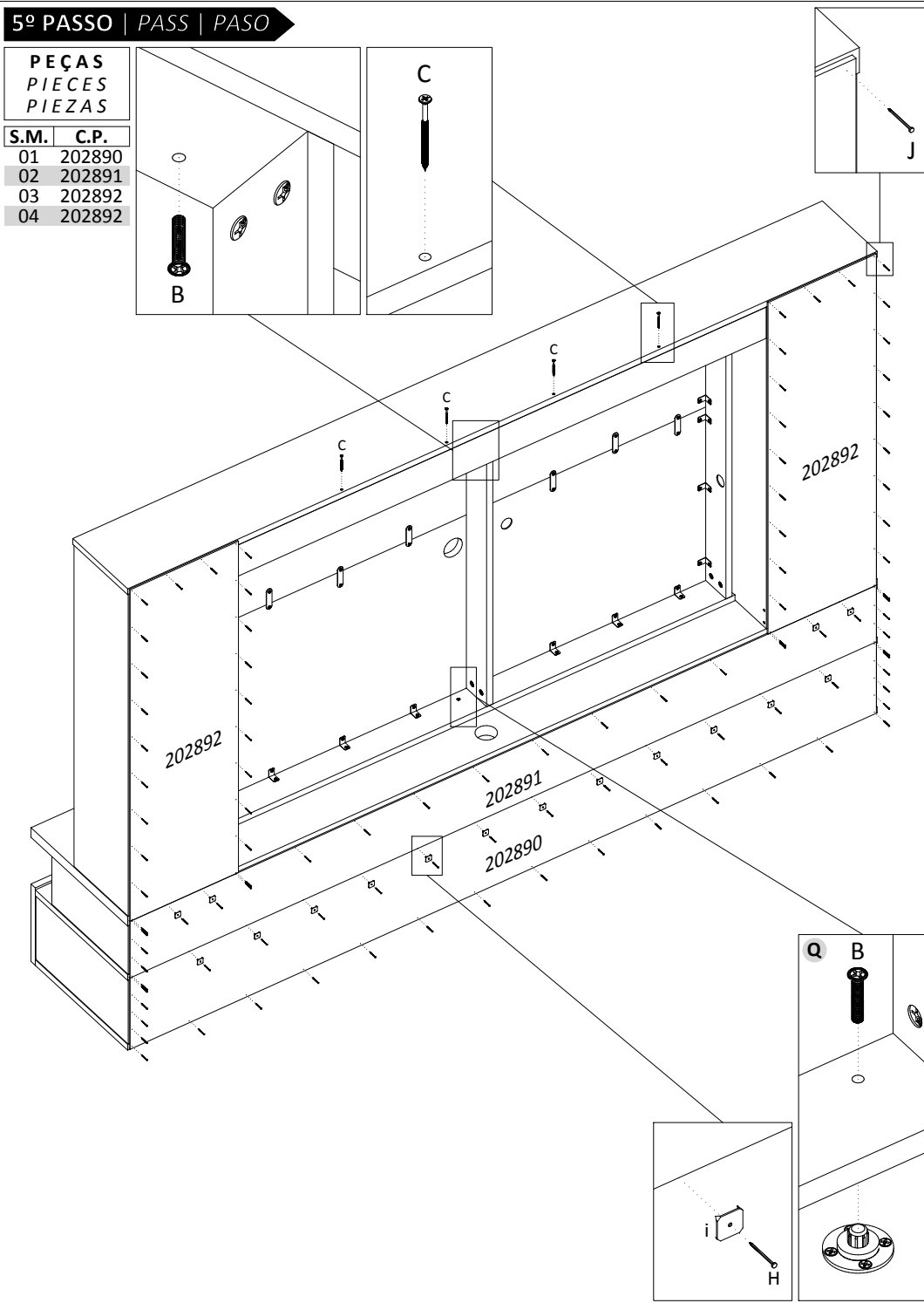

6º PASSO | PASS | PASO

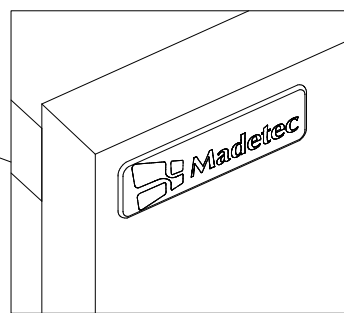
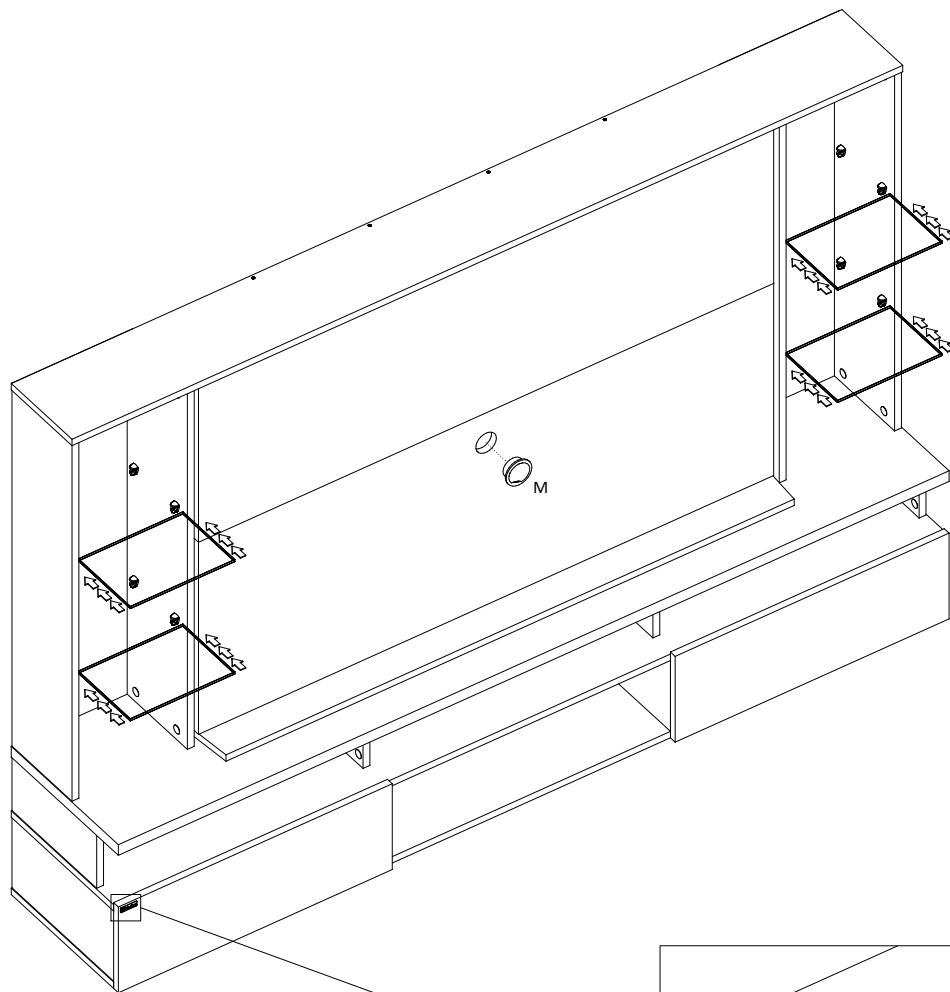

7º PASSO | PASS | PASO

PEÇAS
PIECES
PIEZAS

S.M.	C.P.
01	202888

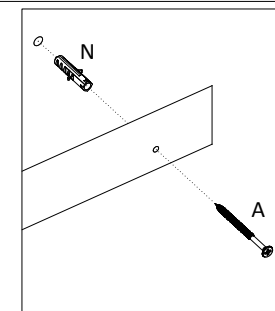

Parede | Wall | Pared

202888

Medida até o furo
Measure until the hole
Mide hasta que el agujero

1,435 m

0,70 m

Madetec

Este produto
deve ser usado
com a TV fixada
no painel.