

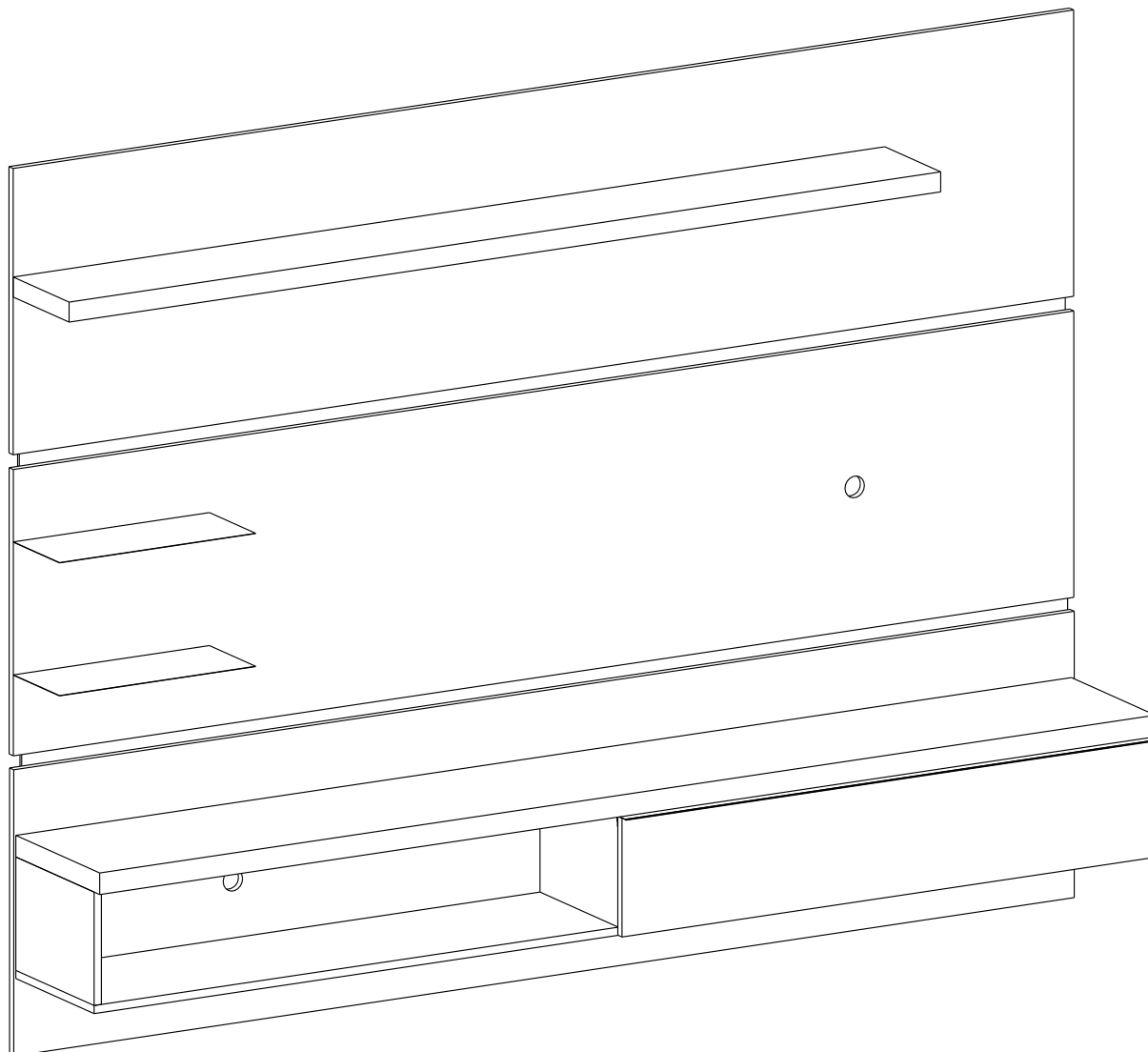

Criatividade ao seu Estilo

HOME SUSPENSO ORES 2.2



MANUAL DE MONTAGEM ASSEMBLY INSTRUCTIONS INSTRUCCIONES DE MONTAJE

COMPRIMENTO: 2200mm
ALTURA: 1620mm
PROFUNDIDADE: 330mm

LENGTH: 2200mm
HEIGHT: 1620mm
DEPTH: 330mm

LONGITUD: 2200mm
ALTURA: 1620mm
PROFUNDIDAD: 330mm

FERRAMENTAS

Recomendamos o uso de chave de fenda Philips, martelo e parafusadeira ao montar o móvel

We recommend using screwdriver Philips, hammer and screwdriver to assemble mobile

Recomendamos el uso de un destornillador Philips, martillo y un destornillador para montar o móvil

PAPEL RECICLADO

 RECYCLED PAPER

PAPEL RECICLADO

REVISÃO/REVIEW/COMENTÁRIO
OO - 07/11/2016

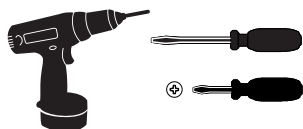

Fone/Fax: (43) 3274 - 9900 - E-Mail: assistencia@hbmoveis.com.br

ARAPONGAS - PARANÁ - BRASIL

www.hbmoveis.com.br



HB e você
amigos do
meio-ambiente!



IMAGEM IMAGE IMAGEN	FERRAGENS/ACESSÓRIOS	HARDWARE/ACESSORIES	HARDWARE/ACESSORIOS
A 	16 Cavilha 80 X 30	Pin 80 X 30	Perno 80 X 30
B 	03 Dobradiça Reta	Hinge Mug	Taza De Bisagra
C 	03 Dobradiçacalço 1mm	Hinge Shim	Bisagra Shim
D 	12 Girofix Pino	Mini Fix Screw	Minifix Tornillo
E 	12 Girofix Tambor	Mini Fix Round Nut	Tambor Minifix
F 	05 Parafuso 35 X 40mm	Screw 35 X 40mm	Tornillo 35 X 40mm
G 	12 Parafuso Flangeado 40x14mm	Flanged Screw 40x14mm	Tornillo Con Reborde 40x14mm
H 	17 Bucha De Parede	Wall Bushing	Pasamuros
I 	02 Passa Fio 40mm	Pass Wire 40mm	Pass Alambre
J 	12 Girofix Tampa	Minifix Cover	Minifix Cubierta
K 	01 Puxador De Alumínio	Handle Aluminium	Mango Alumínio
L 	03 Parafuso 35 X 12mm	Screw 35 X 12mm	Tornillo 35 X 12mm
M 	17 Parafuso 60 X 75mm	Screw 60 X 75mm	Tornillo 60 X 75mm
N 	10 Parafuso 50 X 60mm	Screw 50 X 60mm	Tornillo 50 X 60mm
O 	33 Parafuso 40 X 25mm	Screw 40 X 25mm	Tornillo 40 X 25mm
P 	20 Parafuso 40 X 20mm	Screw 40 X 20mm	Tornillo 40 X 20mm
Q 	32 Cavilha 80 X 20	Pin 80 X 20	Perno 80 X 20
R 	04 Suporte Prateleira Ts	Support Self Ts	Ts Estanterías Apoyo
S 	01 Kit Led	Led Kit	Kit Led
T 	02 Cola	Glue	Pegamento
U 	02 Vidro	Glass	Vidrio

Parabéns, você adquiriu um produto da HB MÓVEIS com qualidade e estilo que a empresa oferece

ATENÇÃO:

- * Recomendamos que montagem seja realizada por um montador profissional
- * No caso de Assistência técnica indicar corretamente nome do produto, nº da peça e cor.

Cuidados com a limpeza do produto:

- * Utilizar pano seco e macio e nunca aderir o uso de produtos abrasivos.

Congratulations, you got a HB MOBILE product with quality and style that the company offers

HEADS UP:

- * We recommend that assembly is performed by a professional fitter
- * In the case of thecnical assistance correctly indicate product name, paragraph of the piece and color.

Care cleaning product:

- * Use dry, soft cloth and never join using abrasive products.

Felicitaciones, usted tiene un producto HB MÓVIL con calidad y estilo que ofrece la empresa

AVISO:

- * Se recomienda que el montaje se realiza por un montador profesional
- * En el caso de la asistencia técnica indica correctamente el nombre del producto, el punto de la pieza y el color.

Cuidado producto de limpieza:

- * Utilice un paño seco, suave y nunca unirse a usar productos abrasivos.

COD.	QTDE	PEÇA	PART	PARTE
01	01	Base	Base	Base
02	03	Lateral esq/dir/div	Side Left/Right/Divisoria	Lado Izquie/Dere/Tabique
03	01	Tampo	Cover	Cubierta
04	01	Painel Inferior	Lower Panel	El Panel Inferior
05	01	Painel Central	Central Panel	Panel Central
06	01	Painel Superior	Top Panel	El Panel Superior
07	01	Prateleira	Shelf	Estante
08	01	Porta	Door	Puerta
09	02	Régua Painel Sup/Cent	Ruler Panel Sup/Cent	Regla Grupo Sup/Cent
10	02	Régua parede Sup/Cent	Ruler Wall Sup/Cent	Regla Pared Sup/Cent
11	02	Régua Painel Inferior	Ruller Bottom Panel	Regla Panel Inferior
12	02	Régua Parede Inferior	Lower Ruler Wall	Regla Bajar Pared
13	08	Calço Lateral Paineis	Chock Side Panels	Paneles Laterales de Calzo
14	02	Régua Decorativa	Ruler Decorative	Gobernante Decorativo
15	06	Calço Paineis	Shim Panels	Paneles de la calza
16	02	Gabarito de Montagem	Jig Assembly	Asamble de la plantilla

1° PASSO/STEP/PASO

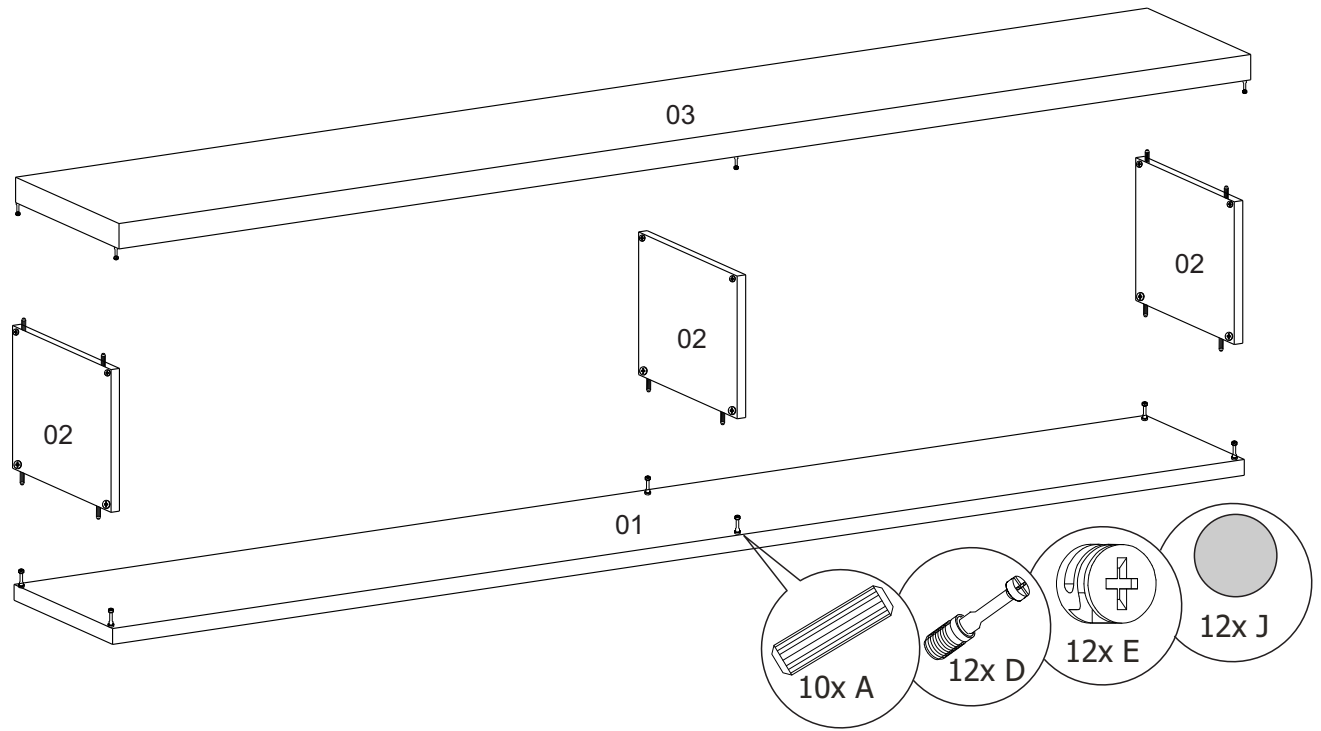

2° PASSO/STEP/PASO

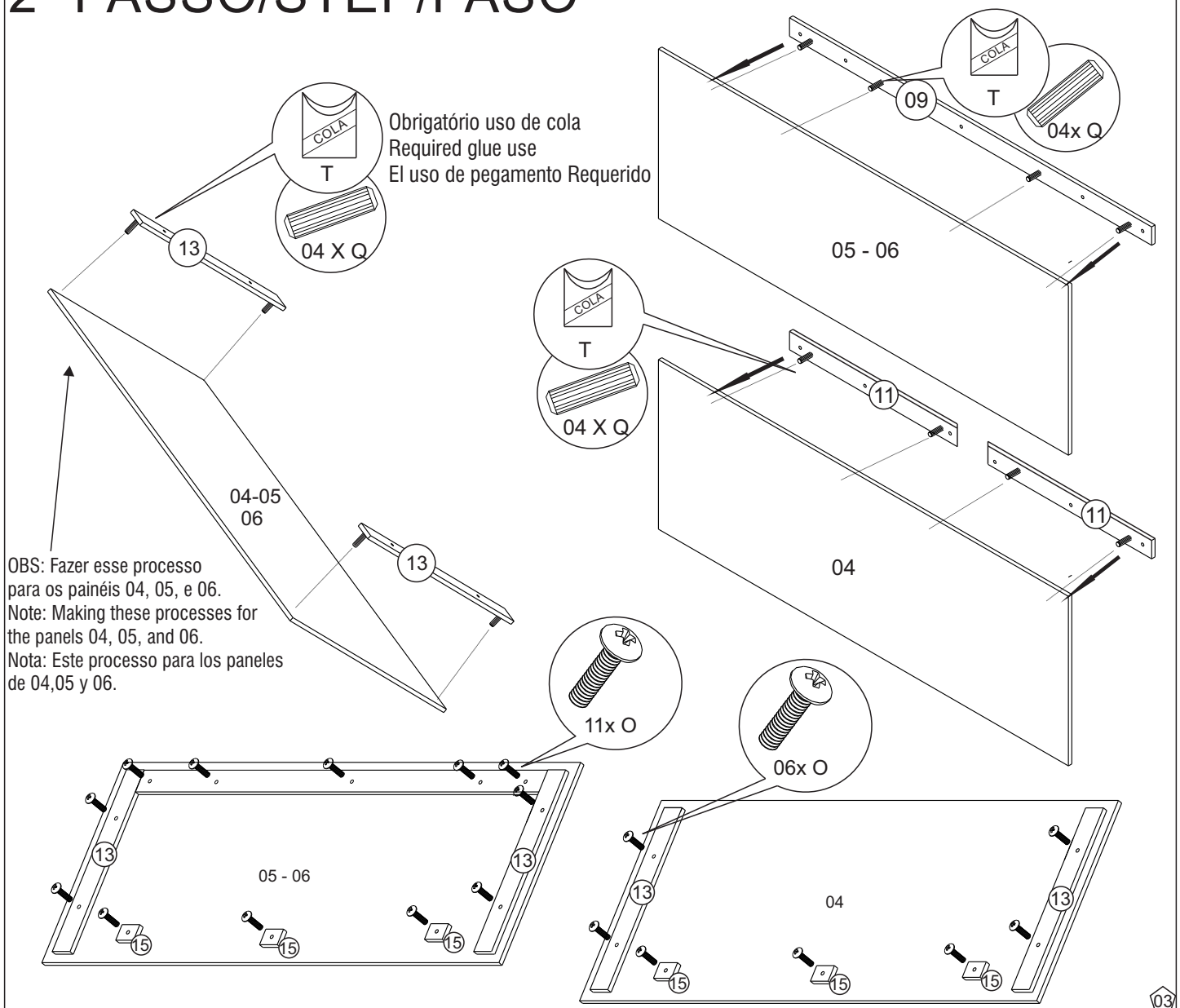

3° PASSO/STEP/PASO

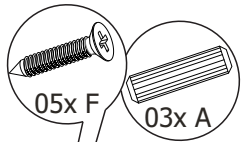

Obs: Parafusos irão passar fixando três peças, travessas do painel, painel e tampo.

Note: The screws will spend fixing three pieces, sleepers panel, panel and top.

Obs: Los tornillos de fijación se pasan tres piezas , el panel durmientes, paneles y superior

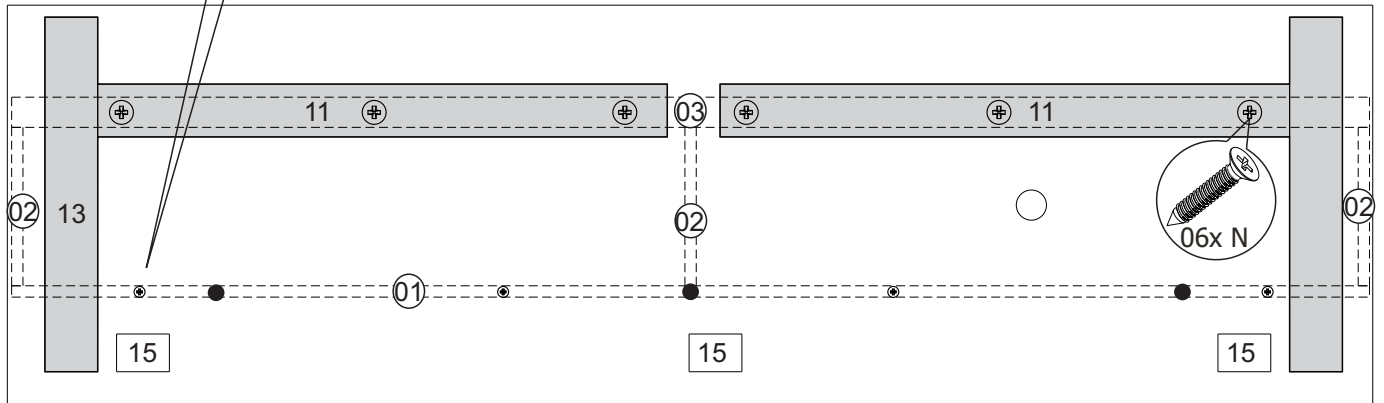

4° PASSO/STEP/PASO

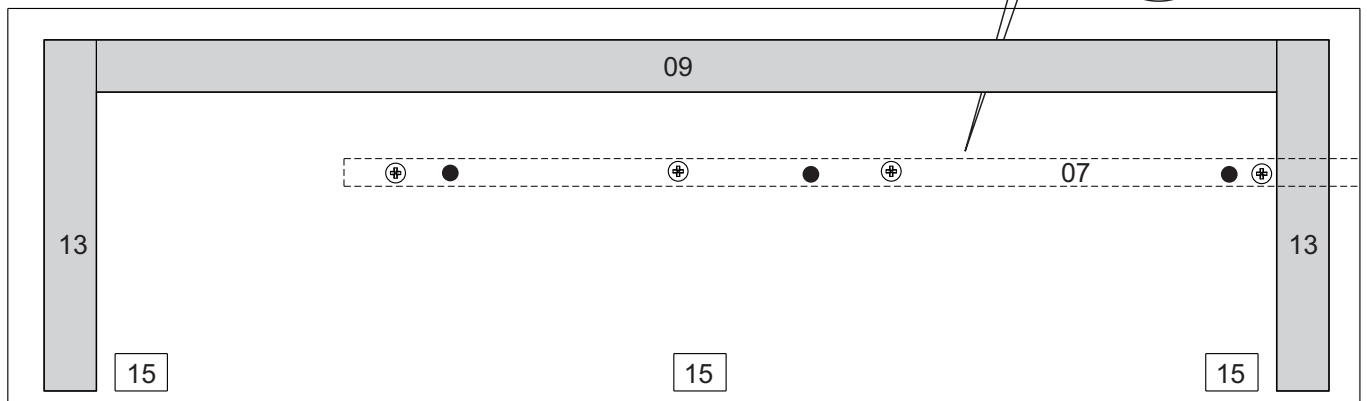
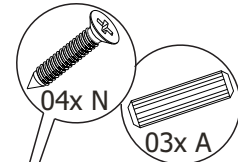

5° PASSO/STEP/PASO

Obs: Repetir processo para os painéis 05 e 06.

Note: Repeat process for panels 05 and 06.

Obs: Repita el proceso para los paneles 05 y 06.

2x

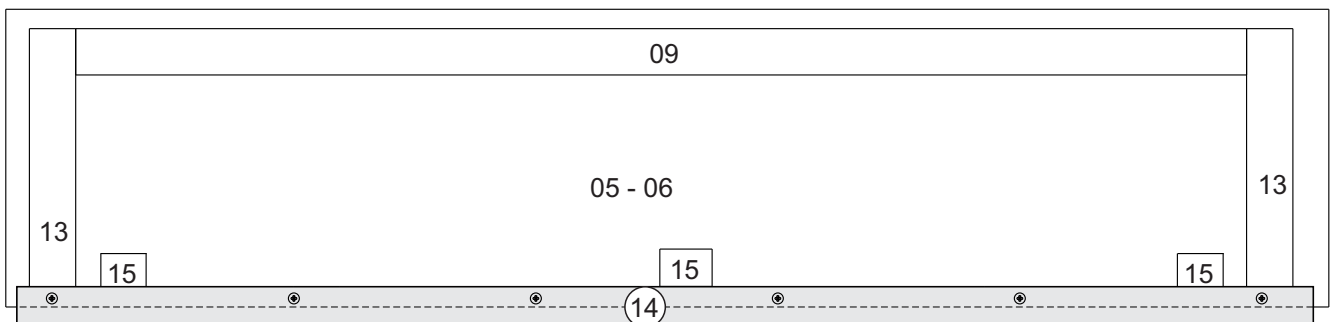

6° PASSO/STEP/PASO

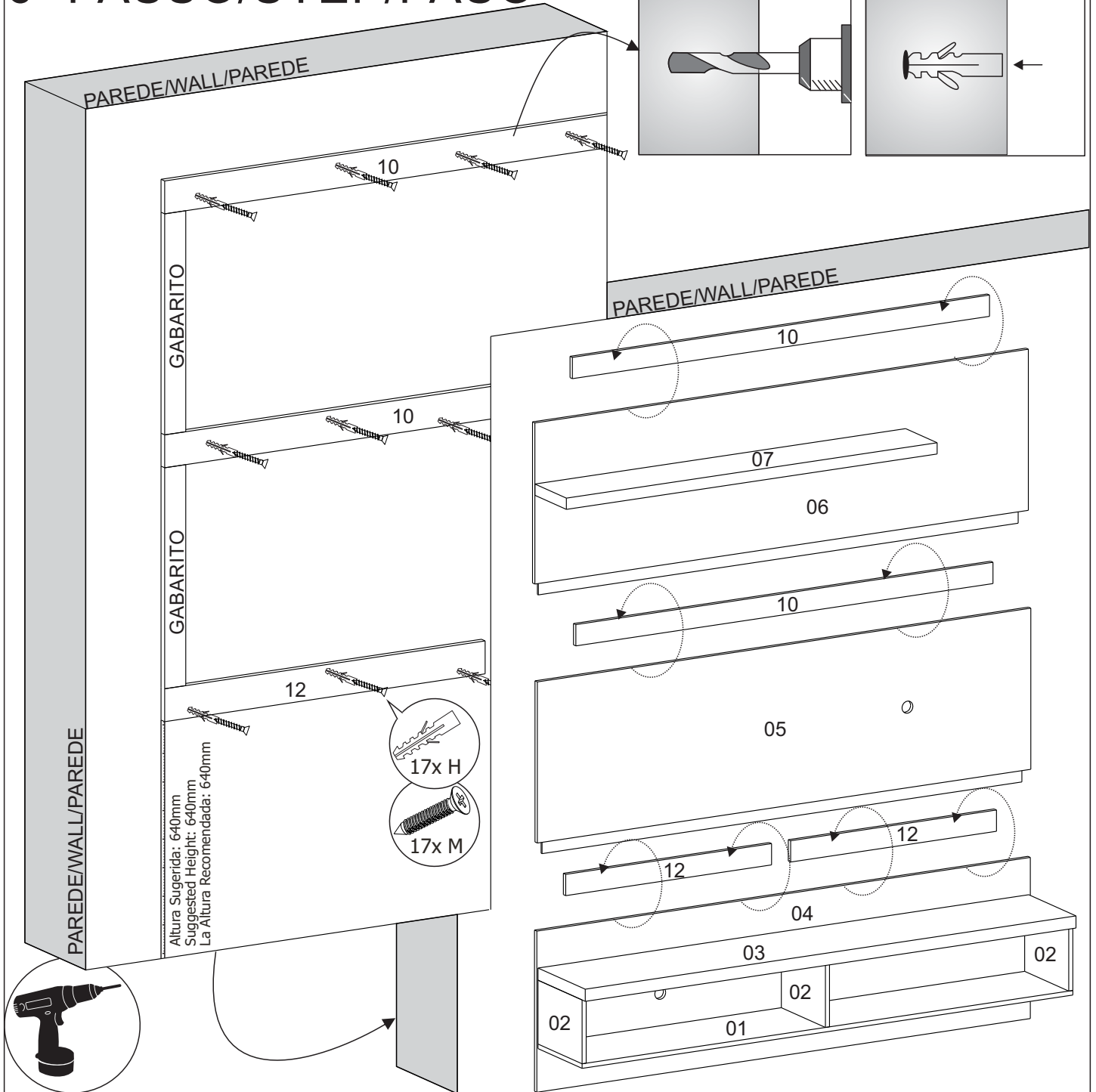

7° PASSO/STEP/PASO

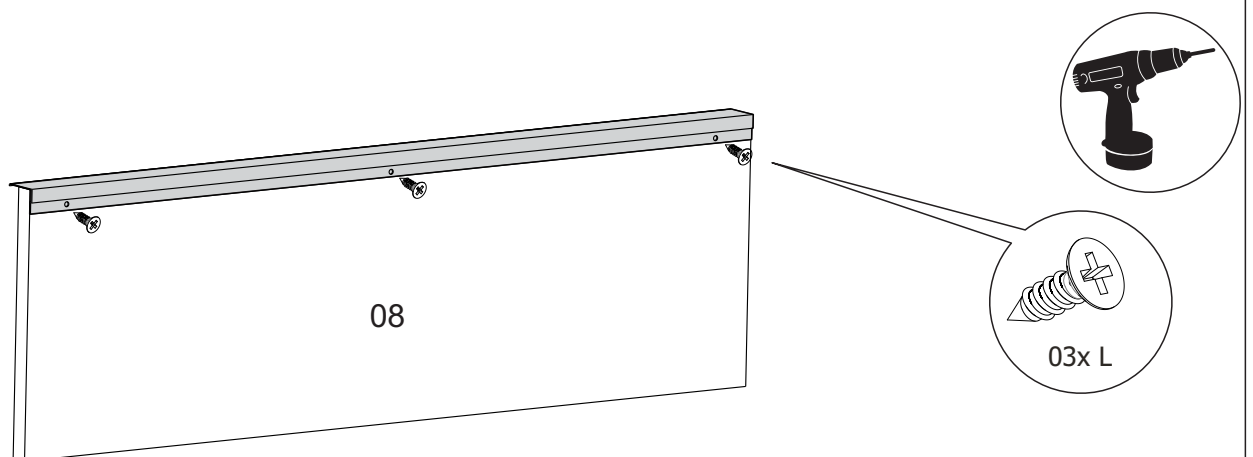

8° PASSO/STEP/PASO

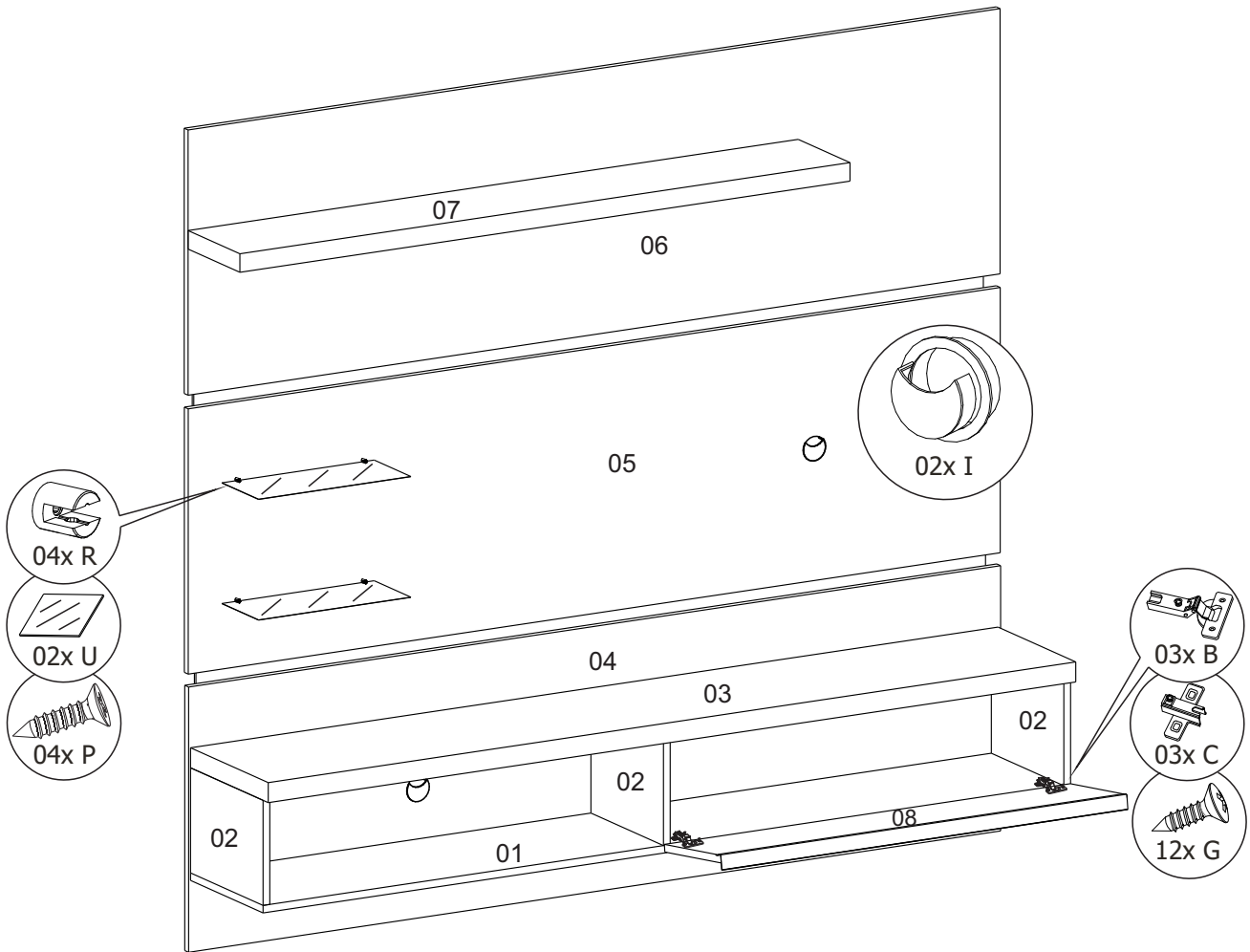

8° PASSO/STEP/PASO

