

Produto Montado  
Producto final  
Assembled

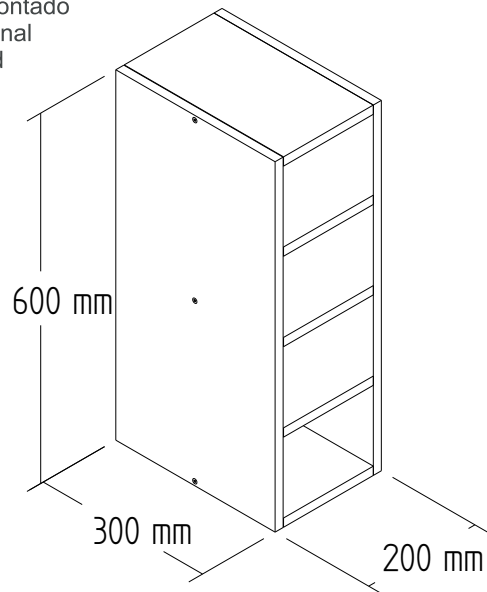

1º

**D** BUCJA BUJE BUCHING 12 uni **A** Parafuso Tornillo Screw 4X45 6 uni

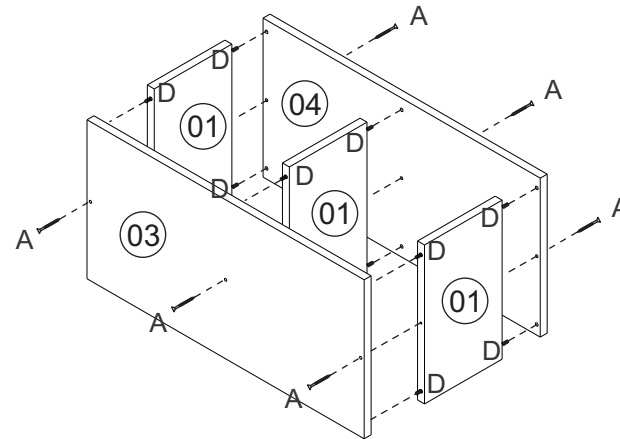

2º

**H** Frego Clavo Nail 32 uni

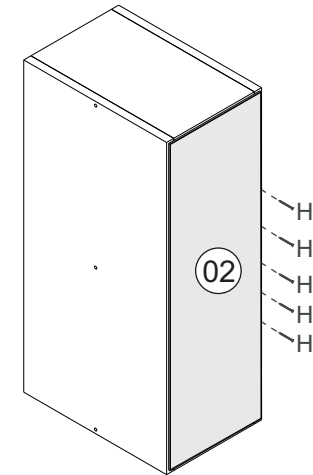

3º

Fixação parede  
Fixed in the wall

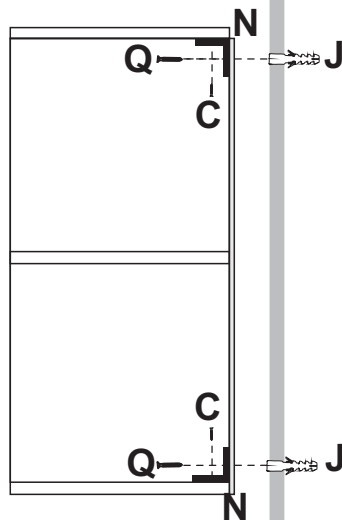
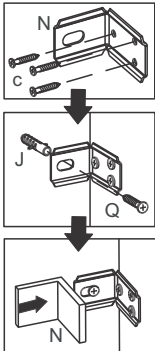

**ATENÇÃO!!!! montadores e consumidores**

\* Para limpar o móveis utilize somente um pano úmido (umedecido em água pura ou água com sabão neutro). Depois, passe um pano seco. Evite a umidade excessiva.

\* Evite usar álcool, água sanitária, detergente e outros produtos químicos, mesmo diluídos em água. Não utilize produtos abrasivos de nenhuma espécie

**ATENCIÓN!!!! montadores e consumidores**

\* Para limpiar el mueble utilice solamente un paño húmedo (humedecido con agua limpia o con un jabón suave).

Acontinuación, utilice un paño seco. Evite el exceso de humedad.

\* Evite uso de alcohol, hipoclorídoro solución basada, detergente y otros productos químicos, mismo diluídos en agua. No utilice productos abrasivos de ningún tipo.

**ATTENTION!!!! assemblers and consumers**

\*To clean the furniture, use only a damp cloth (humidify it only in pure water ou water and neutral soap).After, use a dry cloth.Avoid excessive humidity.

\*Avoid using alcohol, bleach, detergent and other chemical products, even diluted in water. Do not use any kind of abrasive cleaning agents to clean the furniture.

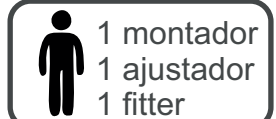
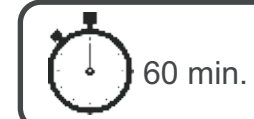

The use of such products may jeopardize the final characteristics of the furniture.

Ferramenta necessárias  
Necessary tools  
Herramientas necesarias





# Ferragens/ Herrajes/ Hardware

## escala (1:1)

| LEGENDA  | DESCRIÇÃO/DESCRIPCIÓN/DESCRIPTION  | CÓDIGO | QUANT.    |
|----------|--|--------|-----------|
| <b>A</b> | <br>PARAFUSO/TORNILLO/SCREW 4X45                            | 07653  | <b>06</b> |
| <b>H</b> | <br>PREGO/CLAVO/NAIL 10X10                                  | 01330  | <b>32</b> |
| <b>D</b> | <br>CAVILHA/TARUGO/DOWEL 6X30 MM                            | 01211  | <b>14</b> |
| <b>Q</b> | <br>PARAFUSO/TORNILLO/SCREW 6X50                            | 03827  | <b>02</b> |
| <b>I</b> | <br>PARAFUSO DE UNIÃO/TORNILLO PARA UNIÓN<br>BOLT FOR UNION | 01495  | <b>02</b> |
| <b>J</b> | <br>BUCHA/BUJE/BUCHING                                    | 01311  | <b>02</b> |
| <b>C</b> | <br>PARAFUSO/TORNILLO/SCREW 4X16                          | 01319  | <b>04</b> |

## escala (N/A)

| LEGENDA  | DESCRIÇÃO/DESCRIPCIÓN/DESCRIPTION  | CÓDIGO | QUANT.    |
|----------|--|--------|-----------|
| <b>F</b> | <br>COLA/PEGAMENTO/GLUE                   | 01213  | <b>01</b> |
|          | <br>ETIQUETA LOGO DECIBAL/LABEL DECIBAL   | 01312  | <b>01</b> |
| <b>N</b> | <br>SUPORTE AÉREO/APOYO AÉREO/AIR SUPPORT | 03828  | <b>02</b> |

## Relação de Peças/ Relación de Piezas/Parts List

| Nº | CÓDIGO/ CODE | DESCRIÇÃO/DESCRIPCIÓN/DESCRIPTION    | QTD/ CANT | VOL. |
|----|--------------|--------------------------------------|-----------|------|
| 1  | 0511365      | BASE 298X168X15MM P                  | 3,00      | 1    |
| 2  | 0511366      | COSTA/REVÉS/BACK 590X190X3,2 MM P    | 1,00      | 1    |
| 3  | 0511367      | LATERAL/LATERAL/SIDE 600X298X15 MM P | 1,00      | 1    |
| 4  | 0511367      | LATERAL/LATERAL/SIDE 600X298X15 MM P | 1,00      | 1    |

