

5202 - MÓDULO FORNO

Manual de Montagem
 Assembly Instructions
 Instrucción de Montaje

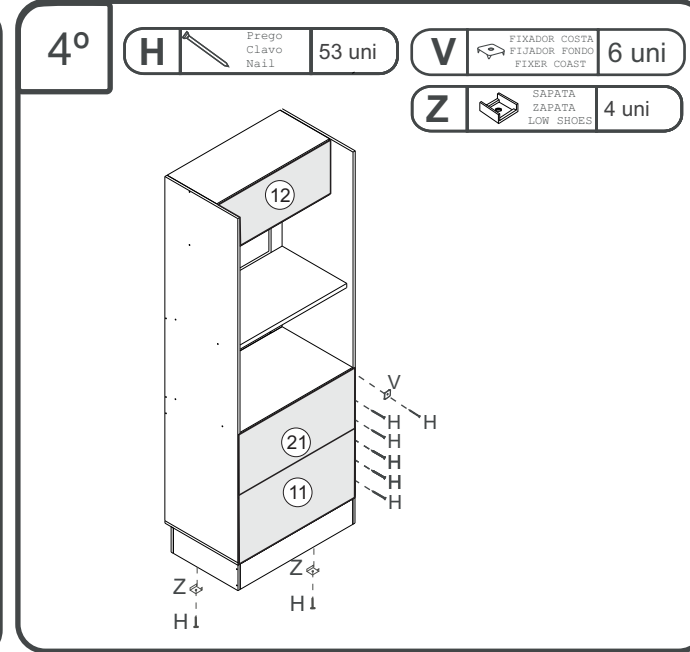

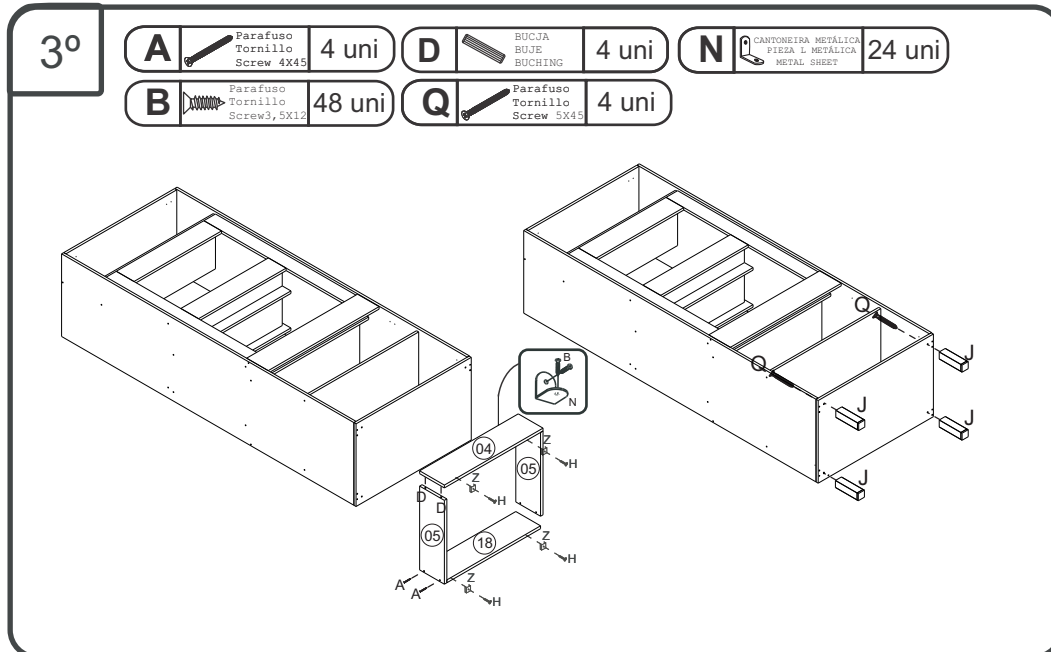
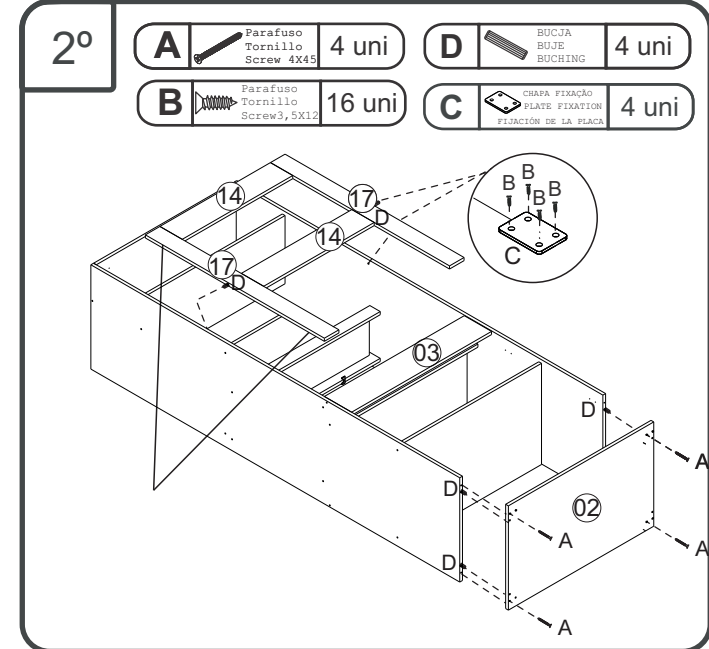
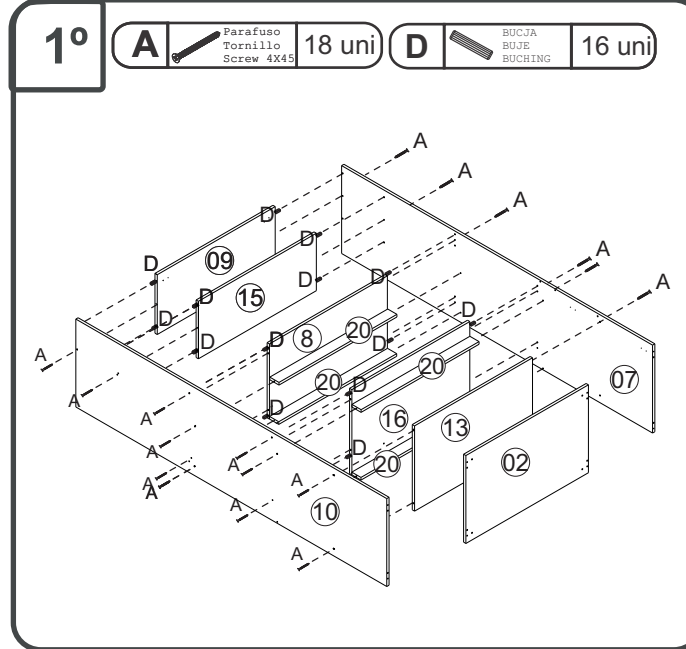
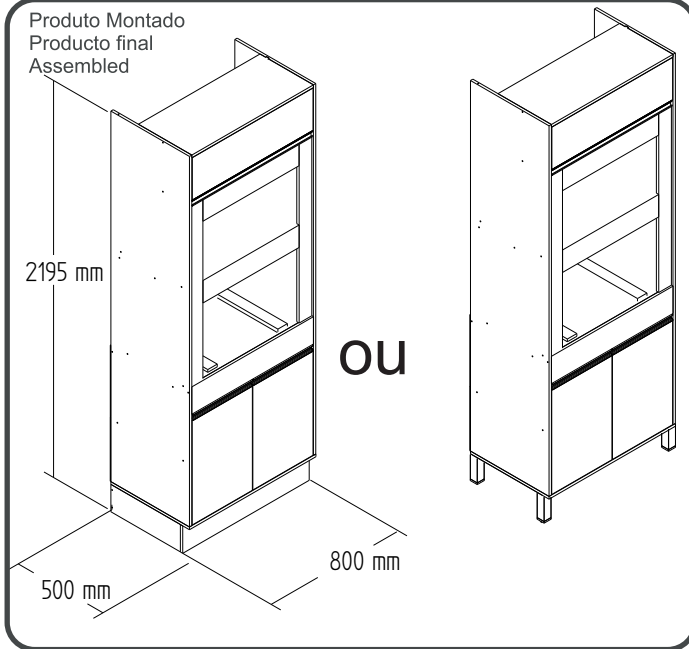
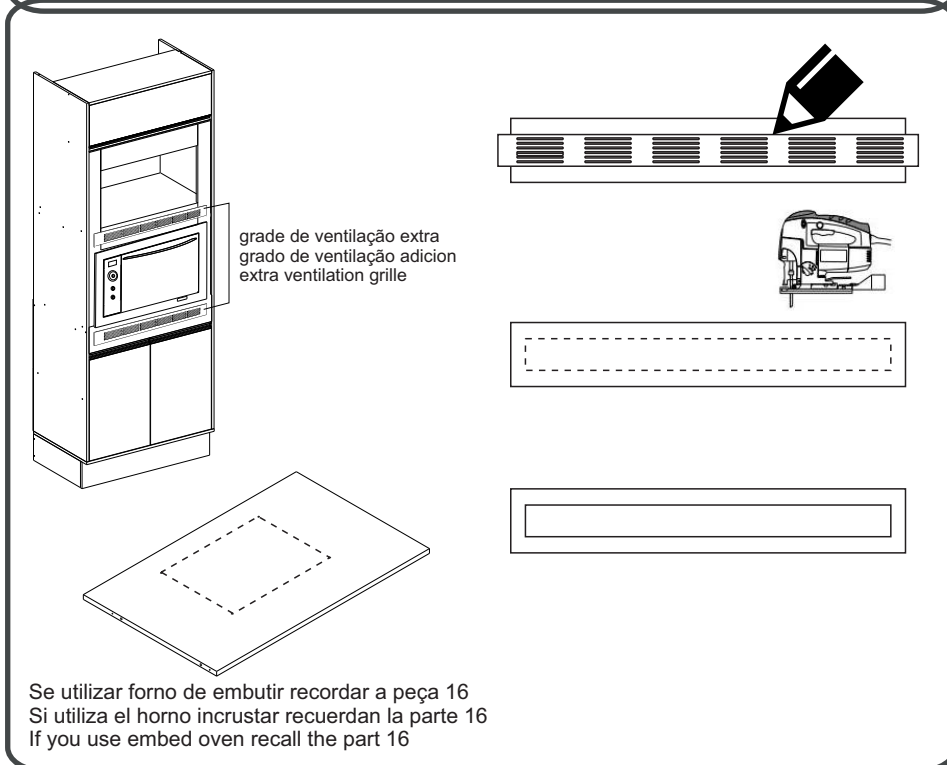
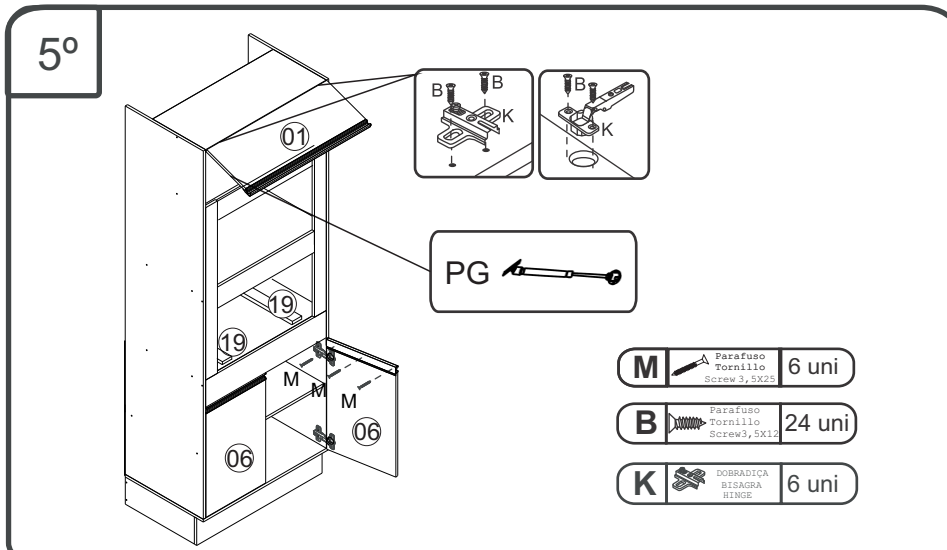

Relação de Peças/ Relación de Piezas/Parts List

N°	CÓDIGO/ CODE	DESCRIÇÃO/ DESCRIPCIÓN/ DESCRIPTION	QTD/ CANT	VOL.
1	0511140	PORTA/ PUERTA/ DOOR 766X233X15MM	1,00	1
2	0511152	BASE 800X497X15MM P	1,00	2
3	0511156	TRAVESSA/ TRAVIESA/ TRAVERSE 770X150X15MM	1,00	1
4	0511161	RODAPÉ/ ZÓCALO/ BASEBOARD 800X150X15MM P	1,00	1
5	0511162	RODAPÉ/ ZÓCALO/ BASEBOARD 440X150X15MM P	2,00	2
6	0511164	PORTA/ PUERTA/ DOOR 573X381X15MM	2,00	1
7	0511193	LATERAL/ LATERAL/ SIDE 2030X497X15 MM P	1,00	1
8	0511195	BASE 770X440X25MM P	1,00	2
9	0511196	BASE 770X338X15MM P	1,00	2
10	0511197	LATERAL/ LATERAL/ SIDE 2030X497X15 MM P	1,00	1
11	0511198	COSTA/ REVÉS/ BACK 792X355X3,2MM	1,00	2
12	0511199	COSTA/ REVÉS/ BACK 770X278X2,8 MM P	1,00	2
13	0511201	PRATELEIRA/ ESTANTE/ SHELF 770X480X15MM	1,00	2
14	0511202	TRAVESSA/ TRAVIESA/ TRAVERSE 608X123X15MM	2,00	1
15	0511203	BASE 770X325X15MM P	1,00	1
16	0511205	BASE 770X482X15MM P	1,00	2
17	0511207	TRAVESSA/ TRAVIESA/ TRAVERSE 985X80X15MM	2,00	1
18	0511210	RODAPÉ/ ZÓCALO/ BASEBOARD 770X150X15MM P	1,00	1
19	0511818	TRAVESSA/ TRAVIESA/ TRAVERSE 467X60X15MM	2,00	1
20	0511813	TRAVESSA/ TRAVIESA/ TRAVERSE 770X60X15MM	4,00	1
21	0511604	COSTA/ REVÉS/ BACK 792X410X15MM	1,00	1

Ferramenta necessárias
Necessary tools
Herramientas necesarias

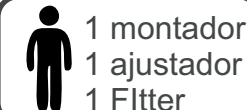
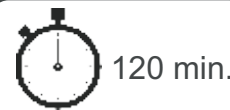

www.decibal.com.br

ATENÇÃO!!!! montadores e consumidores

* Para limpar o móveis utilize somente um pano úmido (umedecido em água pura ou água com sabão neutro). Depois, passe um pano seco.
Evite a umidade excessiva.
* Evite usar álcool, água sanitária, detergente e outros produtos químicos, mesmo diluídos em água. Não utilize produtos abrasivos de nenhuma espécie











ATENCIÓN!!!! montadores e consumidores

* Para limpiar el mueble utilice solamente un paño húmedo (humedecido con agua limpia o con un jabón suave).
Continuación, utilice un paño seco. Evite el exceso de humedad.
* Evite uso de alcohol, hipoclorídoro solución basada, detergente y otros productos químicos, mismo diluídos en agua. No utilice productos abrasivos de ningún tipo.

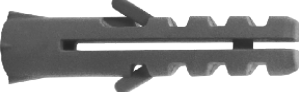
ATTENTION!!!! assemblers and consumers

* To clean the furniture, use only a damp cloth (humidify it only in pure water ou water and neutral soap).After, use a dry cloth.Avoid excessive humidity.
* Avoid using alcohol, bleach, detergent and other chemical products, even diluted in water. Do not use any kind of abrasive cleaning agents to clean the furniture.
The use of such products may jeopardize the final characteristics of the furniture.

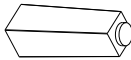









escala (1:1)

LEGENDA	DESCRIÇÃO/DESCRIPCIÓN/DESCRIPTION	CÓDIGO	QUANT.
A	 PARAFUSO/TORNILLO/SCREW 4X45	07653	31
B	 PARAFUSO/TORNILLO/SCREW 3,5X12	01328	50
H	 PREGO/CLAVO/NAIL 10X10	01330	60
D	 CAVILHA/TARUGO/DOWEL 6X30 MM	01211	34
G	 PARAFUSO/TORNILLO/SCREW 4X16	01319	36
J	 BUCHA/BUJE/BUCHING	01311	04
I	 PARAFUSO DE UNIÃO/TORNILLO PARA UNIÓN BOLT FOR UNION	01495	02
M	 PARAFUSO/TORNILLO/SCREW 3,5X25	03130	04
Q	 PARAFUSO/TORNILLO/SCREW 6X50	03827	04
LEGENDA	DESCRIÇÃO/DESCRIPCIÓN/DESCRIPTION	CÓDIGO	QUANT.
J	 PÉ/PATA/FOOT	04116	04
Q	 PARAFUSO/TORNILLO/SCREW 5X45	01320	04

VENDIDO SEPARADAMENTE/SE VENDE POR SEPARADO/SOLD SEPARATELY

escala (N/A)

Ferragens/ Herrajes/ Hardware

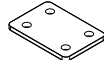
LEGENDA	DESCRIÇÃO/DESCRIPCIÓN/DESCRIPTION	CÓDIGO	QUANT.
V	 FIXADOR COSTA/FIJADOR FONDO/ FIXER COAST	01331	06
F	 COLA/PEGAMENTO/GLUE	01213	01
N	 CANTONEIRA/PIEZA L/METAL SHEET 22X22MM	01270	14
K	 DOBRADIÇA/BISAGRA/HINGE	01271	06
P	 PUXADOR/PEGADOR/HANDLE	06266	01
P1	 PUXADOR/PEGADOR/HANDLE	06263	01
	 ETIQUETA LOGO DECIBAL LABEL DECIBAL	01312	01
Z	 SAPATA/ZAPATA/LOW SHOES 15X15 MM	01367	04
PG	 PISTÃO GÁS / PISTÓN DE GAS / GAS PISTON	03911	01
S	 SUPORTE AÉREO/APOYO AÉREO/AIR SUPPORT	03828	04
C	 CHAPA FIXAÇÃO/ FIJACIÓN DE LA PLACA/ PLATE FIXATION	07751	04

Medida em mm

