

Item	Caixa	Qtd	Descrição/ Descripción	Medidas (mm)	D178-83 Moka	D178-94 Rústico
01	2/4	01	Rodapé Frontal/ Rodapié frontal	2139x73x15	03271158	03271160
02	1/4	02	Travessa do Rodapé/ Travessa pie de página	480x73x15	03301140	03301140
03	2/4	01	Rodapé Traseiro/ Rodapié trasero	2139x73x15	03271159	03271159
04	1/4	01	Lateral Esquerda/ Lateral izquierda	2162x537x15	03152824	03152826
05	2/4	01	Base/ Base	2139x537x15	03292695	03292698
06	1/4	01	Divisão Esquerda/ División izquierda	2074x507x15	03061254	03061257
07=14	3/4	03	Prateleira/ Estante	705x400x15	03221149	03221149
08	1/4	01	Divisão Direita/ División derecha	2074x507x15	03061253	03061256
09	4/4	01	Tampa da cômoda/ Cubierta de tocador	699x506x15	03292696	03292699
10	2/4	01	Divisão da Colméia/ División Colméia	948x398x15	03061255	03061255
11	3/4	04	Prateleira da Colméia/ Estante de la colmena	396x342x15	03221150	03221150
12	1/4	01	Lateral Direita/ Lateral derecha	2162x537x15	03152823	03152825
13	2/4	01	Prateleira do Calceiro/ Estantería Calceiro	705x250x15	03221151	03221151
14=07	3/4	01	Prateleira/ Estante	705x400x15	03221149	03221149
15	3/4	01	Prateleira Menor/ Estante Menor	699x400x15	03221152	03221152
16	2/4	01	Tampo/ Tapa	2169x537x15	03292697	03292700
17	2/4	01	Batente/ Aldaba	699x44x15	03250594	03250595
18	2/4	02	Moldura Lateral/ Cornija lateral	537x73x15	03161256	03161261
19	2/4	01	Moldura Frontal/ Cornija frontal	2201x73x15	03161255	03161260
20	1/4	01	Fundo Superior/ Fondo Superior	2163x422x3	03111364	03111364
21	4/4	01	Fundo Central/ Fondo Central	1681x711x3	03111363	03111363
22	4/4	02	Fundo/Fondo	1681x725x3	03111362	03111362
23	4/4	02	Porta/Puerta	2046x712x12	03211826	03211829
24	4/4	01	Porta Central/ Puerta Central	1321x250x15	03211828	03211831
25	4/4	01	Porta Espelho/ Puerta Espejo	1321x440x15	03211827	03211830
26	3/4	03	Frente de Gaveta/ Frente del cajón	692x152x15	03131055	03131057
27=31	2/4	06	Lado de Gaveta/ Lado del cajón	350x122x15	03140535	03140535
28=32	2/4	03	Fundo de Gaveta/ Fondo del cajón	655x361x3	03120476	03120476
29=33	3/4	03	Ripa de Trás/ Listón trasero	674x122x15	03240643	03240643
30	4/4	01	Frente de Gaveta Maior/ Frente del cajón Mayor	692x215x15	03131056	03131058
31=27	3/4	02	Lado de Gaveta/ Lado del cajón	350x122x15	03140535	03140535
32=28	2/4	01	Fundo de Gaveta/ Fondo del cajón	655x361x3	03120476	03120476
33=29	3/4	01	Ripa de Trás/ Listón trasero	674x122x15	03240643	03240643

AVISO

Para limpeza de seu móvel, use uma flanela seca ou umedecida, e não utilize produtos químicos que possam danificar seu produto.

SISTEMA DE MONTAGEM

O sistema de montagem dos produtos, funciona de acordo com a ordem crescente dos números indicados no desenho. Ex: 01, 02, 03, 04... até a conclusão da montagem.

ADVERTENCIA

Para limpieza de su móvil, use una flanela seca o húmeda, y no utilice productos químicos que puedan dañar su producto.

SISTEMA DE MONTAJE

El sistema de montaje de los productos funciona de acuerdo con el orden creciente de los números indicados en el dibujo. Ej.: 01, 02, 03, 04... hasta la conclusión del montaje.

HENN**MÓVEIS
DO SEU
JEITO**

www.henn.com.br
henn@henn.com.br
55 49 3674 3500
Mondai/SC - Brasil

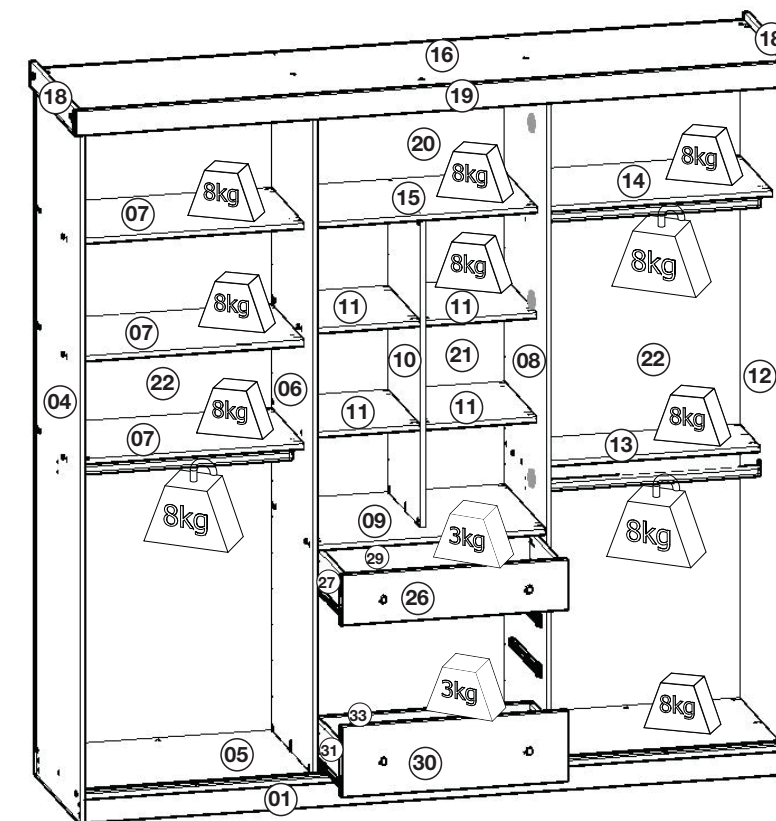
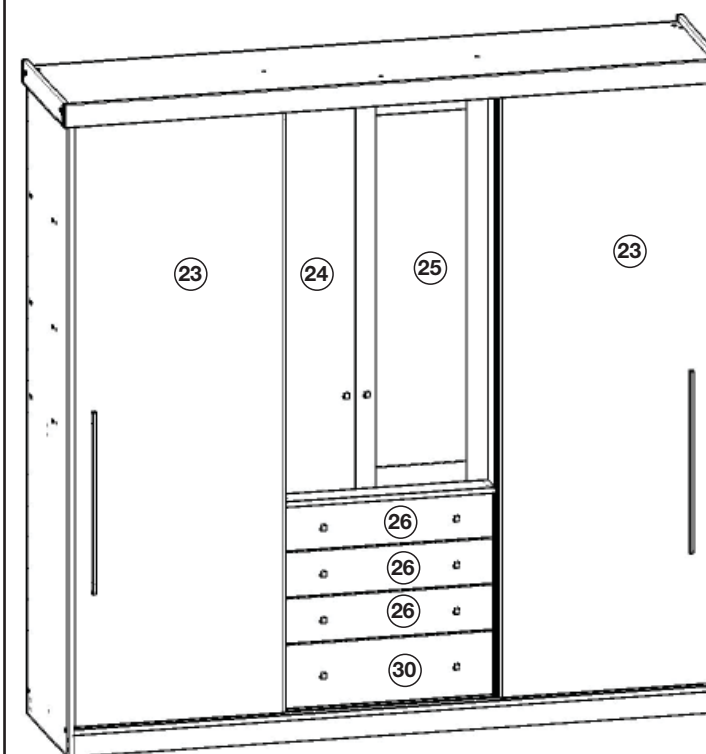
**INSTRUÇÃO DE MONTAGEM
INSTRUCCIONES ASAMBLEA****Roupeiro Boreal 04 portas 4 gavetas/ Armario Boreal 04 puertas 04 cajones**





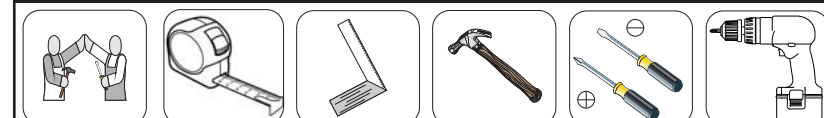















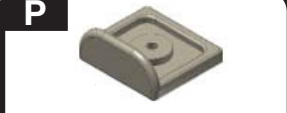

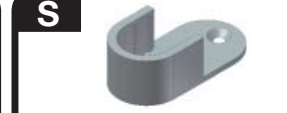

Pesos máximos recomendados com carga uniformemente distribuídas.
Peso máximo recomendado con la carga distribuida uniformemente.

- D178-83 - Moka
 D178-94 - Rústico

**REQUISITOS PARA MONTAGEM
REQUISITOS PARA LA ASAMBLEA**

Imagens meramente ilustrativas / Imágenes meramente ilustrativas

LISTA DE FERRAGENS

A  08x Paraf. 4,5x50mm CHT.	B  04x Paraf. 3,5x18mm FLA	C  45x Paraf. 3,5x40mm CHT.	D  10x Paraf. 3,5x25mm FLA.	E  42x Paraf. 3,5x14mm FLA.
F  78x Paraf. 3,5x12mm CHT.	G  08x Paraf. 3,0x16mm CHT.	H  108x Cavilha 8x25mm	I  04x Parafuso minifix	J  04x Tambor minifix
K  46x Fixador de fundos	L  16x Prego 12x12 anelado	M  162x Prego 10x10	N  08x Cantoneira suporte triangular	O  08x Porca cilíndrica
P  08x Sapata "L" 15x15	Q  12x Cantoneira plástica	R  05x Conector de montagem	S  06x Suporte cabideiro	T  10x Puxador Kannan Pontual
U  02x Puxador alum. 611mm	V  02x Giz de correção	W  02x Sachê de cola	X  01x Etiqueta resinada Henn	Y  03x Cabideiro alum. 699mm
Z  01x Kit Rodízio CM110 2Pts	AA  04x Corrediça metal 350mm	AB  06x Calço metal 12mm	AC  06x Dobradiça metal 26mm	AD  01x Trilho de alumínio 2137mm
AE  01x Trilho sup plástico 2137mm	AF  37x Adesivo tapa parafuso 10mm	AG  20x Adesivo tapa parafuso perfil	AH  12x Batente injetad PVC	AI  04x Perfil anti-tempo U 2044mm

A ferragem "AI" só será usado em caso de pedido de assistência técnica. Pois o perfil anti-tempo "U" já vem montado nas portas de fábrica.

Hardware "AI" sólo se utiliza en caso solicitar asistencia técnica, para el perfil anti-tempo "U" viene montados en las puertas de fábrica.

Colocação das sapatas (P) nas peças (01 e 03)

Colocação das cantoneiras (Q) com os parafusos 3,5x14 (E) nos rodapés.

La colocación de las esquinas (Q) con tornillos 3,5x14 (E) en los pies.

Aconselha-se fixar o Trilho (AD) na Base (05) antes de acoplar ao produto.

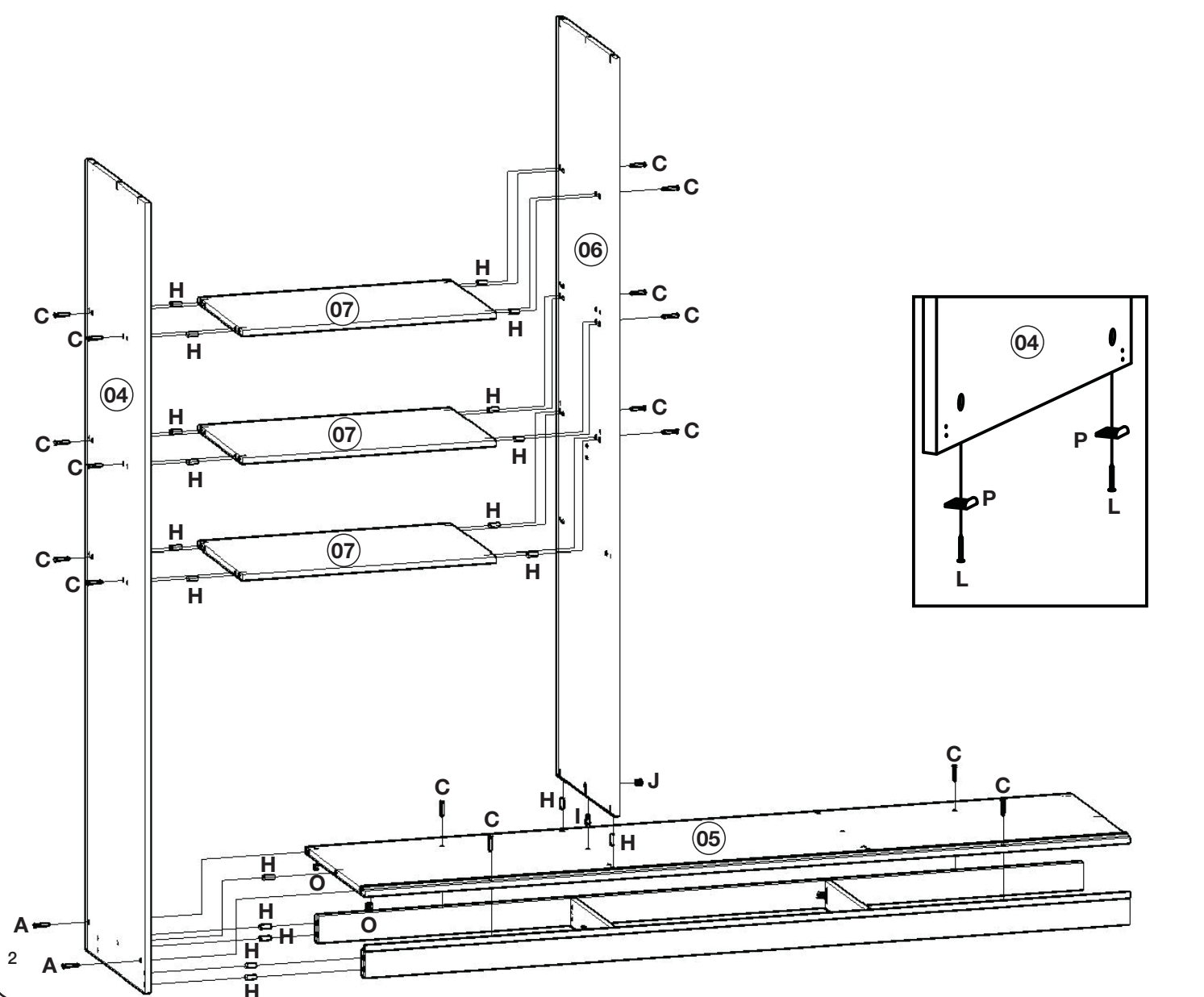
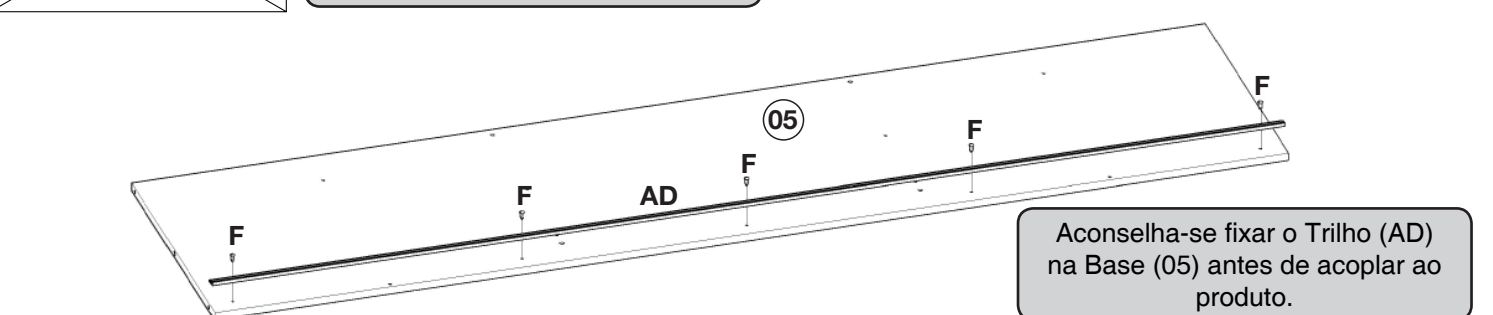
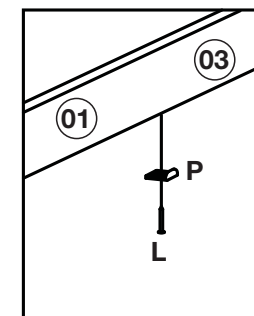
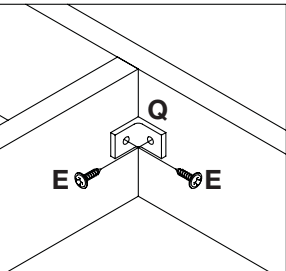
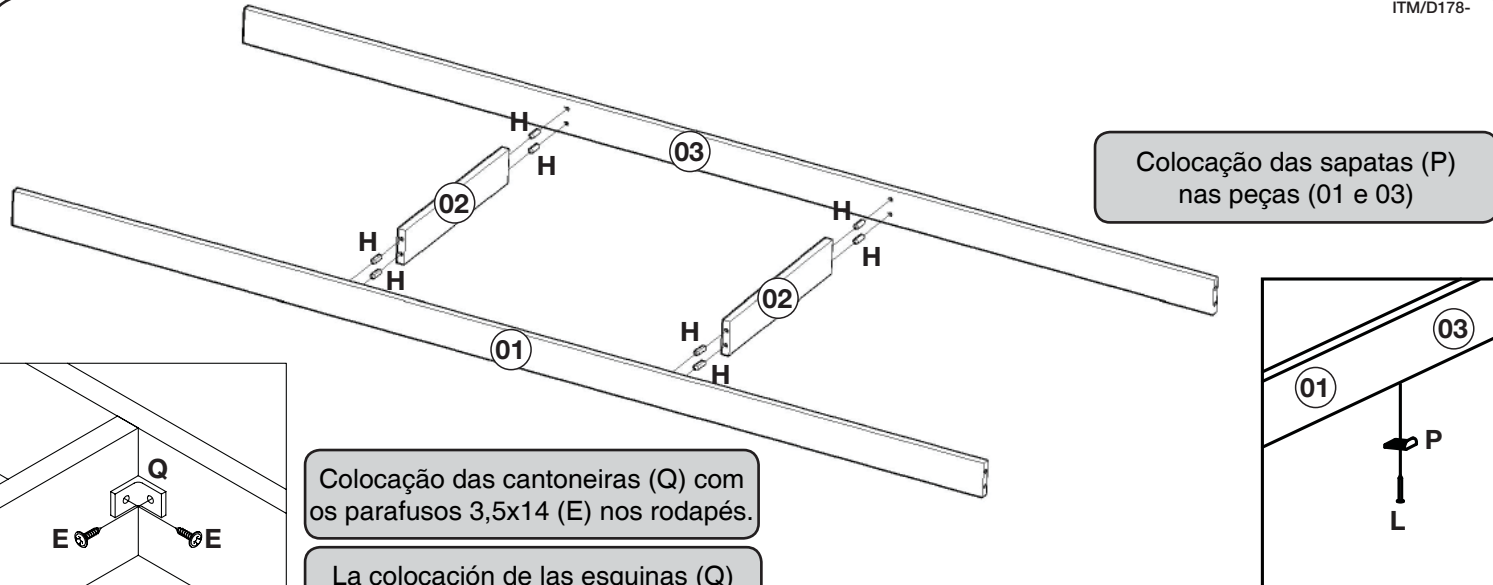

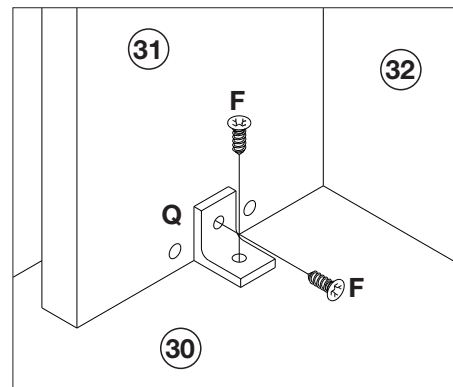
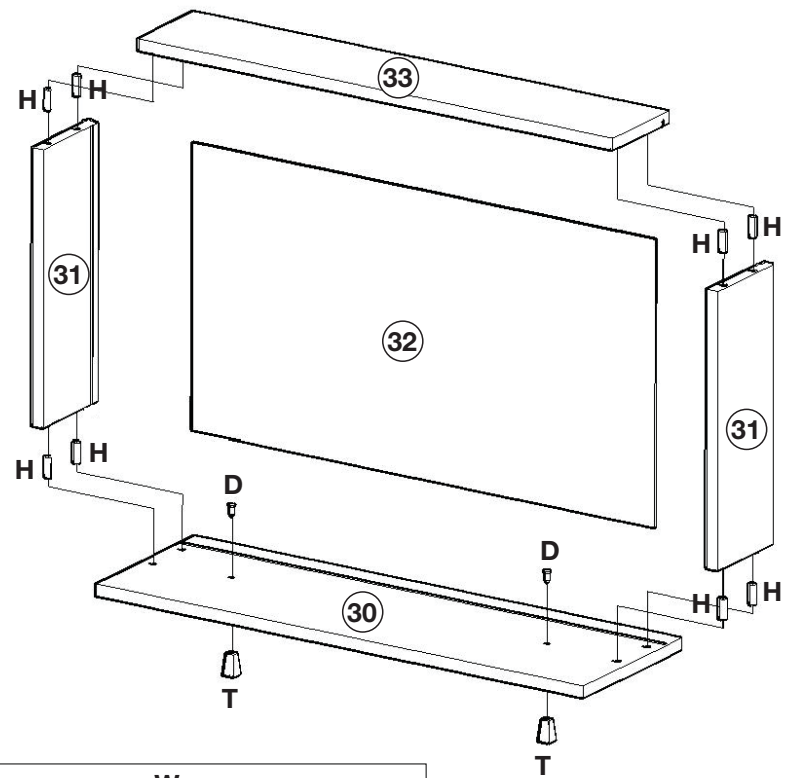

A peça nº 31 igual ao nº 27.
 El número de pieza 31 iguales que nº 27.

A peça nº 32 igual ao nº 28.
 El número de pieza 32 iguales que nº 28.

A peça nº 33 igual ao nº 29.
 El número de pieza 33 iguales que nº 29.

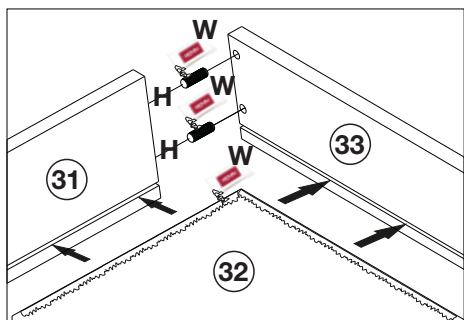

Utilize o sachê de cola (W) nas cavilhas (H) e nos frisos da gaveta.

El uso de pegamento de paquetes (W) sobre los pasadores (H) y las cuentas de los cajones.

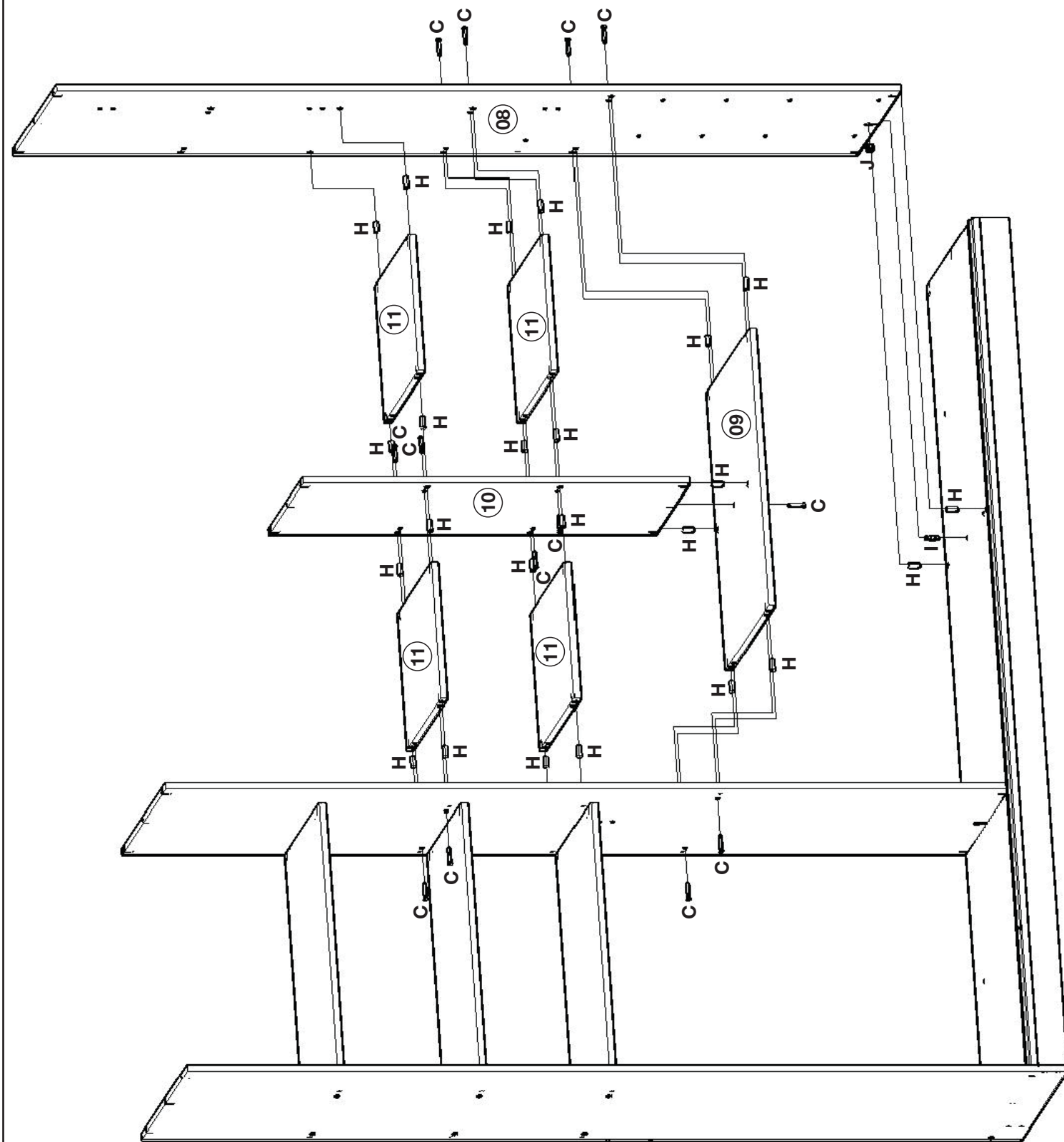
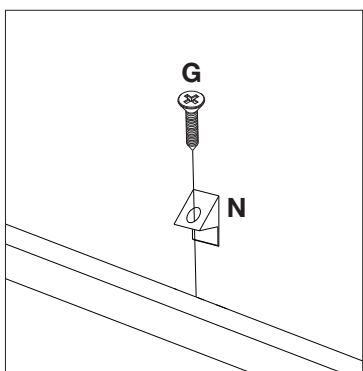
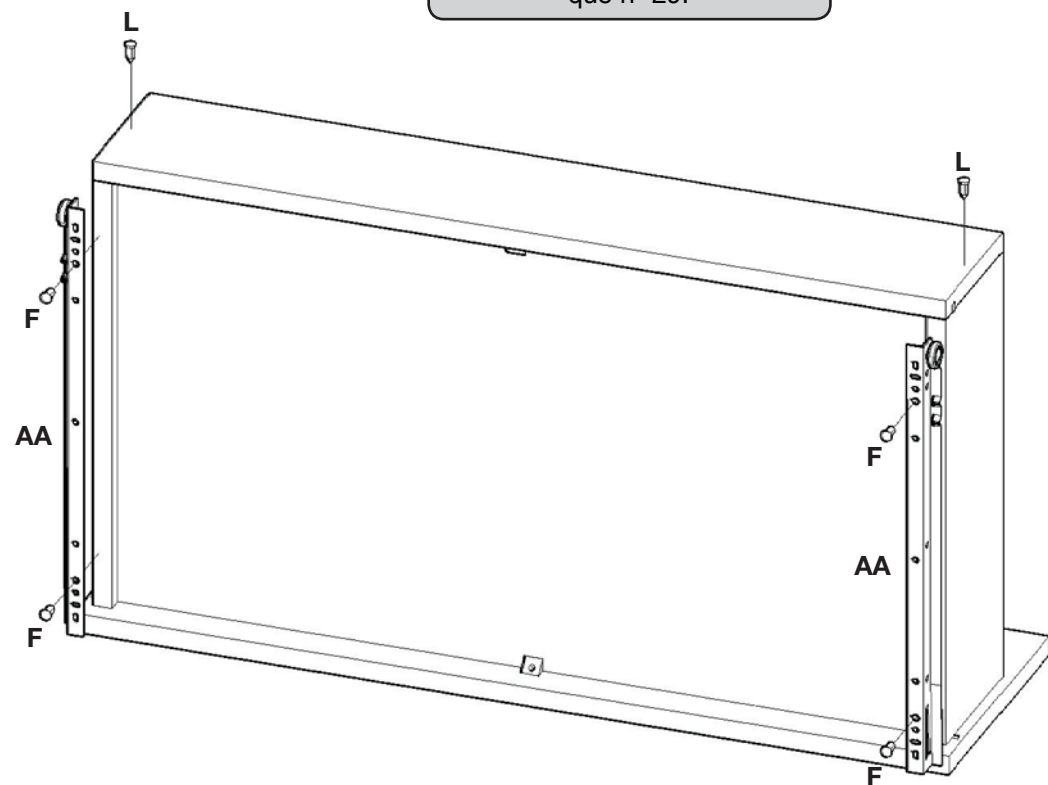

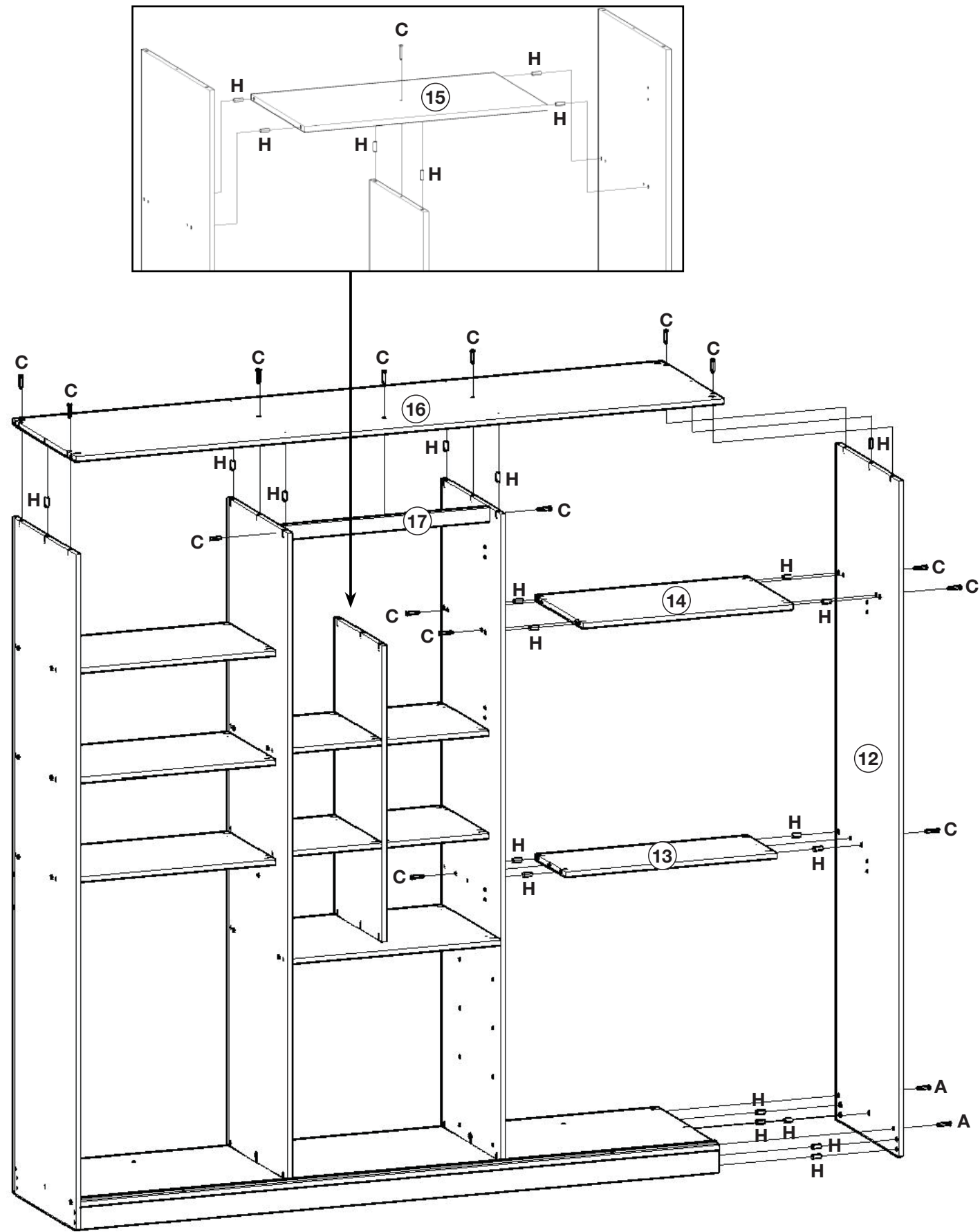

A peça nº 14 igual ao nº 07.

El número de pieza 14 iguales que nº 07.

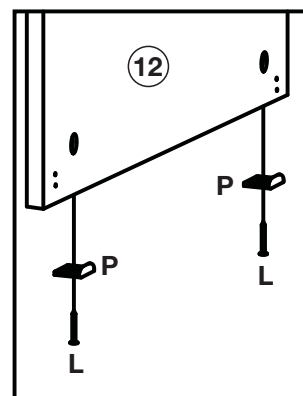

Montagem gaveta 3x

Montaje cajón 3x.

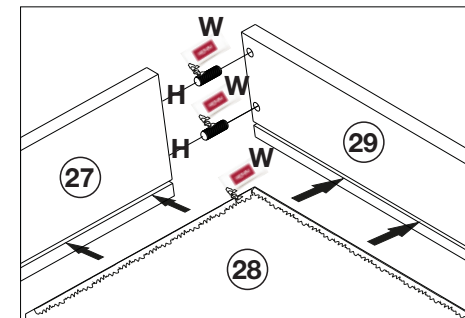
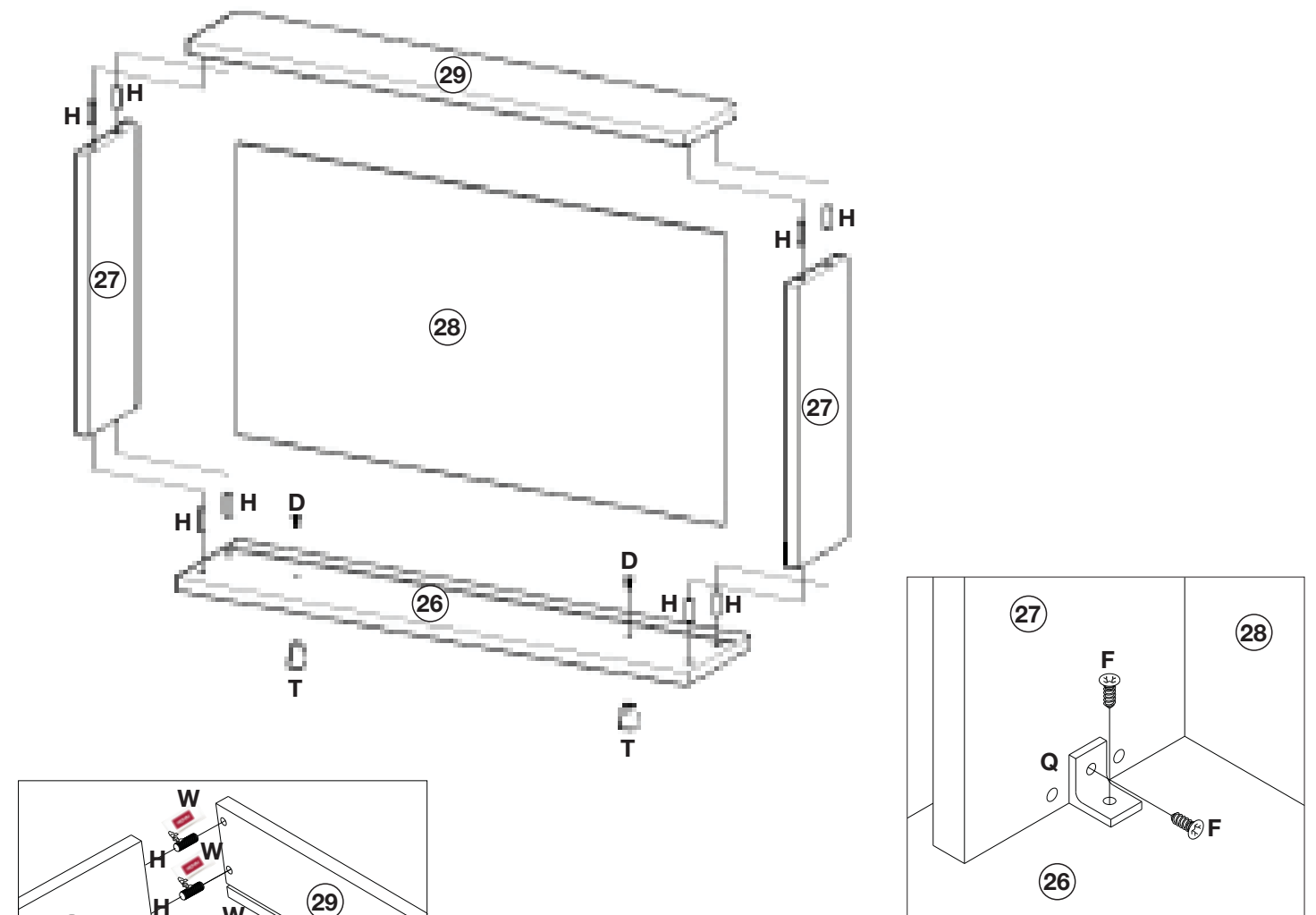

Utilize o sachê de cola (W) nas cavilhas (H) e nos frisos da gaveta.

El uso de pegamento de paquetes (W) sobre los pasadores (H) y las cuentas de los cajones.

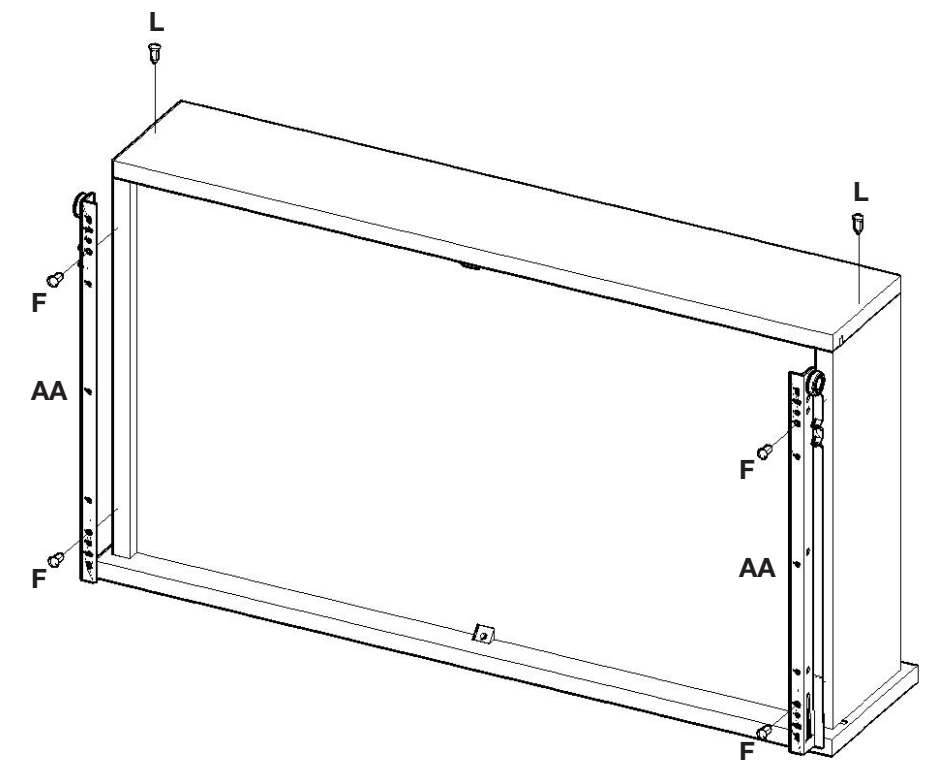
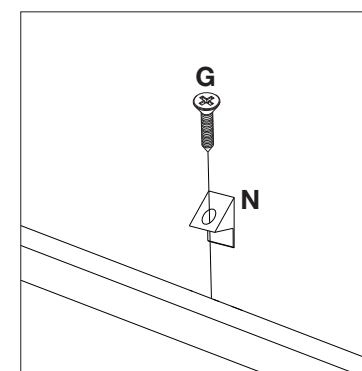

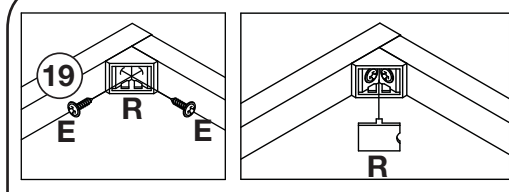
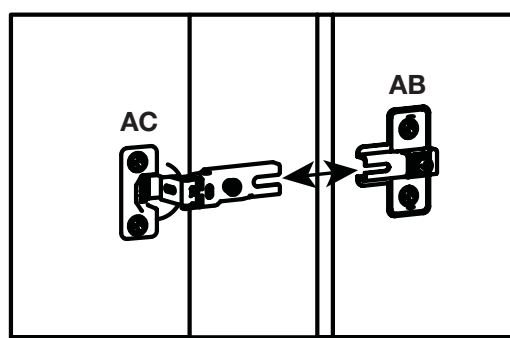
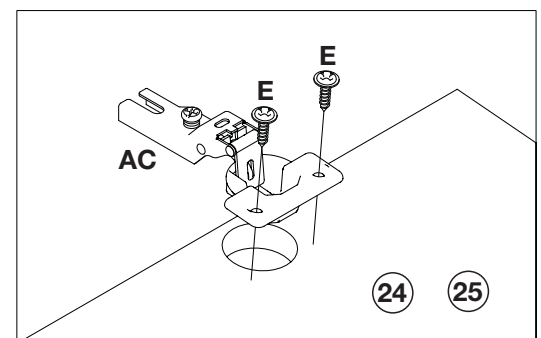
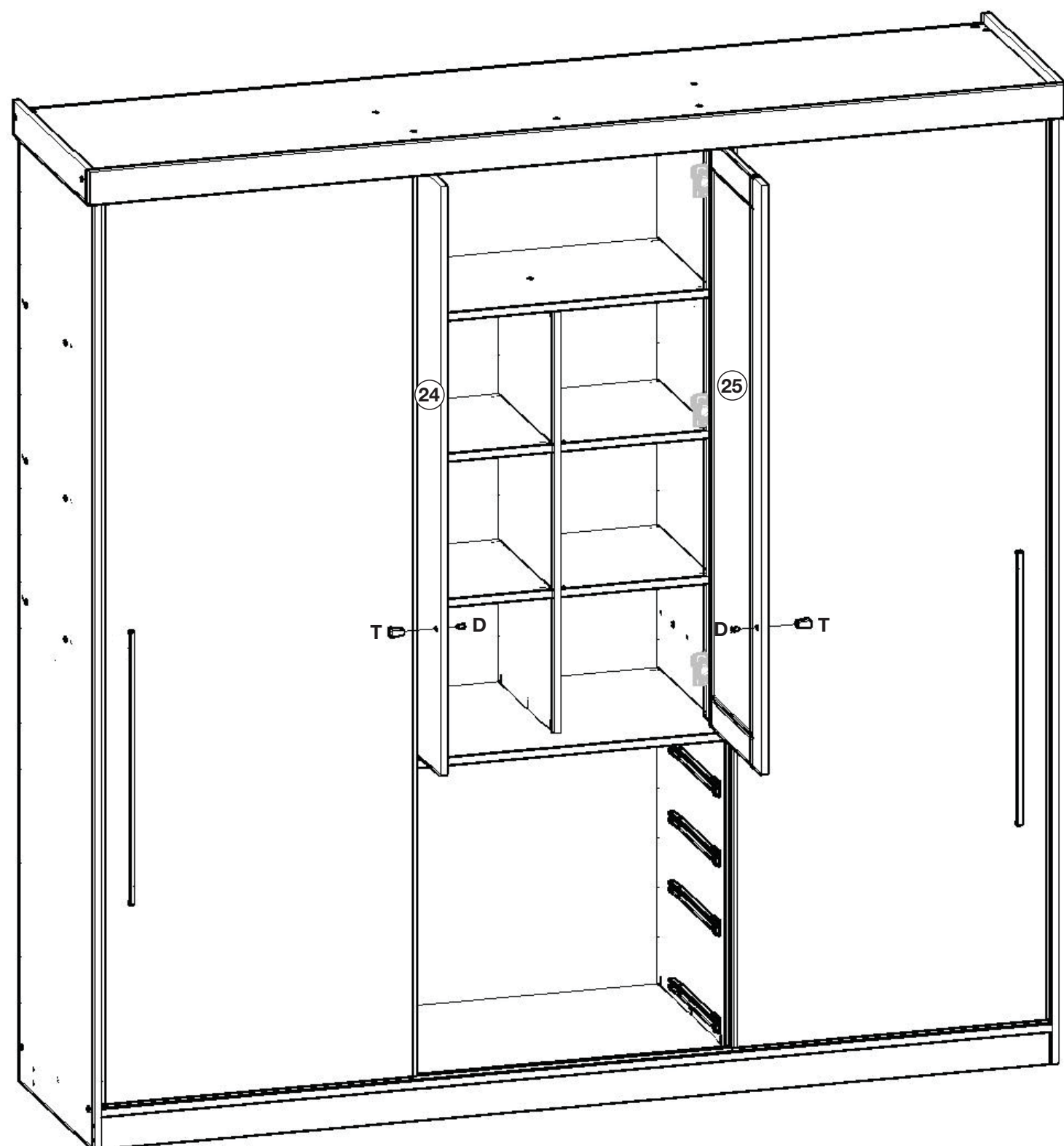

Colocação dos conectores (R) na moldura frontal (19).

La colocación de los conectores (R) el marco frontal (19).

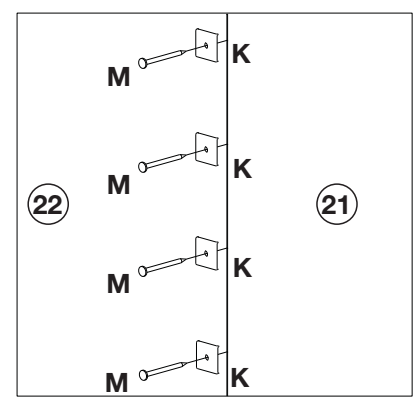
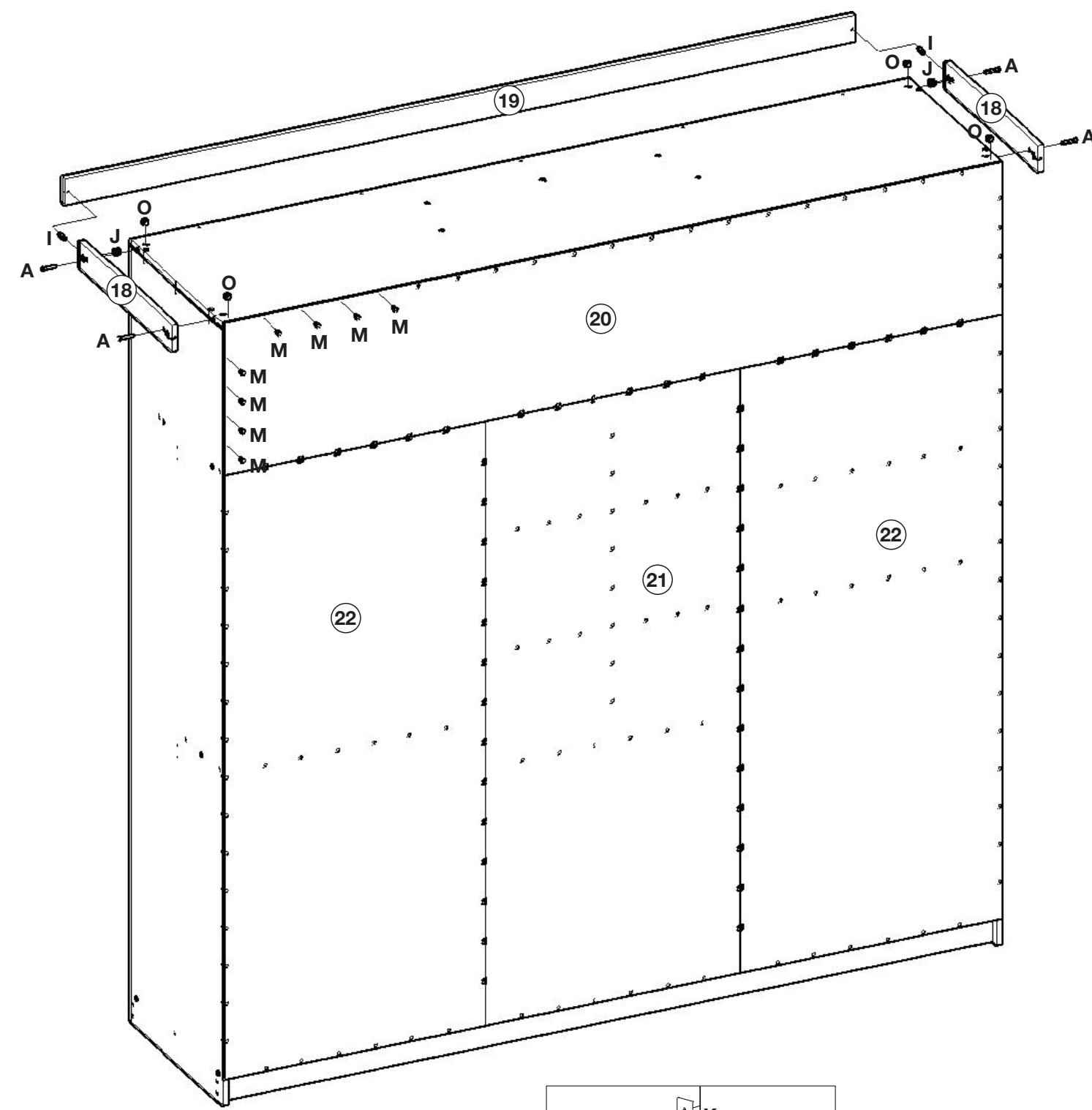
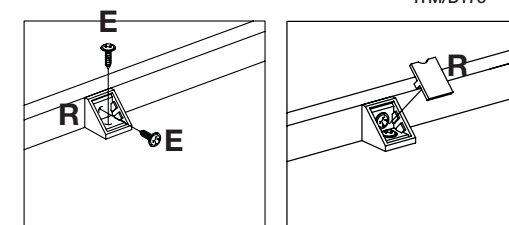

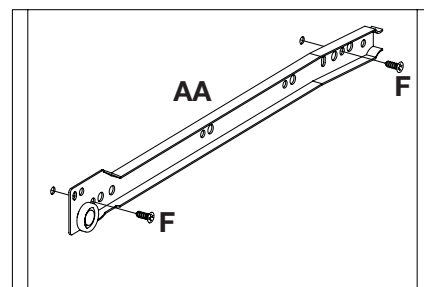
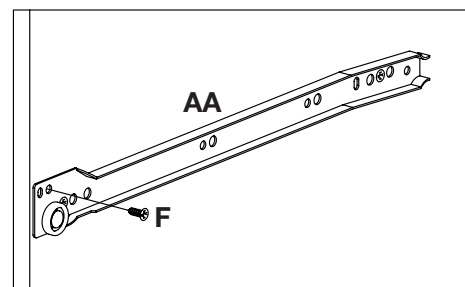
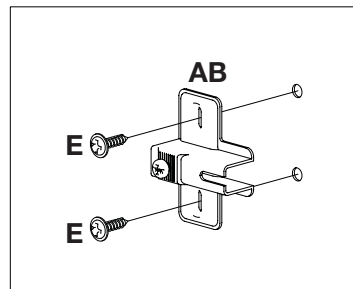
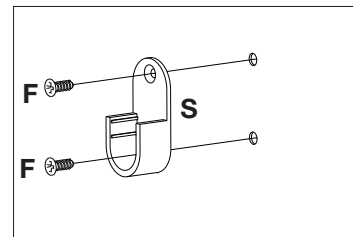
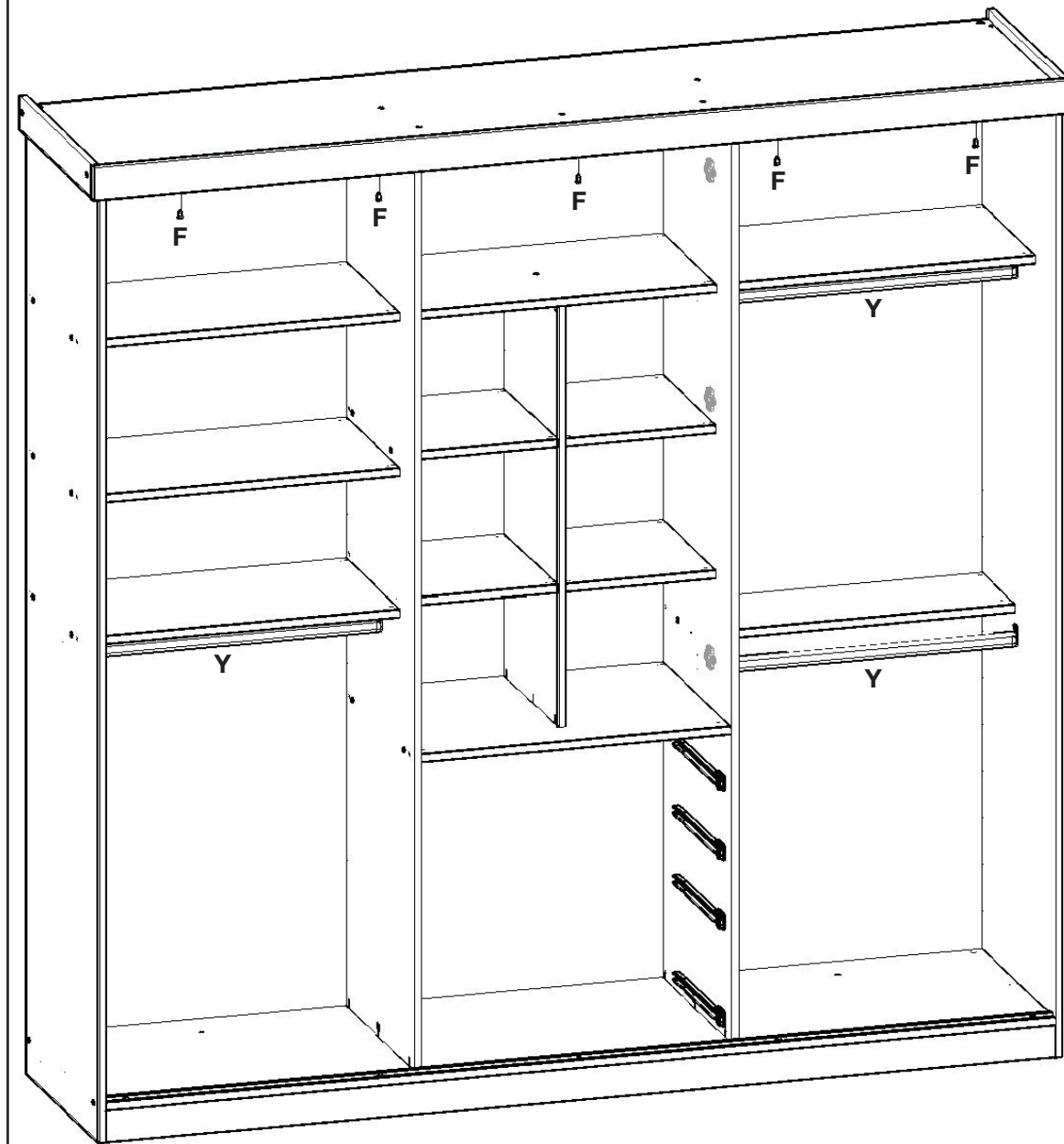
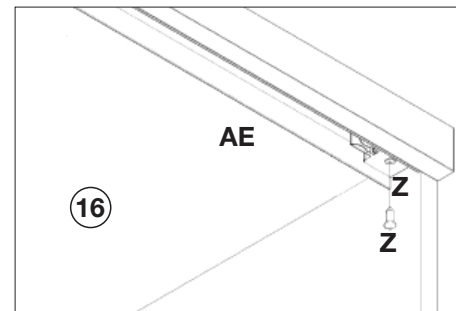
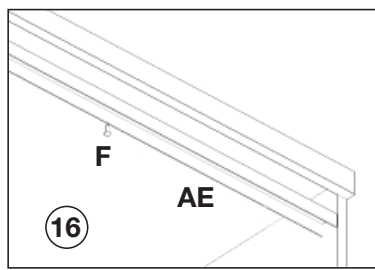

Montagem Porta 2x

Montaje de la Puerta 2x.

Colocar os parafusos das guias (Z) na pinção da porta (23)

