

INSTRUÇÃO DE MONTAGEM INSTRUCCIONES DE MONTAJE

HENN

Cômoda Magno 1Pt 4Gav Cómoda Magno 1Pt 4Gav

Referência/Cor

- D708-10 - Branco
- D708-12 - Malbec
- D708-42 - Fendi
- D708-70 - Amêndoa
- D708-76 - Gris
- D708-83 - Moka
- D708-94 - Rústico

Requisitos para montagem Requisitos para la montaje

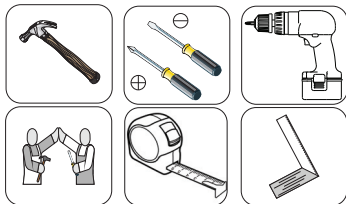

Imagens meramente ilustrativas
Imágenes meramente ilustrativas

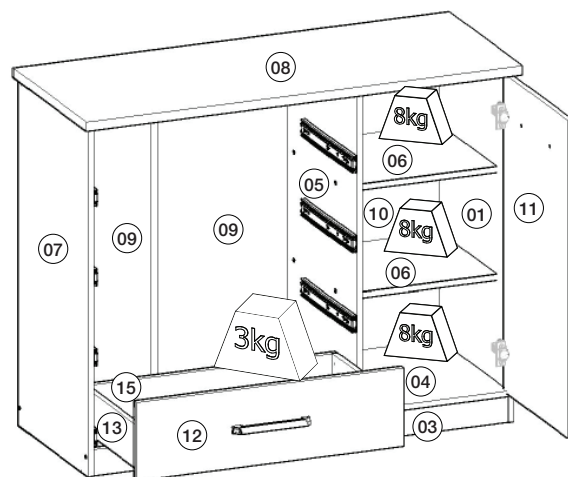
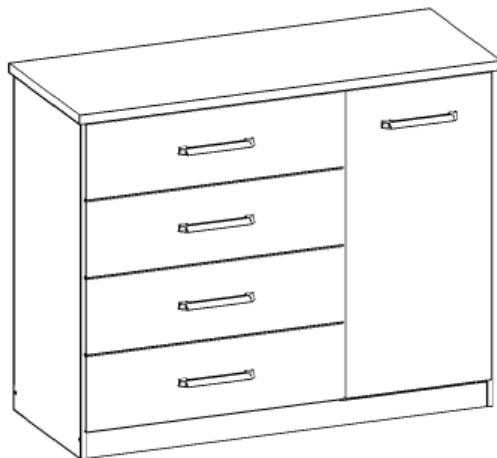

Pesos máximos recomendados com carga uniformemente distribuídas.
Peso máximo recomendado con la carga distribuida uniformemente.

SISTEMA DE MONTAGEM

O sistema de montagem dos produtos, funciona de acordo com a ordem crescente dos números indicados no desenho. Ex: 01, 02, 03, 04... até a conclusão da montagem.

SISTEMA DE MONTAJE

El sistema de montaje de productos funciona de acuerdo con el orden de los números indicados en el dibujo. Ejemplo: 01, 02, 03, 04 ... hasta la realización de la asamblea.

AVISO

Para limpeza de seu móvel, use uma flanela seca ou umedecida, e não utilize produtos químicos que possam danificar seu produto.

ADVERTENCIA

Para la limpieza de sus muebles, utilice un trapo seco o humedecido, y no utilice productos químicos que puedan dañar el producto.

Lista de Peças / Lista de piezas

Item	Caixa	Qtd	Descrição	Medidas (mm)	D708-10 Branco	D708-12 Malbec	D708-42 Fendi	D708-70 Amêndoa	D708-76 Gris	D708-83 Moka	D708-94 Rústico
01	1/2	01	Lateral direita/ Lateral derecha	980x480x15	03152809	03152809	03152809	03152809	03152809	03152809	03152809
02	2/2	01	Rodapé traseiro/ Rodapié trasero	1203x73x15	03271148	03271148	03271148	03271148	03271148	03271148	03271148
03	2/2	01	Rodapé frontal/ Rodapié frontal	1203x73x15	03271147	03271147	03271147	03271147	03271147	03271147	03271147
04	2/2	01	Base/ Base	441x480x15	03292679	03292679	03292679	03292679	03292679	03292679	03292679
05	1/2	01	Divisão/ División	892x480x15	03061237	03061237	03061237	03061237	03061237	03061237	03061237
06	2/2	02	Prateleira/ Estante	426x400x15	03221130	03221130	03221130	03221130	03221130	03221130	03221130
07	1/2	01	Lateral esquerda/ Lateral Izquierda	980x480x15	03152810	03152810	03152810	03152810	03152810	03152810	03152810
08	2/2	01	Tampo/ Tapa	1263x505x25	03292678	03292678	03292678	03292678	03292678	03292678	03292678
09	2/2	02	Fundo Cru/ Fondo sin procesar	922x388x3	03111346	03111346	03111346	03111346	03111346	03111346	03111346
10	2/2	01	Fundo/ Fondo	922x445x3	03111345	03111345	03111345	03111345	03111345	03111345	03111345
11	2/2	01	Porta/ Puerta	892x436x15	03211812	03211812	03211812	03211812	03211812	03211812	03211812
12	2/2	04	Frente de gaveta/ Frente del cajón	772x220x15	03131050	03131050	03131050	03131050	03131050	03131050	03131050
13	1/2 e 2/2	08	Lado de gaveta/ Lado del cajón	400x122x15	03140531	03140531	03140531	03140531	03140531	03140531	03140531
14	1/2	04	Fundo de gaveta/ Fondo del cajón	718x411x3	03120473	03120473	03120473	03120473	03120473	03120473	03120473
15	1/2 e 2/2	04	Ripa de trás/ Listón trasero	737x122x15	03240639	03240639	03240639	03240639	03240639	03240639	03240639

Lista de Ferragens

A 04. Paraf. 4,5x50mm CHT.	B 10. Paraf. 3,5x40mm CHT.	C 10. Paraf. 3,5x25mm FLA.	D 18. Paraf. 3,5x14mm FLA.	E 64. Paraf. 3,5x12mm CHT.	F 08. Paraf. 3,0x16mm CHT.	G 54. Caviha 8x25mm	H 48. Pregro 10x10
I 14. Pregro 12x12 anelado	J 08. Fixador de fundo	K 13. Cantoneira plástica	L 08. Cantoneira suporte triangular	M 04. Porca cilíndrica 12x12	N 02. Calço metal 5mm	O 02. Dobradiça metal 26mm	P 04. Corrediça telescópica
Q 05. Puxador Econ 192mm Cromado	R 06. Sapata "L" 15x15	S 01. Perfil "H" 905mm	T 01. Etiqueta resinada Henn	U 02. Sachê de cola	V 09. Adesivo tapa parafuso 10mm		

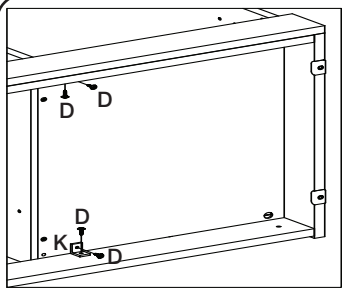

Fixação da cantoneira (K) nos rodapés (02 e 03) e na Base (04).

Soporte de fijación (K) en las notas al pie (02 y 03) y la base (04).

Fixação da cantoneira (K) no Tampo (09)

Soporte de fijación (K) de la superficie (09)

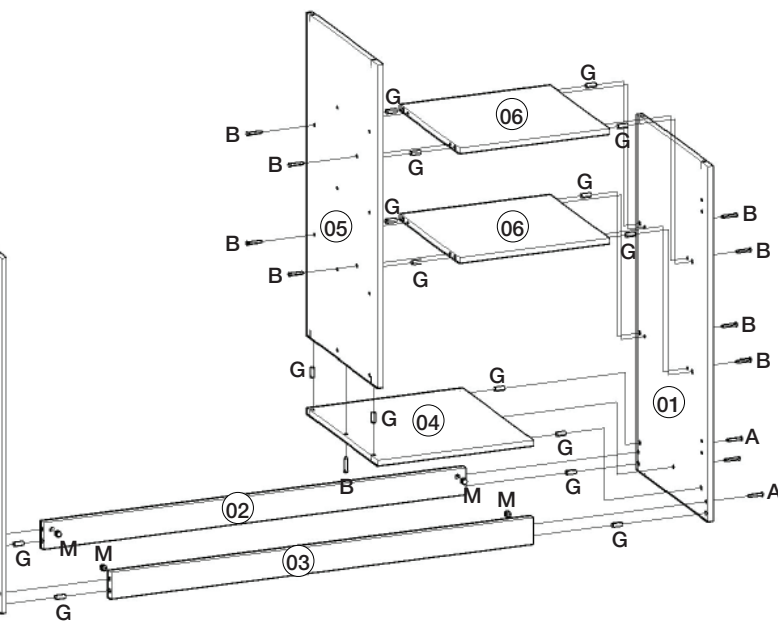
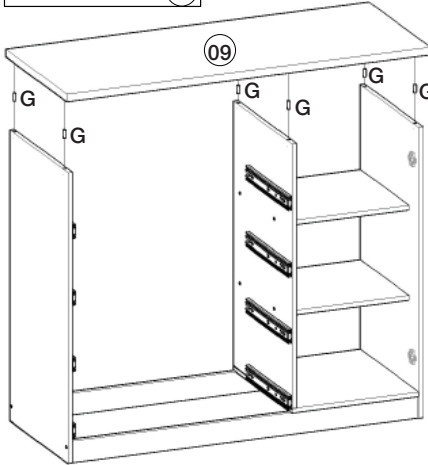
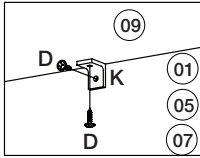

Fixação da Sapata "L" 15x15 nas laterais (01 e 07) e nos rodapés (02 e 03).

Fijación de la zapata 15x15 "L" en los laterales (01 y 07) y pies de página (02 y 03).

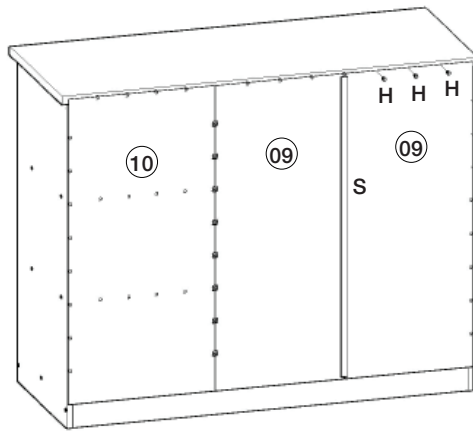
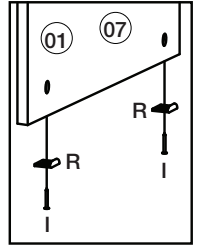

Fixar os pregos (H) a 100mm de distância um para outro.

Fijar los pernos (H) prisioneros 100 mm de distancia de uno a otro.

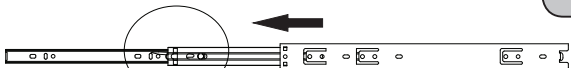
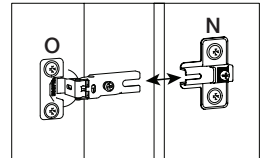
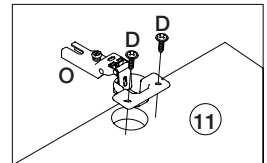
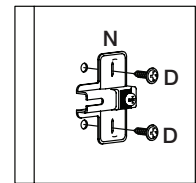
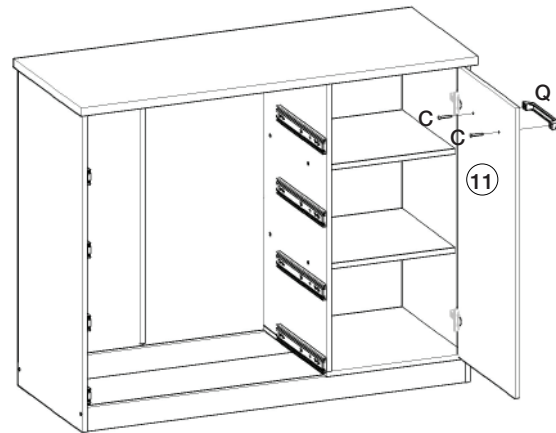

Para a desmontagem da corredeira siga a instrução ao lado.

Para el desmontaje seguimiento de diapositivas la instrucción siguiente a.

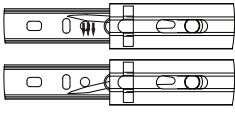

Fixar as corredeiras nessas furações

Fijar las diapositivas de estos agujeros

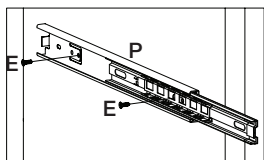
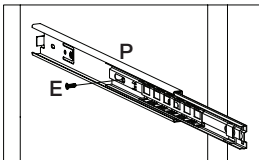

Montagem gaveta 04x

