

Peso distribuido
de maneira
uniforme

Peso distribuido
de maneira
uniforme

Distributed
weight so
uniform

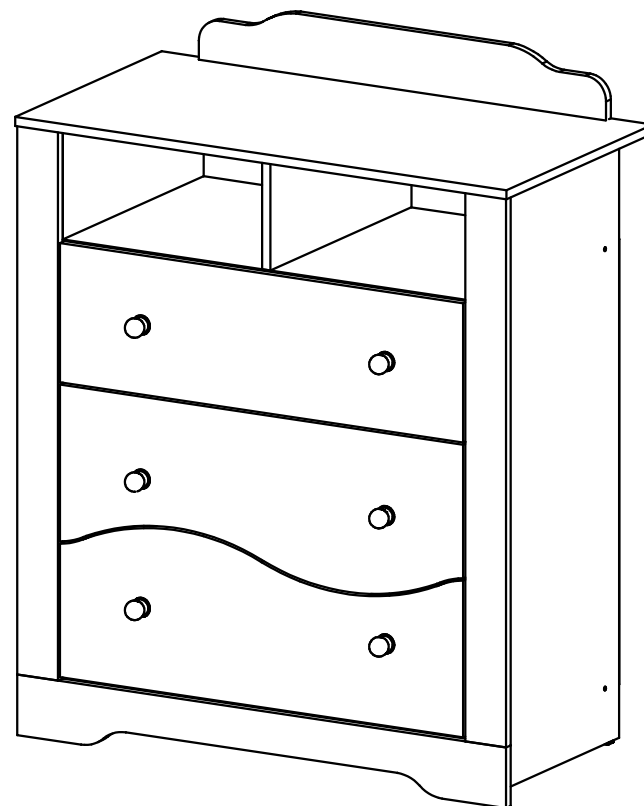
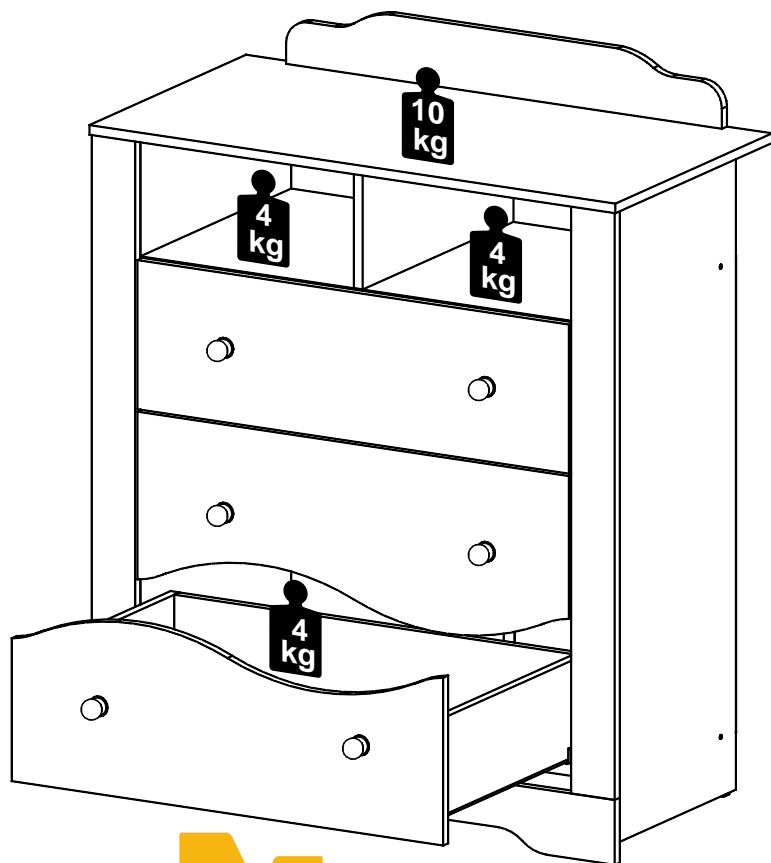

INSTRUÇÕES DE MONTAGEM
INSTRUCCIONES DE ARMADO
ASSEMBLY INSTRUCTIONS

REF.: 2352



MULTIMÓVEIS
baby

Rua Carlos Dreher Neto, 1918, Fone: (54) 2102 4000, FAX: (54) 2102 4050
CEP 95700-000 - BENTO GONÇALVES - RS - BRASIL
CNPJ: 00.349.443/0001-92
e-mail: multimoveis@multimoveis.com / site: www.multimoveis.com

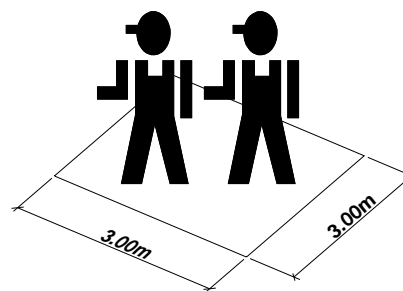



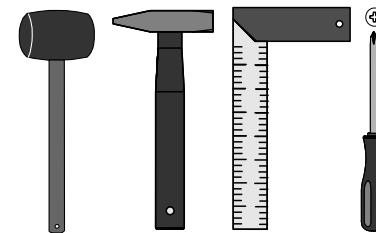





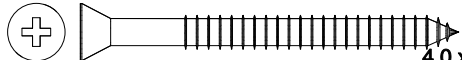

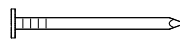
FERRAMENTAS NECESSÁRIAS
HERRAMIENTAS NECESARIAS
TOOLS NECESSARY

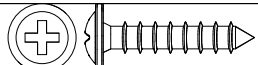

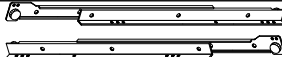
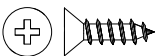
60 min



| | | |
|----|---|----|
| B |  4,0 x 45 | 12 |
| J |  6,0 x 40 | 04 |
| Y |  10 x 10 | 40 |
| AG |  6,0 x 30 | 24 |
| AT |  | 18 |
| BA |  4,0 x 25 | 06 |
| BO |  4,0 x 35 | 12 |
| BX |  COLA | 01 |
| CA |  350 MM | 03 |
| CC |  3,5 X 10 | 76 |
| ED |  Tampa Adesiva Papel | 08 |
| EF |  | 04 |
| PX |  | 06 |
| SU |  | 02 |

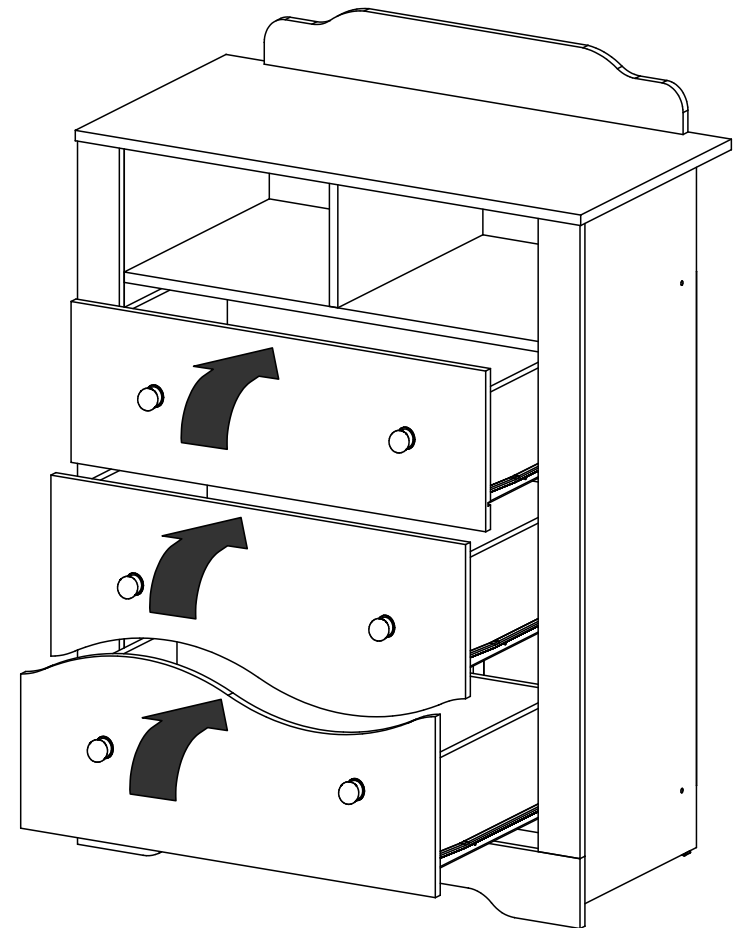

Utilizar a régua abaixo para medir as ferragens:



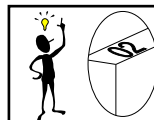
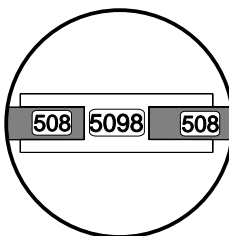

Senhor montador!
Informamos que a numeração das peças encontra-se no topo das mesmas conforme desenho acima.

Señor Armador!
Le informamos que la numeración de las piezas encuentranse arriba de las mismas, de acuerdo al modelo arriba.

Dear Assembler!
We inform you that the number of each piece is located on the top of it, according to the model shown above.

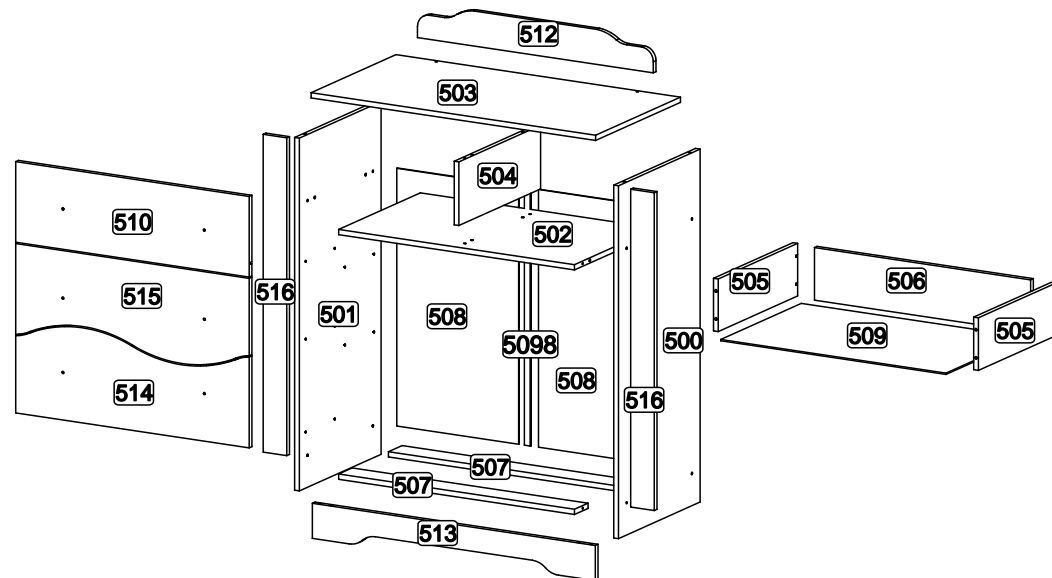
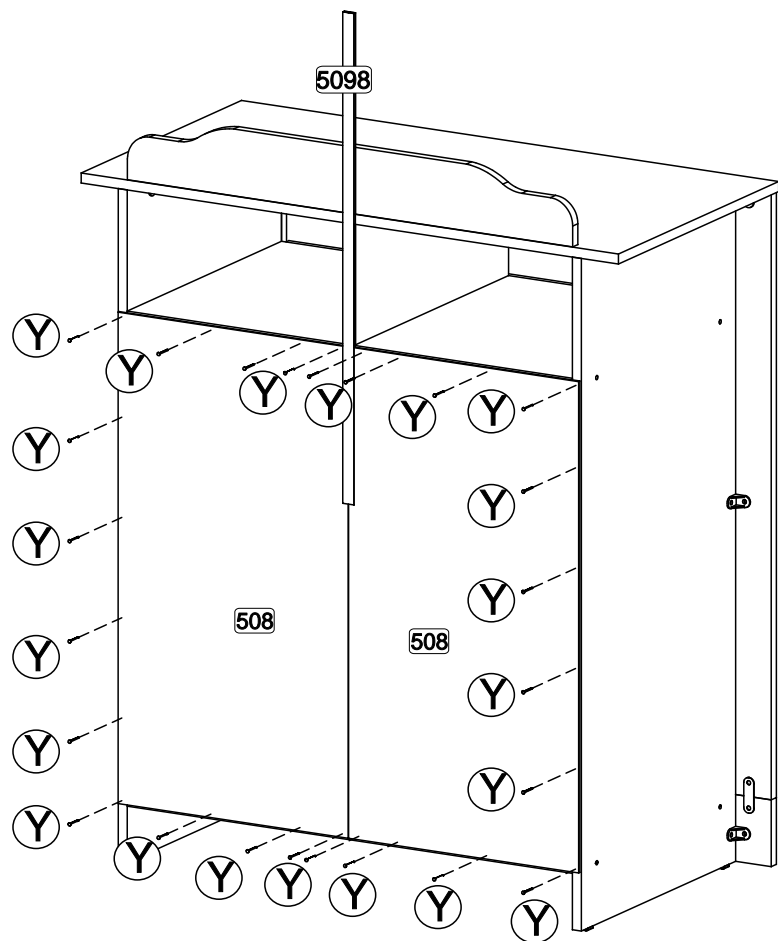

LISTA DE PEÇAS

| N° | DENOMINAÇÃO |
|------|---------------------------------|
| 500 | LATERAL DIREITA |
| 501 | LATERAL ESQUERDA |
| 502 | PRATELEIRA |
| 503 | TAMPO |
| 504 | DIVISÃO |
| 505 | LATERAL DE GAVETA |
| 506 | COSTA DE GAVETA |
| 507 | TRAVESSA |
| 508 | COSTA |
| 509 | FUNDO DE GAVETA |
| 510 | FRENTE DE GAVETA |
| 512 | MOLDURA SUPERIOR |
| 513 | RODAPÉ FRONTAL |
| 514 | FRENTE DE GAVETA INFERIOR CURVA |
| 515 | FRENTE DE GAVETA SUPERIOR CURVA |
| 516 | MOLDURA LATERAL |
| 5098 | PERFIL I |



LISTA DE PIEZAS

| N° | DENOMINACIÓN |
|------|-----------------------------|
| 500 | LATERAL DERECHA |
| 501 | LATERAL IZQUIERDA |
| 502 | ESTANTE |
| 503 | TAPA |
| 504 | DIVISIÓN |
| 505 | LATERAL CAJÓN |
| 506 | RESPALDO CAJÓN |
| 507 | TRAVIESA |
| 508 | RESPALDO |
| 509 | FONDO CAJÓN |
| 510 | FRENTE CAJÓN |
| 512 | MOLDURA SUPERIOR |
| 513 | ZÓCALO FRONTAL |
| 514 | FRENTE CAJÓN INFERIOR CURVA |
| 515 | FRENTE CAJÓN SUPERIOR CURVA |
| 516 | MOLDURA LATERAL |
| 5098 | PERFIL I |



PART LIST

| N° | DESCRIPTION |
|------|-------------------------|
| 500 | RIGHT SIDE |
| 501 | LEFT SIDE |
| 502 | SHELF |
| 503 | TOP |
| 504 | DIVISION |
| 505 | DRAWER SIDE |
| 506 | DRAWER BACK |
| 507 | CROSS BAR |
| 508 | BACK |
| 509 | BOTTOM DRAWER |
| 510 | FRONT DRAWER |
| 512 | UPPER FRAME |
| 513 | FRONT SKIRTING BOARD |
| 514 | LOWER FRONT DRAWER BEND |
| 515 | TOP FRONT DRAWER BEND |
| 516 | SIDE FRAME |
| 5098 | I PROFILE |

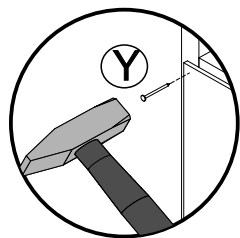

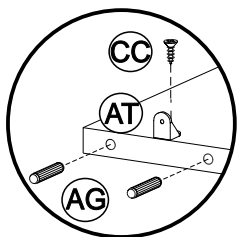
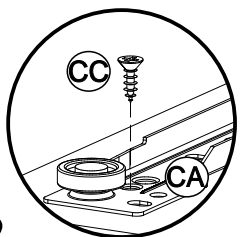
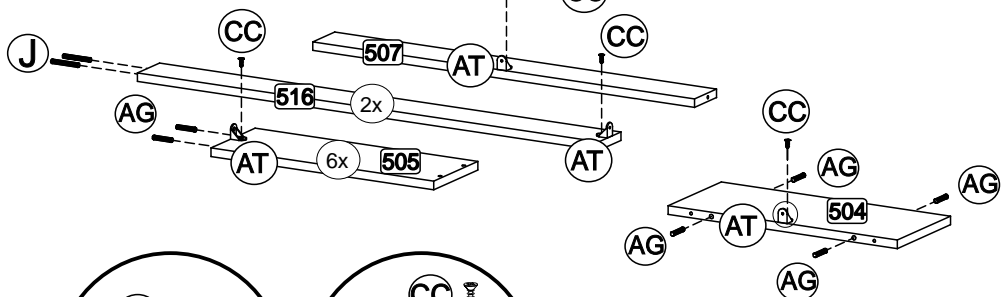
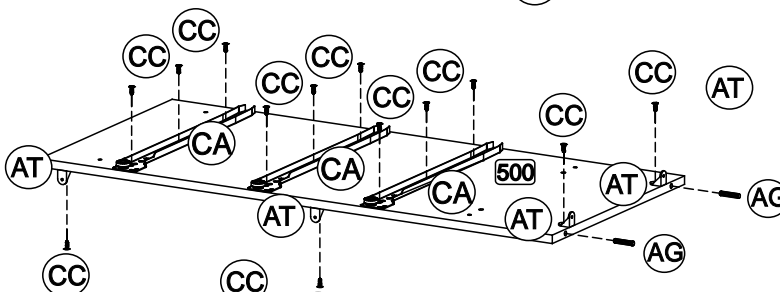
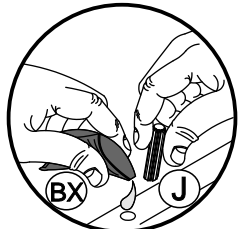
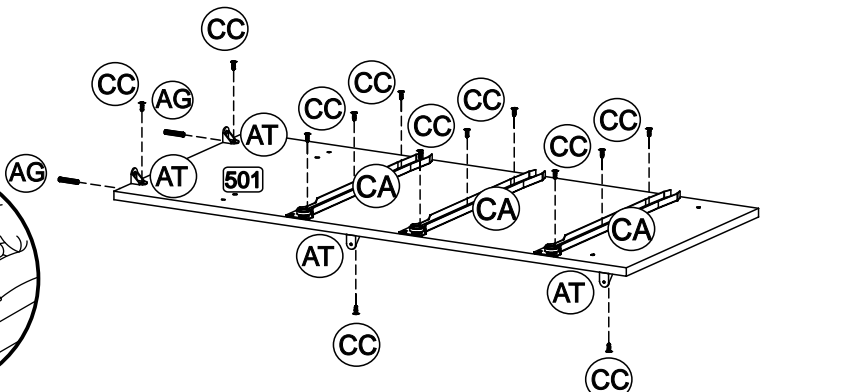
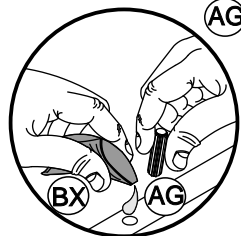
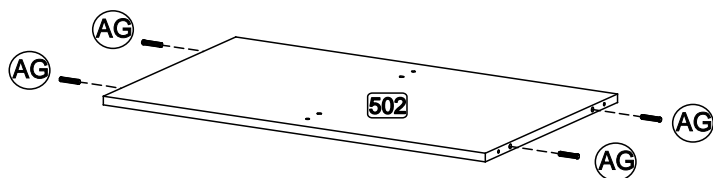
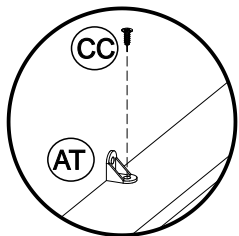

Passo
Paso
Step
06

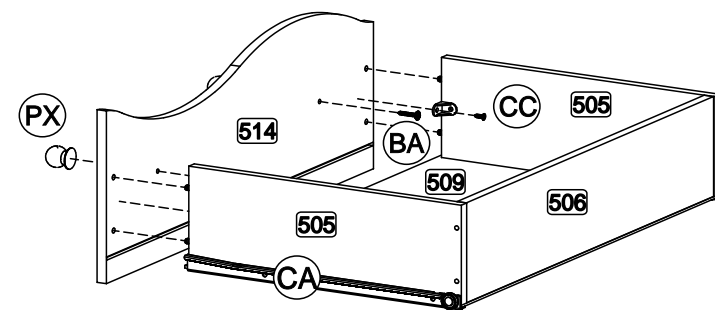
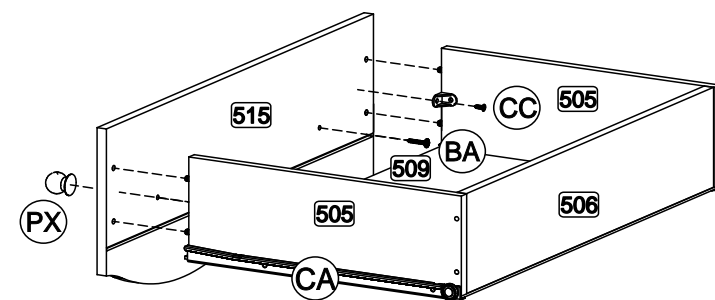
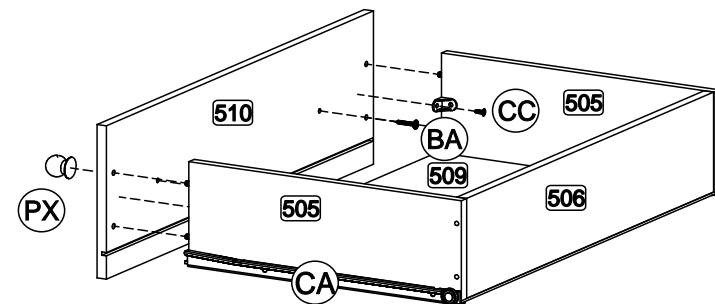
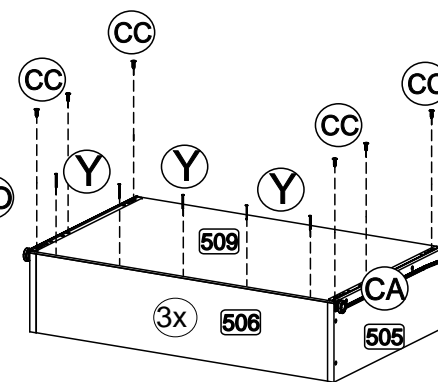
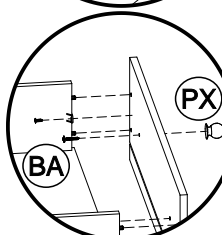
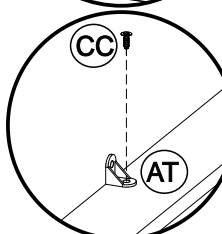
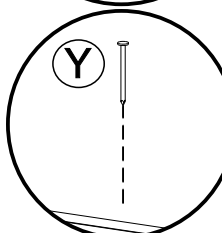
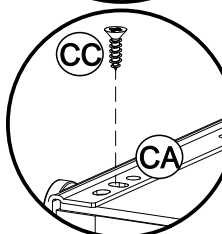
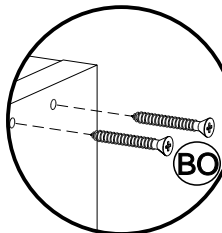
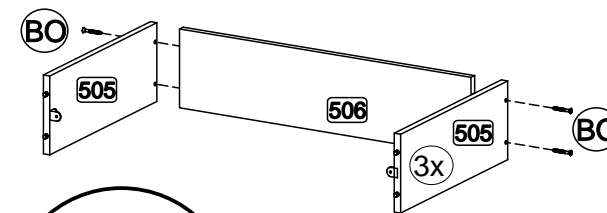

Passo
Paso
Step
05

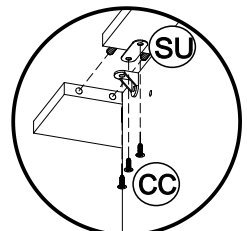
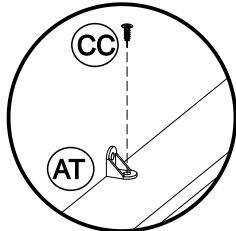
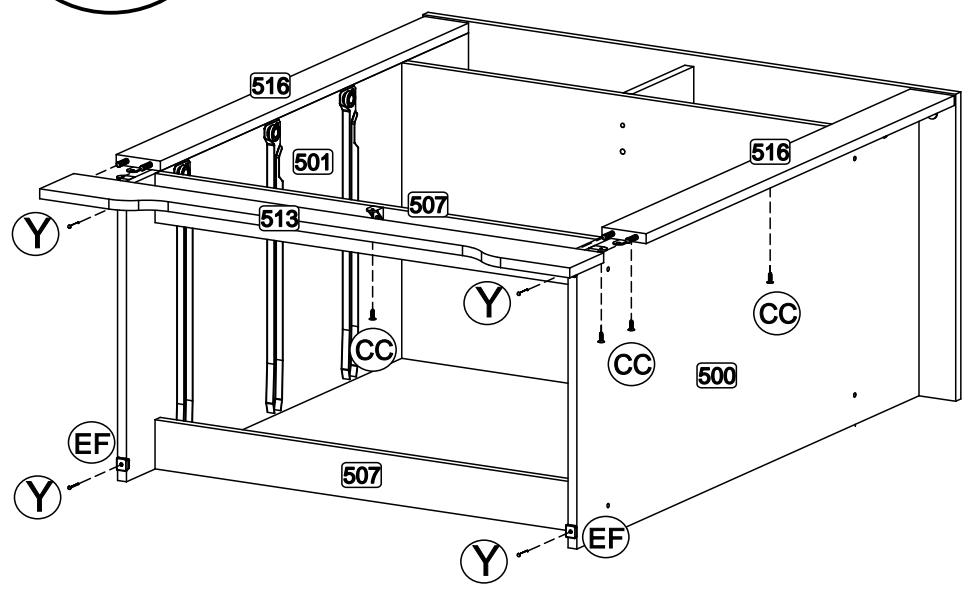
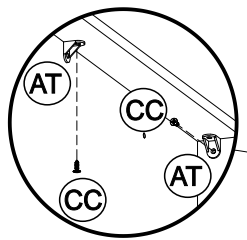
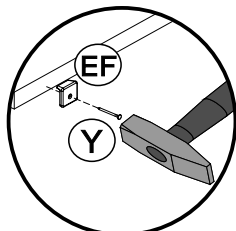

Passo
Paso
Step
01

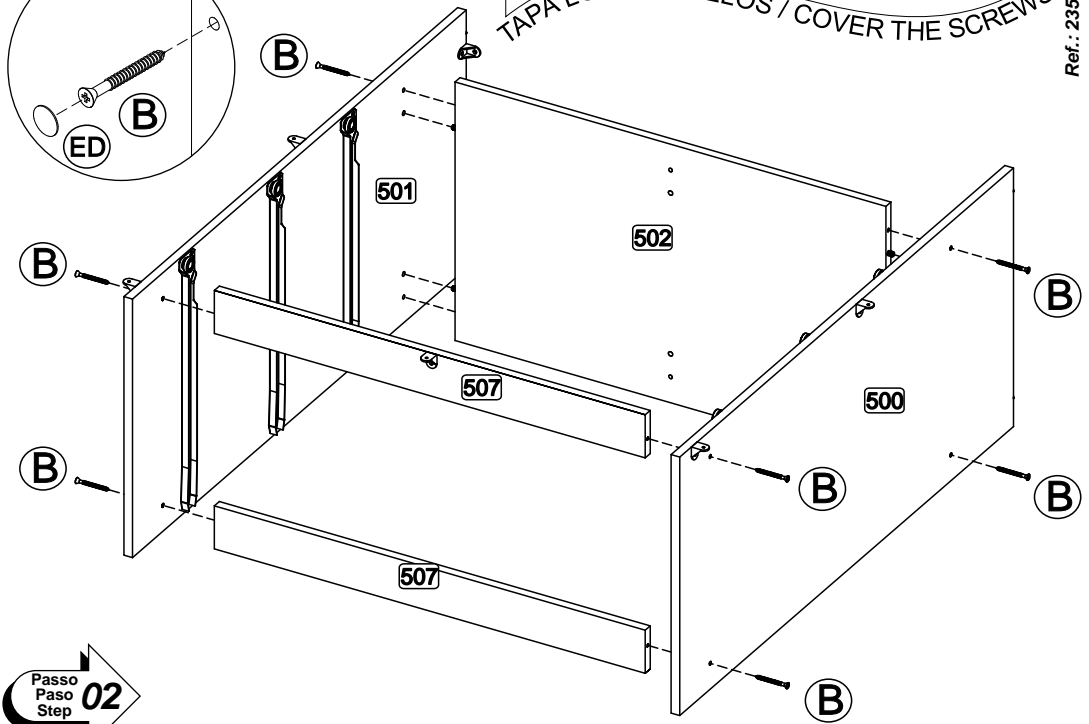
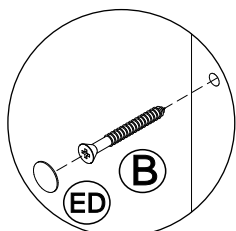

Passo
Paso
Step
02

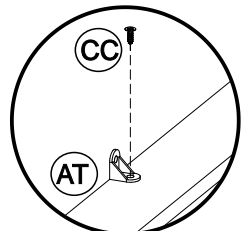
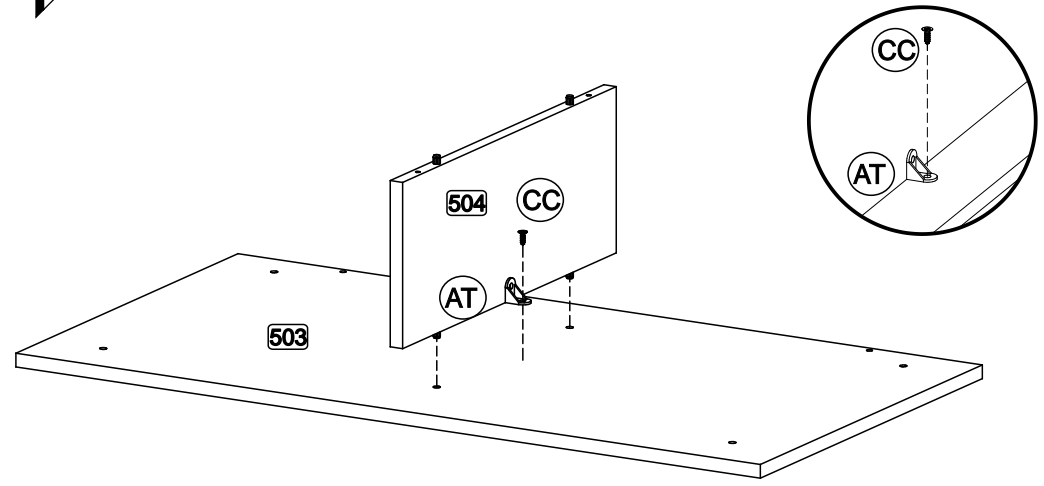

COBRIR OS PARAFUSOS
TAMPA ADESIVA
TAPA ADESIVA
STICKER
TAPA LOS TORNILLOS / COVER THE SCREWS

Ref.: 2352 -02/Março/2016 - Rev. 01

Passo
Paso
Step
03

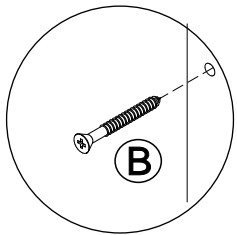
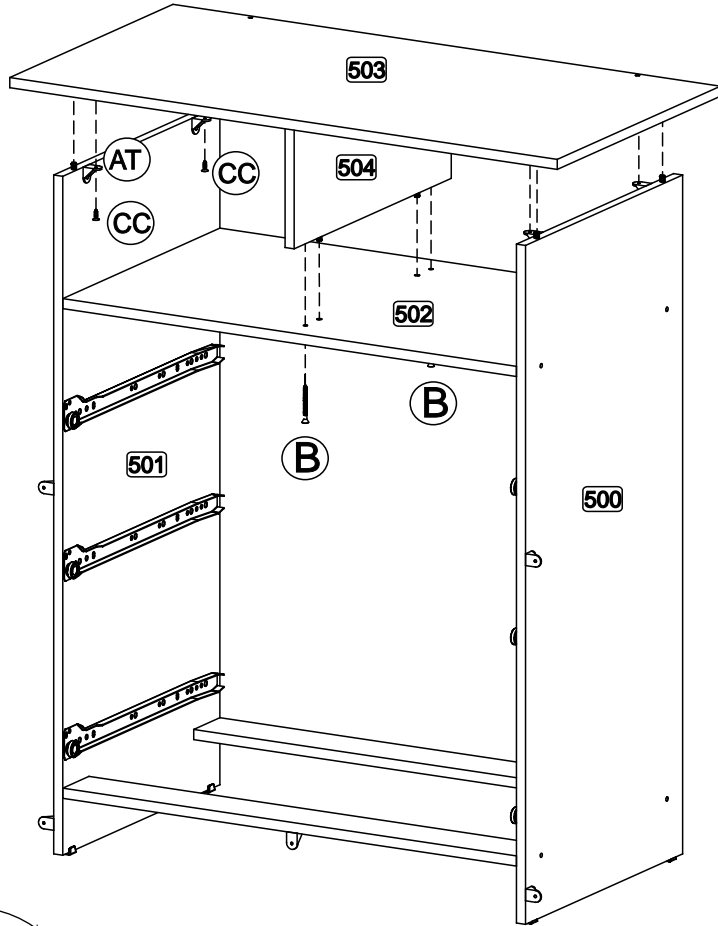
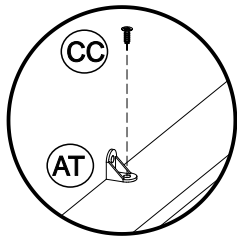

Passo
Paso
Step
04

