

Peso distribuido
de maneira
uniforme

Peso distribuido
de maneira
uniforme

Distributed
weight so
uniform

MULTIMÓVEIS
baby

Rua Carlos Dreher Neto, 1918, Fone: (54) 2102 4000, FAX: (54) 2102 4050
CEP 95700-000 - BENTO GONÇALVES - RS - BRASIL
CNPJ: 00.349.443/0001-92
e-mail: multimoveis@multimoveis.com / site: www.multimoveis.com

INSTRUÇÕES DE MONTAGEM
INSTRUCCIONES DE ARMADO
ASSEMBLY INSTRUCTIONS

REF.: 2343

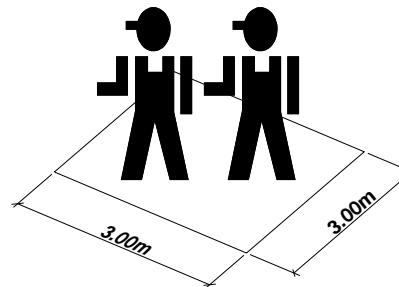
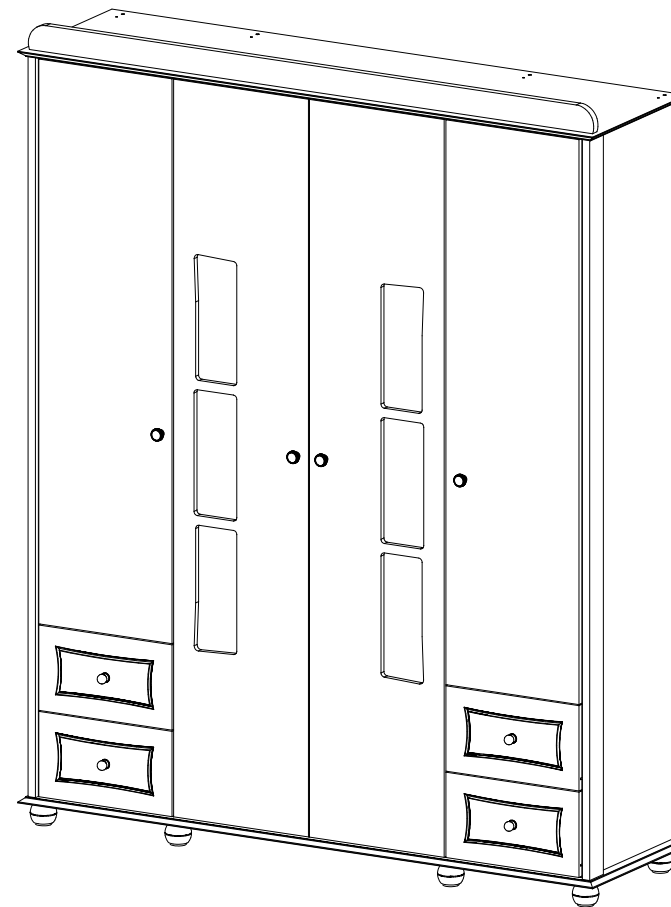

FERRAMENTAS NECESSÁRIAS
HERRAMIENTAS NECESARIAS
TOOLS NECESSARY

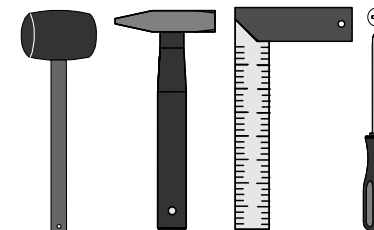

90 min



LISTA DE FERRAGENS / LISTA DE MATERIALES / HARDWARE LIST

B		27
D		16
E		128
H		56
J		04
K		20
L		16
N		22
O		30
P		22
V		04
X		09
Y		135
W		02
AA		14
AE		34
BA		08
BX		02
BW		08
ED		13
GO		04
PU		08
PX		09

Utilizar a régua abaixo para medir as ferragens:

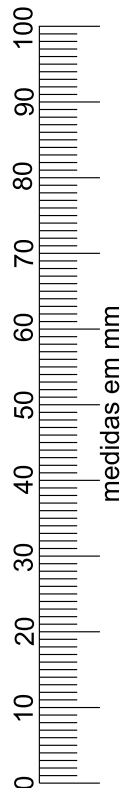

Passo
Paso
Step **09**

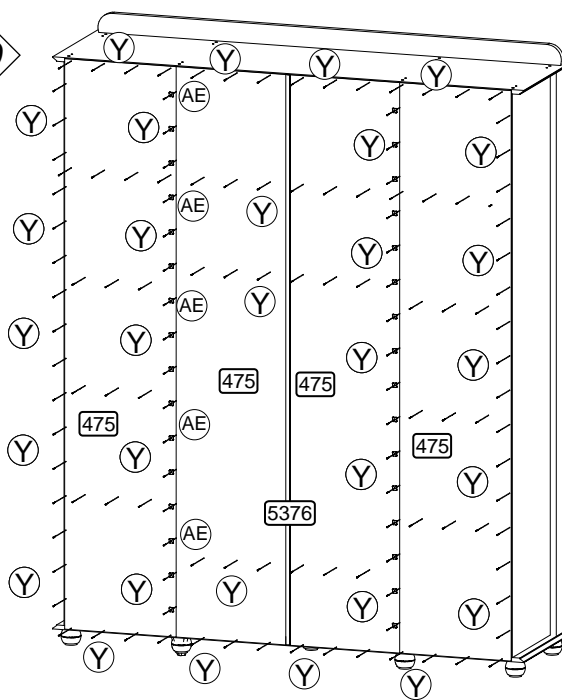

Passo
Paso
Step **10**

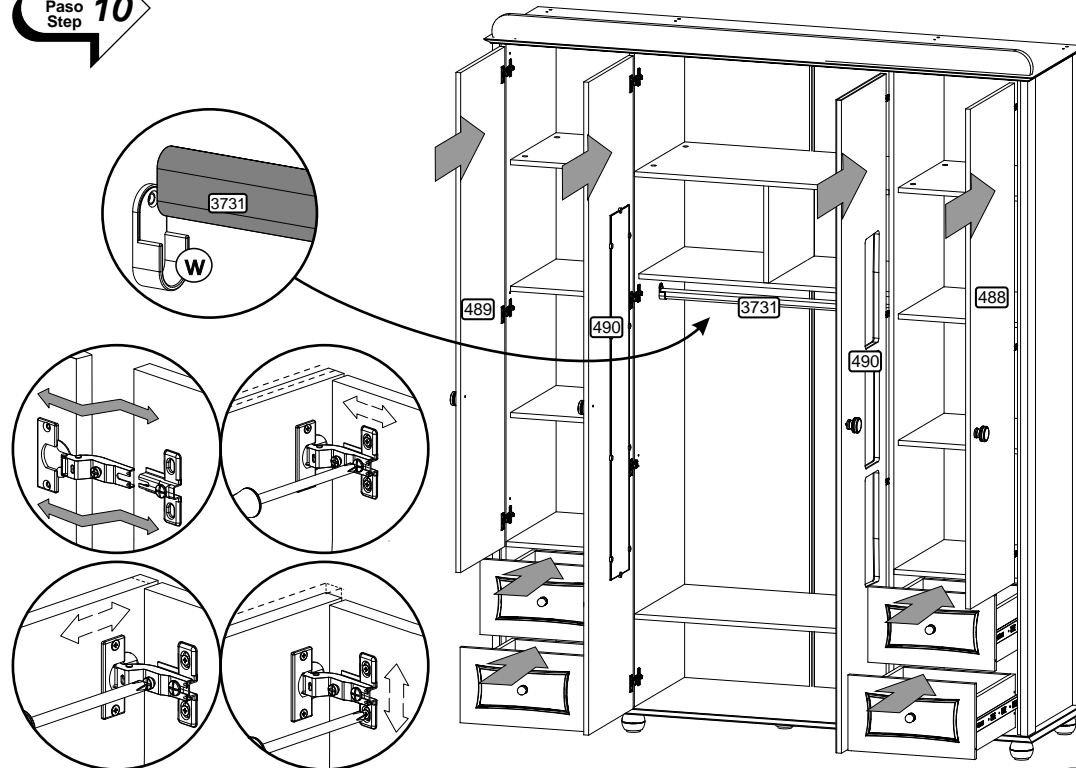

14x

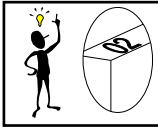
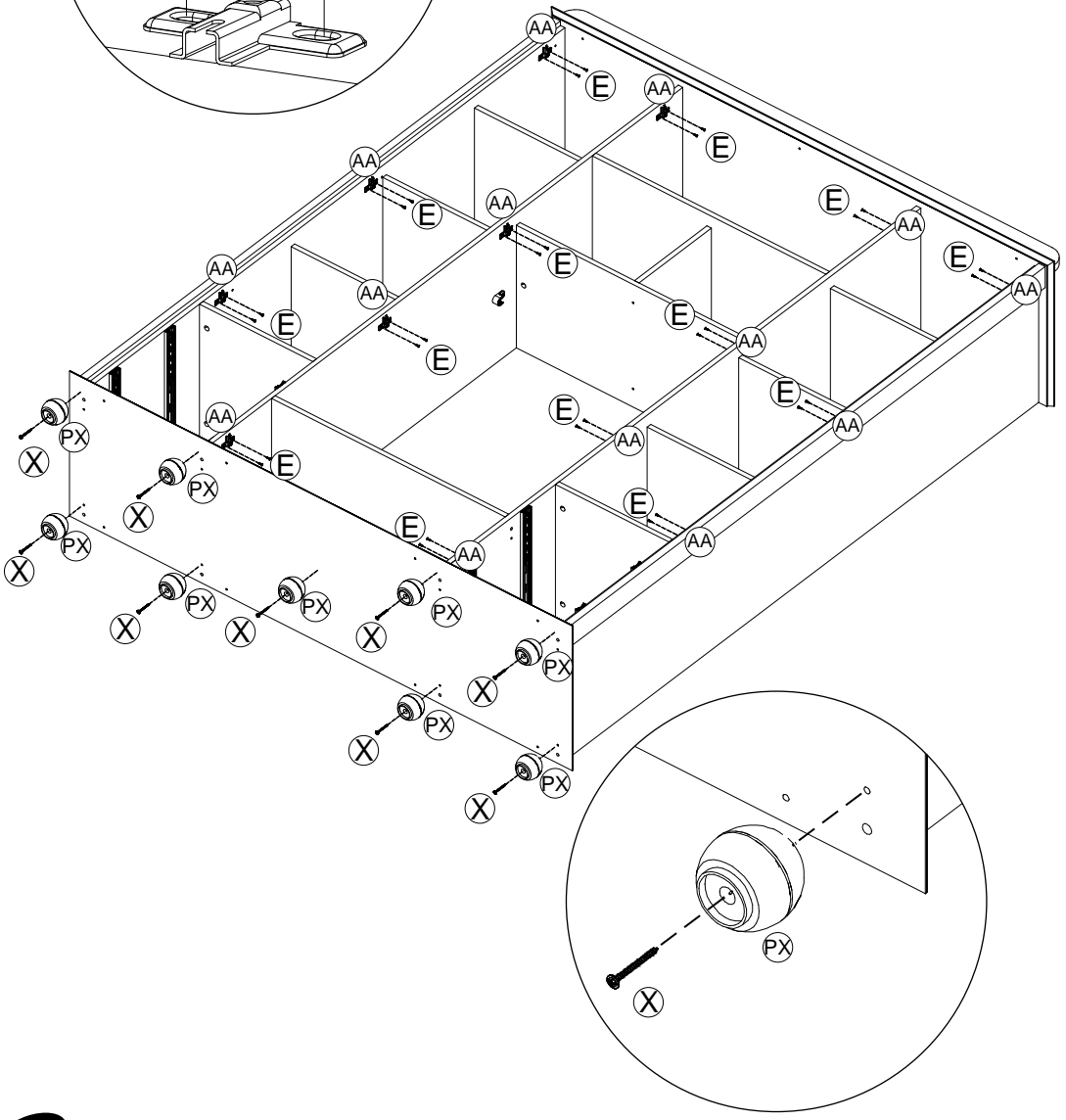
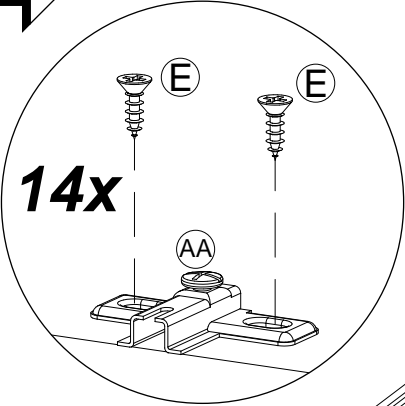

Senhor montador!
Informamos que a numeração das peças encontra-se no topo das mesmas conforme desenho acima.

Señor Armador!
Le informamos que la numeración de las piezas encuentranse arriba de las mismas, de acuerdo al modelo arriba.

Dear Assembler!
We inform you that the number of each piece is located on the top of it, according to the model shown above.

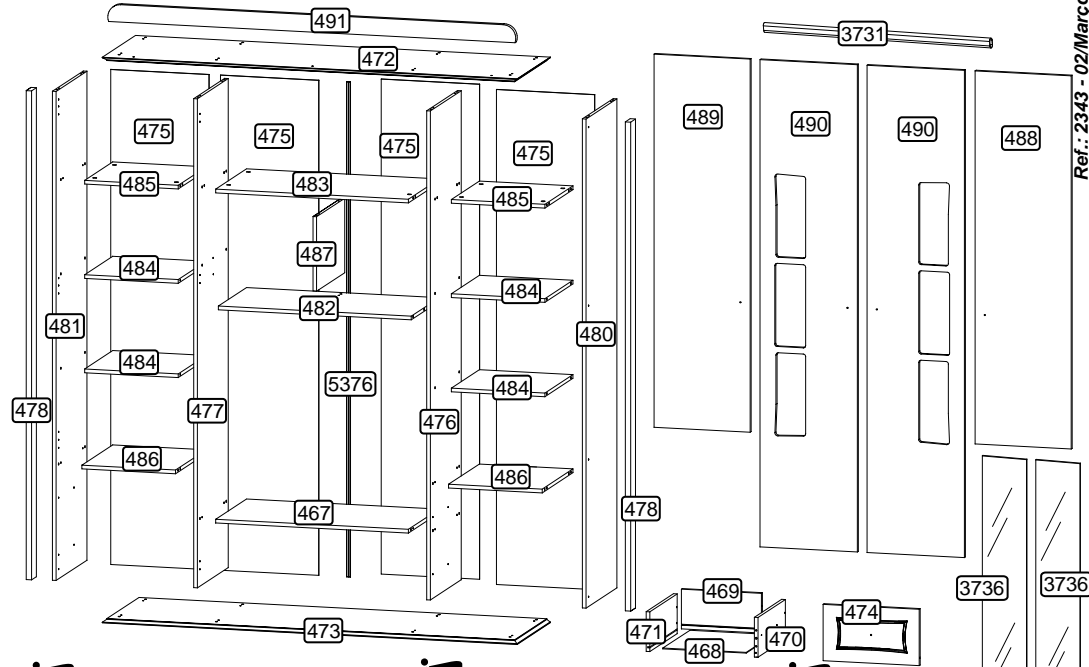

POR

LISTA DE PEÇAS

- | N° | |
|------|--------------------------------|
| 467 | - PRA TELEIRA INFERIOR MAIOR |
| 468 | - FUNDO DE GAVETA |
| 469 | - COSTA DE GAVETA |
| 470 | - LATERAL GAVETA DIREITA |
| 471 | - LATERAL GAVETA ESQUERDA |
| 472 | - TAMPO |
| 473 | - BASE |
| 474 | - FRENTE DE GAVETA |
| 475 | - COSTA |
| 476 | - DIVISÃO DIREITA |
| 477 | - DIVISÃO ESQUERDA |
| 478 | - MOLDURA LATERAL |
| 480 | - LATERAL DIREITA |
| 481 | - LATERAL ESQUERDA |
| 482 | - PRA TELEIRA CENTRAL |
| 483 | - PRA TELEIRA CENTRAL SUPERIOR |
| 484 | - PRA TELEIRA CAVILHA |
| 485 | - PRA TELEIRA |
| 486 | - TAMPO GAVETA |
| 487 | - DIVISÃO MENOR |
| 488 | - PORTA DIREITA |
| 489 | - PORTA ESQUERDA |
| 490 | - PORTA VAZADA |
| 491 | - MOLDURA SUPERIOR |
| 3731 | - CABIDEIRO |
| 5376 | - PERFIL I |
| 3736 | - VIDRO |

ESP

LISTA DE PIEZAS

- | N° | |
|------|----------------------------|
| 467 | - ESTANTE MAYOR INFERIOR |
| 468 | - FONDO CAJÓN |
| 469 | - RESPALDO CAJÓN |
| 470 | - LATERAL CAJÓN DERECHA |
| 471 | - LATERAL CAJÓN IZQUIERDA |
| 472 | - TAPA |
| 473 | - BASE |
| 474 | - FRENTE CAJÓN |
| 475 | - RESPALDO |
| 476 | - DIVISIÓN DERECHA |
| 477 | - DIVISIÓN IZQUIERDA |
| 478 | - MOLDURA LATERAL |
| 480 | - LATERAL DERECHA |
| 481 | - LATERAL IZQUIERDA |
| 482 | - ESTANTE CENTRAL |
| 483 | - ESTANTE CENTRAL SUPERIOR |
| 484 | - ESTANTE TARUGO |
| 485 | - ESTANTE |
| 486 | - TAPA CAJÓN |
| 487 | - DIVISIÓN MENOR |
| 488 | - PUERTA DERECHA |
| 489 | - PUERTA IZQUIERDA |
| 490 | - PUERTA CON AGUJERO |
| 491 | - MOLDURA SUPERIOR |
| 3731 | - PERCHA |
| 5376 | - PERFIL I |
| 3736 | - VIDRIO |

ENG

PART LIST

- | N° | |
|------|-----------------------|
| 467 | - LARGER LOWER SHELF |
| 468 | - BOTTOM DRAWER |
| 469 | - DRAWER BACK |
| 470 | - RIGHT DRAWER SIDE |
| 471 | - LEFT DRAWER SIDE |
| 472 | - TOP |
| 473 | - BASE |
| 474 | - FRONT DRAWER |
| 475 | - BACK |
| 476 | - RIGHT DIVISION |
| 477 | - LEFT DIVISION |
| 478 | - SIDE FRAME |
| 480 | - RIGHT SIDE |
| 481 | - LEFT SIDE |
| 482 | - CENTRAL SHELF |
| 483 | - UPPER CENTRAL SHELF |
| 484 | - BOLT SHELF |
| 485 | - SHELF |
| 486 | - DRAWER TOP |
| 487 | - SMALLER DIVISION |
| 488 | - RIGHT DOOR |
| 489 | - LEFT DOOR |
| 490 | - FRAME DOOR |
| 491 | - UPPER FRAME |
| 3731 | - HANGER |
| 5376 | - I PROFILE |
| 3736 | - GLASS |

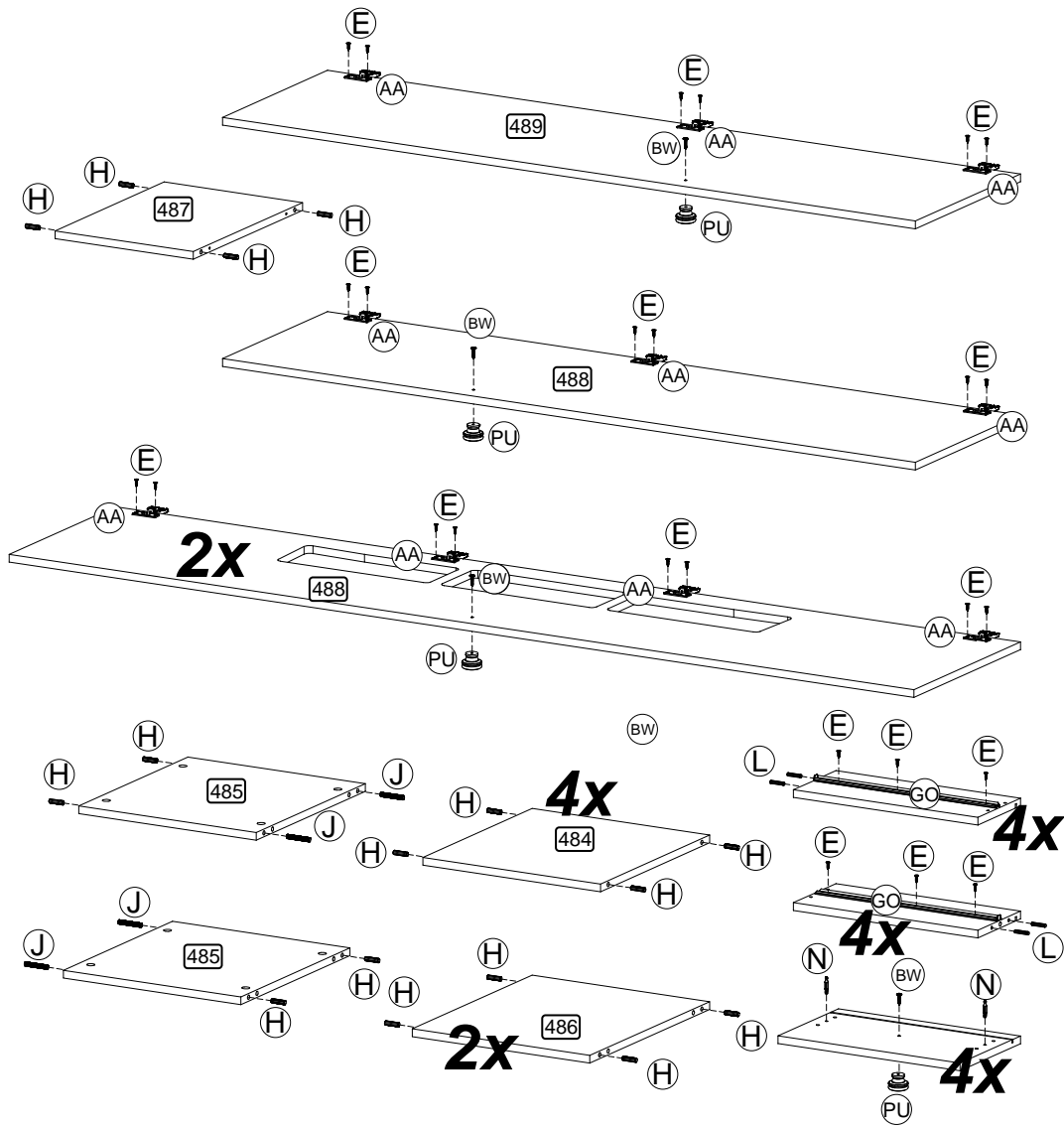

COBRIR OS PARAFUSOS
TAMPA ADESIVA
TAPA ADESIVA
STICKER
TAPA LOS TORNILLOS / COVER THE SCREWS

