

## LISTA DE PEÇAS / LISTA DE PIEZAS

Item	Caixa	Qty	Descrição / Descripción	Medidas (mm)
01	2/4	01	Rodapé frontal/ Pie frente	2085x65x15
02	3/4	03	Travessa do rodapé/ Carril pie	500x65x15
03	2/4	01	Rodapé traseiro/ Pie trasero	2085x65x15
04	1/4	01	Lateral esquerda/ Lado izquierdo	2195x537x15
05	2/4	01	Base/ Base	2086x537x15
06	3/4	01	Divisão do gaveteiro/ División de cajones	700x445x15
07	3/4	01	Tampo do gaveteiro/ Cubierta de cajones	1035x450x15
08	3/4	01	Divisão central/ División central	2050x450x15
09	1/4	01	Prateleira maior/ Estante más	1035x445x15
10	2/4	01	Travessa suporte/ Carril apoyo	1035x65x12
11	1/4	01	Lateral direita/ Lado derecho	2195x537x15
12	3/4	01	Divisão menor/ División menos	1200x450x15
13	1/4	02	Prateleira menor/ Estante menos	501x445x15
14	3/4	01	Tampo do gaveteiro/ Cubierta de cajones	1035x450x15
15	1/4	01	Prateleira maior/ Estante más	1035x445x15
16	2/4	01	Travessa suporte/ Carril apoyo	1035x65x12
17	2/4	01	Tampo superior/ Cubierta superior	2086x537x15
18	2/4	04	Fundo/ Fondo	2080x524x3
19	1/4	01	Moldura superior/ Marco superior	2174x80x15
20	1/4	02	Moldura lateral/ Marco lateral	2113x70x15
21	1/4	01	Ripa lateral/ Lado ripa	520x54x25
22	4/4	01	Porta de correr/ Puerta corredera	2034x1060x12
23	2/4	03	Moldura da porta/ Marco de la puerta	1038x15x9
24	4/4	01	Porta de correr espelho/ Puerta corredera espejo	2034x1060x12
25	1/4	03	Frente de gaveta/ Frente de cajón	625x145x12
26	3/4	06	Lado de gaveta/ Cajón lateral	350x122x12
27	4/4	03	Fundo de gaveta/ Fondo de cajón	595x349x3
28	1/4	03	Ripa de trás/ Ripa espalda	584x122x12
29	-/-	04	Espelho 500x450x3mm com Furo/ Espejo 500x450x3mm con el agujero	500x450x3

## SISTEMA DE MONTAGEM

O sistema de montagem dos produtos Henn, funciona de acordo com a ordem crescente dos números indicados no desenho. Ex: 01, 02, 03, 04... até a conclusão da montagem.

## AVISO

Para limpeza de seu móvel, use uma flanela seca ou umedecida, e não utilize produtos químicos que possam danificar seu produto.

## SISTEMA DE MONTAJE

El sistema de montaje de productos Henn, funciona de acuerdo con el orden ascendente de los números indicados en el dibujo. Por ejemplo, 01, 02, 03, 04 ... hasta la finalización del montaje.

## ADVERTENCIA

Para su móvil de limpieza, use una flanela seca o húmeda, y no utilice productos químicos que pueden dañar su producto.



www.henn.com.br  
henn@henn.com.br  
55 49 3674 3500  
Mondai/SC - Brasil

## INSTRUÇÃO DE MONTAGEM INSTRUCCIONES DE MONTAJE

### Roupeiro 02 Portas Correr Dakar / Armario Puertas 02 Running Dakar

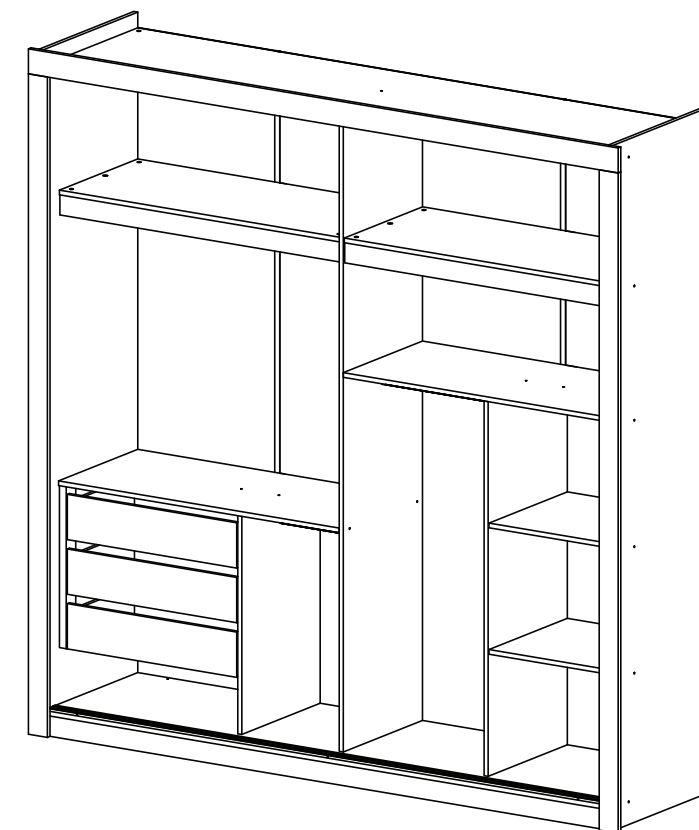
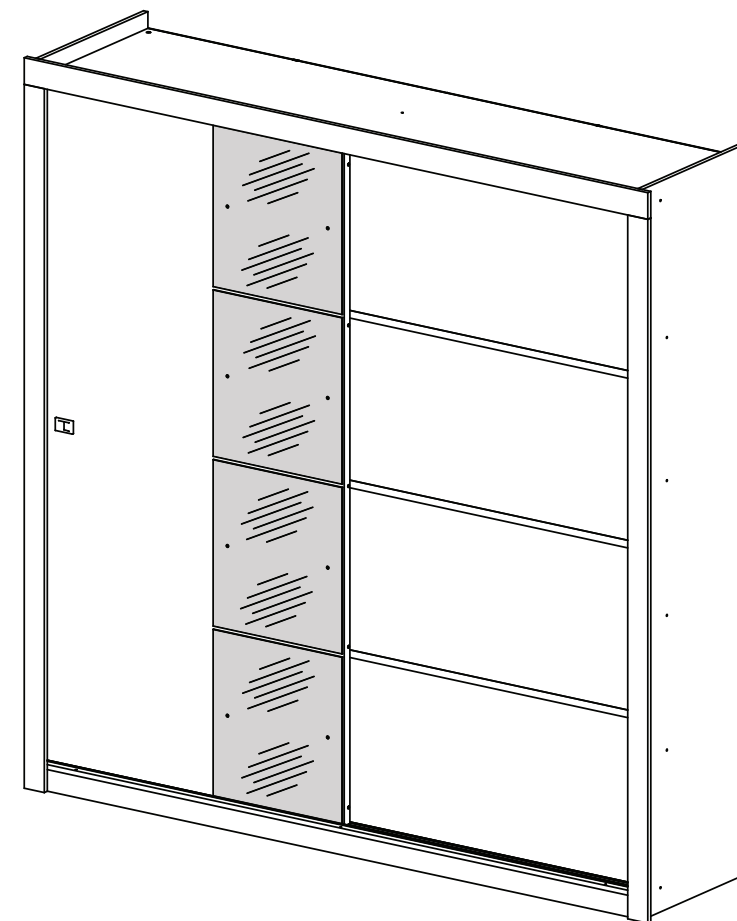

- D125-10 - Branco
- D125-12 - Malbec
- D125-63 - Malbec/Fendi

#### REQUISITOS PARA MONTAGEM REQUISITOS PARA LA ASAMBLEA

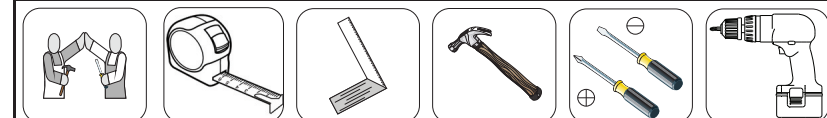

Imagens meramente ilustrativas / Imágenes meramente ilustrativas

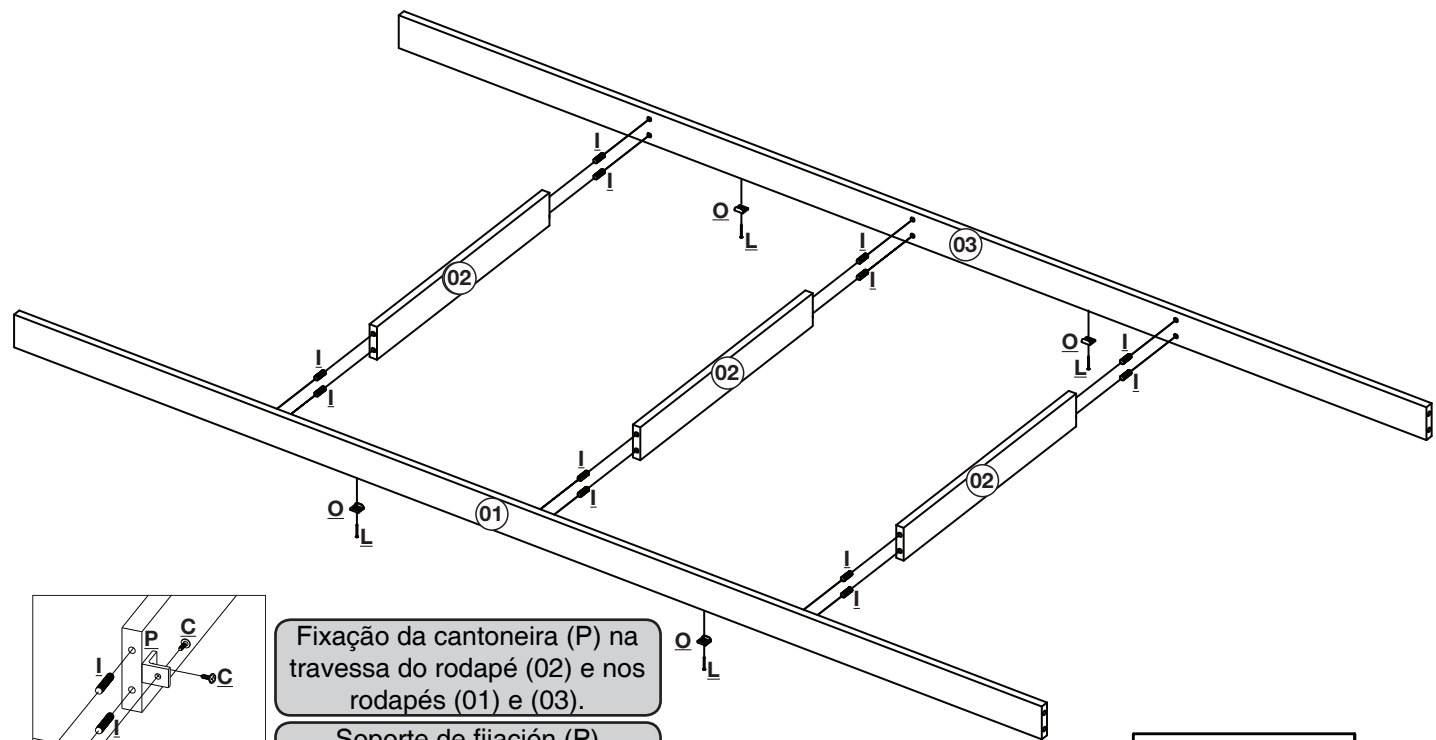

Fixação da cantoneira (P) na travessa do rodapé (02) e nos rodapés (01) e (03).

Soporte de fijación (P) haz pie de página (02) y zócalos (01) y (03).

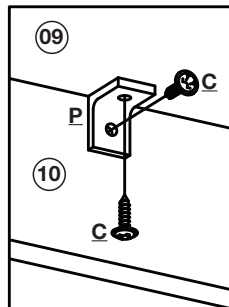
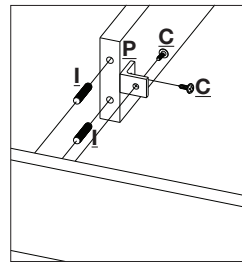

Colocar 01 cantoneira (P) com os parafusos 3,5x14 (C) na travessa suporte (10) com a prateleira maior (09).

Coloque 01 suporte (P) 3,5x14 con tornillos (C) soporte de popa (10) con útil más larga (09).

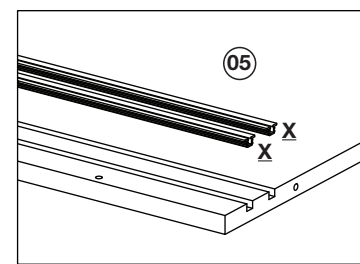

Utilizar os trilhos de alumínio (X) na base (05).

El uso de rieles de aluminio (X) en la base (05).

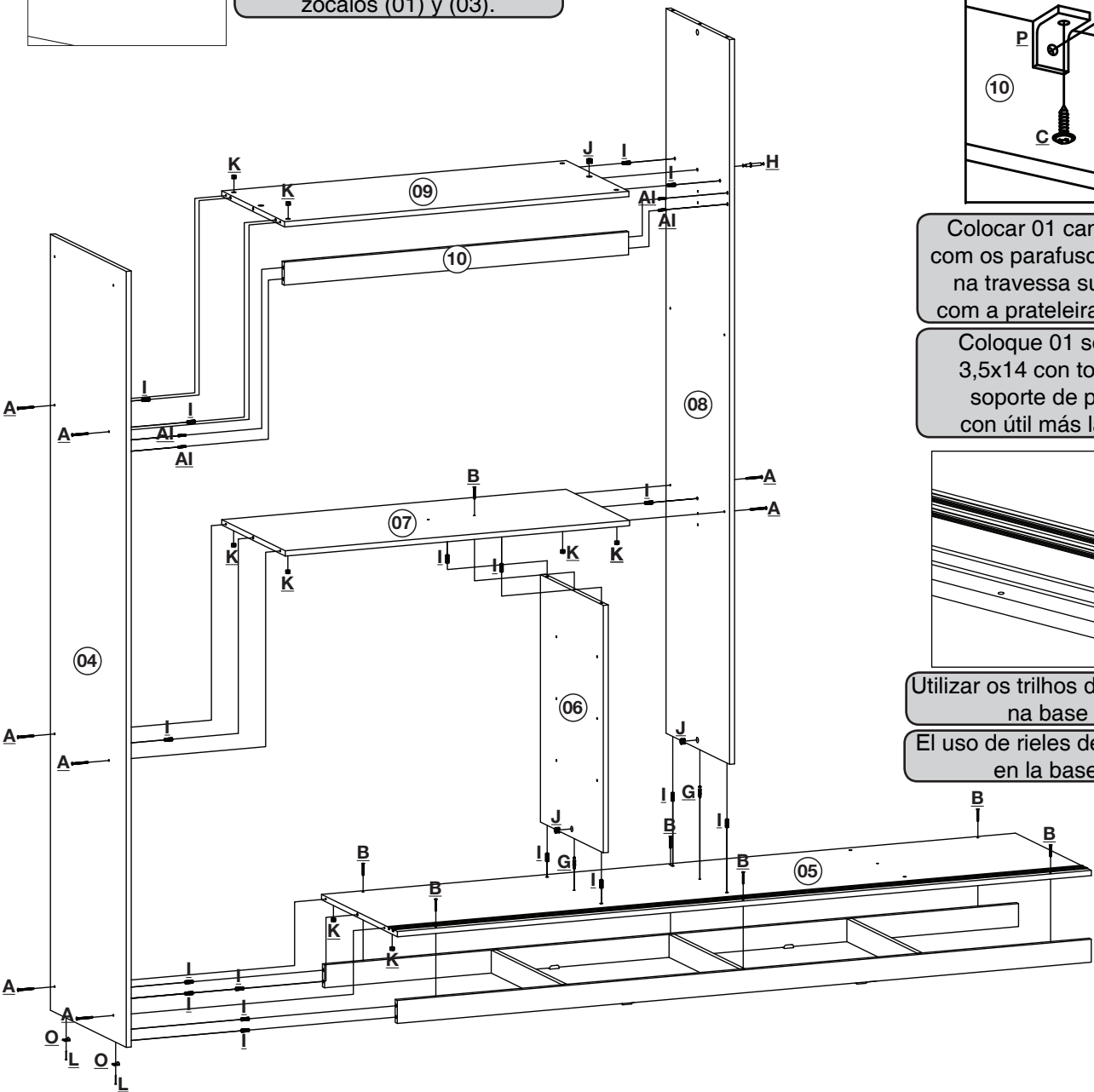

LISTA DE FERRAGENS

<b>A</b> 28. Paraf. 4,5x50mm CHT.	<b>B</b> 11. Paraf. 4,0x35mm CHT.	<b>C</b> 52. Paraf. 3,5x14mm FLA.	<b>D</b> 54. Paraf. 3,5x12mm CHT.	<b>E</b> 12. Paraf. 3,0x18mm PAN.
<b>F</b> 06. Paraf. 3,0x16mm CHT.	<b>G</b> 04. Parafuso minifix	<b>H</b> 01. Conector de haste dupla	<b>I</b> 52. Cavilha 8x25mm	<b>J</b> 06. Tambor minifix
<b>K</b> 28. Porca cilíndrica	<b>L</b> 14. Prego 12x12 anelado	<b>M</b> 129. Prego 10x10	<b>N</b> 14. Fixador de fundo	<b>O</b> 08. Sapata "L" 15x15
<b>P</b> 14. Cantoneira plástica	<b>Q</b> 06. Cantoneira suporte triangular	<b>R</b> 02. Suporte de metal	<b>S</b> 13. Conector de montagem	<b>T</b> 06. Suporte cabideiro
<b>U</b> 03. Corrediça metal 350mm	<b>V</b> 02. Perfil "H" 2068mm	<b>W</b> 02. Trilho 2086mm PVC	<b>X</b> 02. Trilho de alumínio 2085mm	<b>Y</b> 01. Kit roldana CM12- 02 portas
<b>Z</b> 01. Cabideiro alum. 356mm	<b>AA</b> 01. Cabideiro alum. 513mm	<b>AB</b> 01. Cabideiro alum. 1029mm	<b>AC</b> 01. Sachê de cola	<b>AD</b> 01. Etiqueta resinada
<b>AE</b> 06. Adesivo tapa parafuso 17mm	<b>AF</b> 37. Adesivo tapa parafuso 10mm	<b>AG</b> 03. Distânciador de corrediça	<b>AH</b> 16. Batente PVC	<b>AI</b> 32. Cavilha 5x25mm
<b>AJ</b> 01. Puxador ganges	<b>AK</b> 04. Perfil antiempeno 2032mm	<b>AL</b> 20. Adesivo tapa parafuso perfil	<b>AM</b> 01. Giz de correção	<b>AN</b> 01. Paraf. 3,5x12mm FLA.

A ferragem "AK" só será usada em caso de pedido de assistência técnica, pois o perfil antiempeno "U" já vem montado nas portas de fábrica.

Hardware "AK" sólo se utilizará en caso de solicitud de servicio debido a que el perfil antiempeno "U" ya está montado en las puertas de la fábrica.

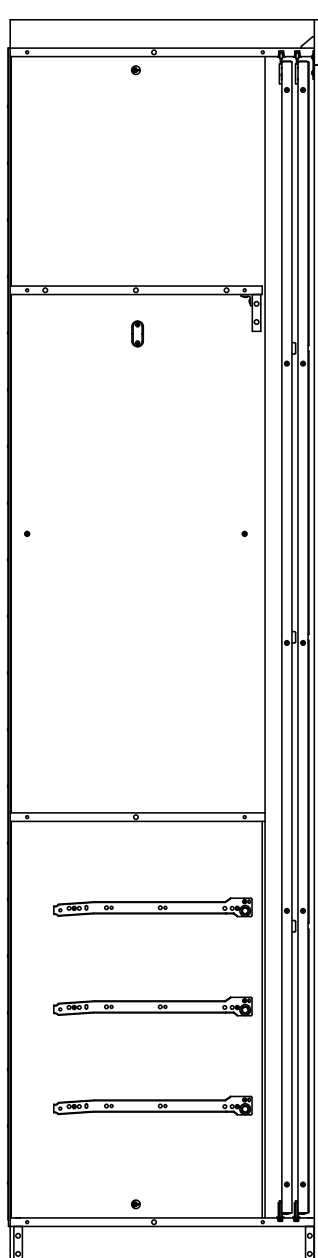

Para a colocação das portas nos trilhos encaixe primeiro a porta no trilho de PVC superior (W) e em seguida no trilho de alumínio inferior (X).

Para la colocación de las puertas en el primer carril de montaje de la puerta en el carril superior PVC (W) y luego el riel de aluminio inferior (X).

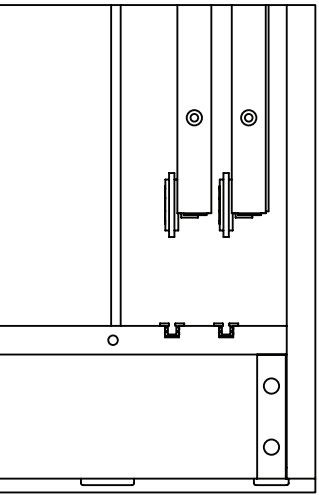
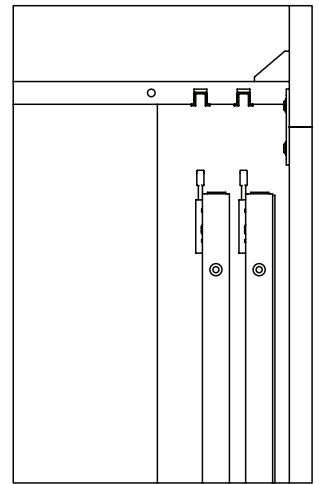

A porta de correr com espelho deverá ser encaixada no trilho externo, e a porta de correr deverá ser encaixada no trilho interno.

La puerta corredera con espejo debe montarse en el carril exterior, y la puerta corredera se debe montar en el carril interior.

Repetir montagem 3x.

Repita el montaje 3x.

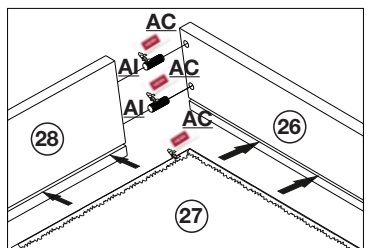
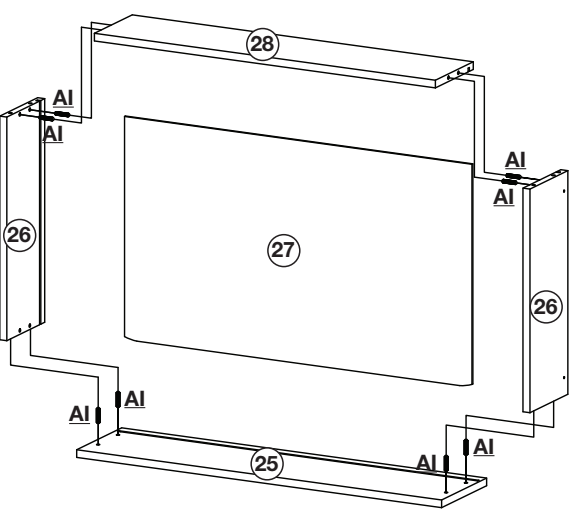

Utilize o sachê de cola (AC) nas cavilhas (AI) e nos frisos das gavetas.

Utilice bolsita de pegamento (AC) los pasadores (AI) y las perlas los cajones.

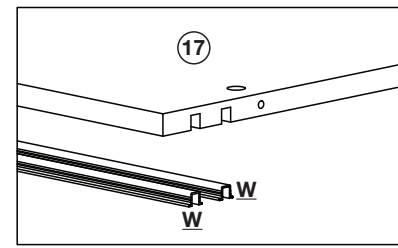
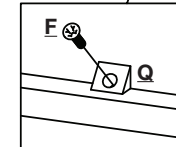
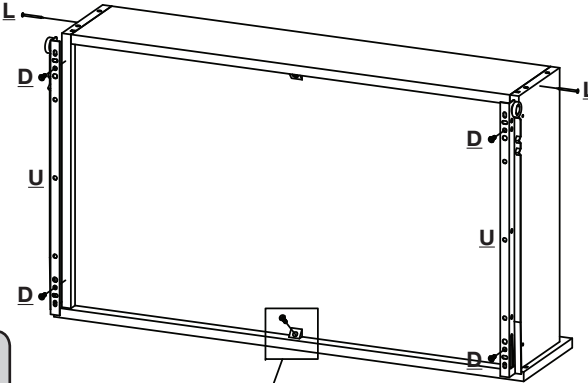
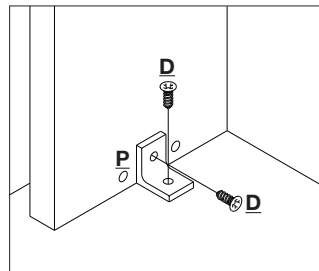

Utilizar os trilhos de PVC (W) na tampo superior (17).

Uso de los carriles de PVC (W) la tapa superior (17).

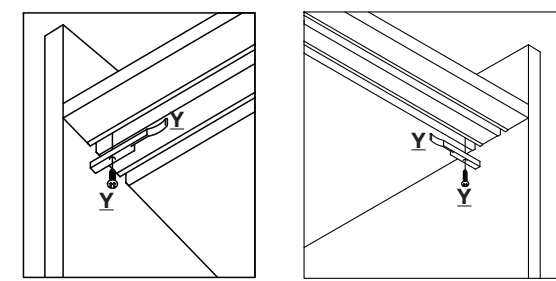

Colocar os freios do kit (Y) nos trilhos de PVC (W) e encostado na lateral do móvel.

Colocar el kit de frenos (Y) en los rieles de PVC (W) que se inclina contra la pared del gabinete.

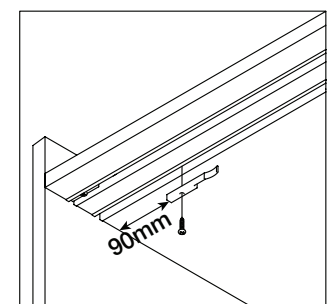

Colocação do freio no trilho de trás 90mm afastado da lateral.

Freno de puesta en Rail 90mm de distancia de la parte trasera.

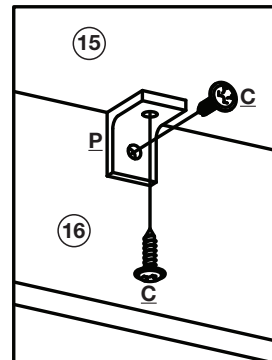
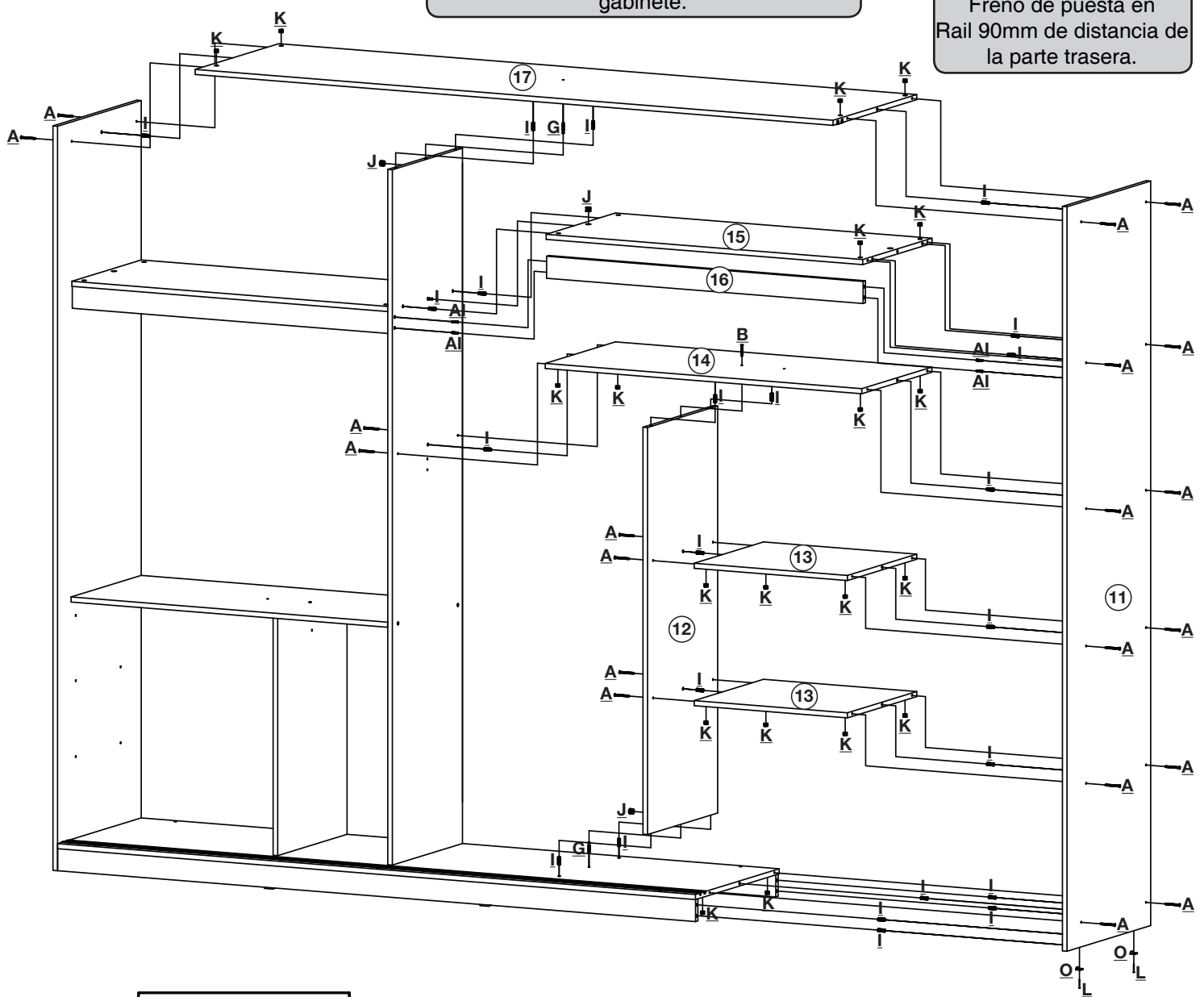

Colocar 01 cantoneira (P) com os parafusos 3,5x14 (C) na travessa suporte (16) na prateleira maior (15).

Coloque 01 soporte (P) 3,5x14 con tornillos (C) soporte de popa (16) con útil más larga (15).

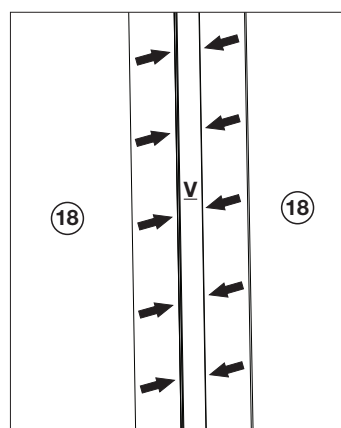
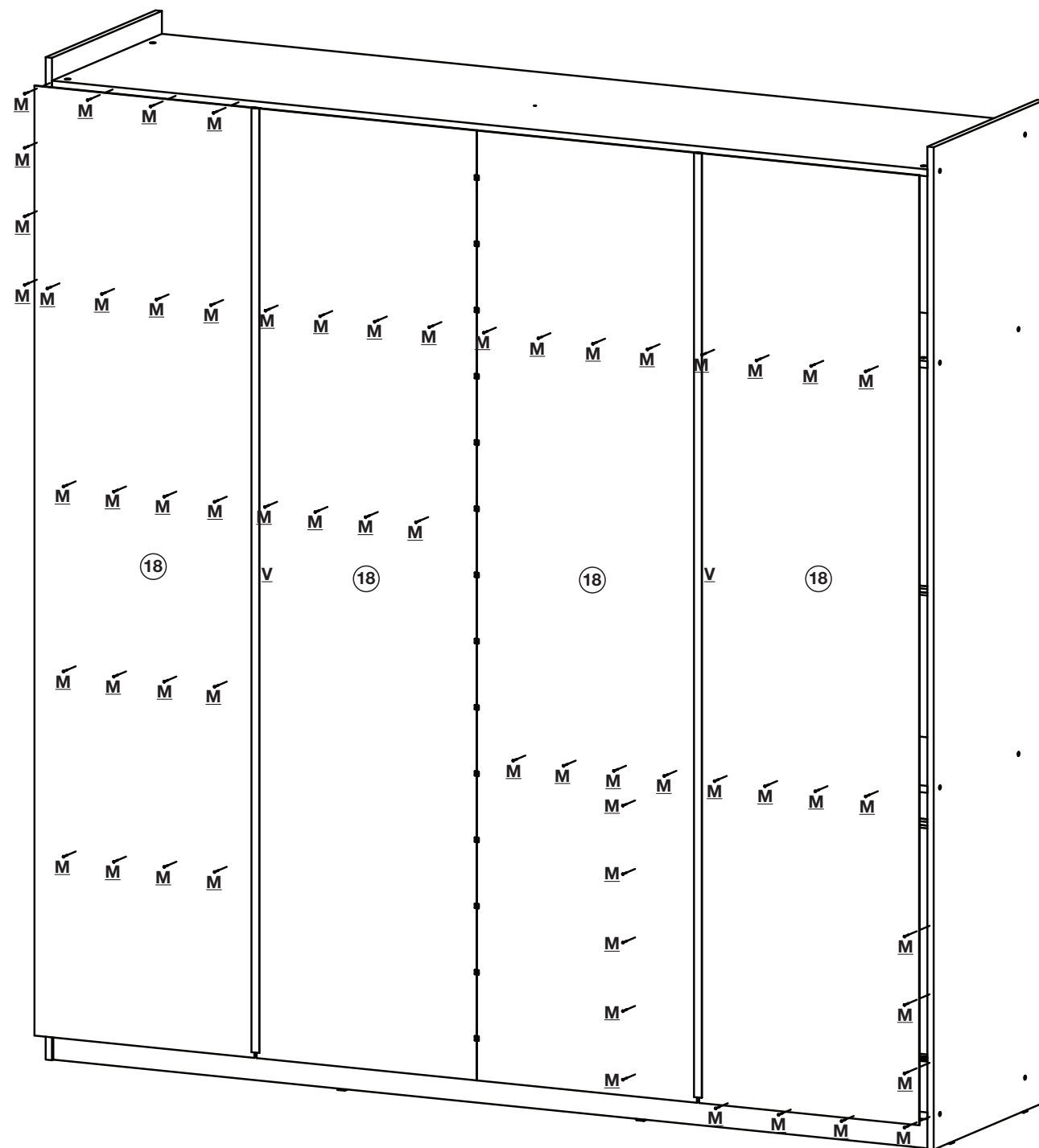

Colocação do perfil "H" 2068mm (V).

Colocar el perfil 2068mm "H" (V).

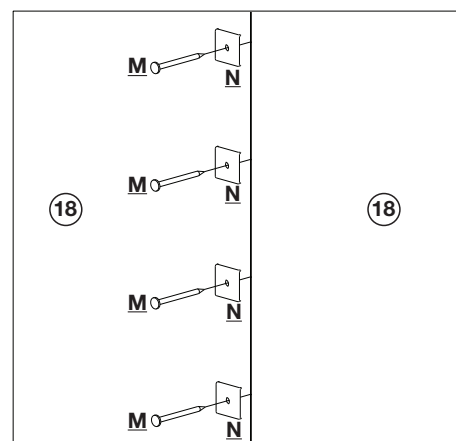

Colocação dos fixadores de fundo (N).

La colocación de los elementos de sujeción inferiores (N).

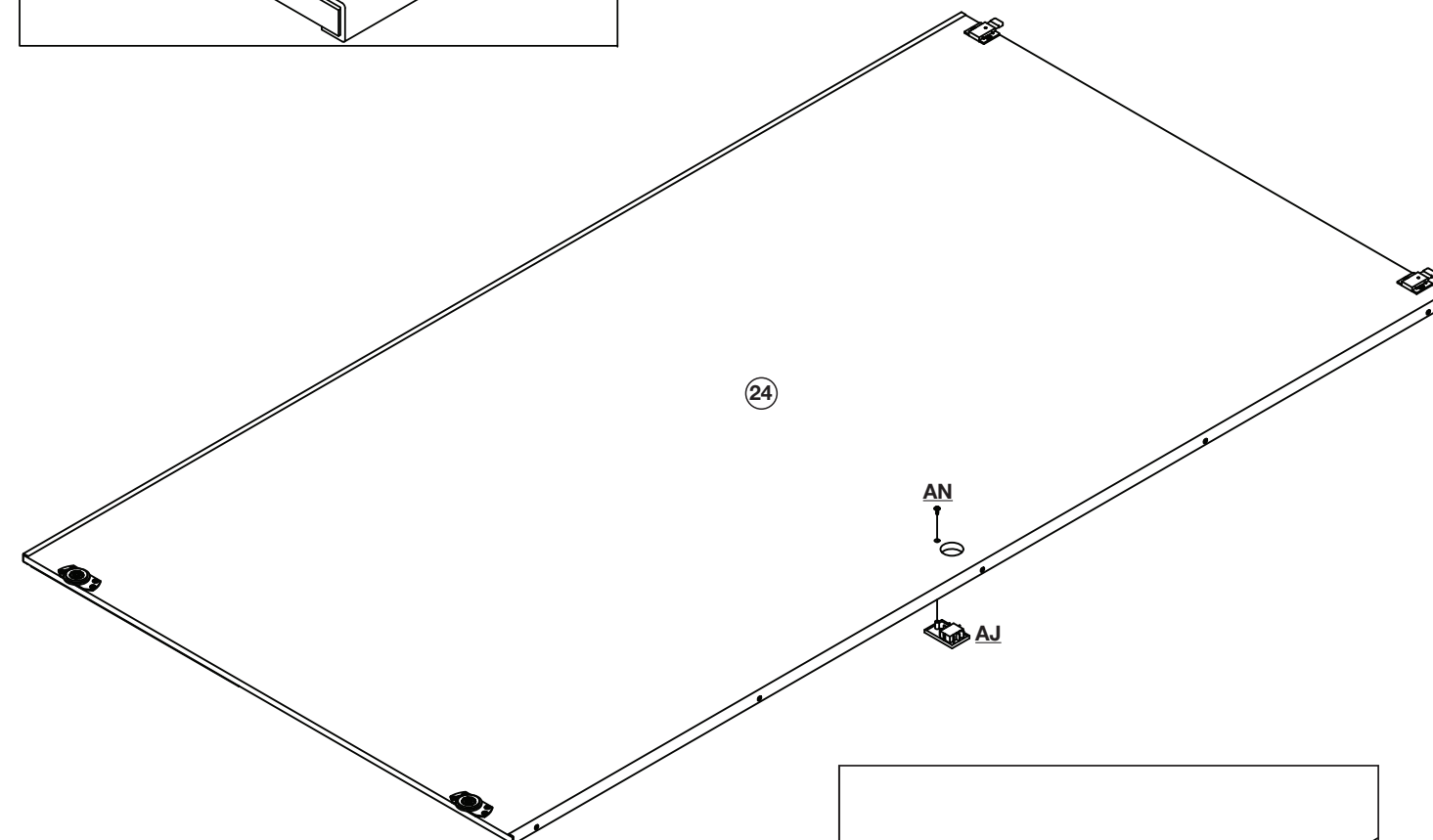
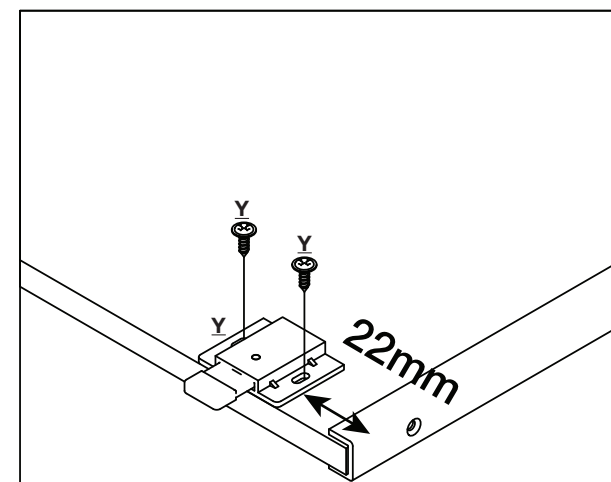

Após a regular as portas fixar o rodízio com os parafusos do kit (Y).

Después de puertas regulares arreglar rotación con los tornillos del kit (Y).

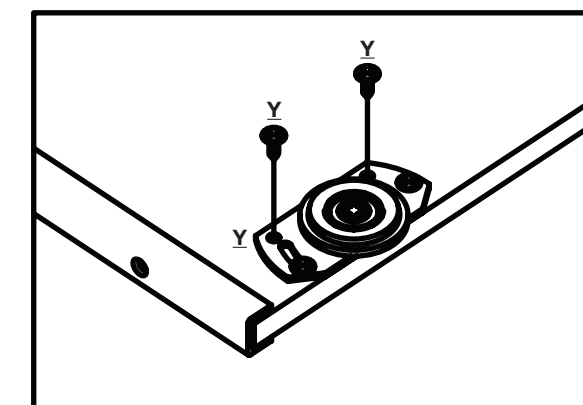
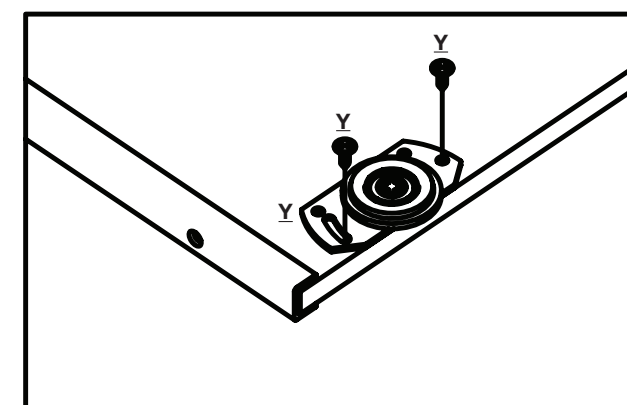
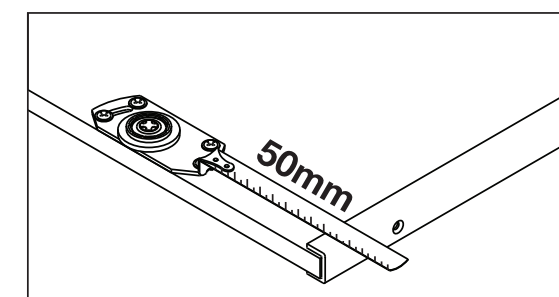

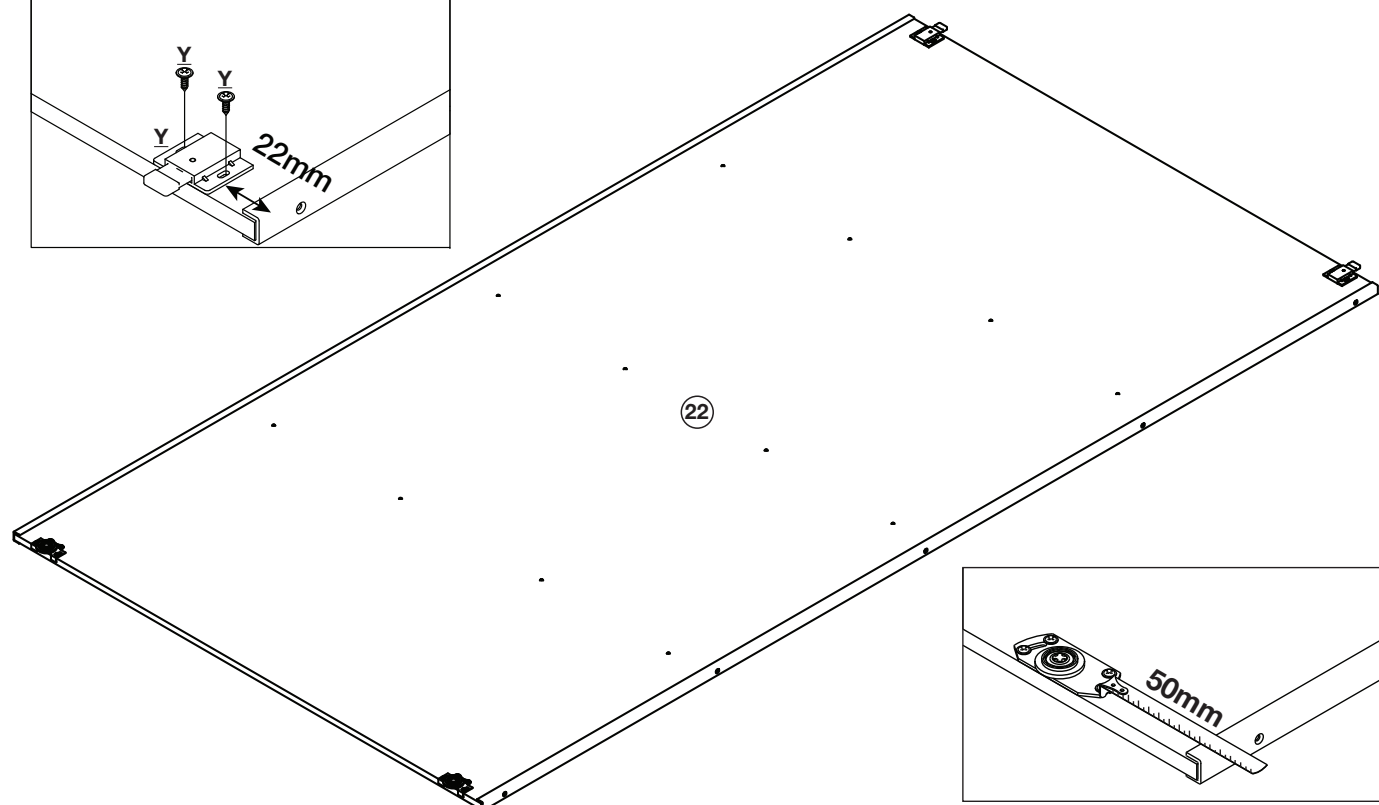
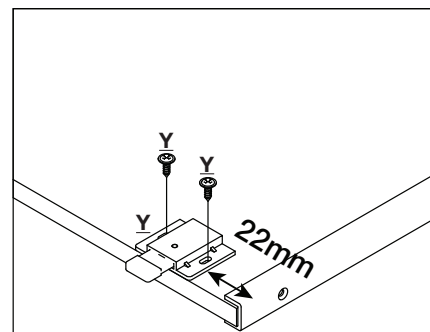
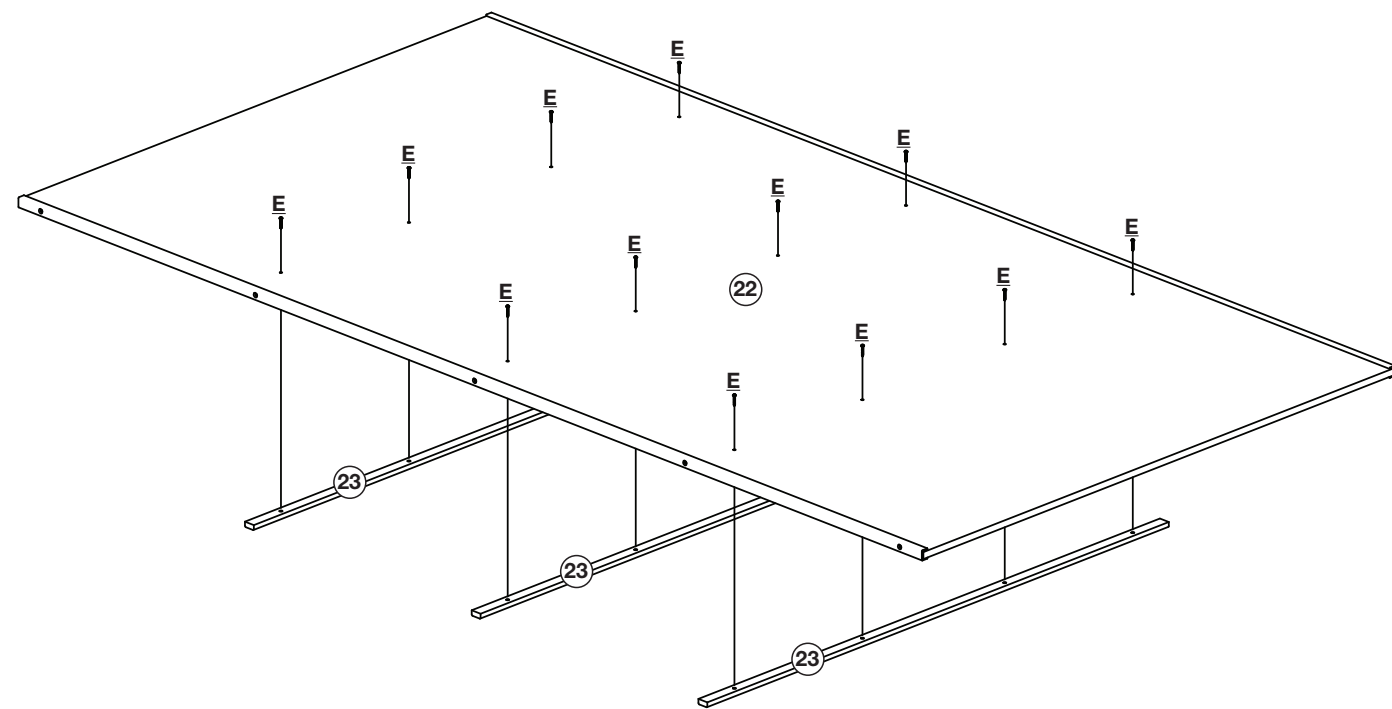

Após a regular as portas fixar o rodízio com os parafusos do kit (Y).

Después de puertas regulares fijar la rotación con los tornillos del kit (Y).

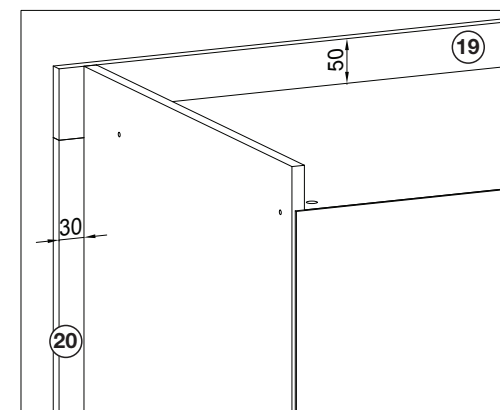
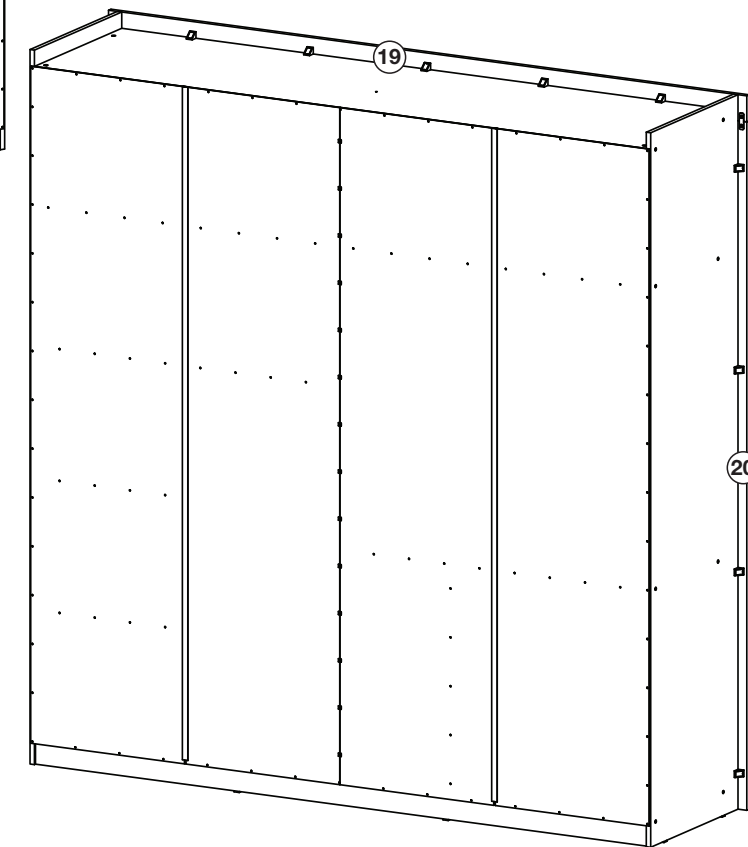
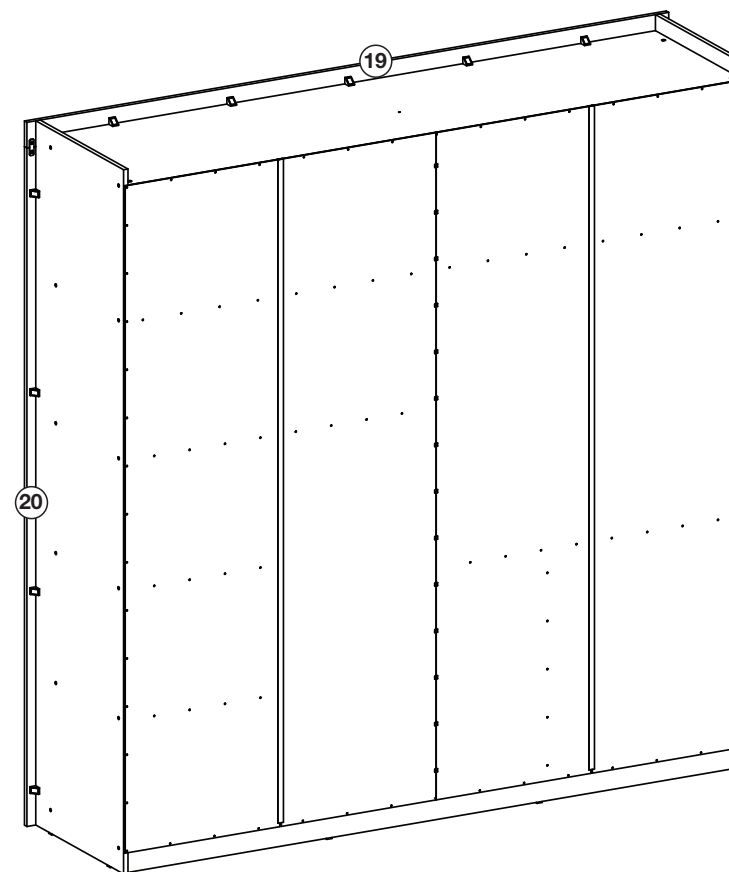
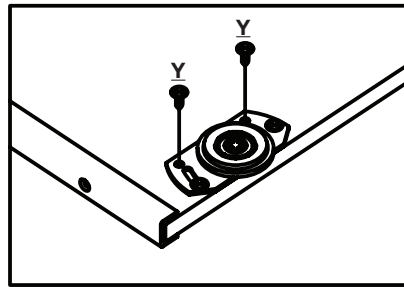
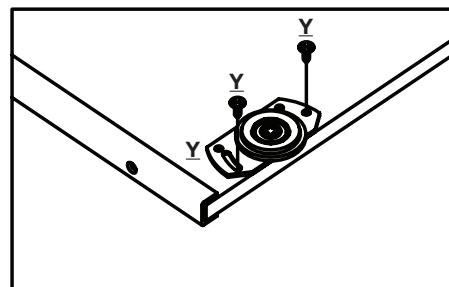

Medidas indicadas para a  
fixação das molduras (19) e (20)

Medidas indicadas a  
la fijación de los marcos (19) y (20)

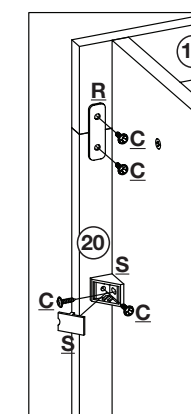

Utilizar o conector de montagem (S) para  
fixar as molduras (19) e (20) no móvel.

Uso del conector de montaje (S) para fijar  
los marcos (19) y (20) en el gabinete.

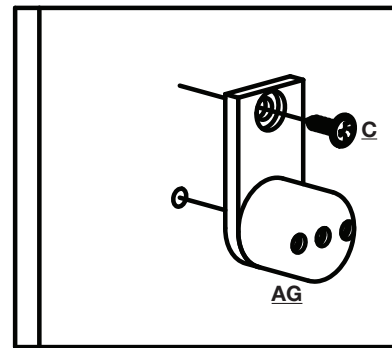
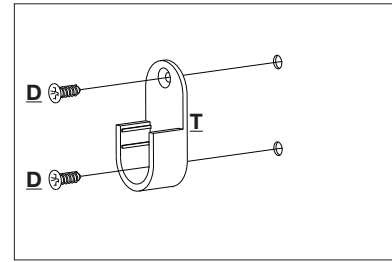
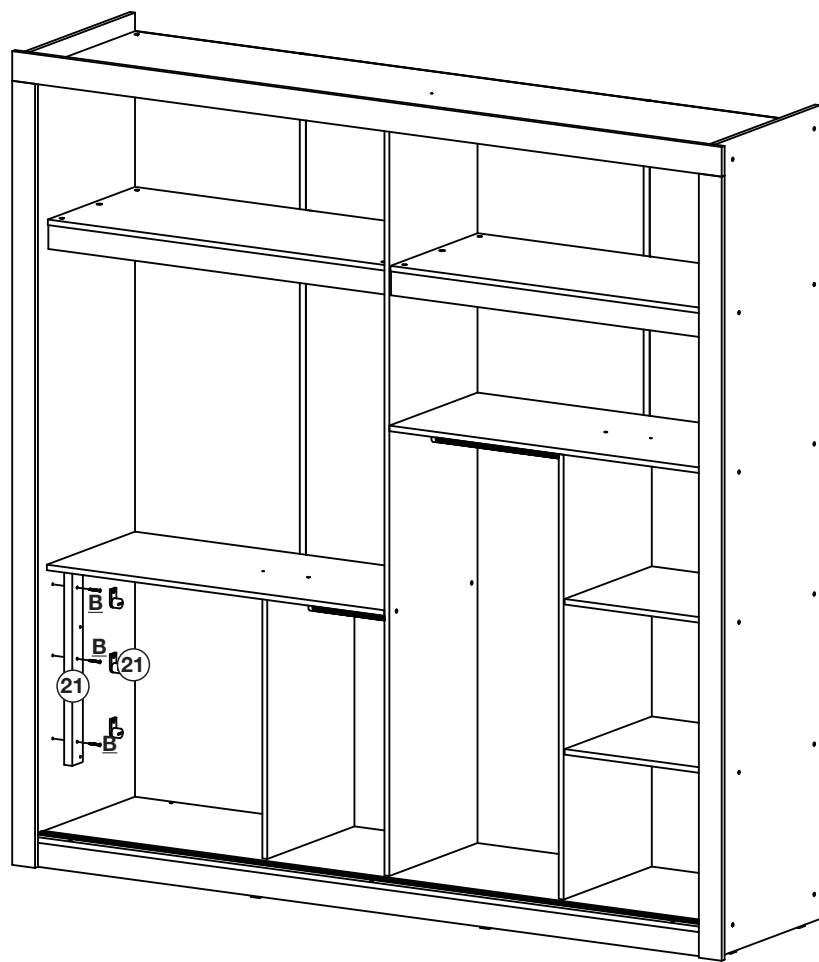

Guia superior da porta de correr.

Guía superior de la puerta corredera.

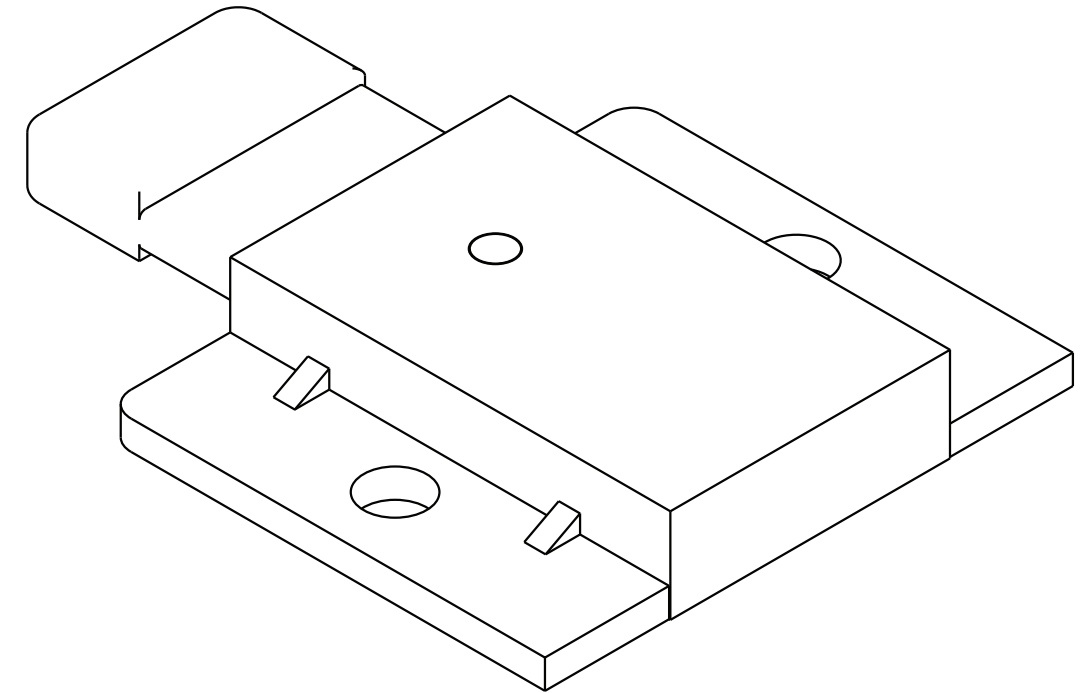

Rodízio inferior da porta de correr.

Rotación inferior de la puerta corredera.

Após regular a porta fixar dois parafuso do kit.

Después de configurar la puerta fijó dos Juego de tornillos.

Para regulagem da porta.

Para la regulación de la puerta.

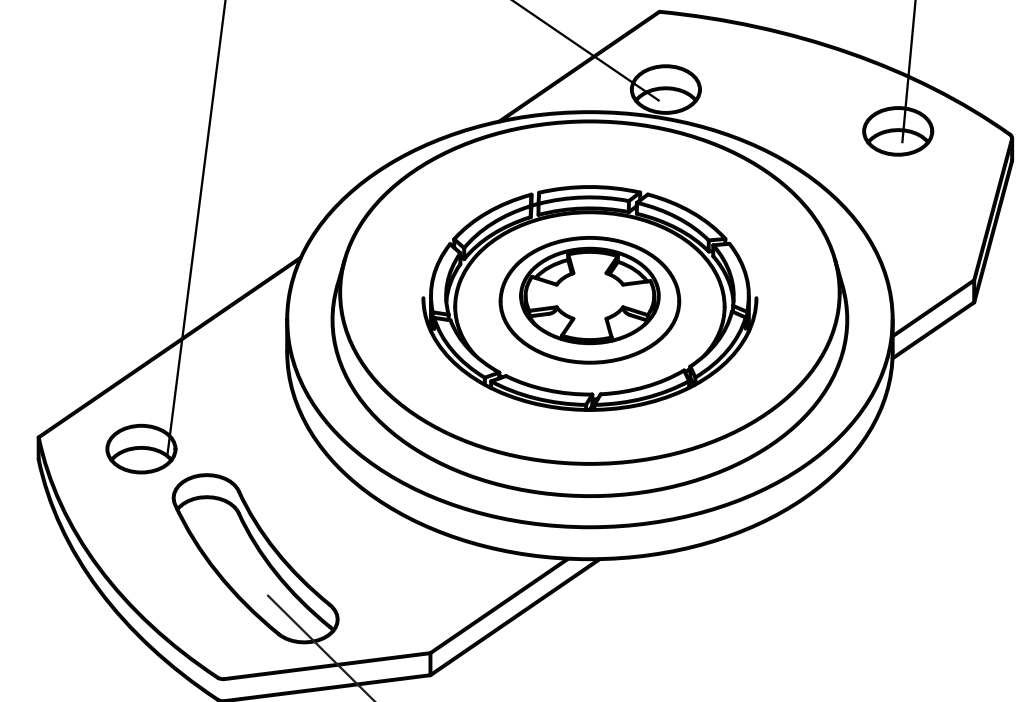

Para regulagem da porta.

Para la regulación de la puerta.

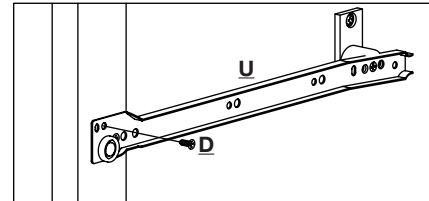
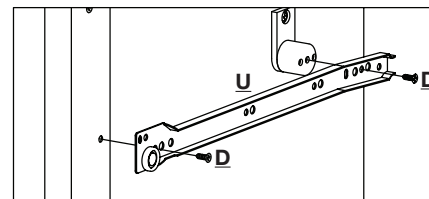
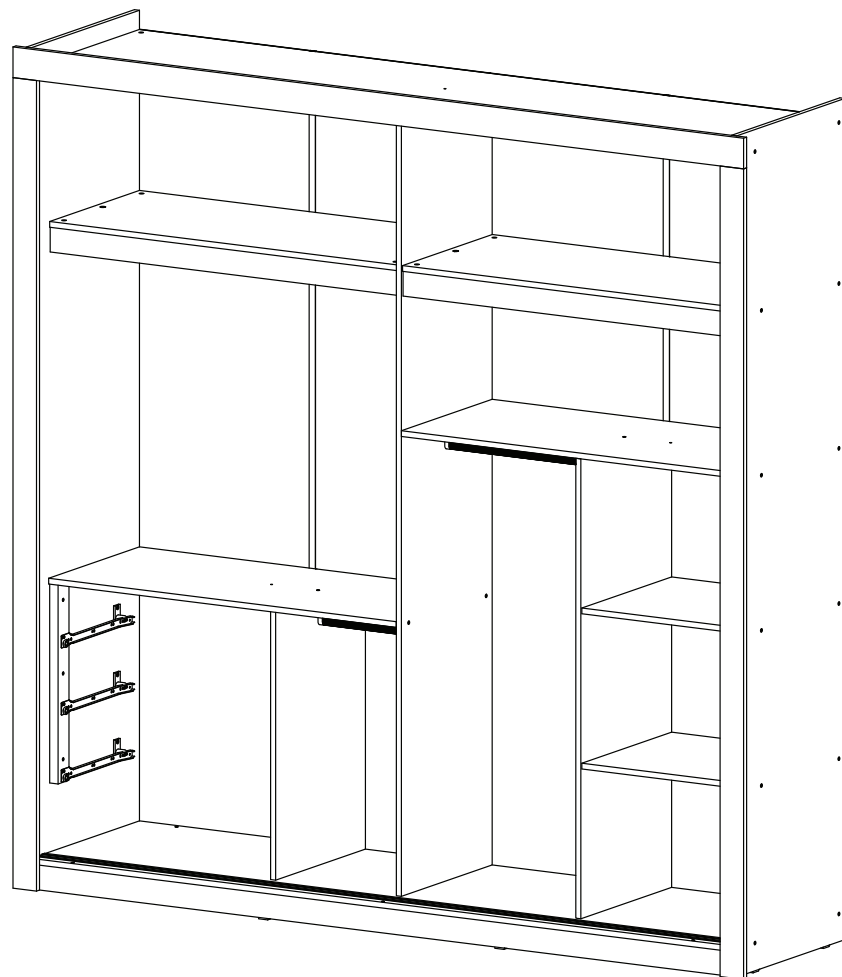

Fixação da corrediça (U) nas ripas laterais (21).

Cierre de cremallera (U) las tiras laterales (21).

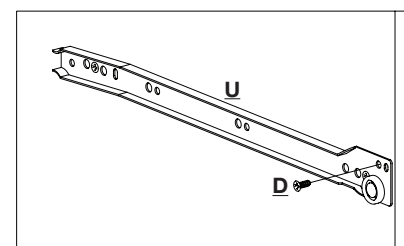
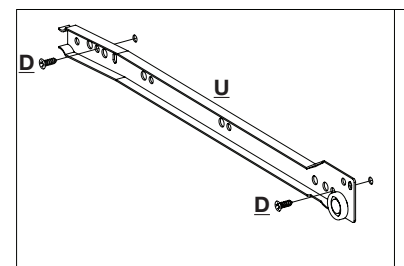

Fixação da corrediça (U) na divisão do gaveteiro (06).

Cierre de cremallera (U) la división de cajones (06).