

# Bar

## Star

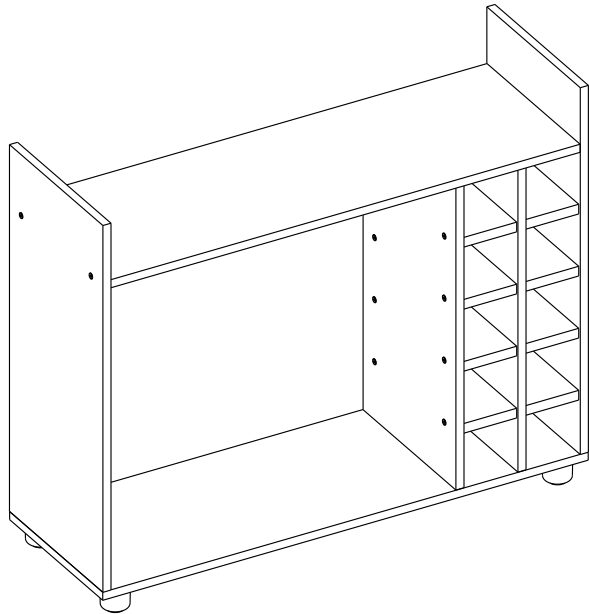

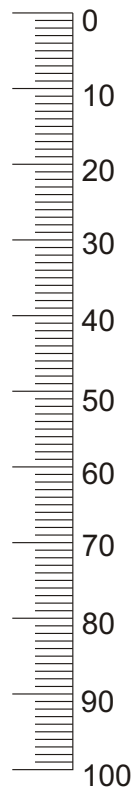





Produto finalizado

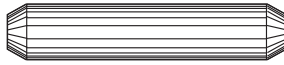
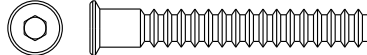

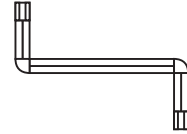
Medidas em mm  
Escala 1:1

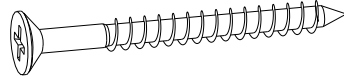
### Componentes

|   |  |
|---|--|
|  | A-Cavilha de marfim 6x40 - X12               |
|  | B- Parafuso Soberbo 5,0X50 SEX/Interna - X28 |
|  | C- Sapata Plastica - X05                     |
|  | D -Chave Zetta Allen 3 mm - X01              |
|  | E- Sachet Cola - X01                         |
|  | F- Parafuso chato 4,0x45- X05                |
|  | G- Tapa Furo 5mm -X 12                       |

### ATENÇÃO

- 1- Ler e observar atentamente toda a instrução antes de iniciar a montagem.
- 2- A montagem do produto deverá ser feita em uma superfície limpa e plana. Aconselhamos utilizar a embalagem para forrar o chão a fim de não danificar o produto.
- 3- Os parafusos devem ser apertados periodicamente.
- 4- Evitar contato com objetos cortantes.
- 5- Evitar batidas.

### LIMPEZA

- 1- Pano levemente umedecido com água, seguido de pano seco.
- 2- Não utilizar produtos químicos ou abrasivos.

"As partes protegidas da incidência de luz estão sujeitas a alterações de tonalidade diferentemente das partes expostas; recomendamos o uso freqüente para diminuir esta probabilidade.

### Pessoas Necessárias para Montagem



### Ferramentas Necessárias (Não Fornecidas)

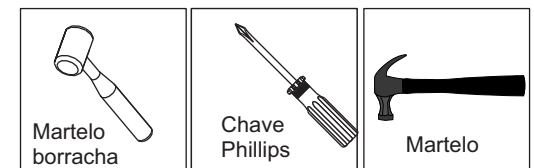

# Produto Explodido

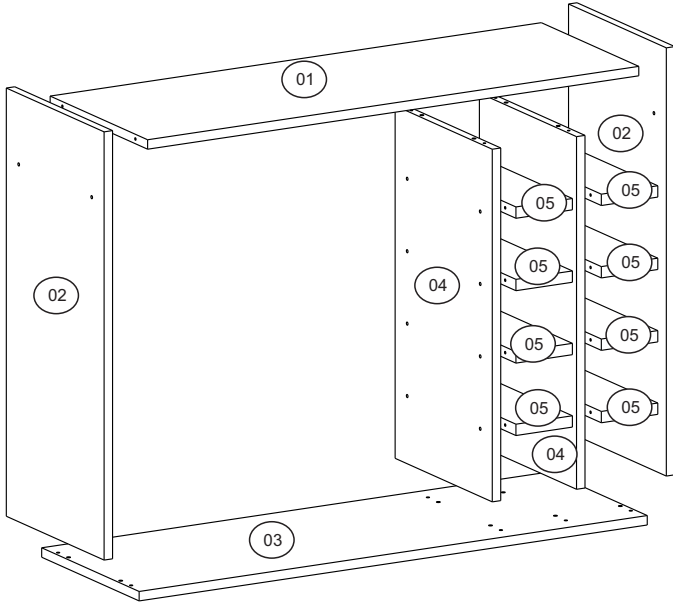

## 1º passo

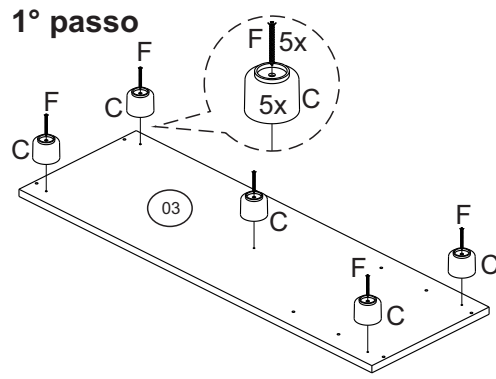

## 2º passo

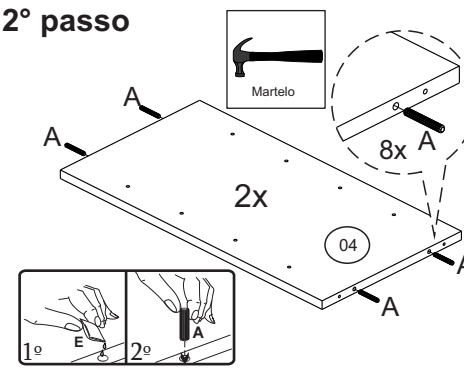

## 3º passo

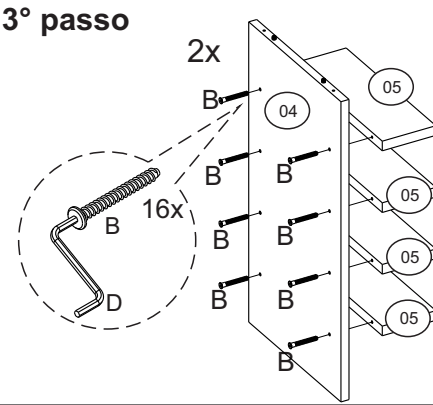

## 4º passo

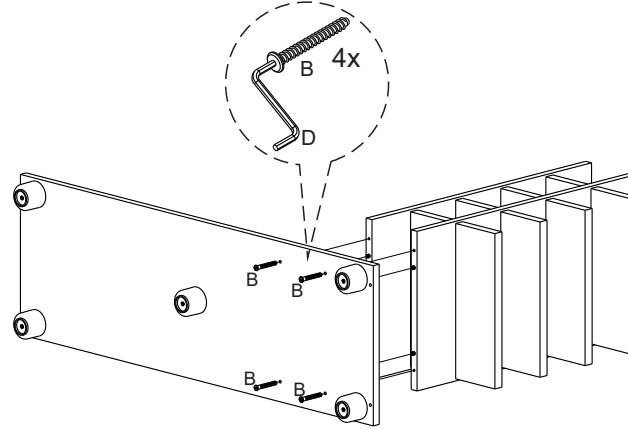

## 5º passo

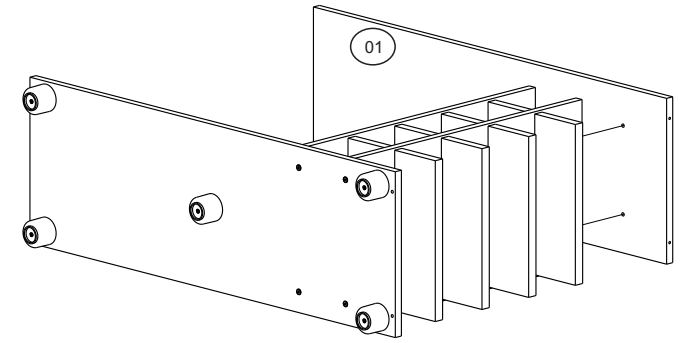

## 6º passo

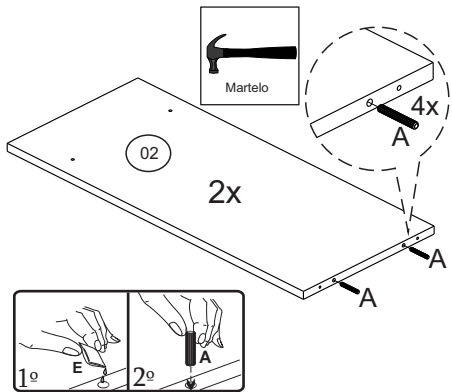

## 7º passo

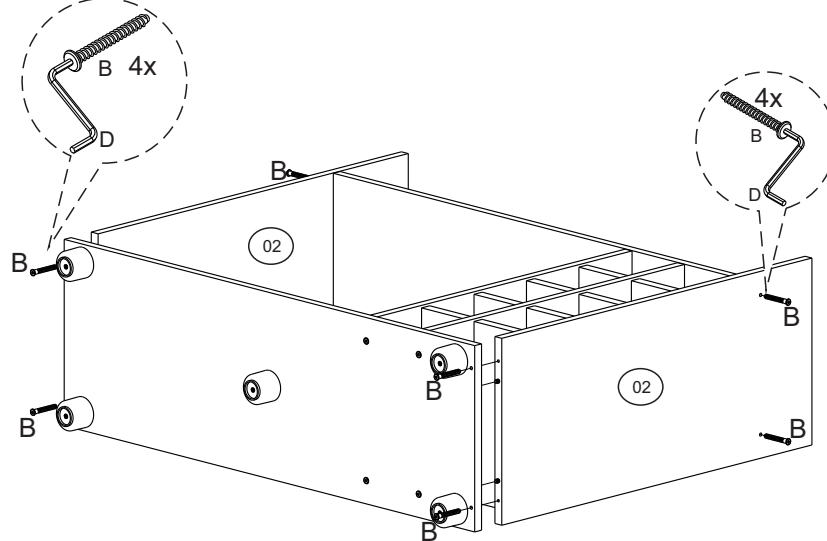

## 8º passo

