

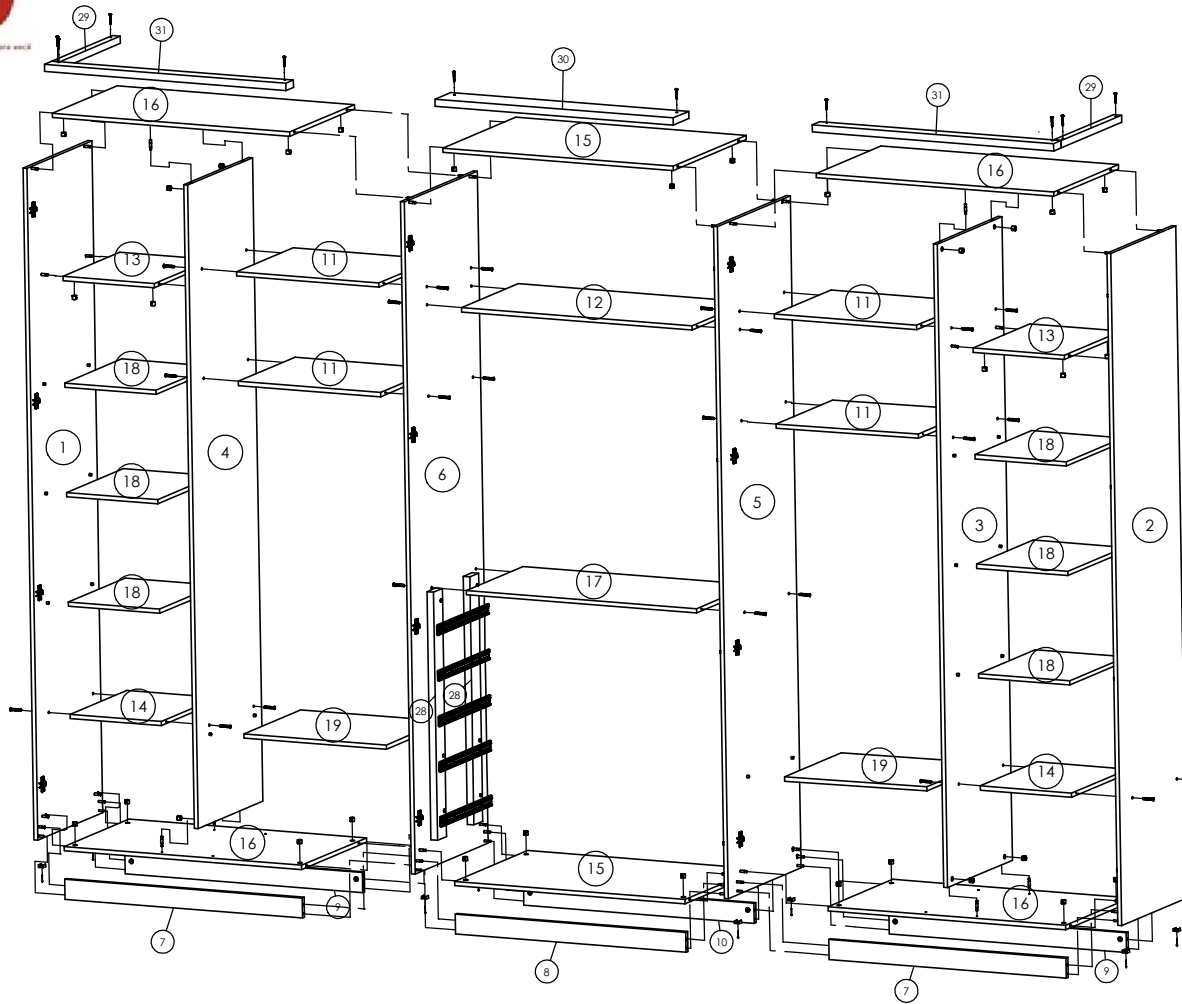

Roupeiro Unique 6 Portas / Wardrobe Unique 6 Doors / Ropero Unique 6 Puertas

Faça um espaço mínimo de 60cm



Roupeiro Unique

22-janeiro-2016

Peça Pieza	Cod.	Descrição	Description	Descripción	Qtde Qty Cant	Compr Length Largo	Larg. Width Ancho	Esp. Thickness Espesor
1	P13367	Lateral Esq.	Left Side Panel	Lateral Izquierda	1	2357	514	15
2	P13368	Lateral Dir.	Right Side Panel	Lateral Derecha	1	2357	514	15
3	P13336	Divisão Direita	Right Division	Division Derecha	1	2257	514	15
4	P13324	Divisão Esquerda	Left Division	Division Izquierda	1	2257	514	15
5	P13366	Divisão Central Direita	Central division right	División Central a la derecha	1	2357	578	15
6	P13365	Divisão Central Esquerda	Central division left	División Central izquierda	1	2357	578	15
7	P13369	Frente Pé	Frontal Botton Frame	Zocalo Frontal	2	906	70	15
8	P13370	Frente Pé	Frontal Botton Frame	Zocalo Frontal	1	879	70	15
9	P13330	Traseiro Pé	Back Botton Frame	Zocalo Traseiro	2	906	70	15
10	P13332	Traseiro Pé	Back Botton Frame	Zocalo Traseiro	1	879	70	15
11	P13310	Tampo	Top	Tapa	4	543	450	15
12	P13308	Tampo	Top	Tapa	1	879	450	15
13	P13312	Tampo	Top	Tapa	2	348	450	15
14	P13537	Tampo c/ Soberbão	Top c/ Soberbão	Top c/ Soberbão	2	348	450	15
15	P13307	Tampo Inferior / Superior	Inf/Sup Top	Tapa Inf/Sup	2	879	578	15
16	P13306	Tampo Superior / Inferior	Inf/Sup Top	Tapa Inf/Sup	4	906	514	15
17	P13309	Tampo Superior Gaveta (1 lado sem pintura)	Drawer Superior Top	Tapa superior del cajón	1	879	450	15
18	P13313	Prateleira	Shelf	Repisa	6	348	450	15
19	P13311	Prateleira	Shelf	Repisa	2	543	450	15
20	P13460	Prateleira Sapateira	Shoe shelf	Estante del zapato	1	804	426	15
21	P13338	Fundo	Background	Fondo	2	2297	558	2,5
22	P13339	Fundo Central	Background	Fondo	2	2297	445	2,5
23	P13337	Fundo Lateral	Background	Fondo	2	2297	363	2,5
24	P11444	Traseiro Gaveta	Drawer Back	Traseiro Cajón	4	805,5	88	15
25	P11445	Fundo Gaveta	Drawer Back	Fondo Cajón	4	805,5	406	2,5
26	P10604	Lateral Gaveta	Drawer Side	Lateral Cajón	8	385	88	15
27	P11443	Frente Gaveta	Front drawer	Frente de cajón	4	822,5	135	15
28	P13319	Distanciador	Spacer	Spacer	4	870	70	25
29	P13361	Moldura Sup. Lateral	Frame Sup. Side	Frame Sup. Side	2	479	30	25
30	P13364	Moldura Sup. Central	Frame Sup. Central	Frame Sup. Central	1	909	124	25
31	P13363	Moldura Sup.	Frame Sup.	Frame Sup.	2	921	60	25
32	P13461	Frente Sapateira	Crab Front	Delante de cangrejo	1	823	68	15

4407 - Roupeiro Unique 6P Carvalho Sensitive C| Champagne

33	P13359	Porta Carvalho	Door	Puerta	2	2307	545	15
34	P13357	Porta Carvalho	Door	Puerta	2	2307	443	15
35	33256	Porta de Vidro Carvalho	Glass Door	Puerta de vidrio	2	2307	355	15



**Atenção com a cor do acabamento!
Em caso de assistência solicitar o código de acordo com a cor da peça**

Medidas em mm



Cod.	Qt.	Image	Description
A	18		Parafuso 3,5x12 CP (P/ Suporte Cabideiro) 25671
B	20		Paraf. Corrediza 6x12 22396
C	50		Parafuso Minifix 25679
D	62		Tambor Minifix 22388
E	45		Cavilha 6x30 24603
F	16		Cantoneira Plástica 27097
G	180		Prego 10x10 CC 20179
H	96		Parafuso 4X14 CC 25673
I	1		Adesivo Logotipo THB 31363
J	24		Calço p/ Dobradiza 23273
K	32		Parafuso Soberbão 7x40 PH 10 25691
L	16		Dobradiza Baixa 23271
M	32		Tampa Soberbão 26558 - Champ 33290 - Cavalho 23272
N	8		Dobradiza Alta 24099
O	60		Presilha Fundo 24099
P	8		Sapata Plástica 33257 - Carvalho
Q	6		Suporte Cabideiro 20039
R	32		Suporte Prateleira 27098
S	2		Parafuso 3,5x20 CF 33416 (2und embaladas c/ Puxador Palio)
T	8		Parafuso 3,5x25 CF 33415 (8und embaladas c/ Puxador Bellano)
U	6		Minifix Haste Dupla 25675
V	4		Puxador Bellano 800mm 33231
W	2		Puxador Ponto Palio 32413
X	8		Tapa Furo 5mm 29900 - Champ
Y	2		Cabideiro Oblongo 536 33188
Z	1		Cabideiro Oblongo 872 31252
AA	5		Corrediza Telescópica Macho Esq. 31929
AB	5		Corrediza Telescópica Macho Dir. 31929
AC	5		Corrediza Telescópica Fêmea Esq. 31929
AD	5		Corrediza Telescópica Fêmea Dir. 21610
AE	2		Sachê de Cola 25676
AF	22		Parafuso 3,5x35 CF 25762
AG	70		Parafuso 3,5x14 CP 25736
AH	8		Suporte Triangular 30094
AI	1		Divisor de Gaveta 33372
AJ	1		Perfil H 2297 33189
AK	56		Tampa Tambor 25682 - Champ

Roupeiro Unique 6 Portas / Wardrobe Unique 6 Doors / Ropero Unique 6 Puertas

1º Passo / Step / Paso

Na fixação dos Tamos, (11), (13), (14) e (16) usar Parafuso **K**, Minifix **C** e Minifix Aste Dupla **U** / In setting the types, (11), (13), (14) and (16) using screw **K**, **C** and Minifix Minifix Aste Doubl **U** / Al fijar los tipos, (11), (13), (14) y (16) con el tornillo **K**, **C** y Minifix Minifix Aste Doble **U**.

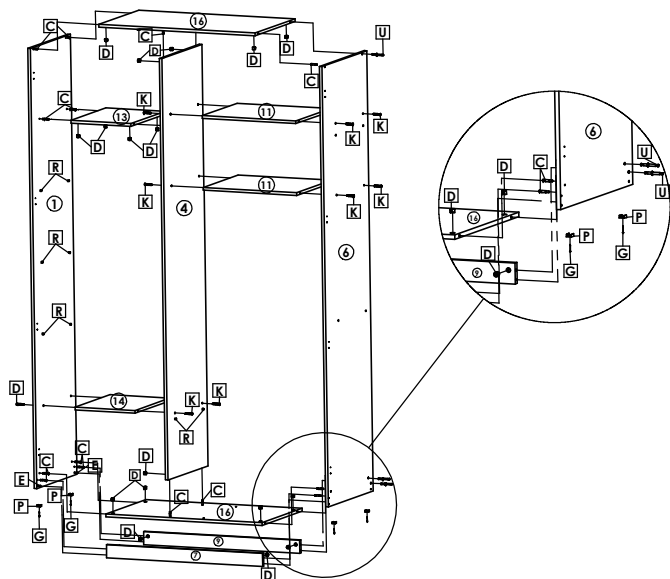

2º Passo / Step / Paso

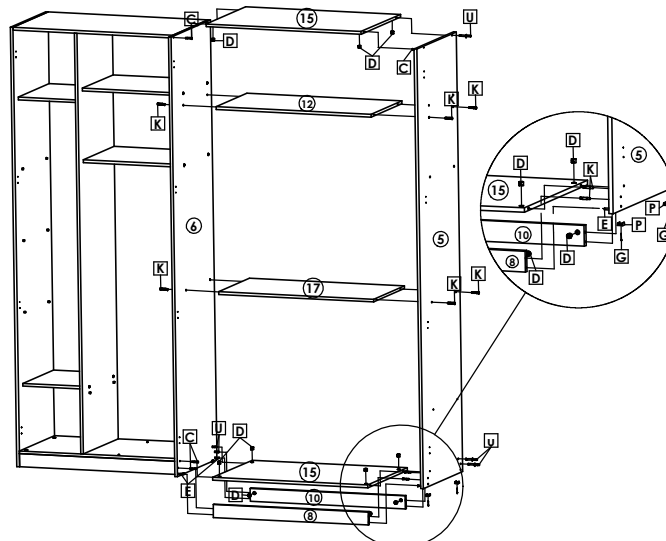

3º Passo / Step / Paso

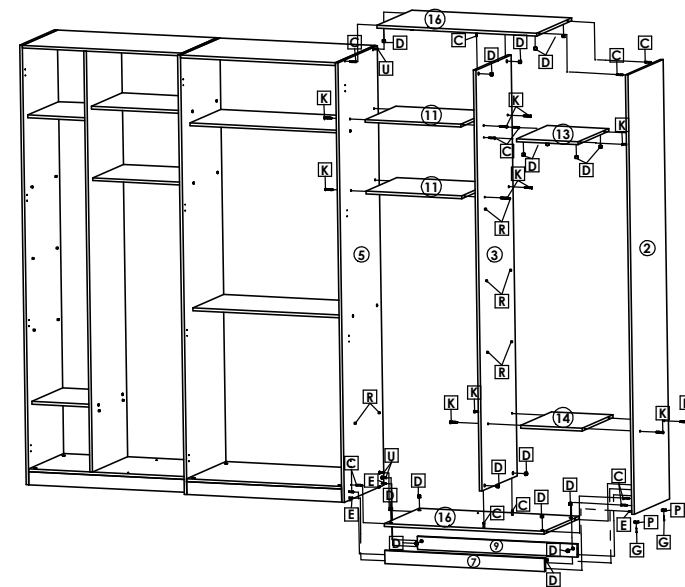

4º Passo / Step / Paso

Fixar os Fundos (21), (22) e (23) com prego **G**, Presilha **Q** e Perfil H **AJ** /
Fix the Funds (21), (22) and (23) with nail Clip **G** and Profile H **AJ** /
Fijar los Fondos (21), (22) y (23) con el clavo **G**, Clip **Q** y Perfil H **AJ**.

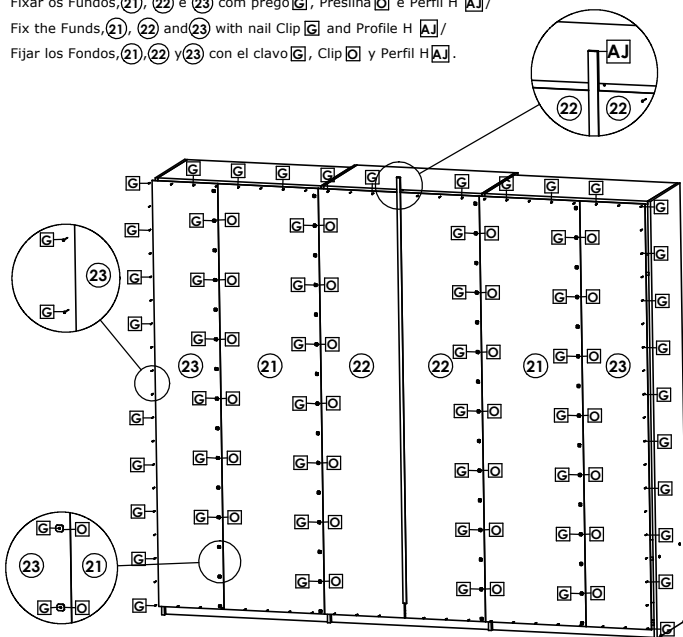

5º Passo / Step / Paso

Fixar as Molduras no Topo das Laterais 1 e 2 /
Moldings fixar as Topo not give Laterais 1 e 2 /
Fixar como Molduras sin Topo das Laterais 1 e 2.

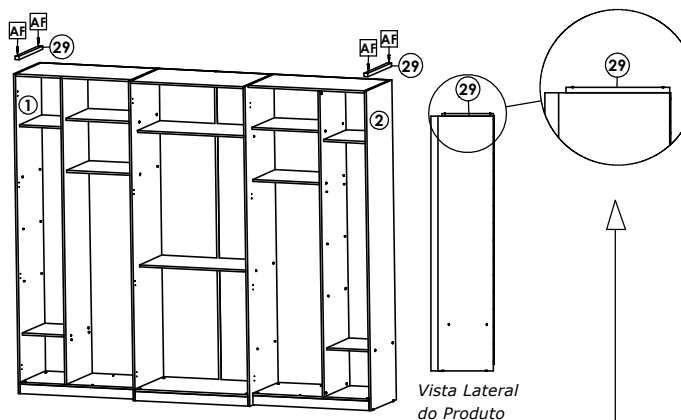

Fixação da Moldura Lateral (29) /
Fixing Frame Side (29) /
Fixação da Moldura lateral (29).

A Moldura Lateral (29) deve ser alinhada com a parte traseira das Laterais 1 e 2 /
A side trim (29) deve be alinhada com traseira part to give Laterais 1 e 2 /
Un Moldura lateral (29) deve alinhada Ser com a parte traseira das Laterais 1 e 2.

6º Passo / Step / Paso

Alinhar as Molduras Frontais (31) com as Molduras Laterais (29) /
Alinhar as (31) com as trim moldings Frontais Laterais (29) /
Alinhar como Molduras Frontais (31) com Molduras Laterais (29).

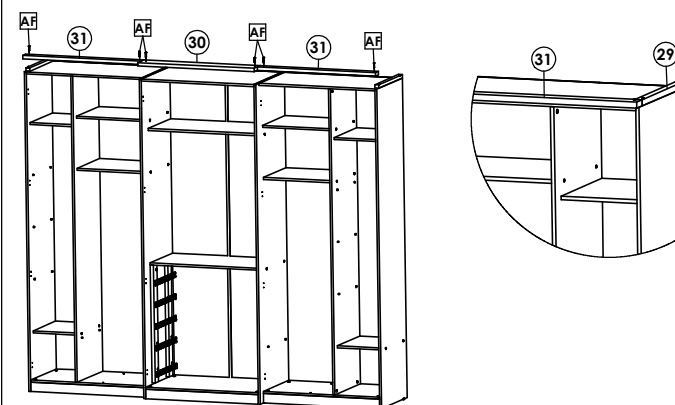

Roupeiro Unique 6 Portas / Wardrobe Unique 6 Doors / Ropero Unique 6 Puertas

7º Passo / Step / Paso

Montagem do Distânciador/Mounting spacer/Montaje espaciador.



Alinhar o Distânciador (28) ao Tampo (17) e fazer a fixação com o Parafuso AF/
Align the spacer (28) to (17) Surface and make fixing with screw AF/
Alinee el espaciador del (28) al (17) de superficie y dar a la fijación con tornillo de AF.

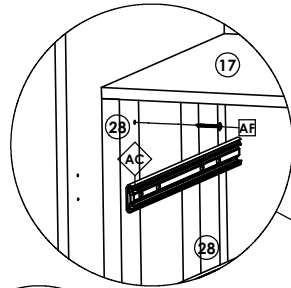
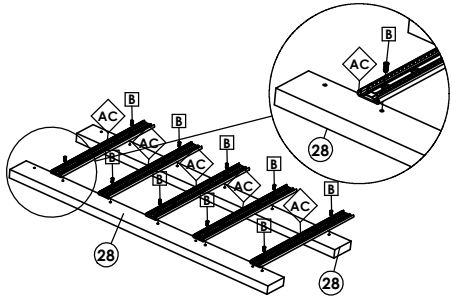

Montagem da Gaveta/Mounting Drawer /Montaje del cajón.

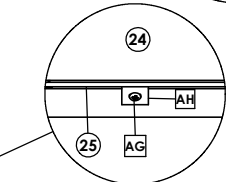
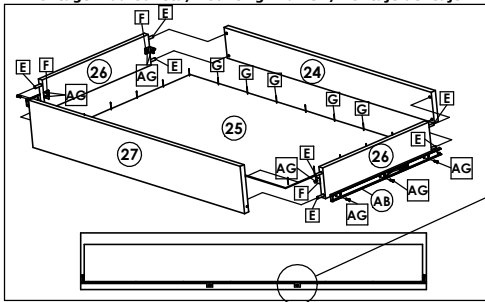

Segurança do Fundo Gaveta (25)/
Security Drawer Fund(25)/
Fondo de cajón de Seguridad (25).

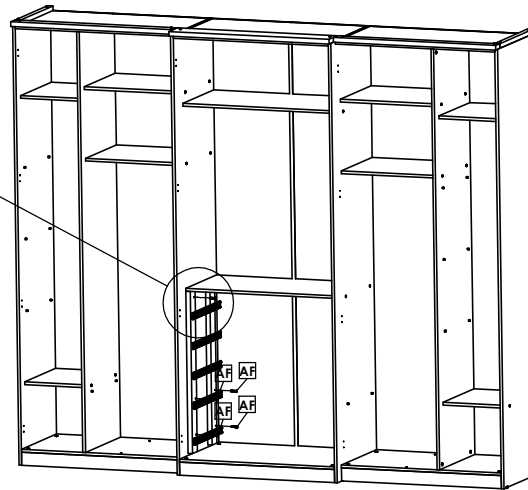

8º Passo / Step / Paso

Inserindo Prateleiras, Gavetas e Cabideiros/
Inserting shelves, drawers and Coat Racks/
Inserción de estantes, cajones y Bastidores Coat.

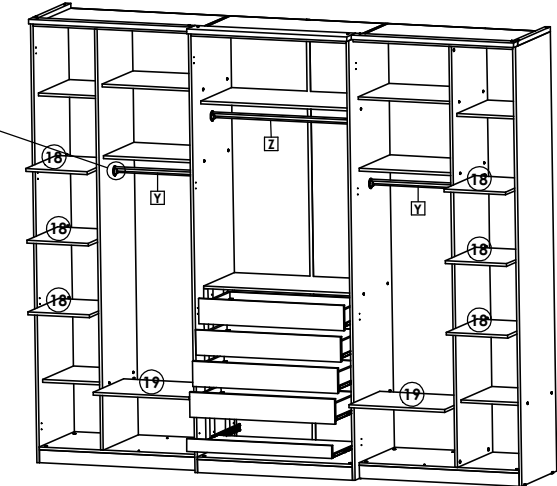
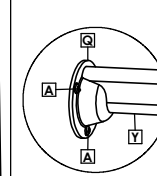

9º Passo / Step / Paso

Peso Suportado / Weight supported / peso que soporta

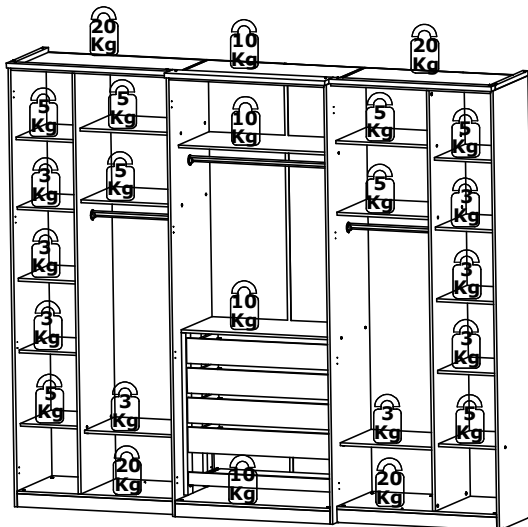

Peso Suportado por Gaveta/
Supported by weight Drawer/
Con el apoyo de cajón de peso.



Montagem Portas Unique / Unique Doors / Puertas Unique

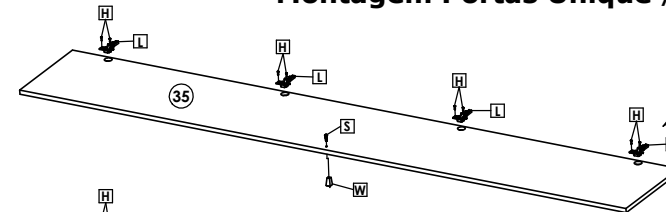

Porta de vidro/ Windowpane Door/ Puerta de vidrio.

Usar Dobradiças L Baixa na Porta de Vidro(35)/
Use hinges L Low in Glass Door (35)/
Uso bisagras L Bajo en la puerta de cristal (35).

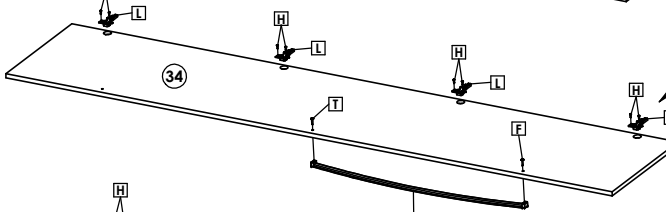

Porta Central/ Central door/ Central de la puerta.

Usar Dobradiças L Baixa na Porta Central(34)/
Use hinges L Low in Central Port (34)/
Uso bisagras L Bajo en Puerto Central (34).

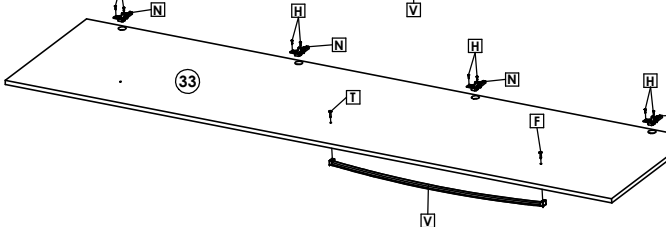

Porta Maior/ Increased port/ Aumento de puerto.

Usar Dobradiças N Alta na Porta Maior (33)/
Use hinges N High in the Greater Port (33)/
Uso bisagras N de alta en el Gran Puerto (33).



Roupeiro Unique 6 Portas / Wardrobe Unique 6 Doors / Ropero Unique 6 Puertas

10º Passo / Step / Paso



ATENÇÃO
HEADS UP
PRECAUCIÓN

As Portas (34) e (35) devem ser fixadas com Dobradiças **L** e Calço **J** /
Ports (34) and (35) must be secured with Hinges **L** and chock **J** /
Puertos (34) y (35) deben asegurarse con bisagras **L** y bloquee **J**.

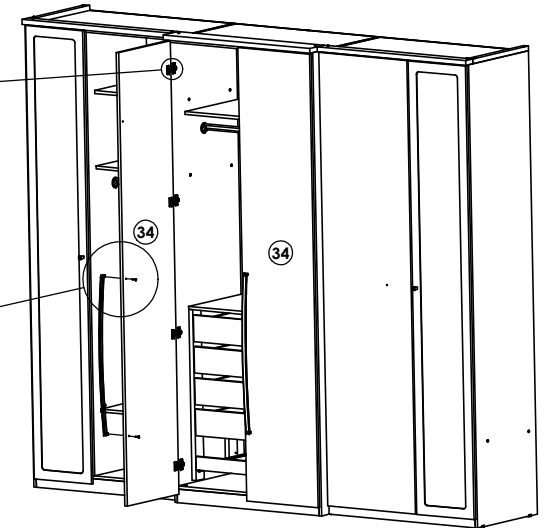
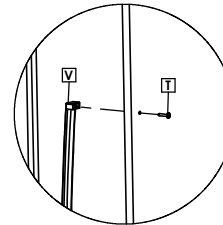
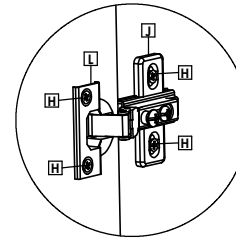
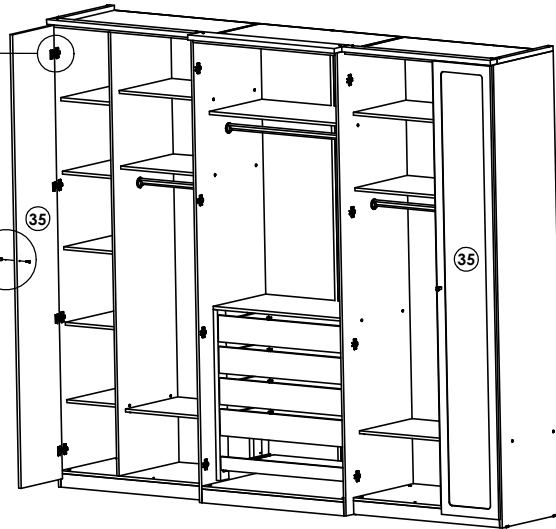
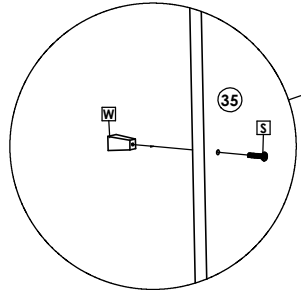
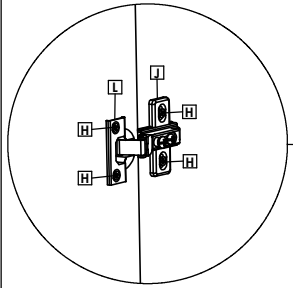

12º Passo / Step / Paso



ATENÇÃO
HEADS UP
PRECAUCIÓN

A Portas (33) deve ser fixada com Dobradiças Altas **N** e Calço **J** /
The doors (33) must be secured with hinges High **N** and chock **J** /
Las puertas (33) deben asegurarse con bisagras de alta **N** y hasta los topes **J**.

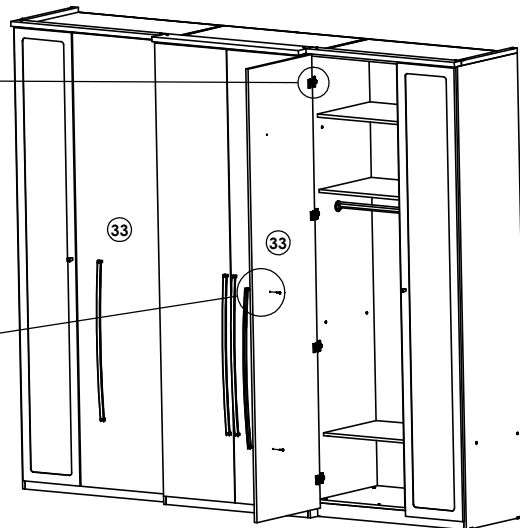
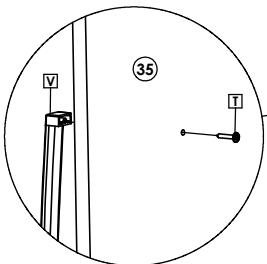
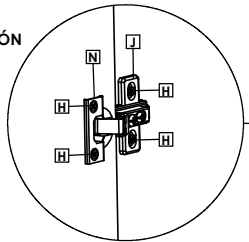

Unique 6P

