

ACESSORIOS / HARDWARE / ACESSÓRIOS

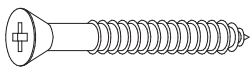

A | parafuso 4,0 x 40 | 20 un

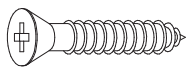

B | parafuso 4,0 x 25 | 02 un



C | parafuso 4,0 x 14 | 24 un



D | prego 11 x 11 | 30 un



E | Dobradiças | 02 un



F | Suporte | 04 un

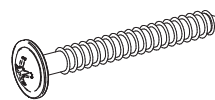

G | parafuso 6,0 x 50 | 04 un



H | Bucha 8mm | 04 un

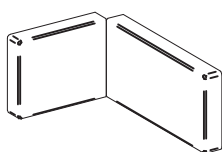

I | capa Suporte | 04 un

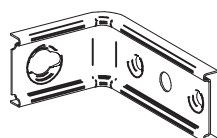

J | Suporte Parede | 04 un



K | 20 un.

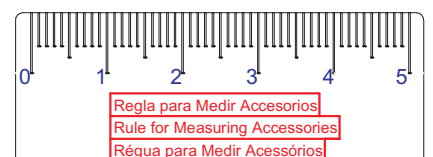

FERRAMIENTAS
 HARDWARE
 FERRAMENTAS

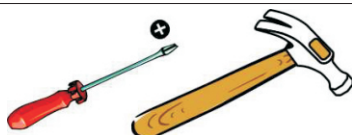

PERSONAS NECESSARIAS PARA EL MONTAJE
 PEOPLE REQUIRED FOR ASSEMBLY
 PESSOAS NECESSÁRIAS PARA A MONTAGEM



Consejos de Conservación

- No debe utilizarse en la limpieza, abrasivos como lana de acero, alcohol, vinagre, limón, o productos corrosivos que puedan rayar o quitar la película protectora en los muebles.
- Cuando la limpieza de muebles en general, napa y formica, deben utilizarse un paño ligeramente humedecido y jabón suave.
- Para mover el móvil, es importante que este se eleve desde el suelo, debido a que el arrastre puede causar daño estructural.
- No deje a su móvil en exposición a la intemperie.

Conservation Tips

- Do not use abrasive products to clean such as steel wool, alcohol, vinegar, lemon, scouring powder, or corrosive products which can scratch or peel off the protective film of the furniture.
- The best way to clean your furniture is to use a slightly moistened cloth with a mild soap.
- To move the furniture assembled, it is important that it is lifted off the ground, because the drag it can cause structural damage.
- Do not leave your furniture in weather exposure.

Dicas de Conservação

- Não utilizar na limpeza produtos abrasivos tais como: palha de aço, álcool, vinagre, limão, saponáceo, ou produtos corrosivos que possam riscar ou descolar a película protetora dos móveis.
- Na limpeza de móveis em geral, napa e fórmicas, deve ser utilizado um pano levemente umedecido e sabão neutro.
- Para a movimentação do móvel, é importante que este seja levantado do chão, pois ao arrastá-lo pode causar avarias estruturais.
- Não deixe o móvel em exposição a intempéries.

Certificado de Garantia

A garantia dos produtos fabricados pela Carraro, abrange eventuais defeitos/vícios de fabricação, no prazo estabelecido pelo Código de Defesa do Consumidor, em seu artigo 26,II, o qual prevê a garantia legal de 90 (noventa) dias.

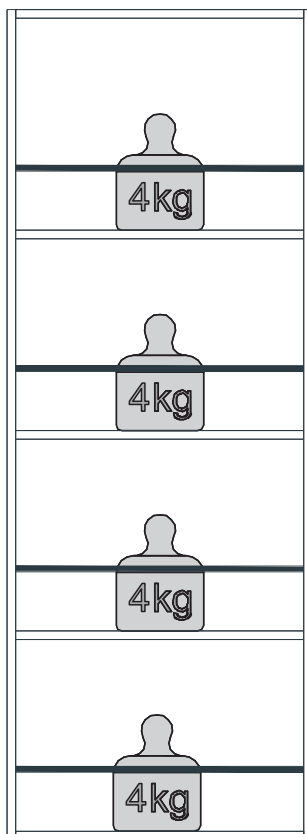

Peso por estante

Por favor, preste atención a los pesos máximos admitidos por cada compartimento del producto. Tenga cuidado de no exceder estos pesos, con el fin de garantizar la calidad y durabilidad del producto.

Es importante recordar que los pesos muestran en caso de ser distribuida en toda el área de la plataforma.

Weight per shelf

Please pay attention to the maximum weights supported by each compartment product. Be careful not to exceed these weights, in order to ensure the quality and durability of the product. It is important to remember also that the weights shown should be distributed throughout the area of the shelf.

Peso por Prateleira

Ao lado são demonstrados os pesos máximos suportados por cada compartimento do produto. Cuide para não exceder esses pesos, afim de garantir a qualidade e a durabilidade do mesmo. É importante lembrar também, que os pesos mostrados devem ser DISTRIBUÍDOS ao longo de toda a área da peça.

Lista de piezas
Parts List
Lista de peças

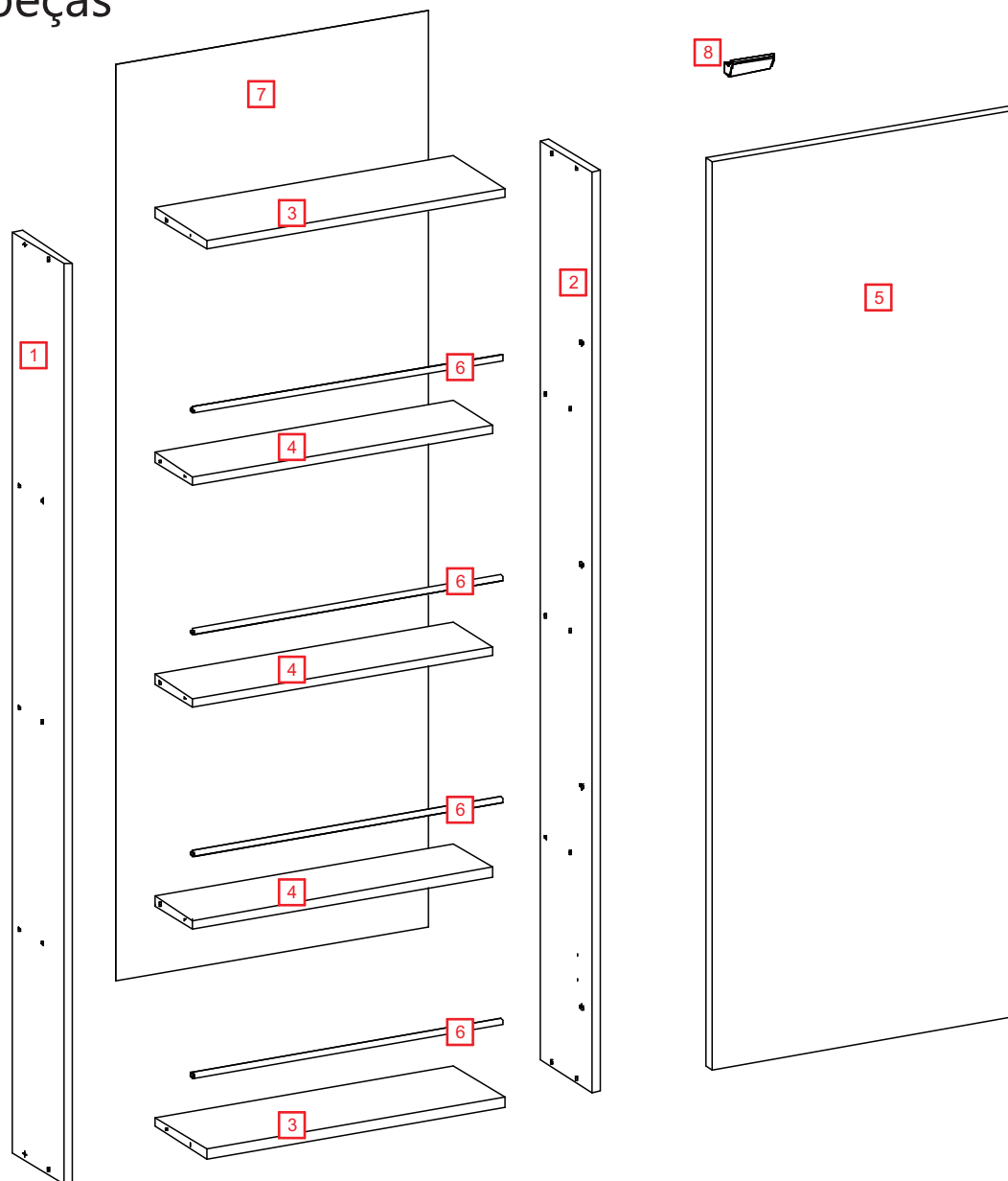

#	Qde	Español	English	Português	Dimensões
1	1	Lateral Derecha	Right Side	Lateral Direita	1196 x 135 x 12
2	1	Lateral Izquierda	Left Side	Lateral Esquerda	1196 x 135 x 12
3	2	Base-Tapa	Base-Top	Base Chapéu	416 x 135 x 12
4	3	Estante	Shelf	Prateleira	416 x 100 x 12
5	1	Puerta	Door	Porta	1185 x 424 x 15
6	4	Tubo de Plastico	Plastic Tube	Tubo Plástico	Ø8 x 430
7	1	Costado	Back Panel	Costa	1190 x 435 x 2,5
8	1	Tirador	Handle	Puxador	

01

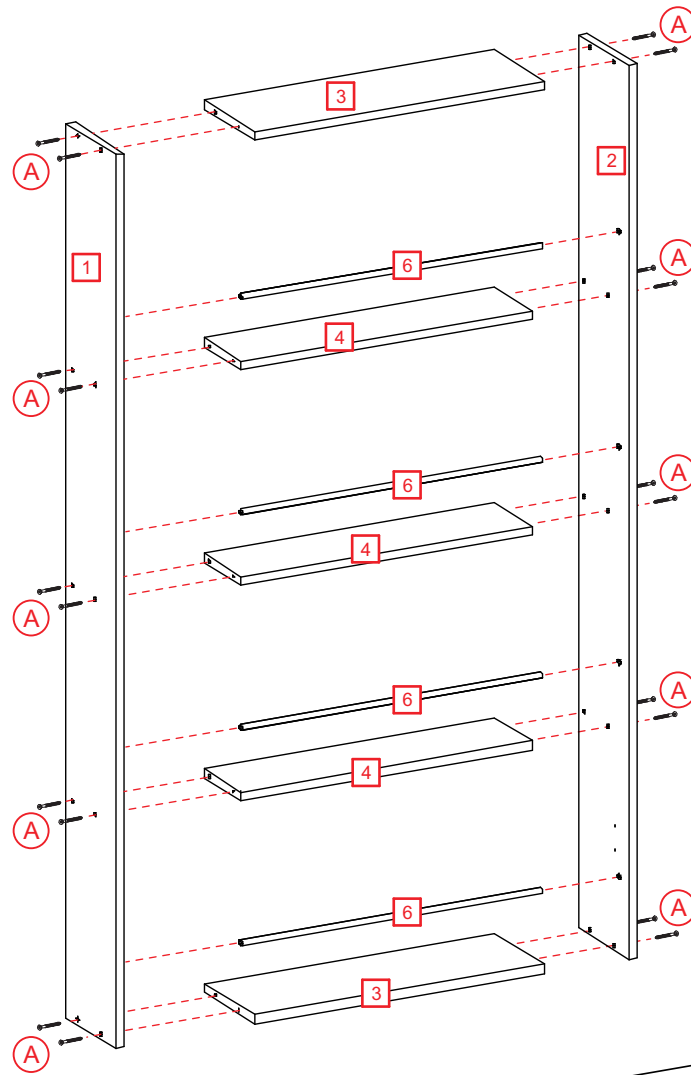

Fijar fondo con clavos
cada 150mm,
en la línea de puntos.

Fasten back panel with nails
every 150mm,
where indicated by the dotted line.

Fixar a costa com pregos
a cada 150mm,
onde indicado pela linha vermelha.

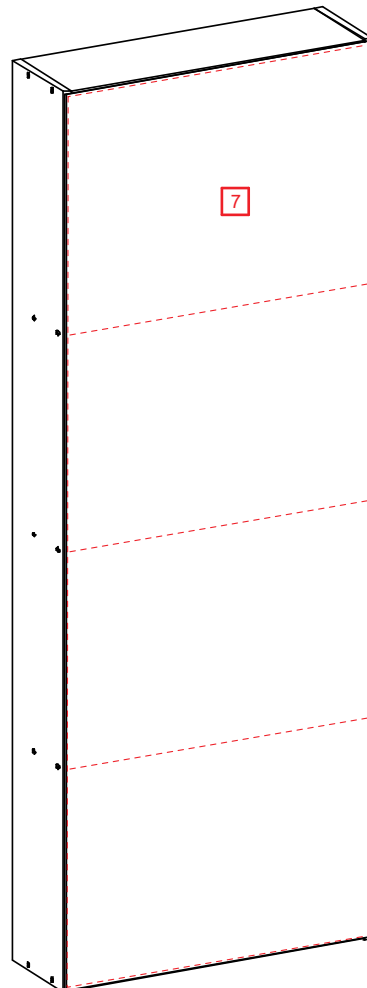
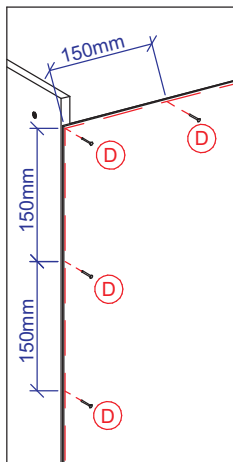

05

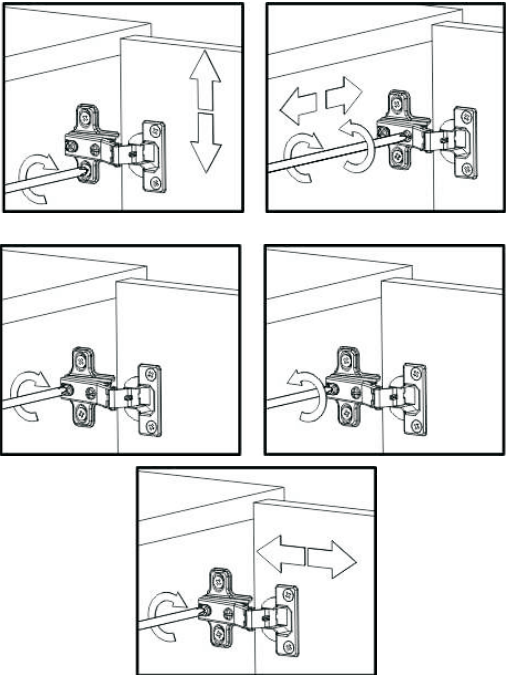
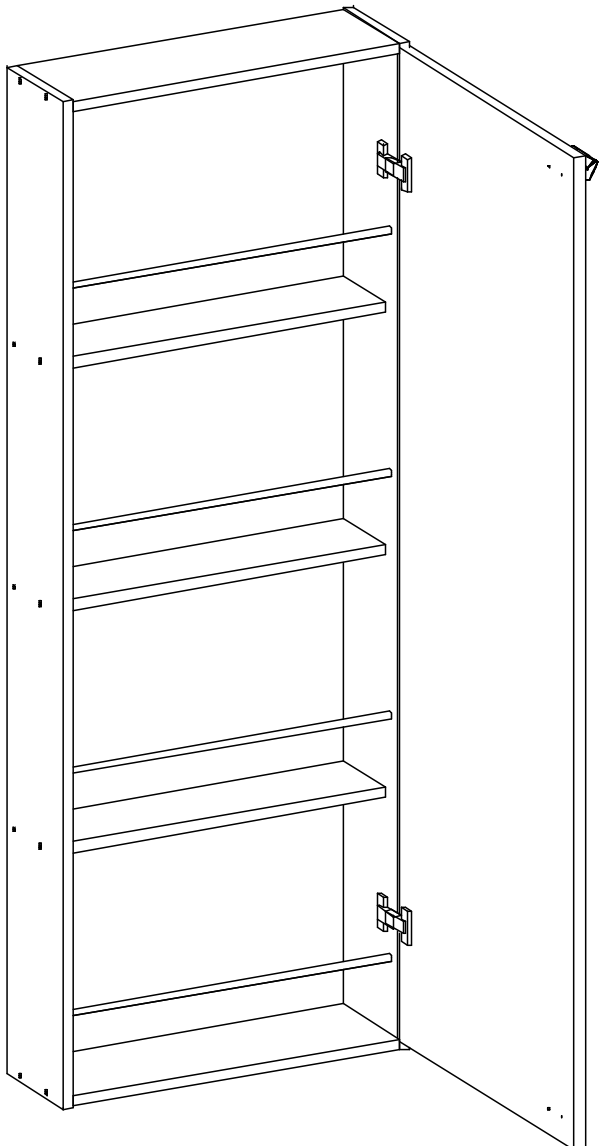
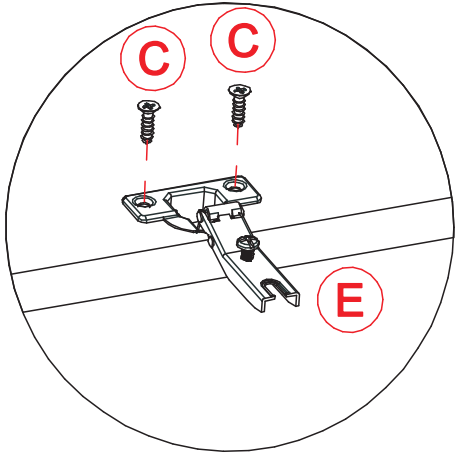
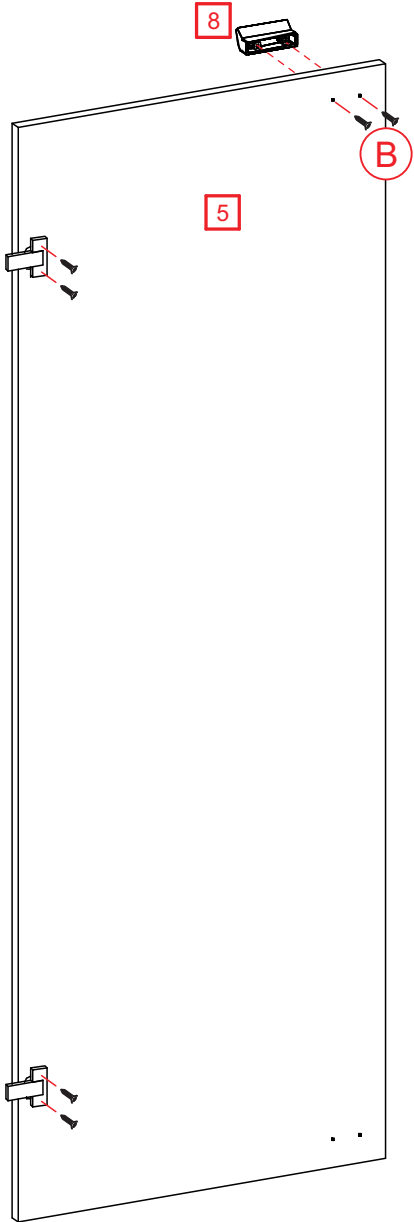

Fixação na parede.

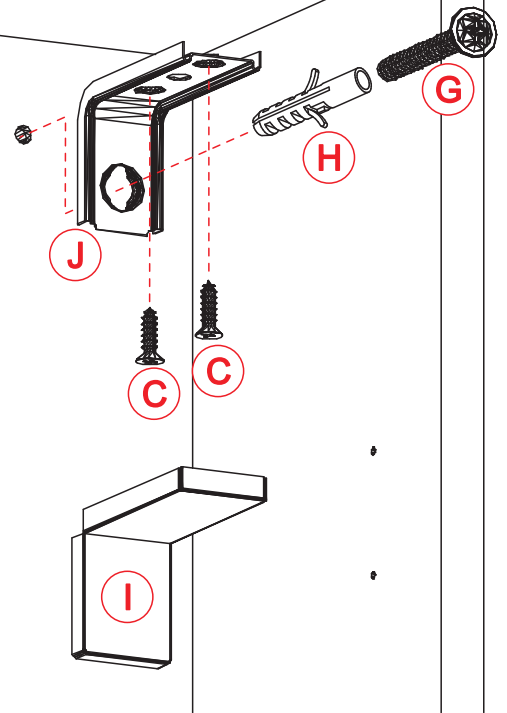
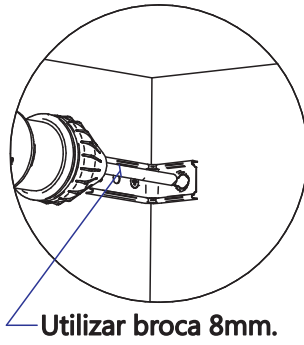
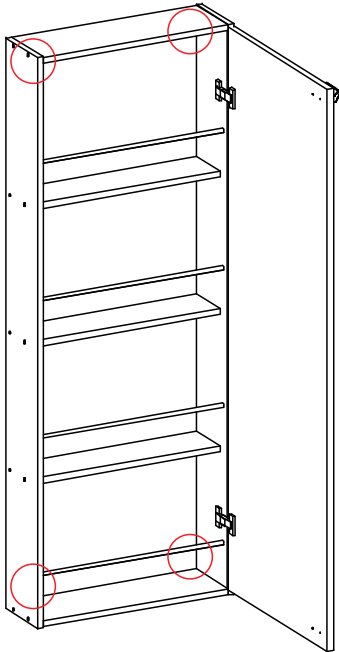

Fixação em roupeiro.

