

Roupeiro Advance

Peça Pieza	Cod.	Descrição	Description	Descripción	Qtde Qty Cant	Compr Lenght Largo	Larg. Width Ancho	Esp. Thickness Espesor
1	P13340	Lateral Esquerda	Left Side Panel	Lateral Izquierda	1	2252	600	15
2	P13341	Lateral Direita	Right Side	Lateral Derecho	1	2252	600	15
3	P13345	Tampo Inferior	Inferior Top	Tapa Inferior	1	2697	600	15
4	P13344	Tampos Superior	Superior Top	Tapa Superior	1	2667	600	15
5	P13550	Tampo Intermediário	Intermediate Top	Tapa Intermediaria	4	879	450	15
6	P13342	Divisão Esquerda	Left Side Division	Division Izquierda	1	2192	564	15
7	P13343	Divisão Direita	Right Side Division	Division Derecha	1	2192	564	15
8	P12431	Tampo Suprior Nicho	Table Top Niche	Table Top Niche	1	879	500	15
9	P12441	Tampo Inferior Nicho	Superficie Niche Bottom	Superficie Niche Bottom	1	879	480	15
10	P12439	Tampo Nicho	Surface Niche	Nicho de Superficie	1	879	214	15
11	P13348	Tampo Sapateira (1 ld s/ Pintura)	top Shoe (1 side without painting)	Top Tennis (1 lado sin pintar)	1	879	450	15
12	P12430	Tampo Sup. Gaveta	Table Top Drawer	Table Top cajón	1	879	500	15
13	P13287	Frete Pé	front Foot	Frete pie	1	2691	50	15
14	P11439	Prateleira	Shelf	Estante	1	879	450	15
15	P13460	Prateleira Sapateira	Shoe shelf	Estante del zapato	2	804	426	15
16	P12309	Traseiro Pé	Back Bottom Frame	Zocalo Traseiro	1	2661	50	15
17	P13536	Divisão Pé	Division Bottom Frame	Division Zocalo	5	567	50	15
18	P12437	Distanciador Gaveta	Drawer Spacer	Españador del Cajón	4	680	70	15
19	P12639	Distanciador Sapateira	Spacer Shoe	Espacio de zapatos	4	455	70	25
20	P13461	Frete Sapateira	Crab front	Delante de cangrejo	2	823	68	15
21	P10604	Lateral Gaveta	Side Drawer	Lat del Cajón	6	385	88	15
22	P12433	Fundo Gaveta	Bottom Drawer	Corredizas	3	824	406	2,5
23	P12432	Traseiro Gaveta	Rear Drawer	Traseo del Cajón	3	824	88	15
24	P13347	Fundo	Back Panel	Fondo	6	2215	444	2,5
25	P13286	Rodapé Lateral	Side footer	Pie de página Side	2	582	50	15
26	P13480	Travessa Porta Superior	Mischievous Superior Door	Travieso Puerta Superior	1	879	50	15
27	P12444	Travessa Central	Central Mischievous	Travieso central	2	879	50	15
28	P12443	Divisão Superior Nicho	Superior division Niche	Nicho División Superior	2	305	214	15
29	P12445	Divisão Inferior Nicho	Lower division Niche	Baja Niche división	1	339	177	15
30	P12442	Painel da TV	TV panel	Televisor de pantalla	1	870	619	15
31	P13346	Porta	Door	Puerta	2	2176	887	15

4406 - Roupeiro Advance Teka Sensitive C| Carvalho Sensitive

32	P13482	Frete Gaveta Carvalho	Front drawer	Frete de cajón	3	868	220	15
33	P13483	Porta Superior Carvalho	Superior Door	Puerta Superior	2	660	435	15
34	P13481	Moldura Supeior Carvalho	Higher frame	Marco superior	1	2697	70	15



Atenção com a cor do acabamento!
Em caso de assistência solicitar o código de acordo com a cor da peça.

Medidas em mm

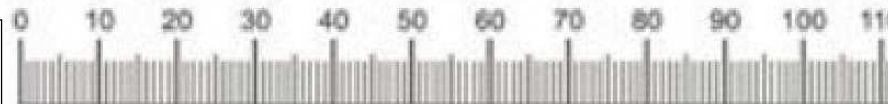

Cod. Qnt.		Cod. Qnt.		Cod. Qnt.		Cod. Qnt.		Cod. Qnt.		Cod. Qnt.		Cod. Qnt.		Cod. Qnt.		Cod. Qnt.				
A 12	B 174	C 20	D 66	E 18	F 36	G 12	H 12	I 2	J 166	K 30	L 37	M 60	N 10	O 8	P 7	Q 7	R 4			
Parafuso Bigfix 33160	Parafuso 3,5x14 CP 25736	Parafuso Corrediza 6x12 22396	Paraf. Soberbão 7x40 25691	Parafuso 4x14 CC 25673	Cavilha 6x30 24603	Tambor Minifix 22388	Tampa Tambor Minifix 25682 - Champagne	Cavilha 6x60 30517	Prego 10x10 20179	Presilha Fundo 24099	Cantoneira 20x20x42 26557	Tampa Soberbão 26558 - Champagne 32704 - Teka	Cavilha 8x30 20043	Parafuso 3,5 x35 CF 29242	Sapata Plástica 32821 - Teka	Sapata Plástica L 33168 - Teka	Suporte Cabideiro 20039			
Z 1	W 4	AA 1	AB 2	AC 2	AD 1	AE 1	AF 3	AG 2	AH 2	AI 1	AJ 1	AK 2	AL 1	AM 1	S 6	T 24	U 10	V 15	X 12	Y 6
Suporte Prateleira 33200 - Champagne	Suporte Prateleira 25681 - Champagne	Sache de cola 20g 25676	Puxador Core 32mm 31183	Cabideiro Oblongo 872mm 31252	Trilho Inferior 2667mm 33285	Trilho Superior 2667mm 31929	Kit corredeiras Telescópica 3 Pares Macho e Fêmea 33431	Parafuso 4,0 x 20 CF (Emb. c/ pux. ponto) 33431	Bucha do Pivotante 33388	Dobradiça Pivotante Direita 33368	Dobradiça Pivotante Esquerda 33369	Kit corredeiras metálicas 2 Pares Macho e Fêmea 21611	Adesivo THB 31363	Kit Fecho Toque 33367	Parafuso 3,5x12 CC 25725	Parafuso 3,5x14 CF 33067	Parafuso 3,5x12 CF 25683	Parafuso 3,5x25 CF 24648	Parafuso 3,5x12 CP (emb. c/ Suo. Cabideiro) 25671	Suporte Triângular 30094
AN 4	AO 2	AP 3	AQ 3	AR 1	AS 4	AT 4	AU 4	AV 32	AX 2	AY 2	AZ 1	BA 10	BB 4	BC 4						
Cantoneira U 2176mm 33356	Puxador Citrino 640mm 31184	Puxador Citrino 416mm 31185	Perfil H 2220mm 33426	Passa Fio 34061	Rodizio Inferior 33789	Guia Superior 4mm 33155	Guia Superior 6mm 34045	Parafuso 3,5x12 CF 33196	Parafuso 3,5x16 CC 33196	Freio da Porta 33791	Parafuso 3,5 x 16 CP (Emb. Kit trava painel) 25672	Parafuso 3,5 x 30 CF (Emb. com puxadores) 29242	Dobradiça Super Curva 23272	Caíço Dobradiça 23273						

Kit Sistema de Correr - 33789

Roupeiro Advance 4 Portas/ Advance 4 wardrobe doors/ Avance 4 puertas de los armarios

1º Passo / Step / Paso

Fixar as Divisões Pé (17) com Parafuso Soberbão (D). Após fixar Frente Pé (13) e Traseiro Pé (16) nas Divisões Pé (17) e no RodaPé Lateral (25), com Cantoneira (L) e Parafuso (B) /
 Fix the pre rooms (17) with screw Superb (D). After fixing Front Foot (13) and Rear Foot (16) in Divisions foot (17) and (25) footer Side, with bracket (L) and screw (B) /
 Fijar las habitaciones pre (17) con el tornillo Superb (D). Después de la fijación del pie delantero del pie trasero (13) y (16) en las Divisiones pies (17) y (25) de pie de página a lado, con tornillo de soporte (L) y (B).

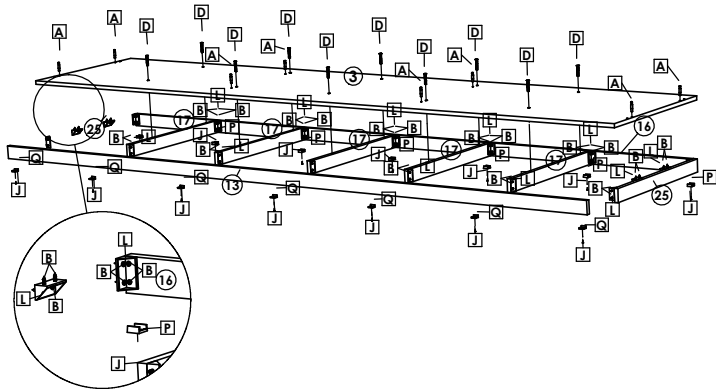

Lebrando que o Pé terá um Recuo de 3mm /
 Recalling that the foot has a kickback 3mm /
 Recordando que el pie tiene una 3mm contragolpe.

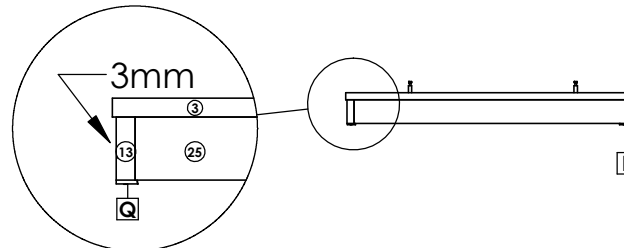

Utilizar Sapata (Q) na Frente Pé (13) e Sapata (P) no Traseiro Pé (16) /
 Use shoe (Q) on Front Foot (13) e shoe (P) in the Rear Foot (16) /
 Use calzado (Q) en el frente del pie (13) e zapato (P) en el pie trasero (16).

2º Passo / Step / Paso

Para fixar os Tampos (5, 8, 10, 12) e as Divisões (28, 29) usar Parafuso (D). Já nas Travessas (27) usar Cavilha (N) e nas Divisões (28) Cavilha (I) /
 To fix the times (5, 8, 10, 12) and Divisions (28) y (29) using screw (D). Já nas Travessas (27) usar Cavilha (N) e nas Divisões (28) Cavilha (I) /
 Sleepers already in use pin (27) and (N) in Divisions (28) Pin (I) /
 Para fixar los tiempos (5, 8, 10, 12) y Divisiones (28) y (29) utilizando el tornillo (D). Durmientes que ya están en uso pin (27) y (N) en las Divisiones (28) Pin (I).

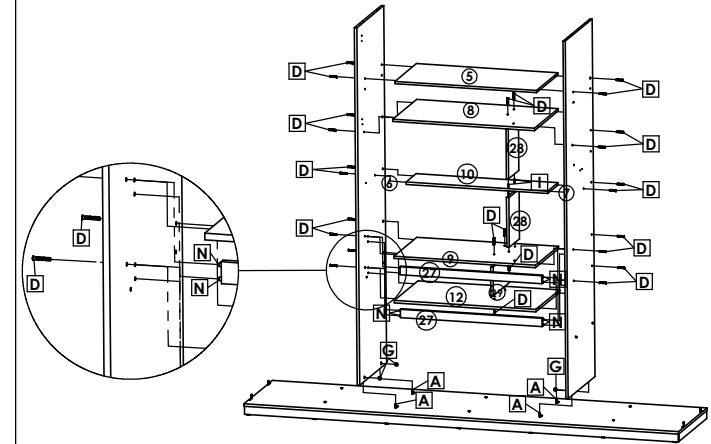

3º Passo / Step / Paso

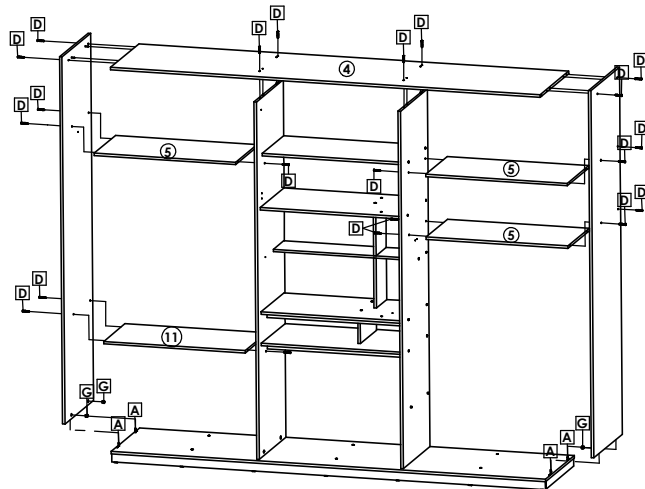

4º Passo / Step / Paso

Fixar os Fundos (24) com Pregos (J), Presilha (K), e Perfil H (AQ) /
 Fix the Funds with (24) Nail (J), Loop (K), and Profile H (AQ) /
 Fijar los Fondos con (24) clavo de (J), (K) y Loop Perfil H (AQ).

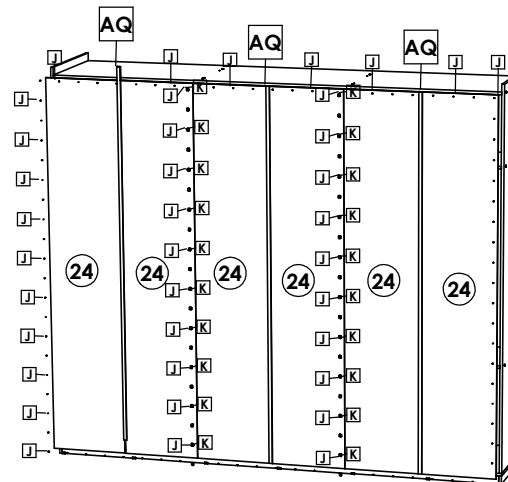

5º Passo / Step / Paso

A Moldura (34) possui um rasgo que serve de guia no posicionamento das Cantoneiras (L) /
 The frame (34) has a slot guide serves the positioning of Angles (L) /
 El bastidor (34) tiene una ranura de guía sirve para el posicionamiento de Angles (L).

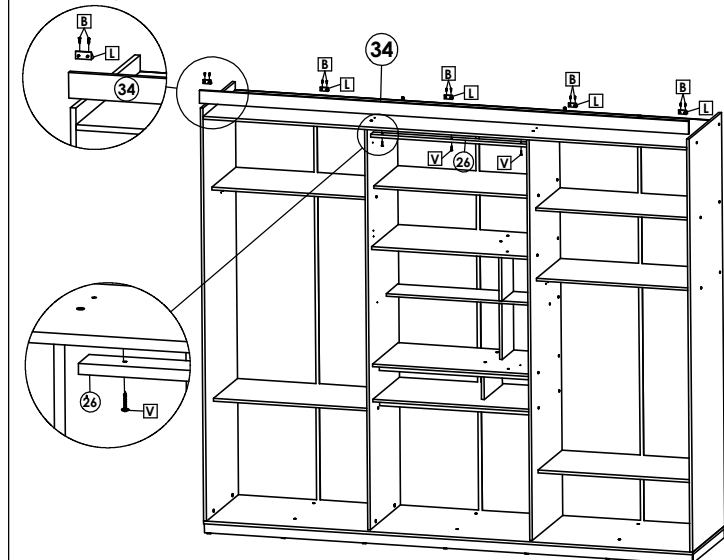

Roupeiro Advance 4 Portas/ Advance 4 wardrobe doors/ Avance 4 puertas de los armarios

6º Passo / Step / Paso



Fazer o encaixe do Trilho Superior **AE** no Tampo Superior **4** /
Do Rail Superior **AE** snaps into Table Top **4** /
Hacer Rail Superior **AE** encaja en la mesa **4**.

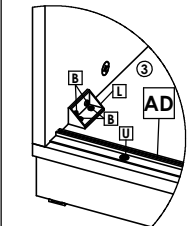
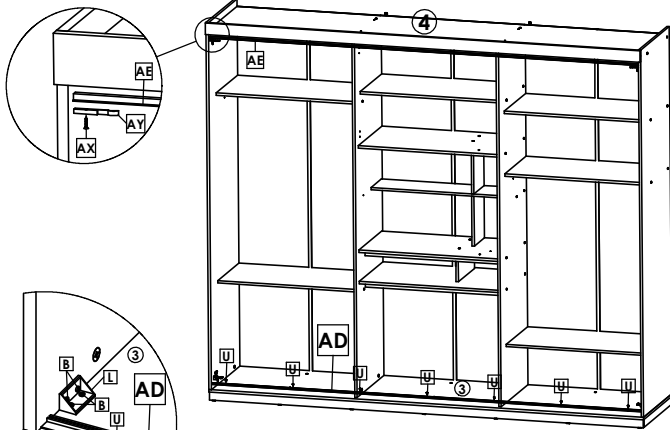

Posicionar o Trilho Inferior **AD** á 10mm da Borda do Tampo Inferior **3** /
Place the Bottom Rail **AD** is 10 mm from the Bottom Surface Edge **3** /
Coloque el riel inferior **AD** es de 10 mm desde el borde inferior de la superficie **3**.



7º Passo / Step / Paso

Distanciador Gaveta/ Spacer drawer / Espaciador del cajón

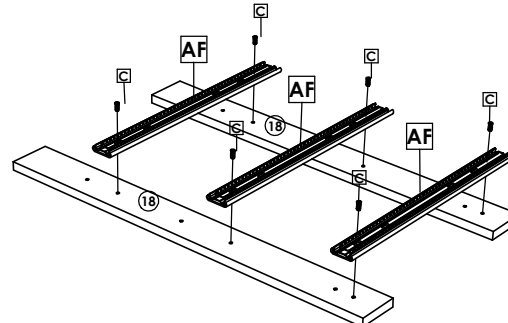

Distanciador Sapateira/ Spacer Shoemaker/ Espaciador cangrejo

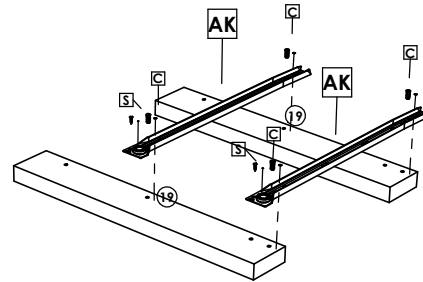

Antes de fixar os Distanciadores **18** e **19** alinha-los aos Tamos Superiores **11** e **12** /
Before attaching the spacers **18** and **19** aligns them to the Superior Tops **11** and **12** /
Antes de colocar los separadores **18** y **19** de ellos se alinea al Superior Tops **11** y **12**.

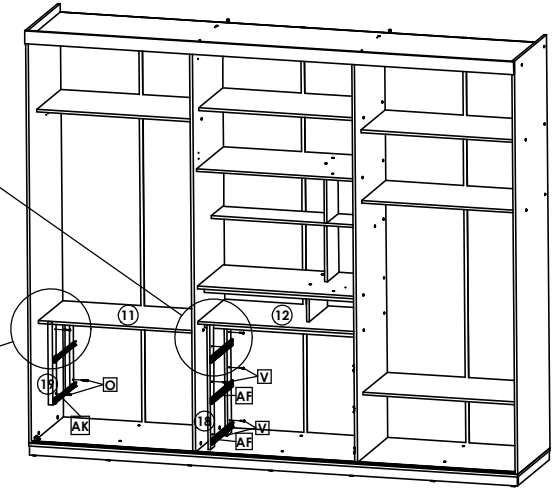
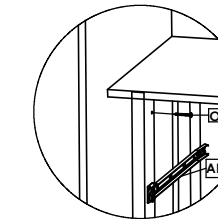
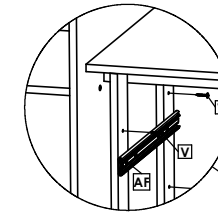

8º Passo / Step / Paso

Montagem Gaveta/ Mounting Drawer / Montaje de cajón.

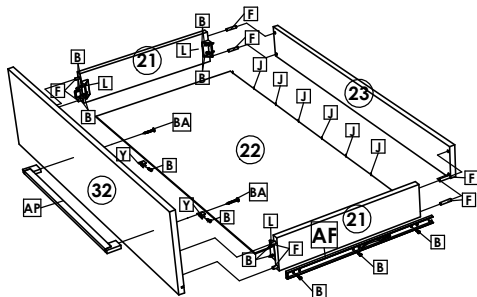

Montagem Sapateira/ Shoe mount/ Montaje del zapato.

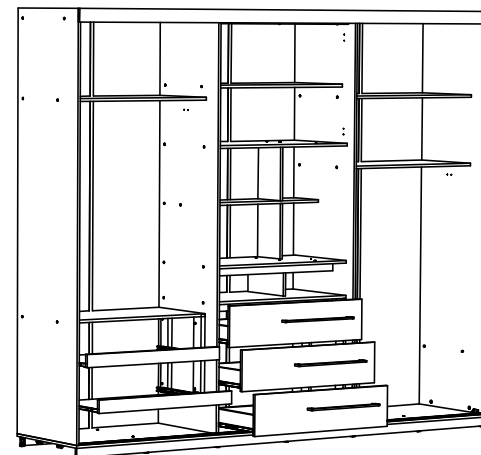
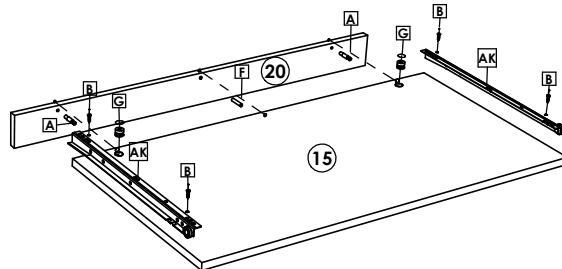

9º Passo / Step / Paso



Utilizar Parauso **X** na fixação do Suporte Cabideiro **R** /
Use screw **X** in fixing the Coat Rack Support **R** /
Utilice el tornillo **X** de fijación del soporte del estante del escudo **R**.

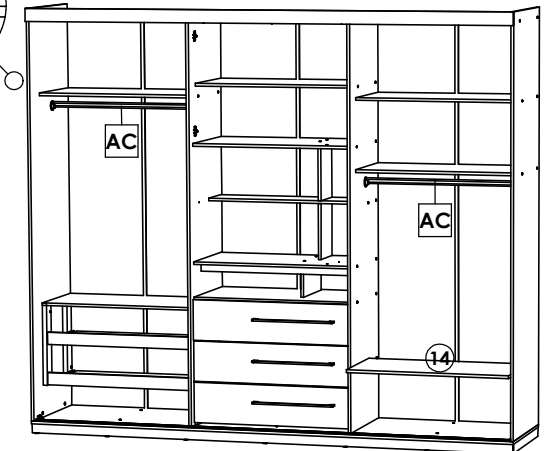
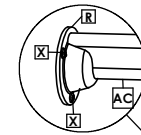

Roupeiro Advance 4 Portas/ Advance 4 wardrobe doors/ Avance 4 puertas de los armarios

10º Passo / Step / Paso

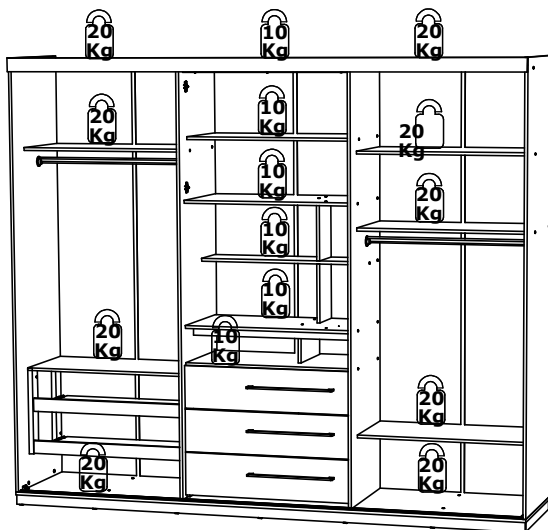

! **Peso Suportado por Gaveta e Sapateira/ Supported by weight drawer and crab/ Con el apoyo de cajón de peso y cangrejo.** **5 Kg**

Montagem das Portas/ Installation of doors / La instalación de puertas.

! **ATENÇÃO!**

Iniciar a montagem dos Guias Superiores **AT** 4mm com Capa Branca posicionando a 32mm da Cantoneira **AN**.

Após fixar os Guias Superiores **AU** 6mm com Capa Cinza na parte central das Portas, posicionando á 64mm da Cantoneira **AN**.

ATTENTION!

Start the assembly of the Higher Guides **AT** 4mm with White Cover positioning of 32mm bracket **AN**.

After fixing the Superior Guides **AT** 6mm with gray cover in the central part of the doors, positioning will 64mm of bracket **AN**.

ADVERTENCIA!

Iniciar el montaje de la **AT** 4mm Guías Mayores con tapa blanca posicionamiento de soporte de 32 mm **AN**.

Después de fijar el **AU** 6mm guías superior con cubierta gris en la parte central de las puertas, el posicionamiento será de 64 mm de soporte **AN**.

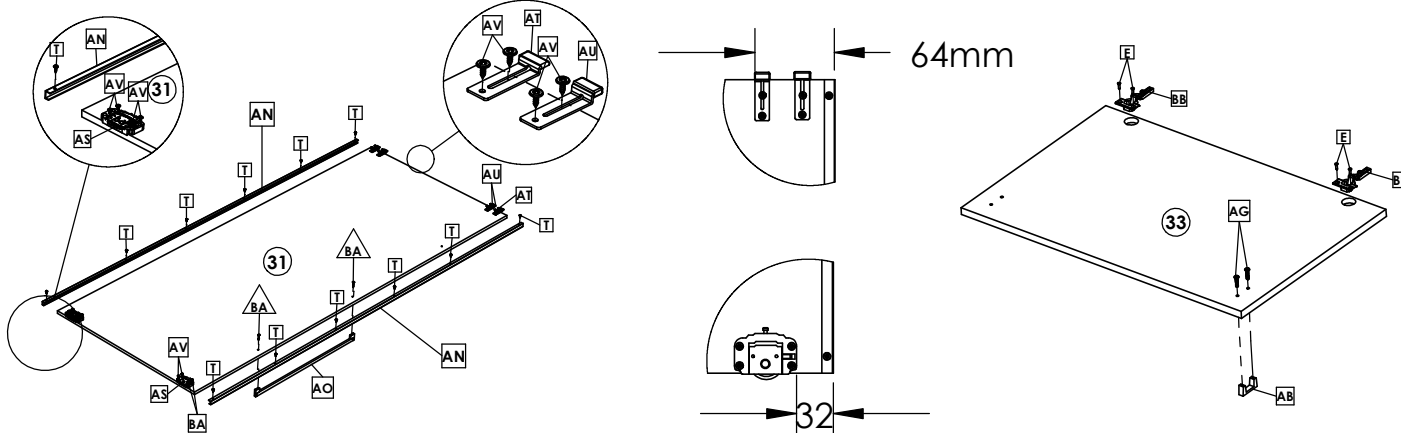

11º Passo / Step / Paso

Fixar o Fecho Toque **AM** pelo seu Primeiro Furo/

Fix the locking Touch **AM** for his first hole/

Fijar el tacto de bloqueo **AM** para su primer agujero.

Fixar o Painel **(30)** com Parafuso **U** /

Fix the panel **(30)** with screw **U** /

Fijar el panel **(30)** con el tornillo **U**.

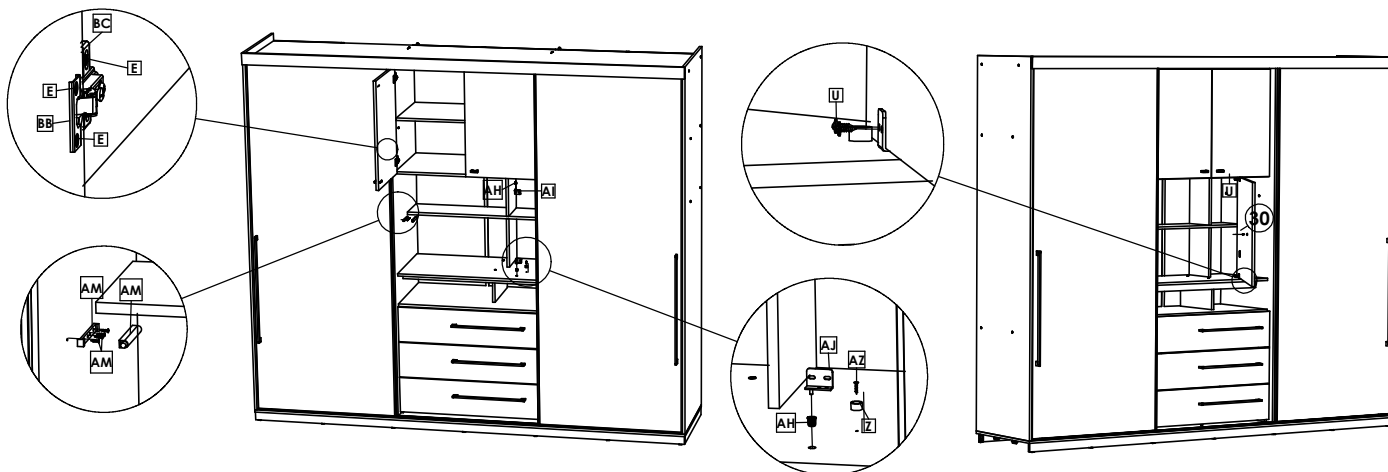

12º Passo / Step / Paso

Sugestão na organização dos Fios da TV/ Suggestion in organizing the TV wires/ Sugerencia en la organización de los cables de TV.

! **Estes Acessórios Não acompanham o Produto/ These accessories do not come with the product/ Estos accesorios no vienen con el producto.**

Organizador de Fios/ Wire organizer / Organizador del hilado.

O Organizador de Fios é um ótimo auxiliar na instalação, envolvendo todos os Fios que além de proporcionar mais espaço, deixa tudo bem organizado.

The Wire Organizer is a great help in the installation, involving all the wires that besides directly providing more space leaving everything well organized.

El Organizador Wire es una gran ayuda en la instalación, además la participación de todos Fios que a proporcionar más espacio directamente de jando todo bien organizado.



Régua energizada/ Ruler energized / Regia energizado.

Esta Régua permite uma melhor organização interna na fiação da TV, oportunizando também alimentar Baterias de Smartphones, DVD, Receptor de Parabólica, Secador de Cabelo, Prancha Alisadora, etc.

This rule allows a better internal organization in the TV wiring, providing opportunities also feed Smartphones batteries, DVD, Receiver Satellite TV, Hairdryer, Wiper Board, etc.

Esta regla permite una mejor organización interna en el cableado de TV, proporcionando oportunidades también se alimentan de baterías Smartphones, DVD, Receptor de TV vía satélite, Secador de pelo, tabla de limpiaparabrisas, etc.



Roupeiro Advance



ATENÇÃO



ATENÇÃO

Painel para TV de 32 Polegadas/ Panel TV 32 Inches / Panel TV 32 pulgadas.

Medidas de TV até/ TV measures to/ Medidas de TV a: AxLxX

- 48,5x74,5x7,5 cm

Peso Suportado pela TV/ Weight Supported by TV/ Peso Con el apoyo de TV.



A imagem é meramente ilustrativa, a TV não acompanha o Produto/

The image is merely illustrative, the TV is not included with the product/

La imagen es meramente ilustrativa, el televisor no se incluye con el producto.