

CLOSET DIAMANTE - 2 GAVETAS

Closet **Diamante** - 2 drawers
Closet **Diamante** - 2 cajones

Código **150267** | Revisão 00

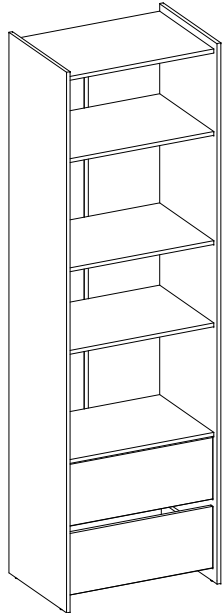

PESO MÁXIMO SUPORTADO PELAS PEÇAS, SENDO ESTE DISTRIBUÍDO UNIFORMEMENTE.

Maximum weight supported by parts, being this evenly distributed.
Peso máximo soportado por las partes, siendo esta distribuido uniformemente.

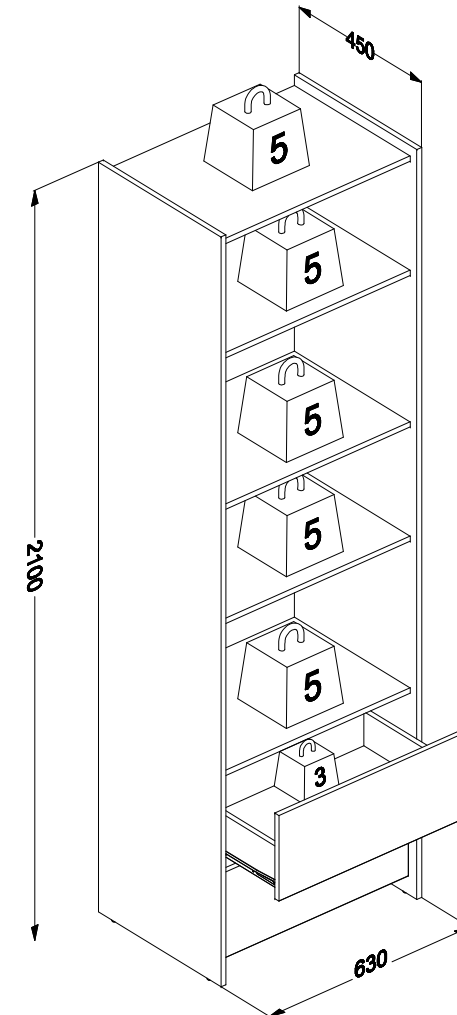

Você vai precisar de/ You will need / Usted necesitará

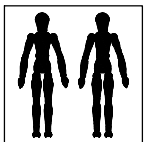

2 Pessoas
2 People
2 Personas

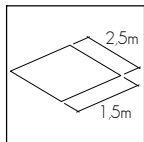

Espaço recomendado para montagem
Recommended space for assemble
Espacio recomendado para el armado

Ferramentas não inclusas
Tools not included / Herramientas no incluidas

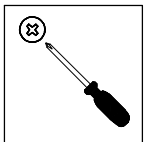

Chave Phillips
Screwdriver Phillips
Destornillador cruz

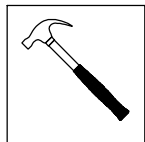

Martelo
Hammer
Martillo









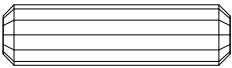
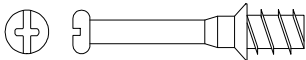

* PESO EM KG/ Weight in Kg/ Peso en Kg
DIMENSÕES EM MM/ Dimensions in mm/ Dimensiones en mm

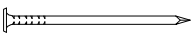
IDENTIFICAÇÃO DOS ACESSÓRIOS / IDENTIFICATION OF ACCESSORIES/ IDENTIFICACIÓN DE ACCESORIOS

NOTAS: A separação dos acessórios antes de iniciar a montagem facilitará a mesma. Os parafusos e cavilhas estão na escala real. Em caso de dúvida na identificação, coloque o acessório sobre a imagem.

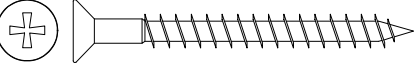
NOTES: The separation of the accessories before you start the assembly will facilitate the same. The screws and dowels are in real scale. In case of doubts about the identification, place the accessory on the image.

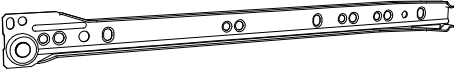
NOTAS: La separación de los accesorios antes de comenzar el armado facilitará el mismo. Los tornillos y taquetes son en escala real. En caso de dudas sobre la identificación, coloque el accesorio en la imagen.

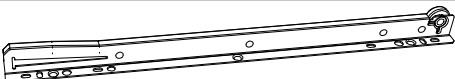
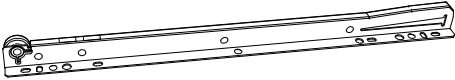
A		Cavilha Wooden Dowel Pin	8x30 mm	32
B		Haste minifix simples Simple minifix screw Tornillo minifix simple	-	20
C		Tambor minifix Drum lock Tambor minifix	12 mm	20
D		Tapa furo adesivo Bore patch adhesive Tapones adhesivo	-	08
E		Prego Nail Clavo	10 x10	55
F		Sapata redonda Small plastic foot Pie plástico	14 mm	04
G		Suporte de prateleira Shelf bracket Soporte de repisa	6x8 mm	08
H		Parafuso chato Flat head screw Tornillo de cabeza plana	3,0x14 mm	16
I		Parafuso chato Flat head screw Tornillo de cabeza plana	4,5x45 mm	04
J		Perfil "H" "H" profile Perfil "H"	-	01
K		Cola Glue Pegamento	13g	01
L		Corrediça lateral esquerda Metallic slide the left field Corredera lateral izquierda	350 mm	02
M		Corrediça lateral direita Metallic slide the right field Corredera lateral derecha	350 mm	02
N		Corrediça gaveta esquerda Drawer slide left Corredera izquierda cajón	350 mm	02
O		Corrediça gaveta direita Drawer slide right Corredera derecha cajón	350 mm	02

IDENTIFICAÇÃO DAS PEÇAS/ PARTS IDENTIFICATION/ IDENTIFICACIÓN DE LAS PIEZAS

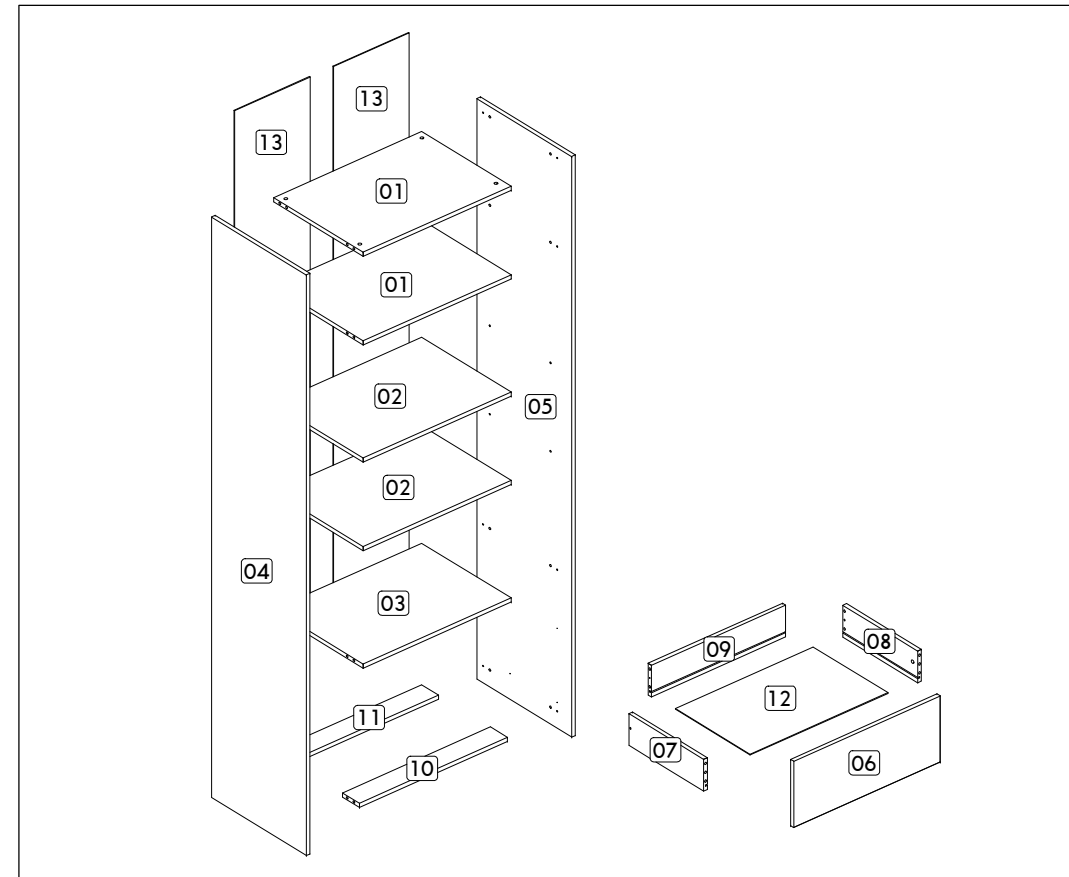

Nº	DESCRIÇÃO - DESCRIPTION - DESCRIPCIÓN	MEDIDAS - MEASURES - MEDIDAS (mm)	QTD.
01	Base - Base - Base	600 x 425 x 15	02
02	Prateleira móvel - Movable shelf - Repisa móvil	600 x 425 x 15	02
03	Base gavetas - Drawer base - Base cajón	600 x 425 x 15	01
04	Lateral esquerda - Left side - Lateral izquierda	2100 x 450 x 15	01
05	Lateral direita - Right side - Lateral derecha	2100 x 450 x 15	01
06	Frente de gaveta - Drawer front - Frente del cajón	594 x 240 x 15	02
07	Lateral de gaveta esquerda - Left side of drawer - Lateral izquierda del cajón	355 x 115 x 15	02
08	Lateral de gaveta direita - Right side of drawer - Lateral derecha del cajón	355 x 115 x 15	02
09	Traseiro de gaveta - Rear of drawer - Trasero del cajón	545 x 115 x 15	02
10	Travessa frontal - Front tray - Traviesa frontal	600 x 80 x 15	01
11	Travessa traseira - Rear tray - Traviesa trasera	600 x 80 x 15	01
12	Fundo de gaveta - Bottom of drawer - Fondo del cajón	559 x 355 x 03	02
13	Costa - Backboard - Fondo	2006 x 307 x 03	02

PRÉ-MONTAGEM/ PRE-ASSEMBLE/ PRE ARMADO

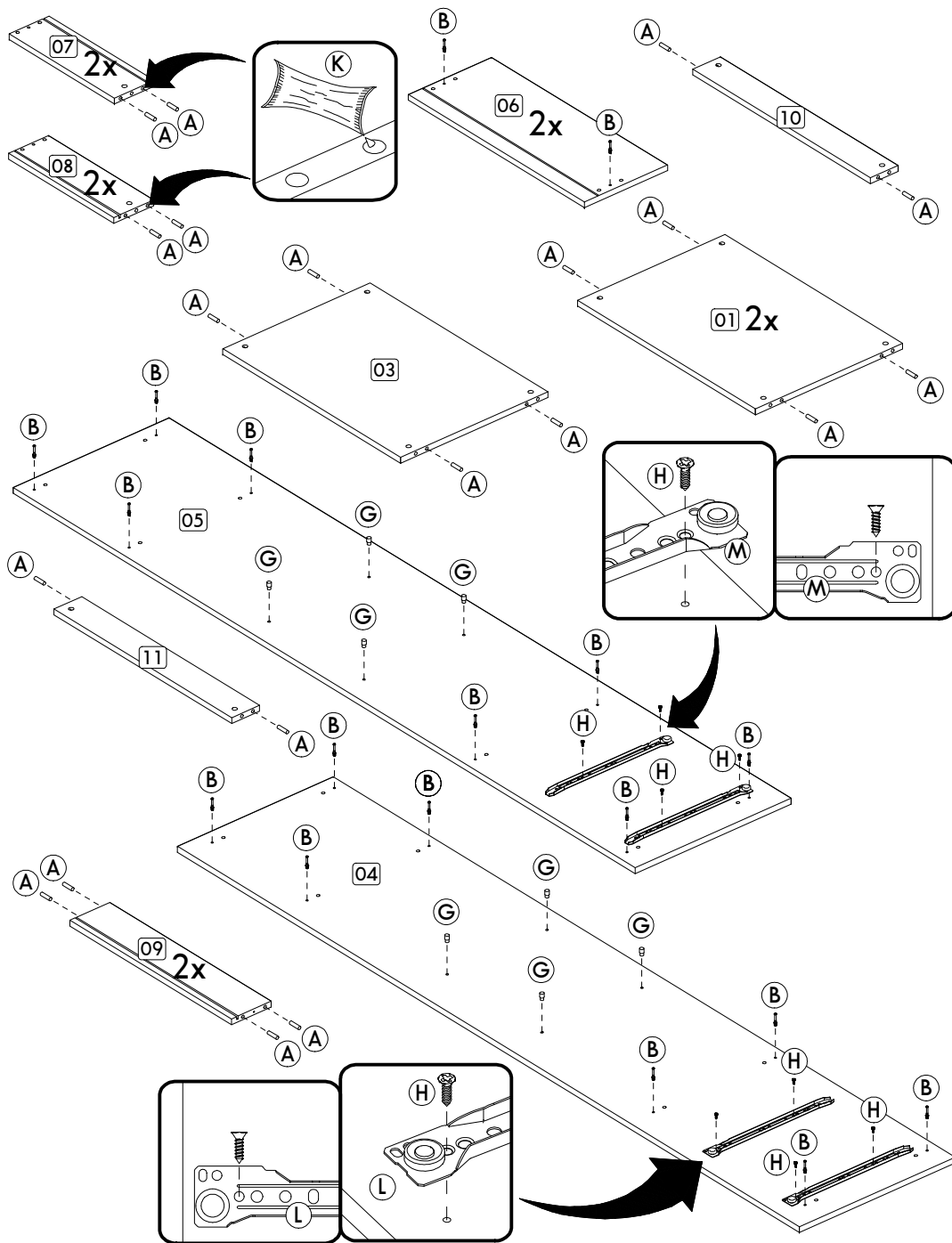

MONTAGEM/ ASSEMBLY/ ARMADO

Passo/ Step/ Paso 01

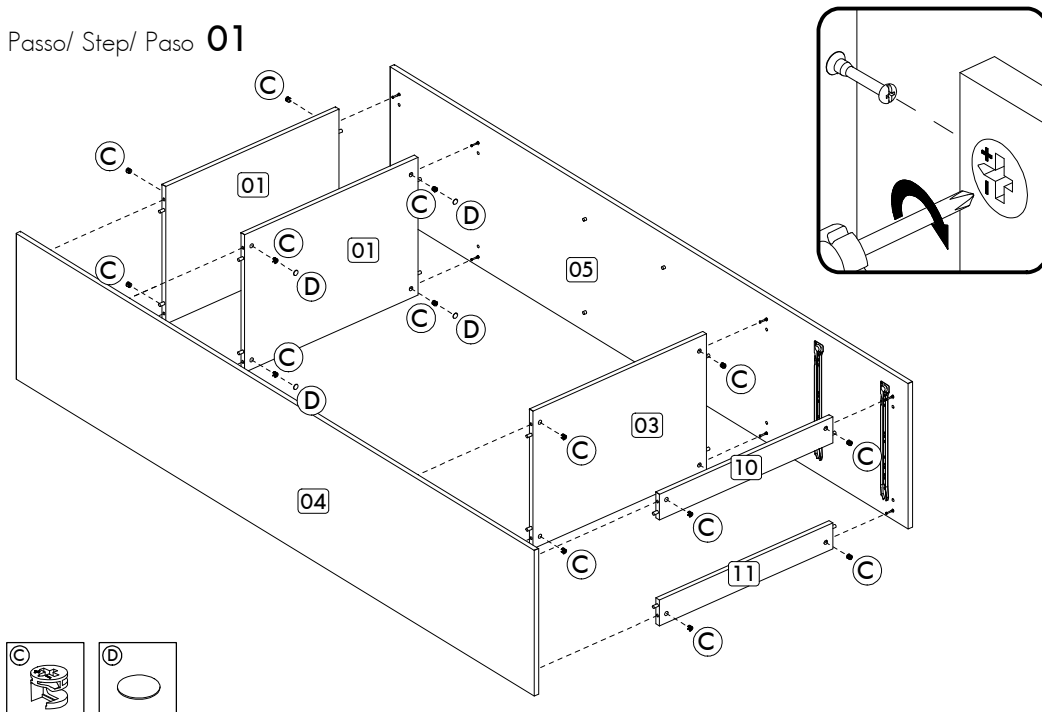

Passo/ Step/ Paso 02

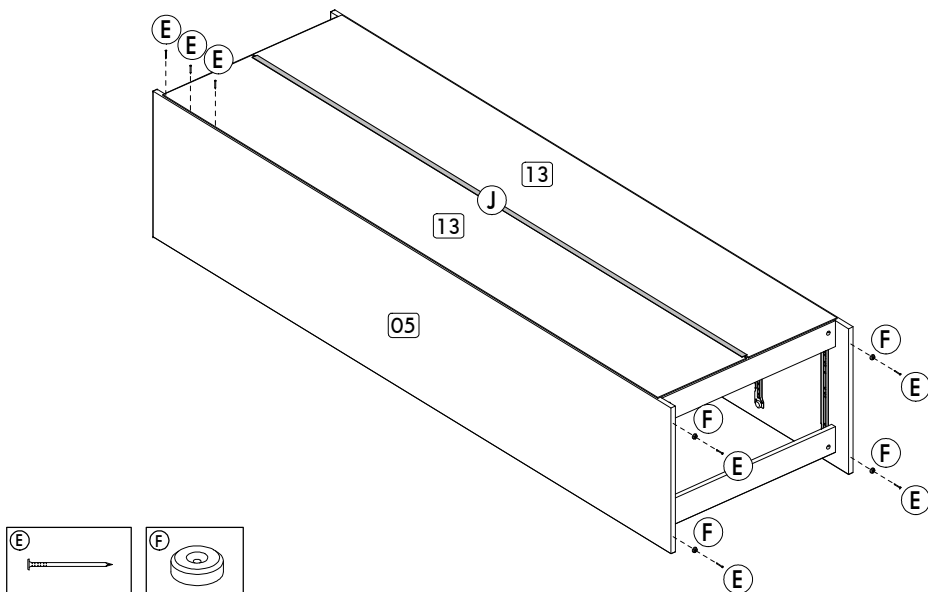

Passo/ Step/ Paso 03

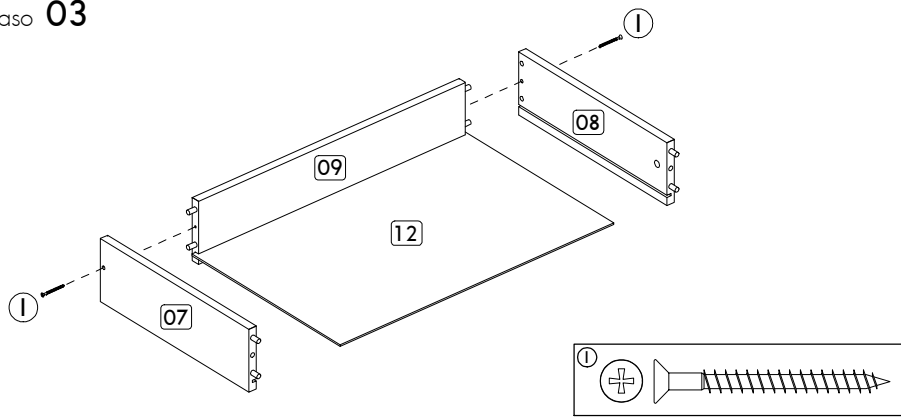

Passo/ Step/ Paso 04

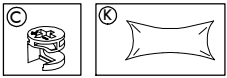
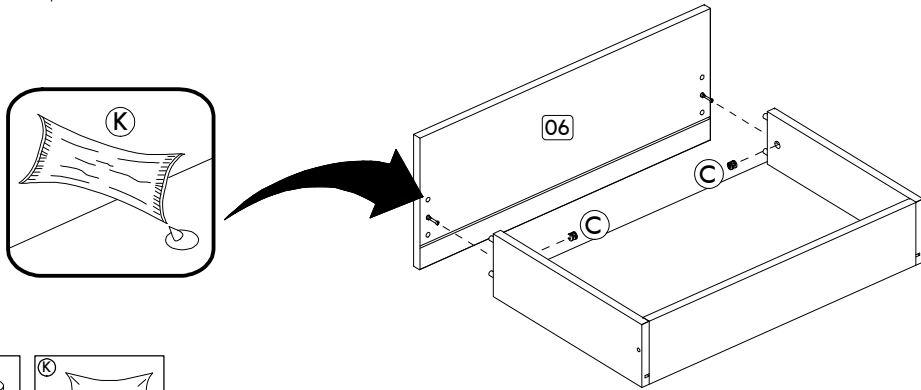

Passo/ Step/ Paso 05

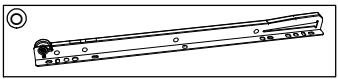
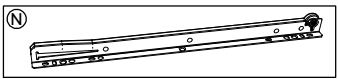
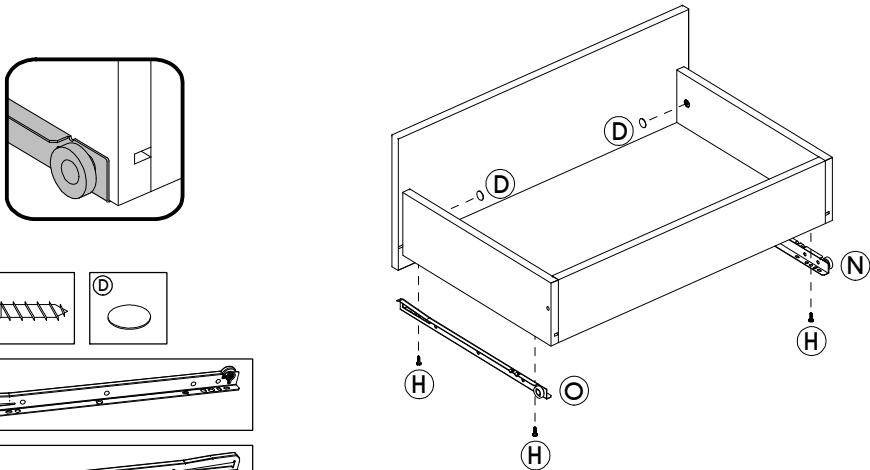

Passo/ Step/ Paso 06

