

BANCADA JAÚ

Desk Jaú
Mesa computadora Jaú

Código 1233 | Revisão 00

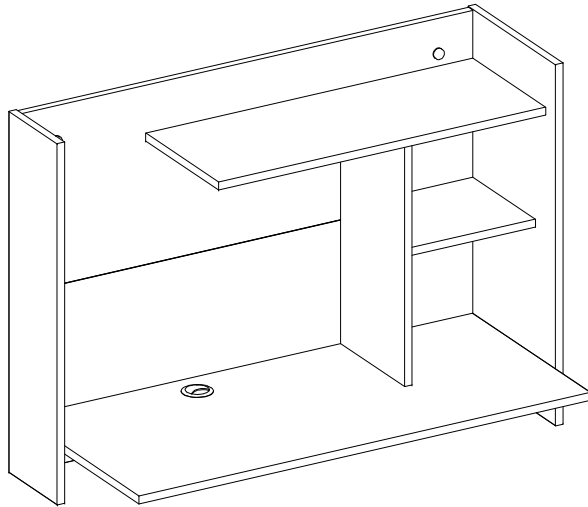

PESO MÁXIMO SUPORTADO PELAS PEÇAS, SENDO ESTE DISTRIBUÍDO UNIFORMEMENTE.

Maximum weight supported by parts, being this evenly distributed.
Peso máximo soportado por las partes, siendo esta distribuido uniformemente.

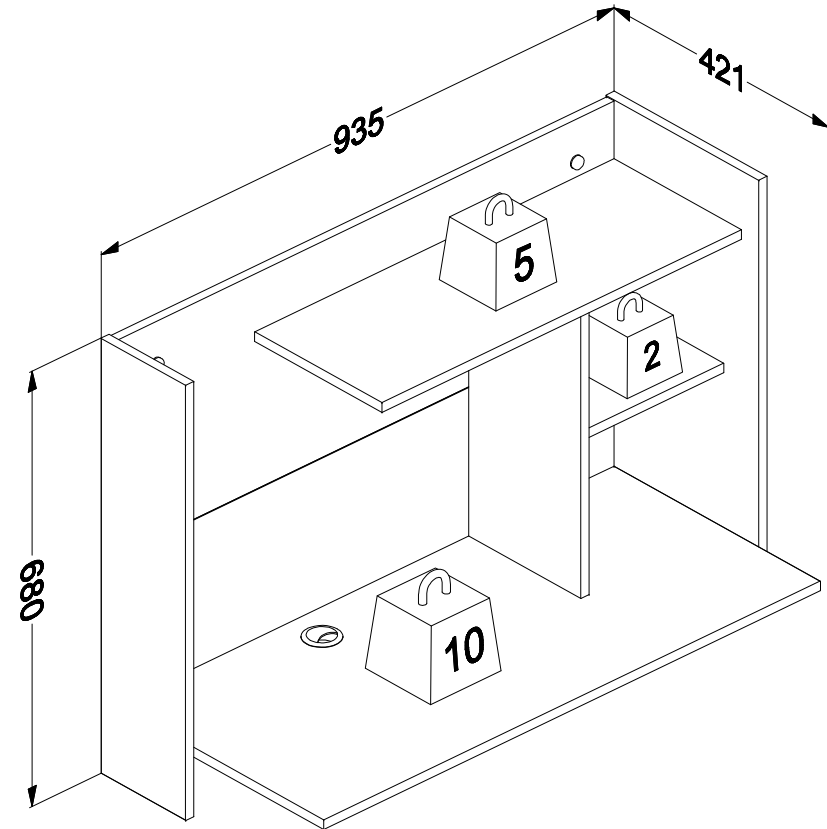

Você vai precisar de/ You will need / Usted necesitará

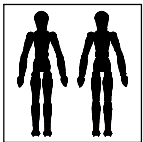

2 Pessoas
2 People
2 Personas

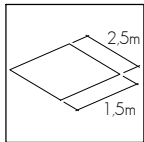

Espaço recomendado para montagem
Recommended space for assemble
Espacio recomendado para el armado

Ferramentas não inclusas Tools not included / Herramientas no incluidas

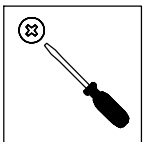

Chave Philips
Screwdriver
Destornillador cruz



Martelo
Hammer
Martillo

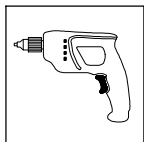

Furadeira
Drill machine
Taladro

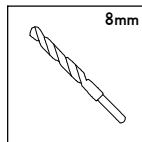

Broca
Drill bit
Taladro







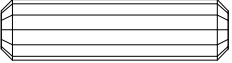
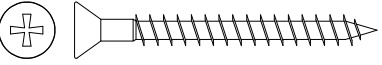
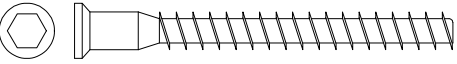
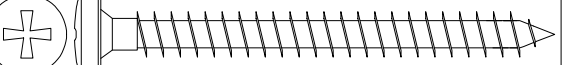

* PESO EM KG/ Weight in Kg/ Peso en Kg
DIMENSÕES EM MM/ Dimensions in mm/ Dimensiones en mm

IDENTIFICAÇÃO DOS ACESSÓRIOS / IDENTIFICATION OF ACCESSORIES/ IDENTIFICACIÓN DE ACCESORIOS

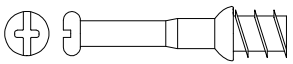
NOTAS: A separação dos acessórios antes de iniciar a montagem facilitará a mesma. Os parafusos e cavilhas estão na escala real. Em caso de dúvida na identificação, coloque o acessório sobre a imagem.

NOTES: The separation of the accessories before you start the assembly will facilitate the same. The screws and dowels are in real scale. In case of doubts about the identification, place the accessory on the image.

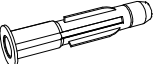
NOTAS: La separación de los accesorios antes de comenzar el armado facilitará el mismo. Los tornillos y taquetes son en escala real. En caso de dudas sobre la identificación, coloque el accesorio en la imagen.

A		Cavilha Wooden Dowel Pin	8x30 mm	22
B		Parafuso chato Flat head screw Tornillo de cabeza plana	4,0x40 mm	02
C		Parafuso estrutural Structural screw Tornillo estrutural	5,0x50 mm	13
D		Parafuso panela Pan head screw Tornillo de pan	6,0x60 mm	04
E		Chave allen Allen key Llave Allen	-	01
F		Tampa parafuso estrutural Structural screw cover Tapa tornillo estrutural	-	13
G		Haste minifix simples Simple minifix screw Tornillo minifix simple	-	01
H		Tambor minifix Drum lock Tambor minifix	12 mm	01
I		Tapa furo adesivo Bore patch adhesive Tapones adhesivo	-	01
J		Passa fios Pass wires Pasar cables	46mm	01
K		Bucha expansiva Bushing Tapón	8x50 mm	04
L		Suporte botão Button support Soporte botón	-	04
M		Tampa botão Button cover Tapa botón	-	04

IDENTIFICAÇÃO DAS PEÇAS/ PARTS IDENTIFICATION/ IDENTIFICACIÓN DE LAS PIEZAS

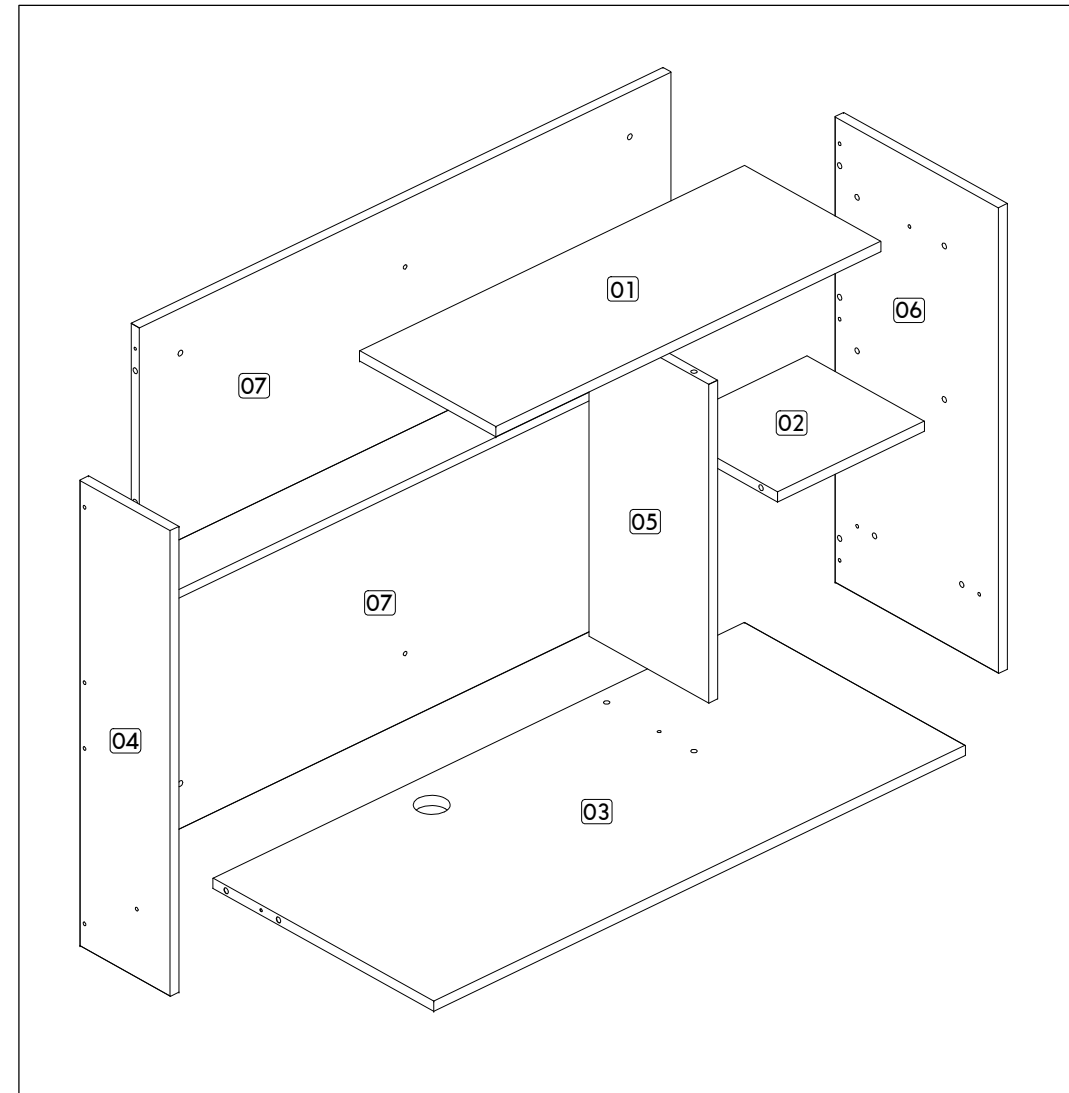

Nº	DESCRIÇÃO - DESCRIPTION - DESCRIPCIÓN	MEDIDAS-MEASURES - MEDIDAS (mm)	QTD.
01	Base superior - Top base - Base superior	656 x 250 x 15	01
02	Prateleira - Shelf - Repisa	250 x 215 x 15	01
03	Base - Base - Base	906 x 405 x 15	01
04	Lateral esquerda - Left side - Lateral izquierda	680 x 166 x 15	01
05	Divisória - Partition - Divisoria	465 x 220 x 15	01
06	Lateral direita - Right side - Lateral derecha	680 x 300 x 15	01
07	Panel - Panel - Panel	906 x 338 x 15	02

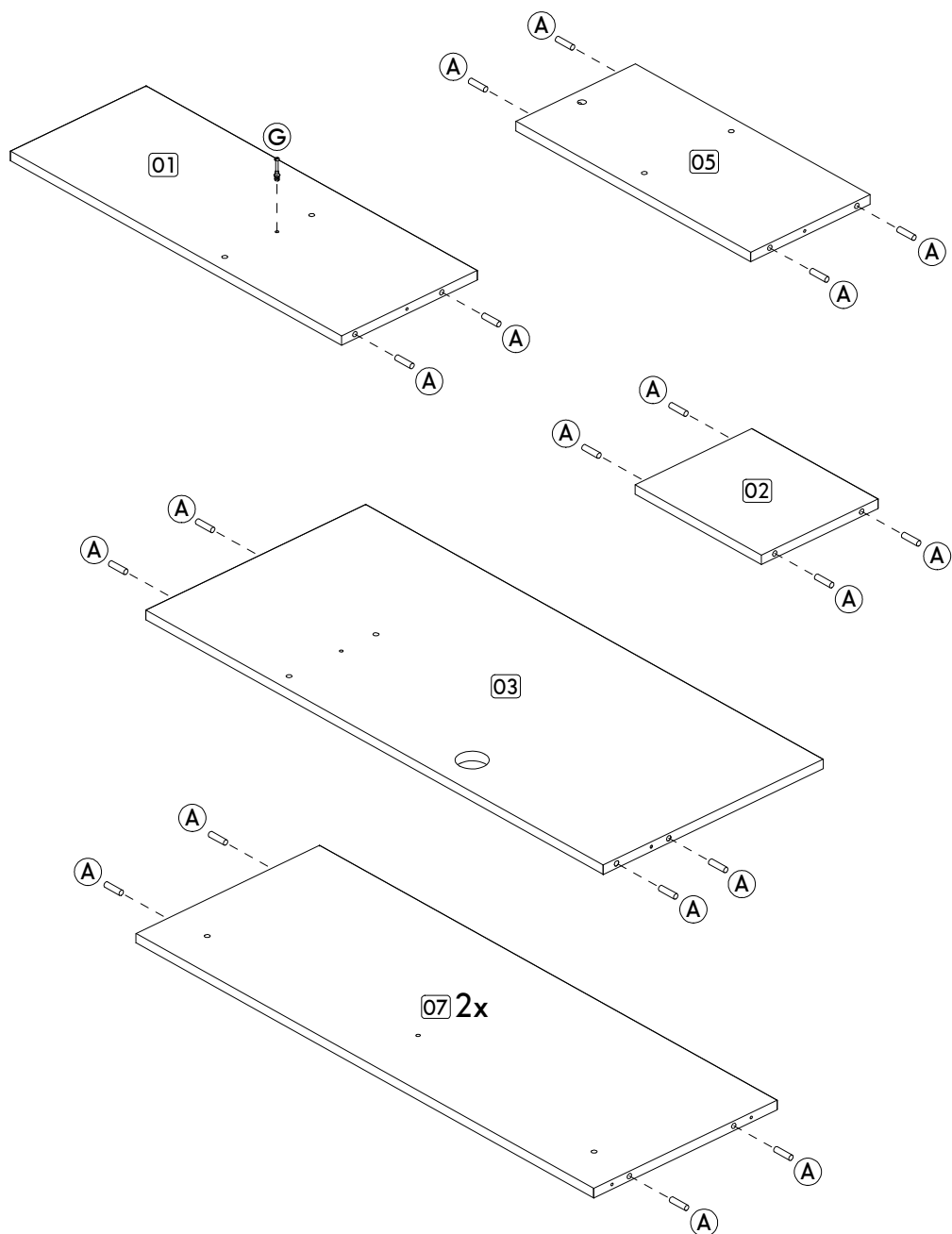

Passo/ Step/ Paso 01

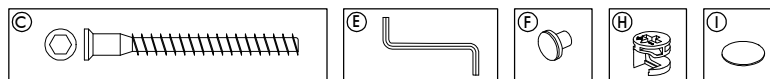
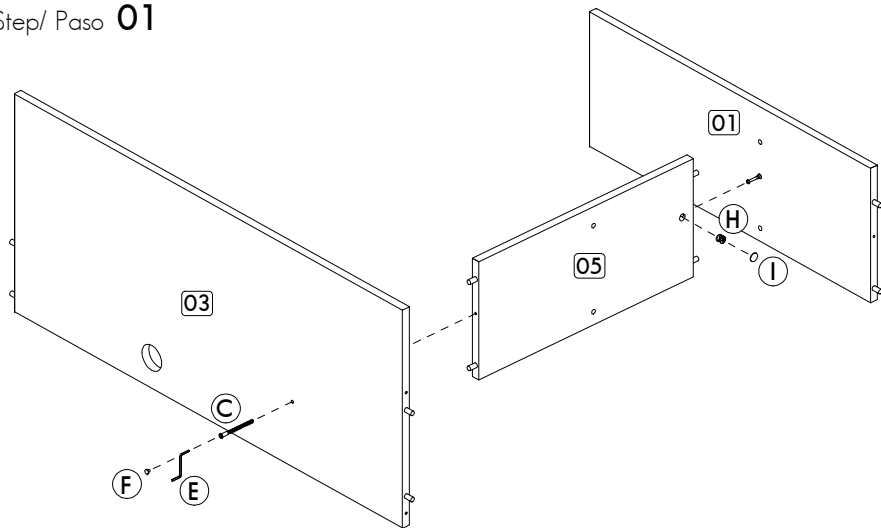

Passo/ Step/ Paso 02

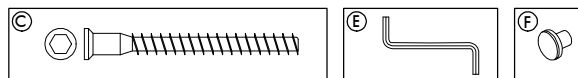
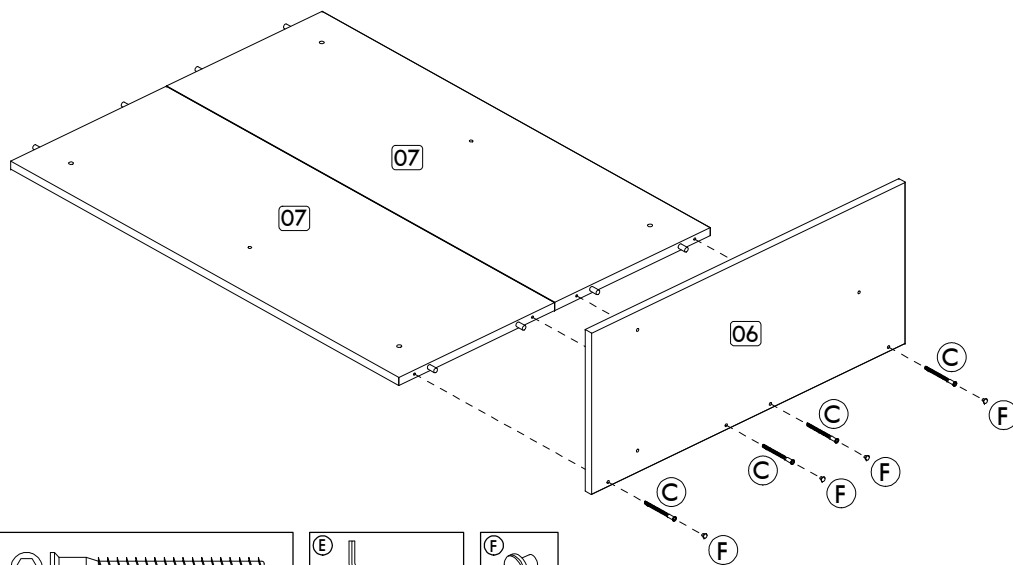

Passo/ Step/ Paso 03

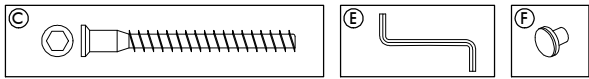
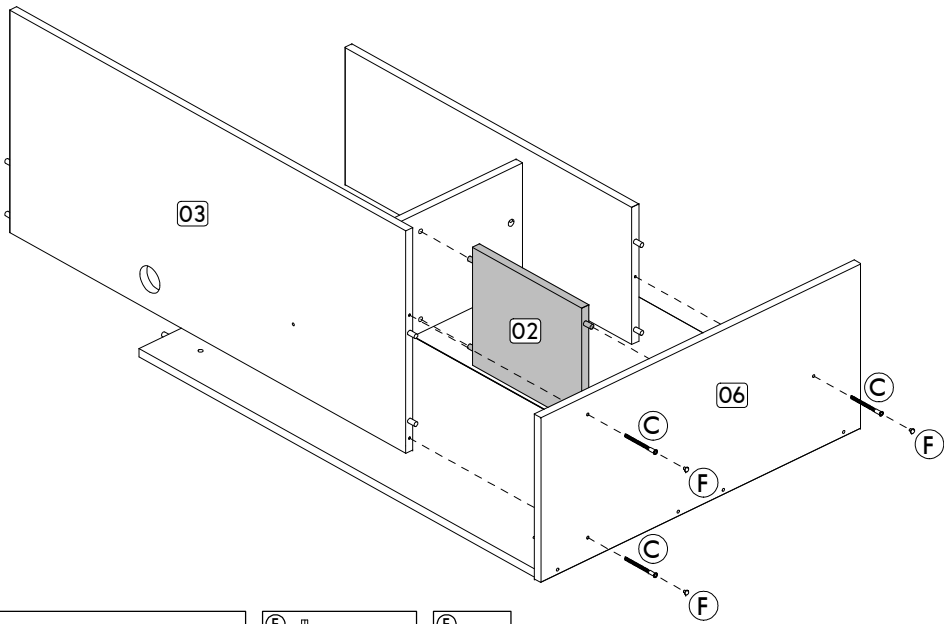

Passo/ Step/ Paso 04

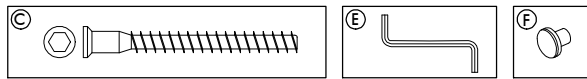
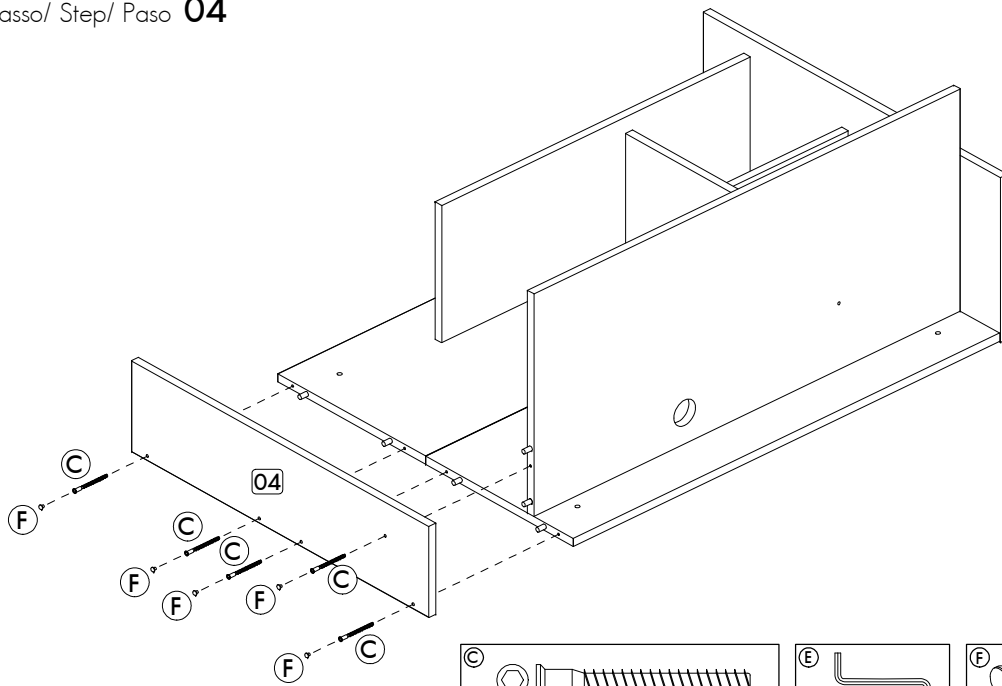

Passo/ Step/ Paso 05

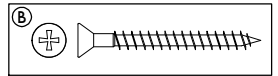
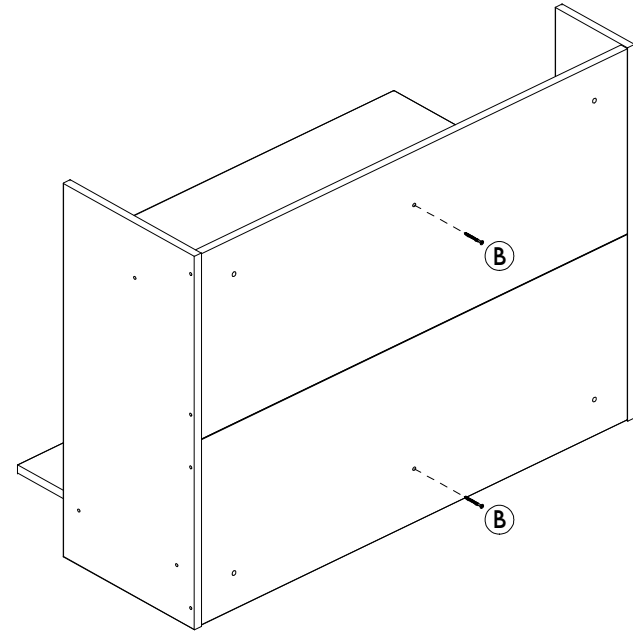

Passo/ Step/ Paso 06

