

**CÓDIGO DE PEÇAS | CODE OF PIECES | CÓDIGO DE PIEZAS**

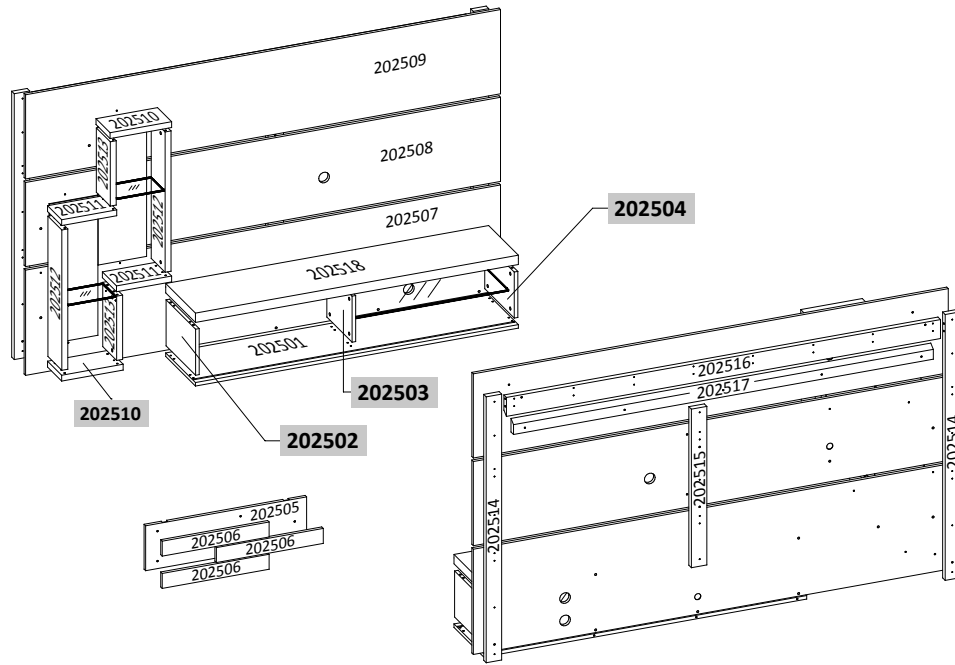

**INSTRUÇÕES**

- Prepare a montagem do móvel próximo ao local que ele ficará definitivamente e evite deslocá-lo depois de montado;  
- Forre o chão com papelão ou similar e utilize a isomanta que vem entre as peças para evitar o contato entre elas durante a montagem;  
- Monte o móvel obedecendo a ordem numérica da **seqüência de montagem (S.M.)**, identificando as peças pelo **código de peça (C.P.)** carimbado na mesma, de acordo com a tabela.

**INSTRUCTIONS**

- Prepare the assembly of the close piece of furniture to the place that it will be definitively and avoid to move after done. Will be definitively and avoid to move after done;  
- Cover the ground with cardboard or similar and use the isomanta that it comes among the pieces to avoid the contact among them during the assembly;  
- Set up the piece of furniture obeying the numeric order of the **assembly sequence (S.M.)**, identifying the pieces by **code of piece (C.P.)** stamped in the same, in agreement with the table.

**INSTRUCCIONES**

- Prepare la montaje del mobiliario proximo al lugar que estará definitivamente y evite mover después de hecho;  
- Tape la suelo con cartón o similar y use la "isomanta" que viene entre las piezas para evitar el contacto entre ellos durante la montaje;  
- Monte el mobiliario obedeciendo el orden numérico de la **sucesión de montaje (S.M.)**, identificando las piezas por el **código de piezas (C.P.)** de la misma estampado en esta, de acuerdo con la tabla.

**ASPECTO FINAL | FINAL ASPECT**

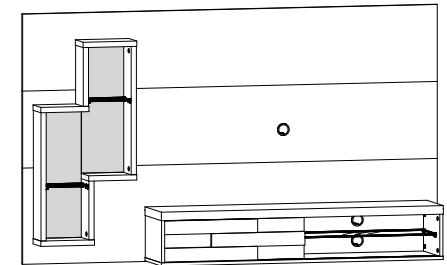

Espaço para Tv: → 1,480m ↑ 0,900m  
Dimensão do Produto: → 2,000m ↑ 1,170m ↖ 0,335m

**CUIDADOS ESPECIAIS**

**LIMPEZA:** Pano limpo umedecido em água e sabão neutro  
**BRILHO:** Flanela seca

**SPECIAL CARES**

**CLEANING:** Clean cloth humidified in water and neutral soap  
**SHINE:** Dry flannel

**CUIDADOS ESPECIALES**

**LIMPIEZA:** Tela limpia humedecida en la agua y el jabón neutro  
**BRILLO:** Franela seca

\*Dimensões em metros | Dimensions in meters | Dimensiones en metros

REF.:	DESCRIÇÃO DAS PEÇAS PIECES DESCRIPTION DESCRIPCION DE LAS PIEZAS	MATÉRIA PRIMA RAW MATERIAL	DIMENSÕES* DIMENSIONS DIMENSIONES	QUANTIDADE QUANTITY CANTIDAD
202501	Base   Base   Base	MDP	1,360 x 0,295 x 0,015	1
202502	Lateral esquerda box   Left side   Lateral izquierda	MDP	0,293 x 0,197 x 0,015	1
202503	Divisão box   Division   Divison	MDP	0,252 x 0,197 x 0,015	1
202504	Lateral direita box   Right side   Lateral derecha	MDP	0,293 x 0,197 x 0,015	1
202505	Porta deslizante   Sliding door   Puerta corrediza	MDP	0,678 x 0,192 x 0,015	1
202506	Apique da porta   Apply the door   Aplicar le puerta	MDP	0,450 x 0,064 x 0,015	3
202507	Painel inferior   Bottom panel   Panel inferior	MDP	2,000 x 0,450 x 0,015	1
202508	Painel central   Bottom panel   Panel inferior	MDP	2,000 x 0,360 x 0,015	1
202509	Painel superior   Superior panel   Panel superior	MDP	2,000 x 0,360 x 0,015	1
202510	Base/topo maior do nicho   Basis of the niche   Base del nicho	MDP	0,259 x 0,140 x 0,025	2
202511	Base/topo menor do nicho   Basis of the niche   Base del nicho	MDP	0,232 x 0,140 x 0,025	2
202512	Lateral maior do nicho   The niche side   La mayor lado nicho	MDP	0,600 x 0,138 x 0,025	2
202513	Lateral menor do nicho   Side of the Niche   Lado inf. del nicho	MDP	0,275 x 0,138 x 0,025	2
202514	Travessa traseira lateral   Side line   Lado do corril	MDP	1,137 x 0,065 x 0,025	2
202515	Travessa traseira central   Central line	MDP	0,678 x 0,065 x 0,025	1
202516	Apoio do painel   Support panel   Soporte del panel	MDP	1,828 x 0,081 x 0,025	1
202517	Apoio da parede   Support wall   Soporte del pared	MDP	1,768 x 0,052 x 0,025	1
202518	Tampo   Top   Tapa	MDP	1,360 x 0,295 x 0,025	1
	Prateleira maior   Shelf   Estanteria	VIDRO	0,640 x 0,247 x 0,005	1
1.05.02.0049	Prateleira menor   Shelf   Estanteria	VIDRO	0,199 x 0,130 x 0,005	2
	Espelho   Glass   Espejo	VIDRO	0,598 x 0,204 x 0,003	2

**ACESSÓRIOS | ACCESSORIES | ACESORIOS**

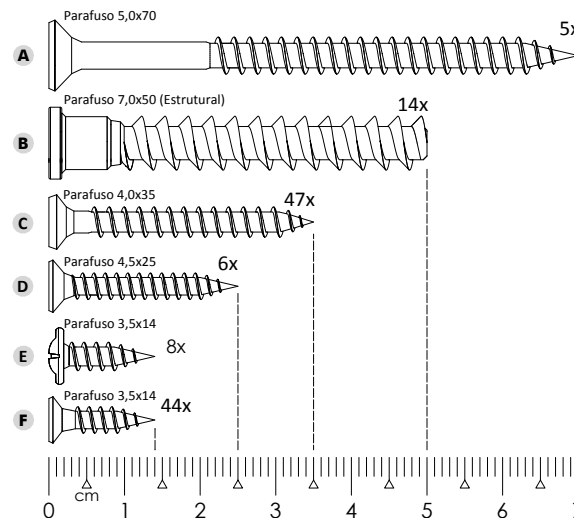

G 34x	H 20x	i 20x	J 16x
Cavilha	Pino girofix	Castanha girofix	Chapa met. fixadora
K 12x	L 1x	M 1x	N 10x
Suporte prateleira	Kit roldana	Trilho plástico	Fita dupla face
O 3x	P 5x	Q 20x	R 4x
Passa fio	Bucha para parede	Tapa furo adesivo	Sache de cola
S 1x			
Logomarca			

**1º PASSO | PASS | PASO**

PEÇAS  
PIECES  
PIEZAS

S.M.	C.P.
01	202501
02	202502
03	202503
04	202504
05	202518

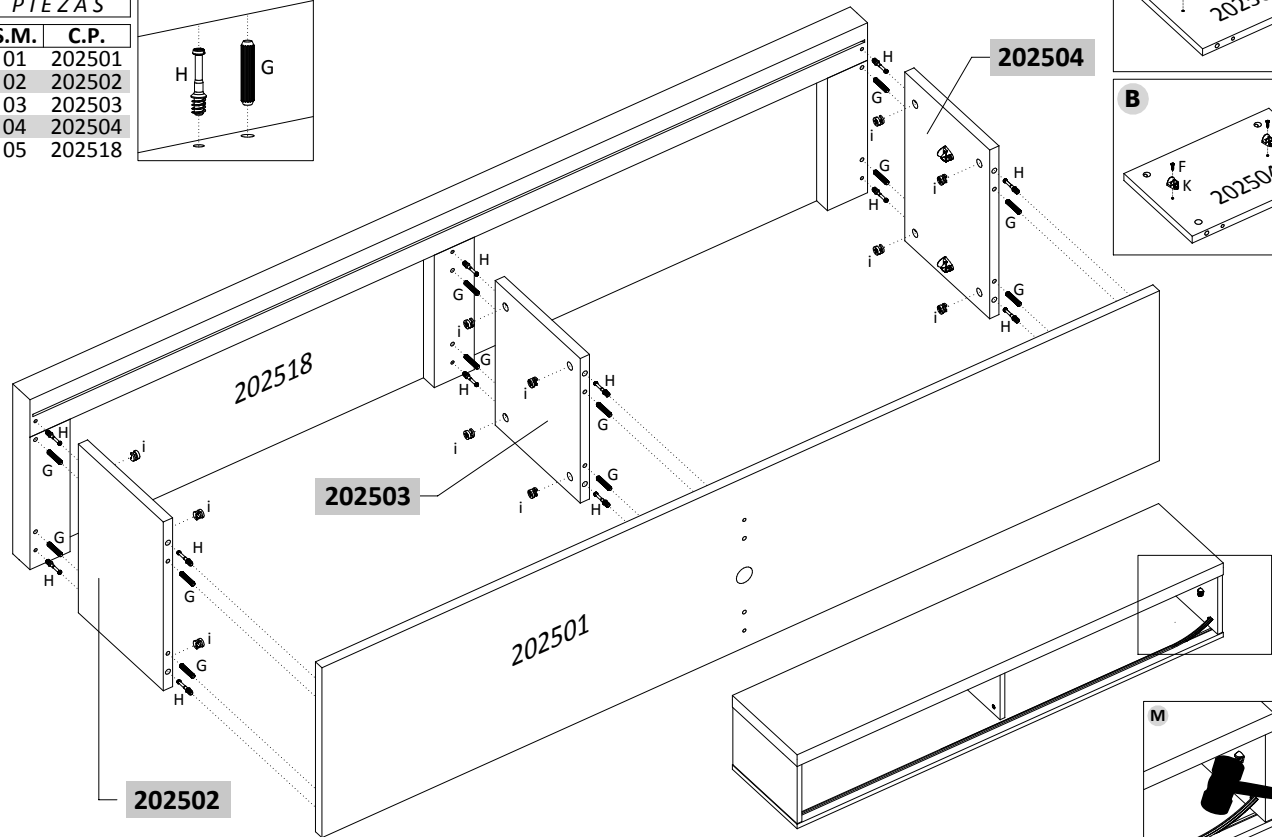
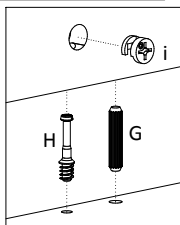

**A**

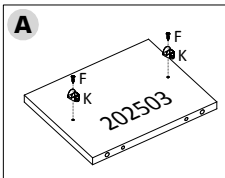

**B**

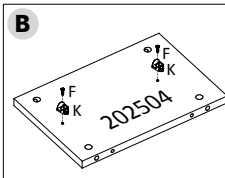

**2º PASSO | PASS | PASO**

PEÇAS  
PIECES  
PIEZAS

S.M.	C.P.
01	202510
02	202512
03	202511
04	202513
05	202511
06	202513
07	202512
08	202510

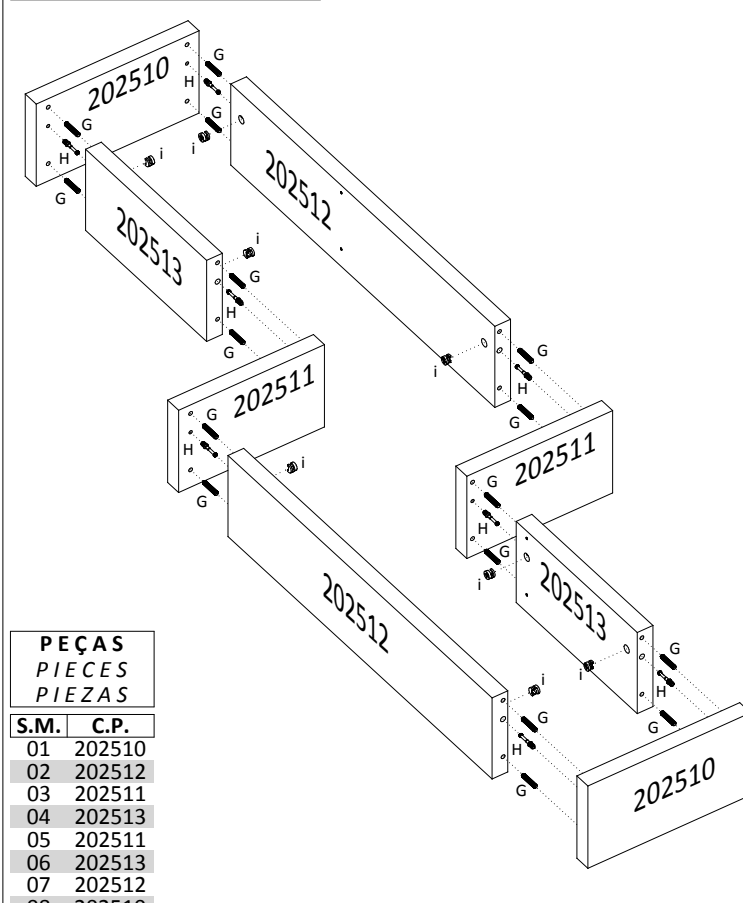

**3º PASSO | PASS | PASO**

PEÇAS  
PIECES  
PIEZAS

S.M.	C.P.
01	202505
02	202506
03	202506
04	202506

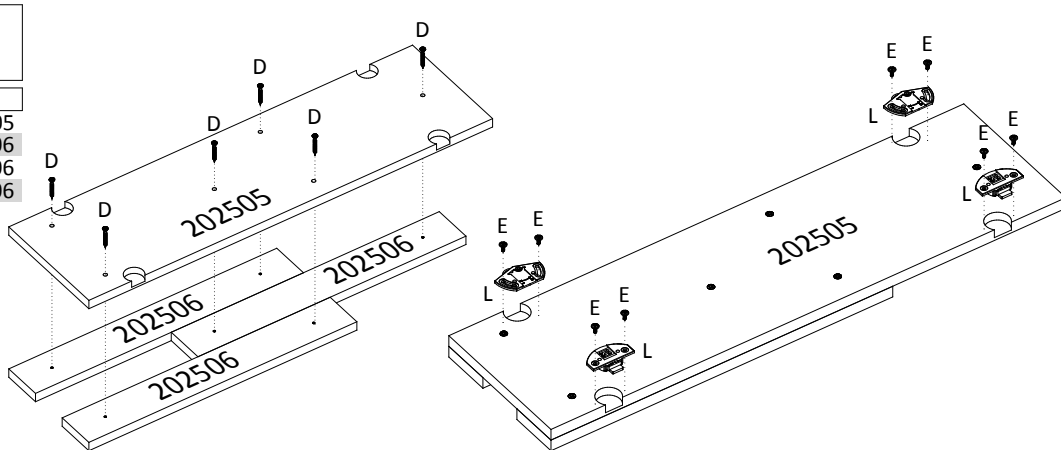

**4º PASSO | PASS | PASO**

PEÇAS  
PIECES  
PIEZAS

S.M.	C.P.
01	202508
02	202515
03	202507

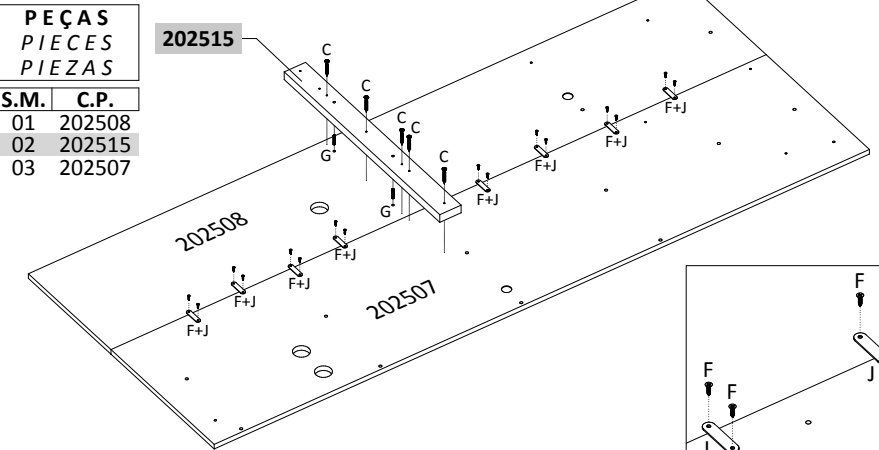

5º PASSO | PASS | PASO

PEÇAS  
PIECES  
PIEZAS

S.M.	C.P.
01	202508
02	202515

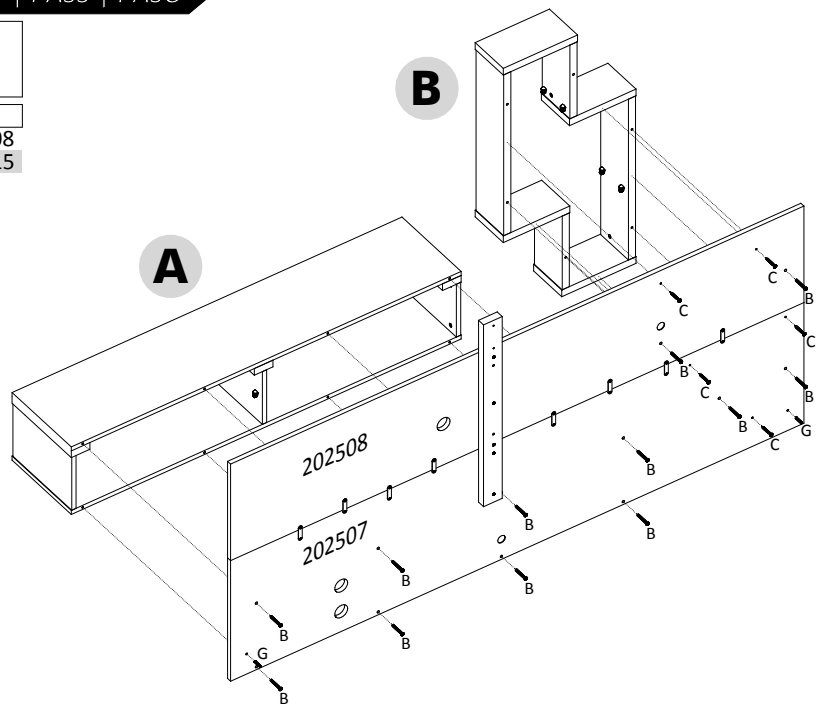

6º PASSO | PASS | PASO

PEÇAS  
PIECES  
PIEZAS

S.M.	C.P.
01	202509
02	202516
03	202514
04	202514

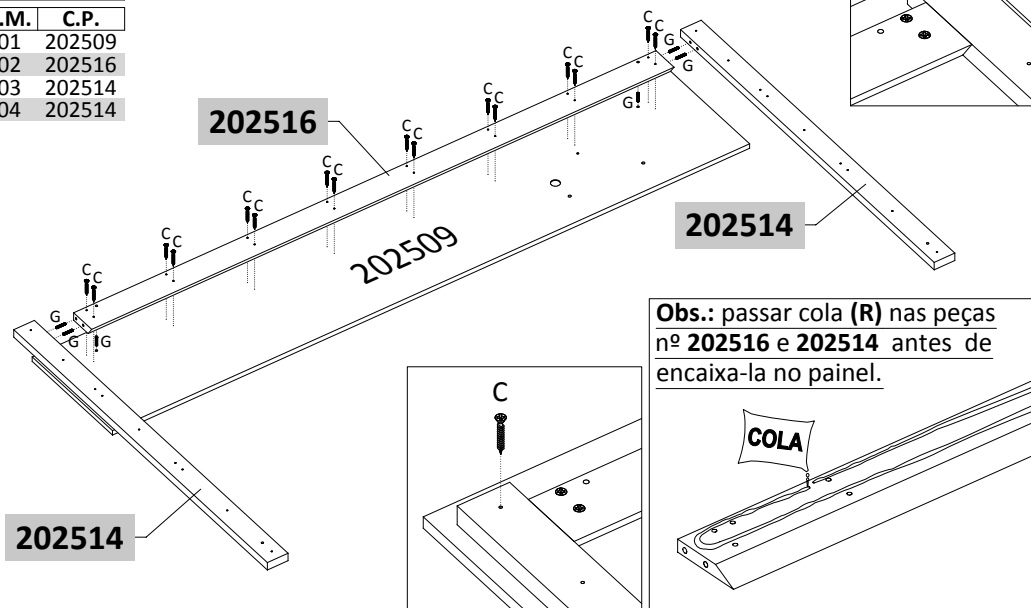

Obs.: passar cola (R) nas peças nº 202516 e 202514 antes de encaixa-la no painel.

COLA

7º PASSO | PASS | PASO

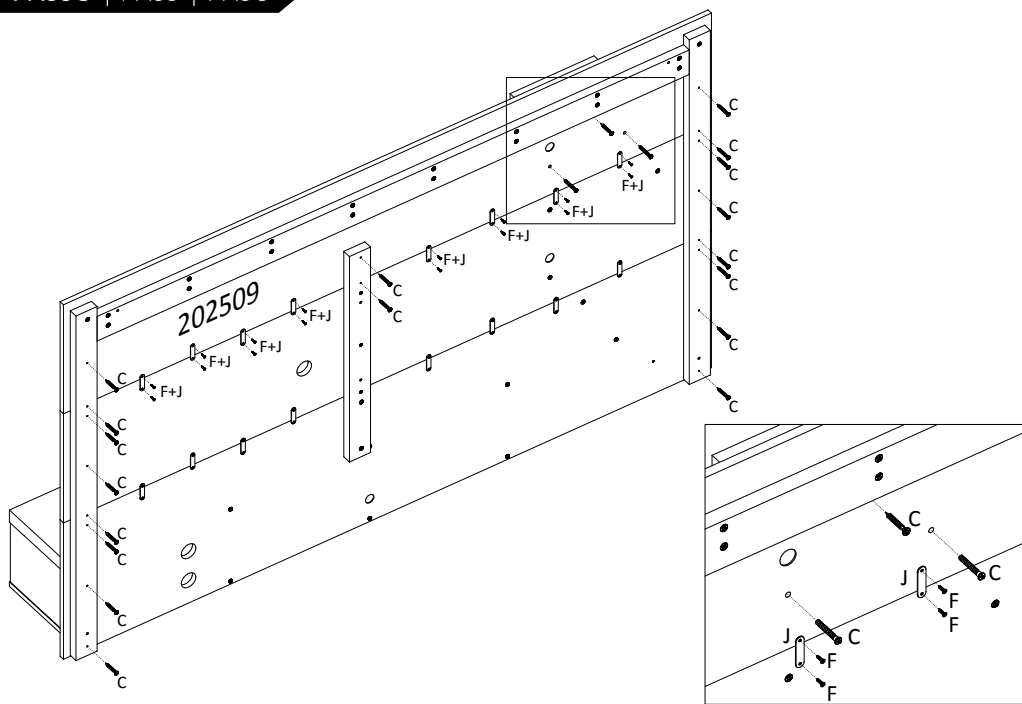

8º PASSO | PASS | PASO

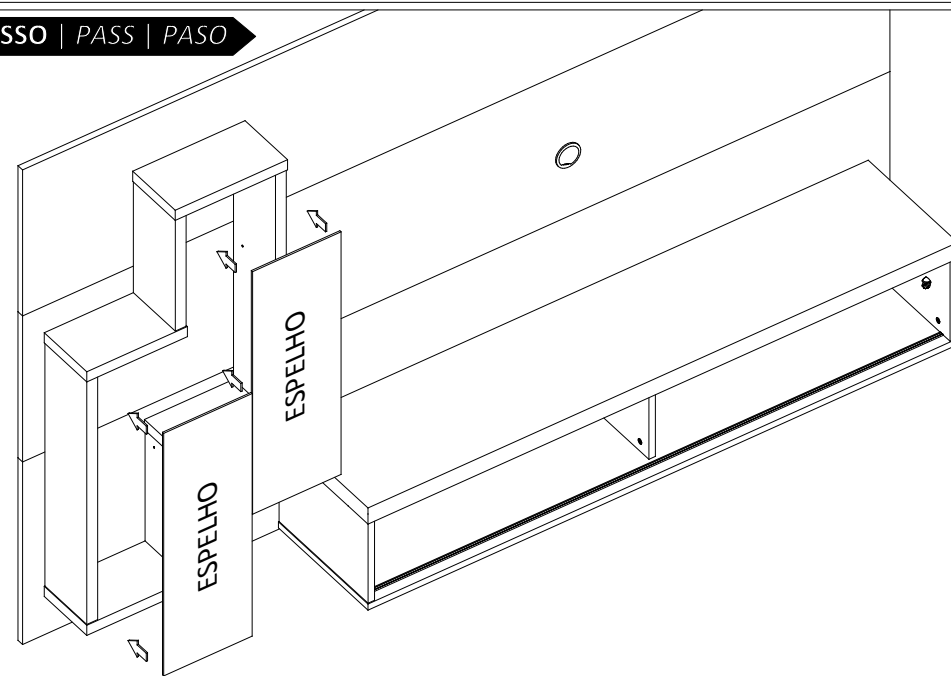

Colar espelhos com fita dupla face | Mirrors necklace with double sided tape | Fijar los espejos con cinta de doble cara

9º PASSO | PASS | PASO

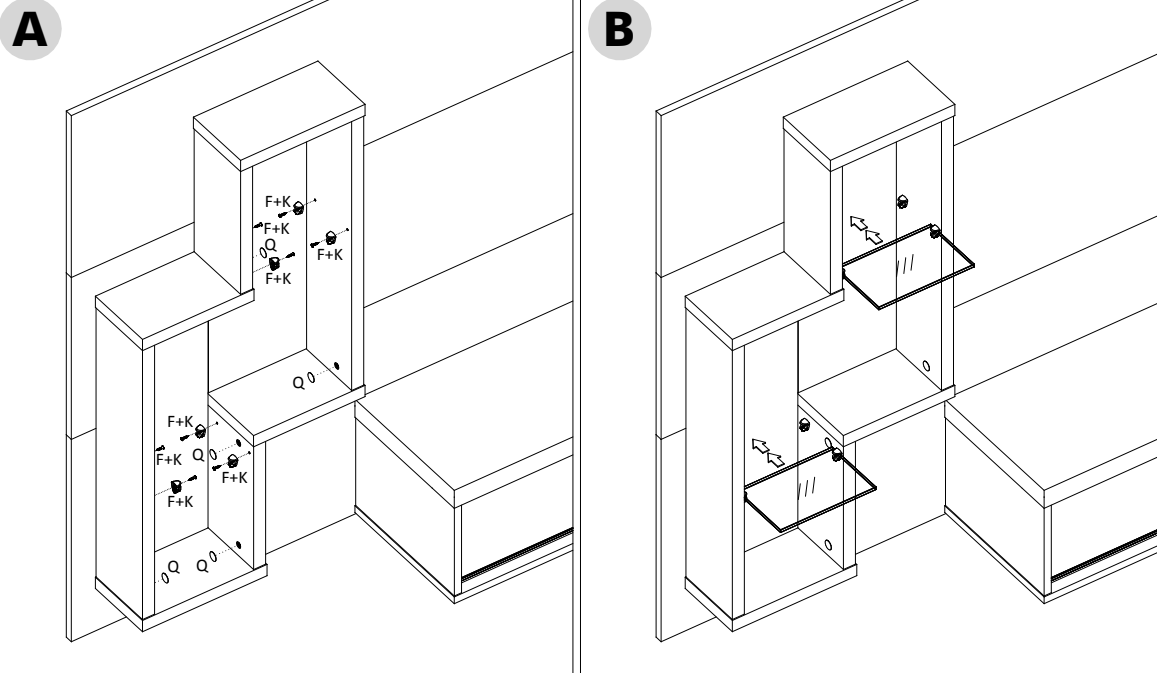

10º PASSO | PASS | PASO

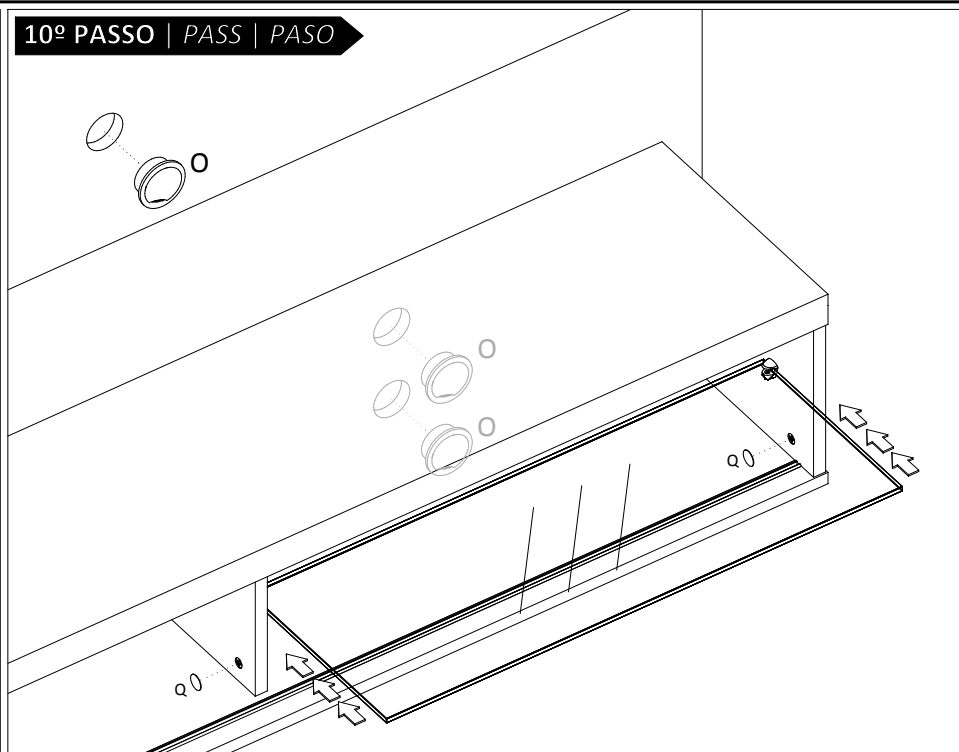

11º PASSO | PASS | PASO

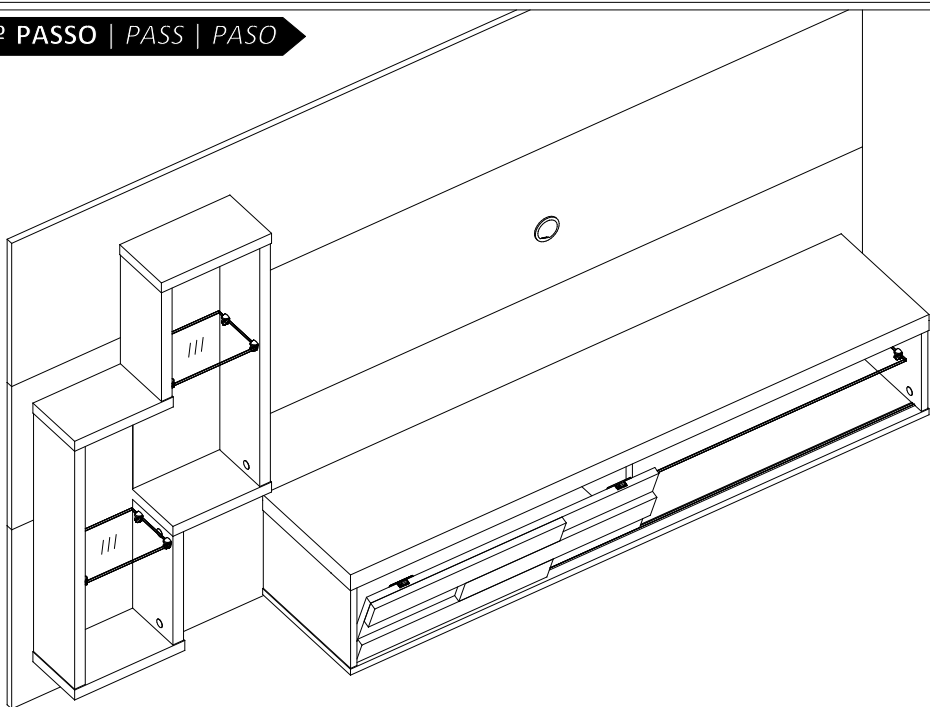

12º PASSO | PASS | PASO

