

## 4501A Esquema

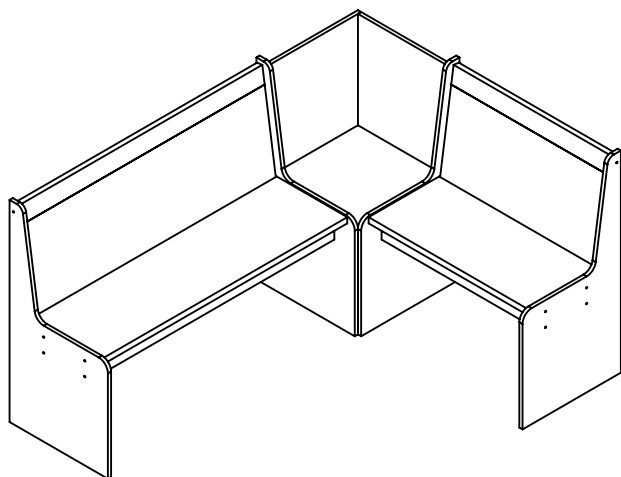

DIMENSÕES: (mm)

1630x900x1230

(LARG. x ALTURA x PROF.)

Os painéis traseiros (costas) fixam a estrutura. Assegure-se de que a estrutura tenha ângulos retos (90°), antes de pregar os painéis. Pelo contrário o móvel não ficará firme.

**ENGLISH:** The BACK Panels are responsible for holding the frame. This is the reason the structure must be assembled at right angles (90°) BEFORE nailing the back panel in place.

**ESPAÑOL:** Los paneles traseros fijan la estructura. Asegúrate de que la estructura tenga ángulos rectos (90 grados) ANTES de colocar los clavos del panel. De lo contrario el mueble quedará inclinado.

**FRANÇAISE:** C'est le dos qui maintient la structure. Il est donc important que la structure soit d'aplomb (angles à 90 degrés) avant de commencer à clouer le dos. Dans le cas contraire, le meuble ne sera pas stable.

Ferramentas usadas para montagem:

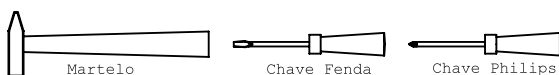

Parabéns pela aquisição de um produto de qualidade, presente em mais de 60 países, nos 5 continentes. Antes de iniciar a montagem confira todos os componentes com a lista de peças ao lado. Em caso de dúvidas procure a loja em que efetuou a compra. Observe atentamente as instruções e siga rigorosamente as etapas de montagem. Com o uso não esqueça de apertar os parafusos periodicamente.

**ENGLISH:** Congratulations for your purchase. This is a fine-quality product sold in over sixty countries. Please check all components before assembly. Follow the assembly instructions carefully. Be sure to regularly tighten the screws.

**ESPAÑOL:** Felicitaciones! Usted acaba de adquirir un producto de alta calidad, presente en más de sesenta países en los cinco continentes. Antes de empezar el armado, asegúrese de que estén todos los componentes de la Lista. Si tiene dudas, dirijase a la tienda en que hizo la compra. Observe atentamente las instrucciones y siga rigurosamente las etapas del montaje. Ajuste los tornillos regularmente.

**FRANÇAISE:** Nos félicitations pour l'achat d'un produit haut de gamme, présent dans plus d'une soixante de pays dans les cinq continents. Avant de commencer le montage, vérifiez tous les composants à l'aide de la liste de pièces. En cas de doute, cherchez le magasin ou vous avez fait l'acquisition. Observez les instructions avec attention et suivez soigneusement chaque étape du montage. Avec l'usage, n'oubliez pas de resserrer les vis de temps en temps.

### Cuidados com o móvel:

Com o intuito de garantir a sua satisfação e confirmar o nosso compromisso com a qualidade, queremos que o Senhor(a), leia atentamente nossas recomendações para com o cuidado de seu móvel.

1. Proteja-o da incidência direta da luz solar.
2. Evite colocá-lo próximo de estufas ou saídas de ar condicionado.
3. Não deixe em lugar úmido e não o exponha às intempéries.
4. Evite objetos pontiagudos sobre a sua superfície.
5. Para movimentar o móvel de lugar, carregue-o, não empurre-o nem arraste-o.
6. Mantenha o móvel sempre nivelado para garantir o bom funcionamento das portas e gavetas.
7. Fixe as costas observando bem o esquadro e colocando a quantidade correta de pregos.
8. Não fique de pé sobre os assentos das cadeiras.
9. Não incline-se para trás balançando as cadeiras sobre as pernas traseiras.
10. Evite utilizar as travessas das cadeiras como apoio dos pés.

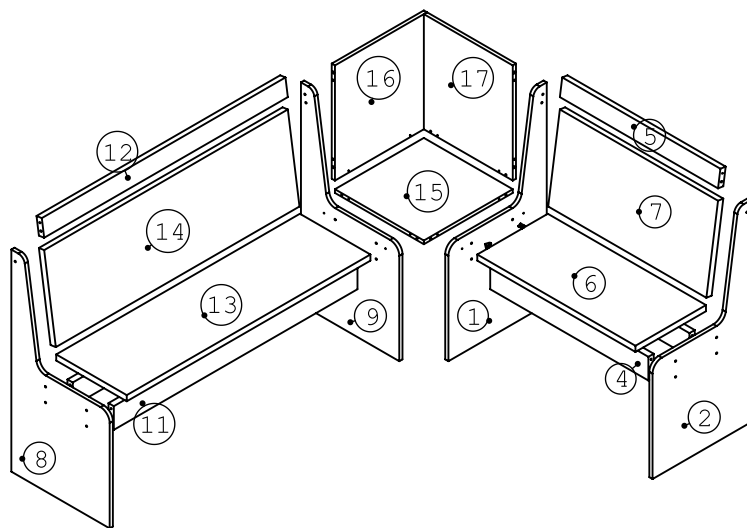

IT	DESCRIÇÃO	DIMENSÃO	MAT	QT
1	4501.01 LATERAL ESQ 01	15x460x900	MDP	1
2	4501.02 LATERAL DIR 01	15x460x900	MDP	1
3	4501.03 TRAVESSA TRAS 01	25x96x740	MDP	1
4	4501.04 TRAVESSA FRON 01	25x96x740	MDP	1
5	4501.05 TRAVESSA SUP ENC 01	25x75x740	MDF	1
6	4501.06 ASSENTO 01	15x330x740	MDP	1
7	4501.07 ENCOSTO 01	15x370x740	MDP	1
8	4501.11 LATERAL ESQ 02	15x460x900	MDP	1
9	4501.12 LATERAL DIR 02	15x460x900	MDP	1
10	4501.13 TRAVESSA TRAS 02	25x96x1140	MDP	1
11	4501.14 TRAVESSA FRON 02	25x96x1140	MDP	1
12	4501.15 TRAVESSA SUP ENC 02	25x75x1140	MDF	1
13	4501.16 ASSENTO 02	15x330x1140	MDP	1
14	4501.17 ENCOSTO 02	15x370x1140	MDP	1
15	4501.21 ASSENTO CANTO	15x416x416	MDP	1
16	4501.23 FECHAMENTO 01	15x431x466	MDP	1
17	4501.24 FECHAMENTO 02	15x416x466	MDP	1

# 4501A Esquema

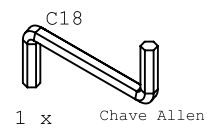
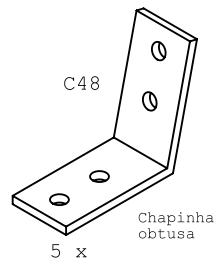
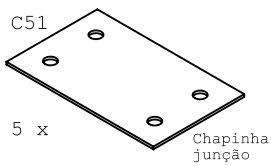
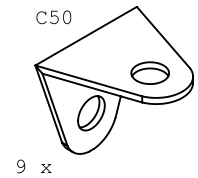
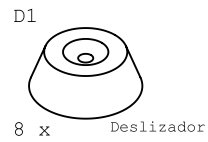
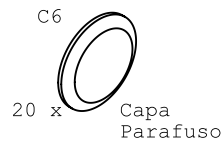
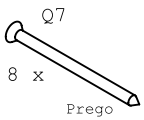
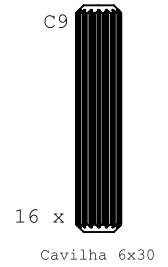
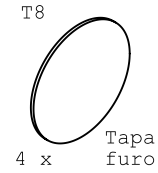
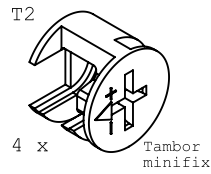
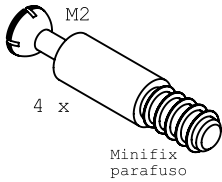
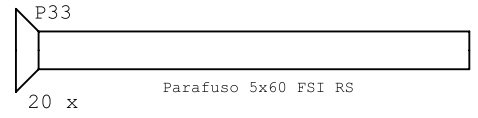
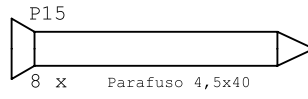
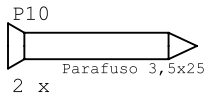
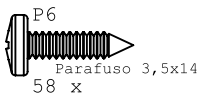

# 4501A Esquema

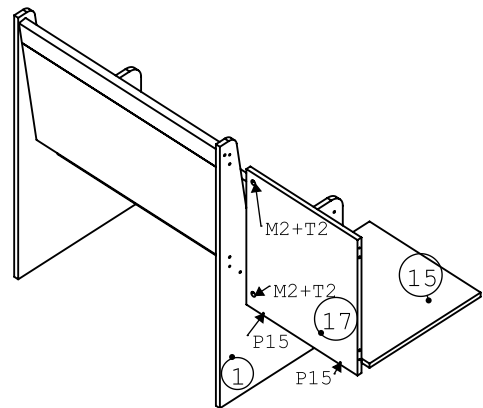
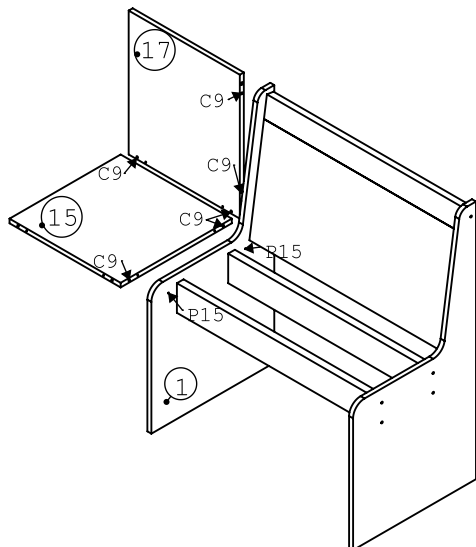
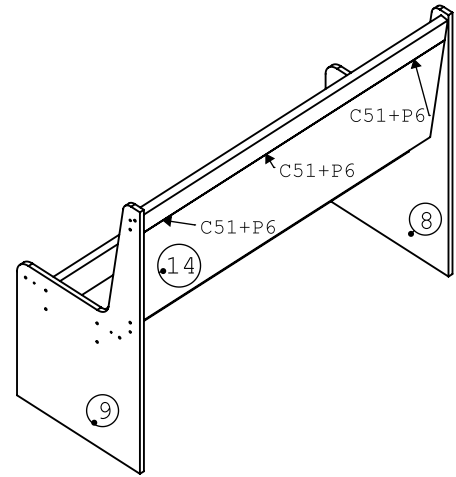
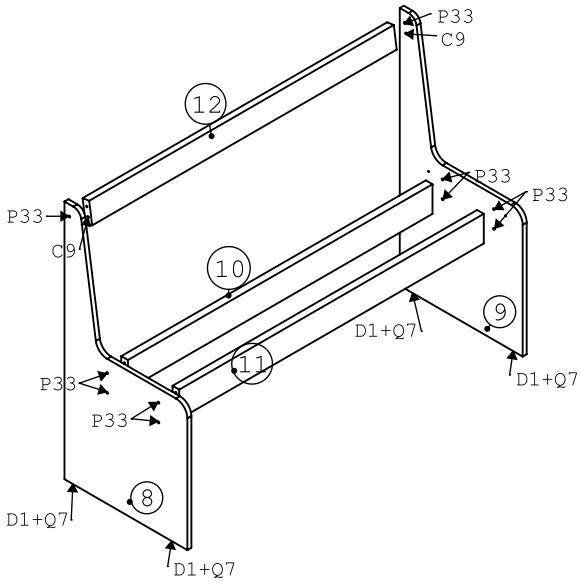
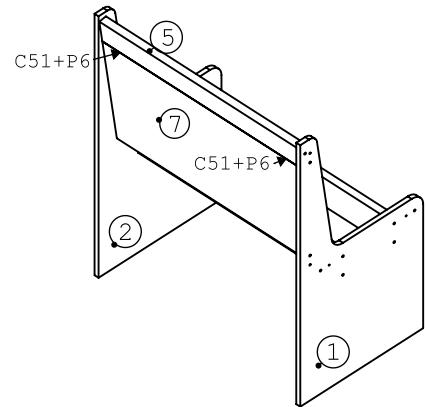
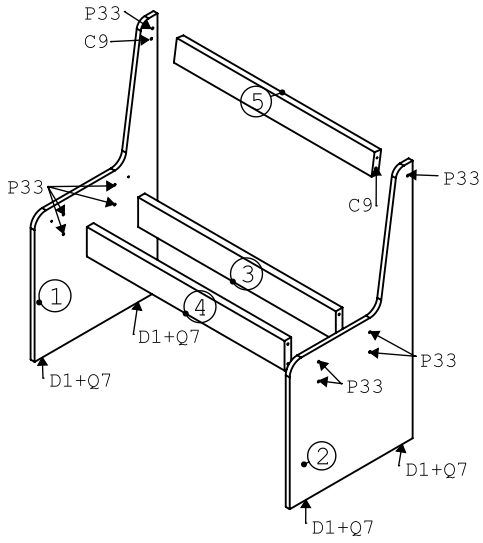

4501A Esquema

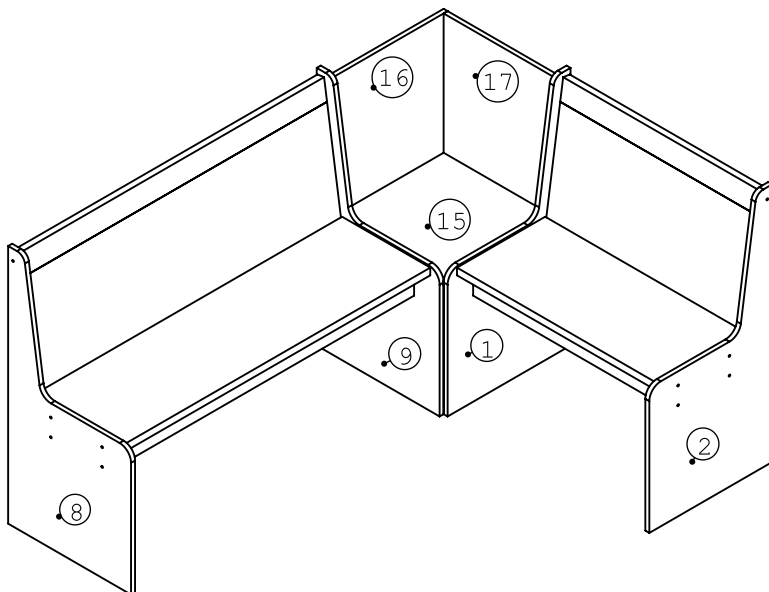
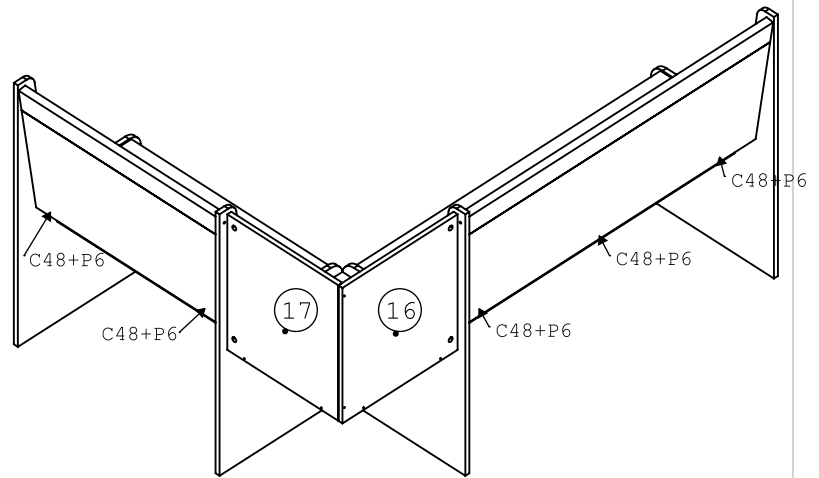
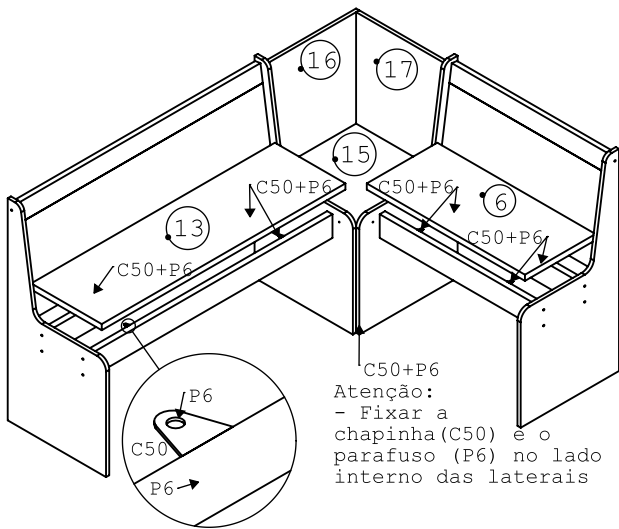
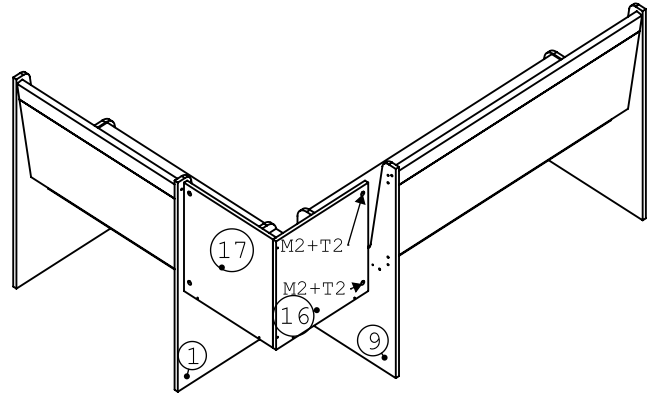
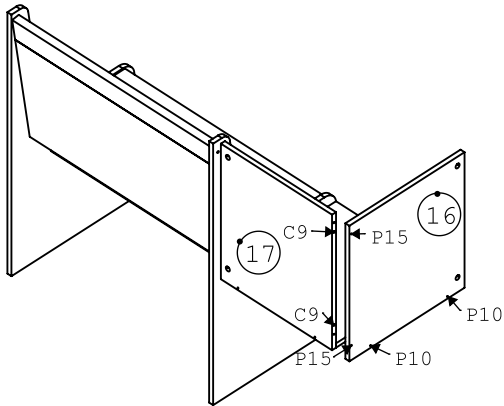

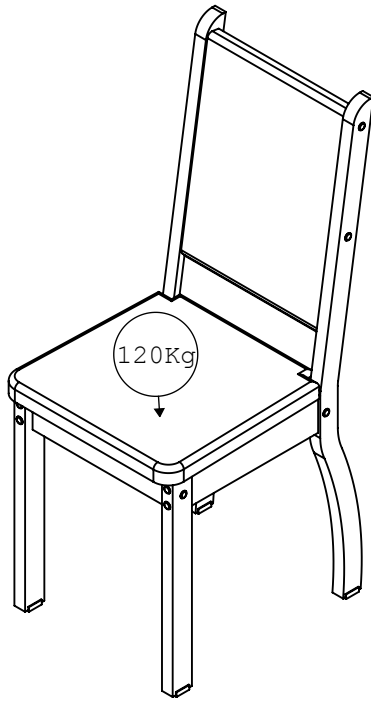

DIMENSÕES: (mm)

405x980x510

(LARG. x ALTURA x PROF.)

Os painéis traseiros (costas) fixam a estrutura. Assegure-se de que a estrutura tenha ângulos retos (90°), antes de pregar os painéis. Pelo contrário o móvel não ficará firme.

**ENGLISH:** The BACK Panels are responsible for holding the frame. This is the reason the structure must be assembled at right angles (90°) BEFORE nailing the back panel in place.

**ESPAÑOL:** Los paneles traseros fijan la estructura. Asegúrate de que la estructura tenga ángulos rectos (90 grados) ANTES de colocar los clavos del panel. De lo contrario el mueble quedará inclinado.

Parabéns pela aquisição de um produto de qualidade, presente em mais de 60 países, nos 5 continentes. Antes de iniciar a montagem confira todos os componentes com a lista de peças ao lado. Em caso de dúvidas procure a loja em que efetuou a compra. Observe atentamente as instruções e siga rigorosamente as etapas de montagem. Com o uso não esqueça de apertar os parafusos periodicamente.

**ENGLISH:** Congratulations for your purchase. This is a fine-quality product sold in over sixty countries. Please check all components before assembly. Follow the assembly instructions carefully. Be sure to regularly tighten the screws.

**ESPAÑOL:** Felicitaciones! Usted acaba de adquirir un producto de alta calidad, presente en más de sesenta países en los cinco continentes. Antes de empezar el armado, egúrese de que estén todos los componentes de la Lista. Si tiene dudas, dirijase a la tienda en que hizo la compra. Observe atentamente las instrucciones y siga rigurosamente las etapas del montaje. Ajuste los tornillos regularmente.

**Cuidados com o móvel:**

Com o intuito de garantir a sua satisfação e confirmar o nosso compromisso com a qualidade, queremos que o Senhor(a), leia atentamente nossas recomendações para com o cuidado de seu móvel.

1. Proteja-o da incidência direta da luz solar.
2. Evite colocá-lo próximo de estufas ou saídas de ar condicionado.
3. Não deixe em lugar úmido e não o exponha às intempéries.
4. Evite objetos pontiagudos sobre a sua superfície.
5. Para movimentar o móvel de lugar, carregue-o, não empurre-o nem arraste-o.
6. Mantenha o móvel sempre nivelado para garantir o bom funcionamento das portas e gavetas.
7. Fixe as costas observando bem o esquadro e colocando a quantidade correta de pregos.
8. Não fique de pé sobre os assentos das cadeiras.
9. Não incline-se para trás balançando as cadeiras sobre as pernas traseiras.
10. Evite utilizar as travessas das cadeiras como apoio dos pés.

**Certificado de Garantia:**

Será de **90 dias** o prazo para defeitos aparentes e de fácil constatação, contados da data de instalação. Será de **três (03)** meses a garantia do móvel por defeitos de fabricação, ressalvadas condições normais de uso e as demais condições do presente certificado, contados da data da emissão da nota fiscal.

Rustic	Tabaco	IT	DESCRIÇÃO	DIMENSÃO	MAT	QT
203342385Z19	203342381419	1	4238.19 PE TRAS ESQ	25x41x980	MDF	1
203342385Z11	203342381411	2	4238.11 PE TRAS DIR	25x41x980	MDF	1
203341735Z12	2033417314123	3	4238.12 PE FRONTAL	25x45x435	MDF	2
203342025Z04	203342021404	4	4238.04 TRAVESSA LAT	15x75x300	MDF	2
203342075Z02	203342071402	5	4238.03 TRAVESSA FR. TRAS	15x75x320	MDF	1
		6	4238.01 ASSENTO	35x387x396	MDP	1
203342385Z09	203342381409	7	4238.06 TRAVESSA TRAS	15x171x320	MDF	1
		8	4238.07 ENCOSTO	15x320x423	MDF	1

Ferragem para uma cadeira

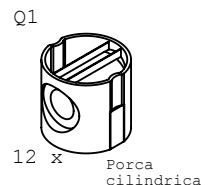
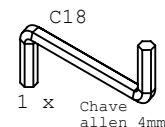
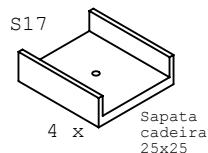
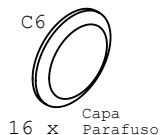
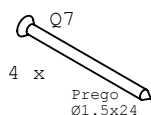
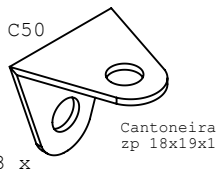
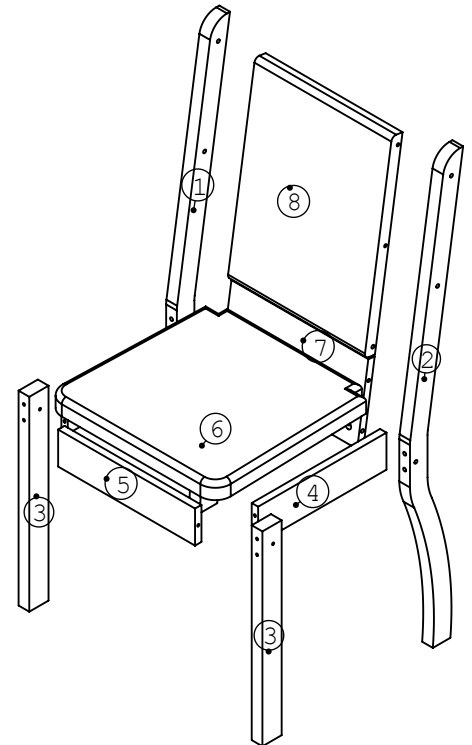
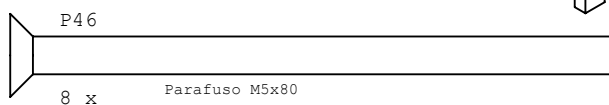
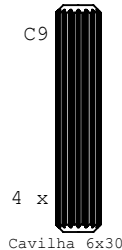
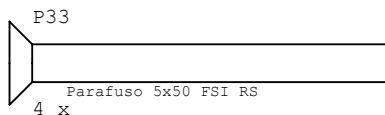
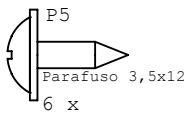

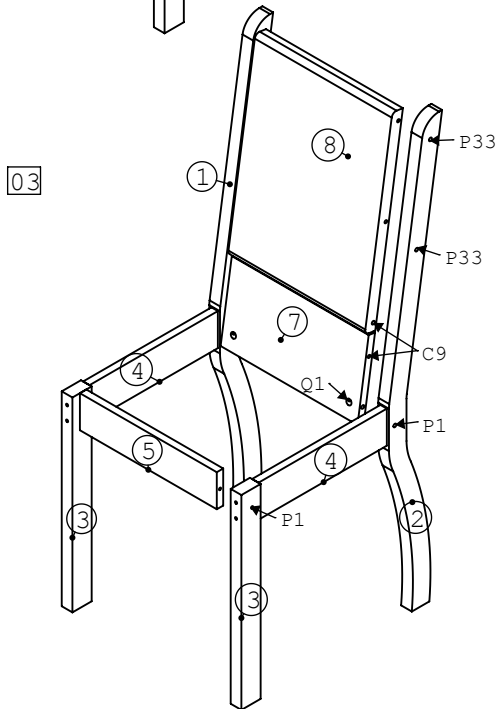
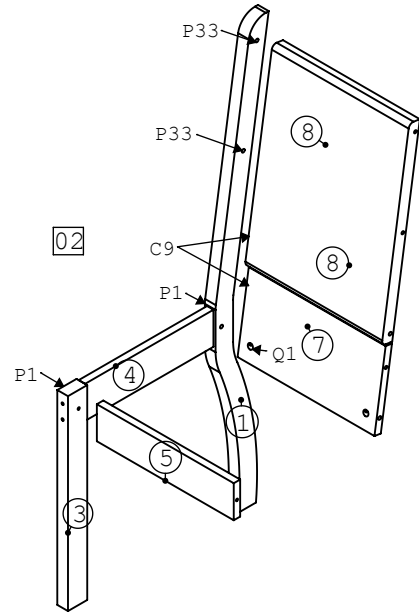
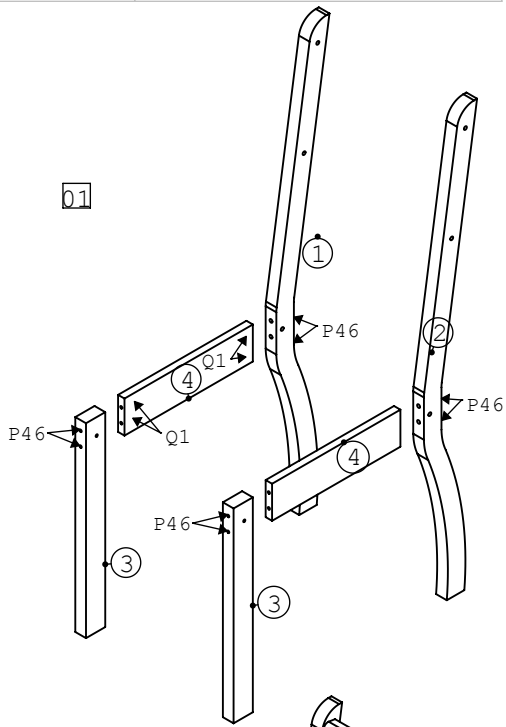

**IMPORTANTE:**  
- Antes de fixar o assento certifique-se que o mesmo esteja encostado no pé traseiro e no encosto inferior.

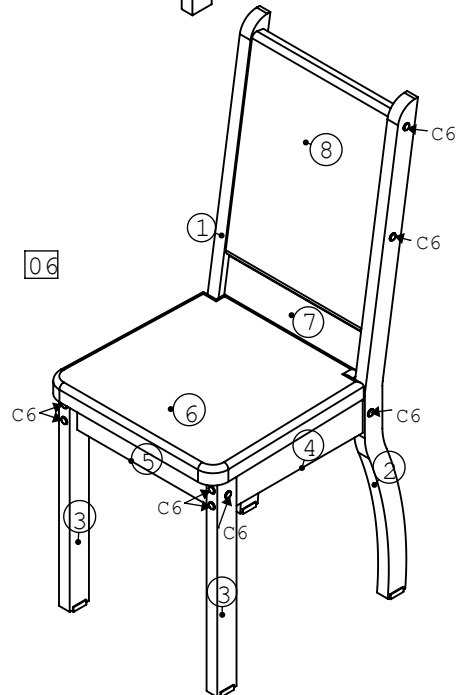
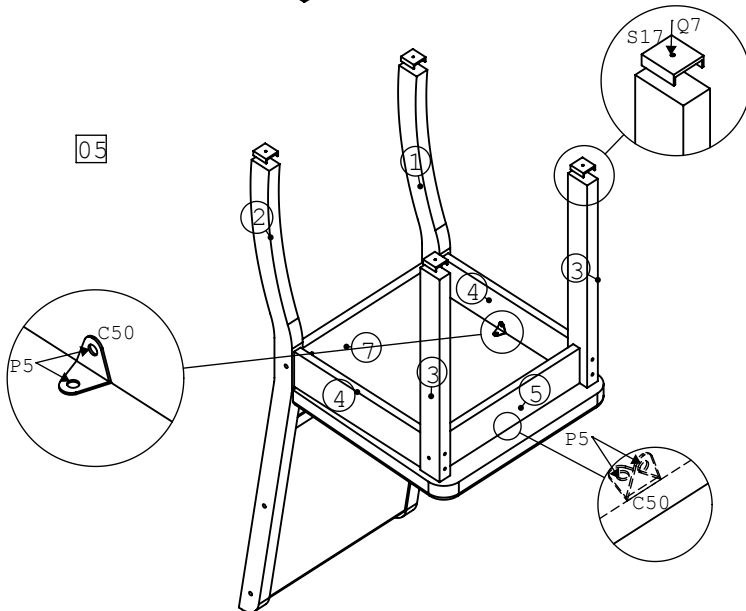
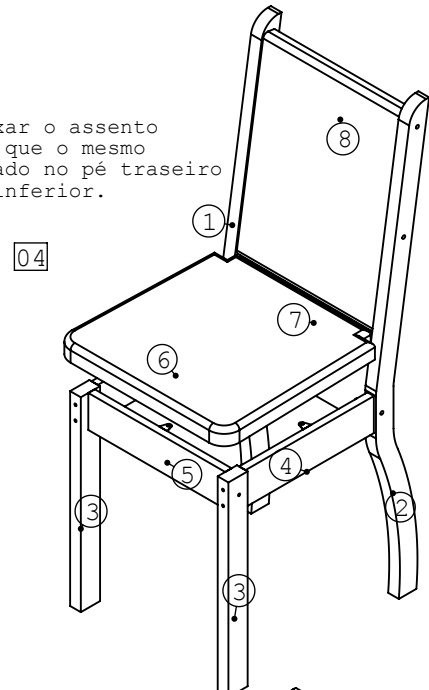

**MADERA**

**5258B**

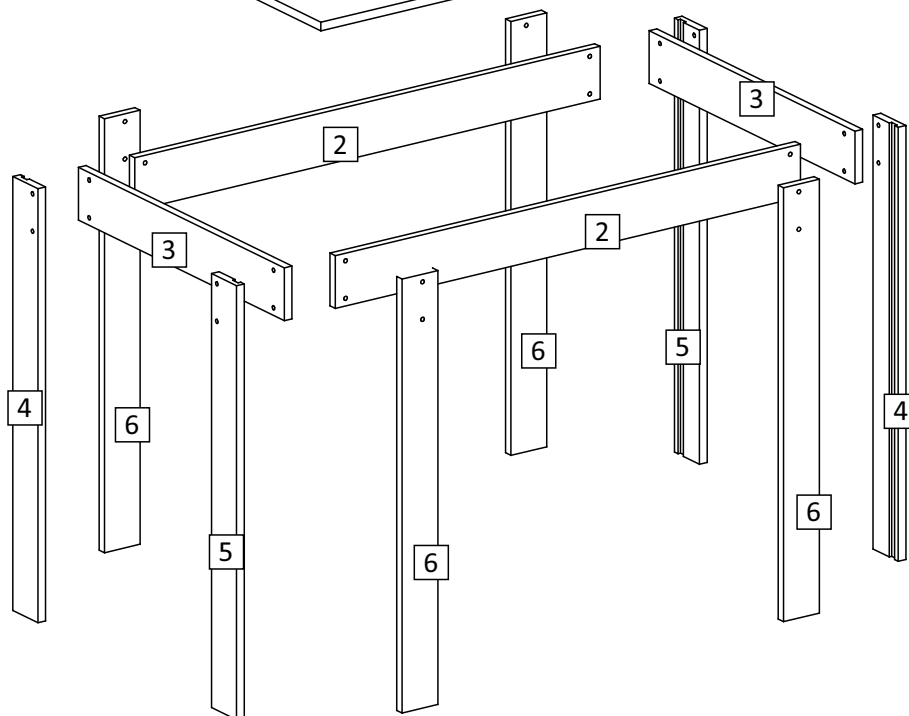
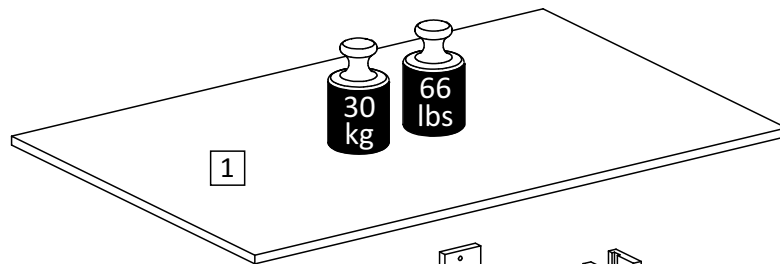
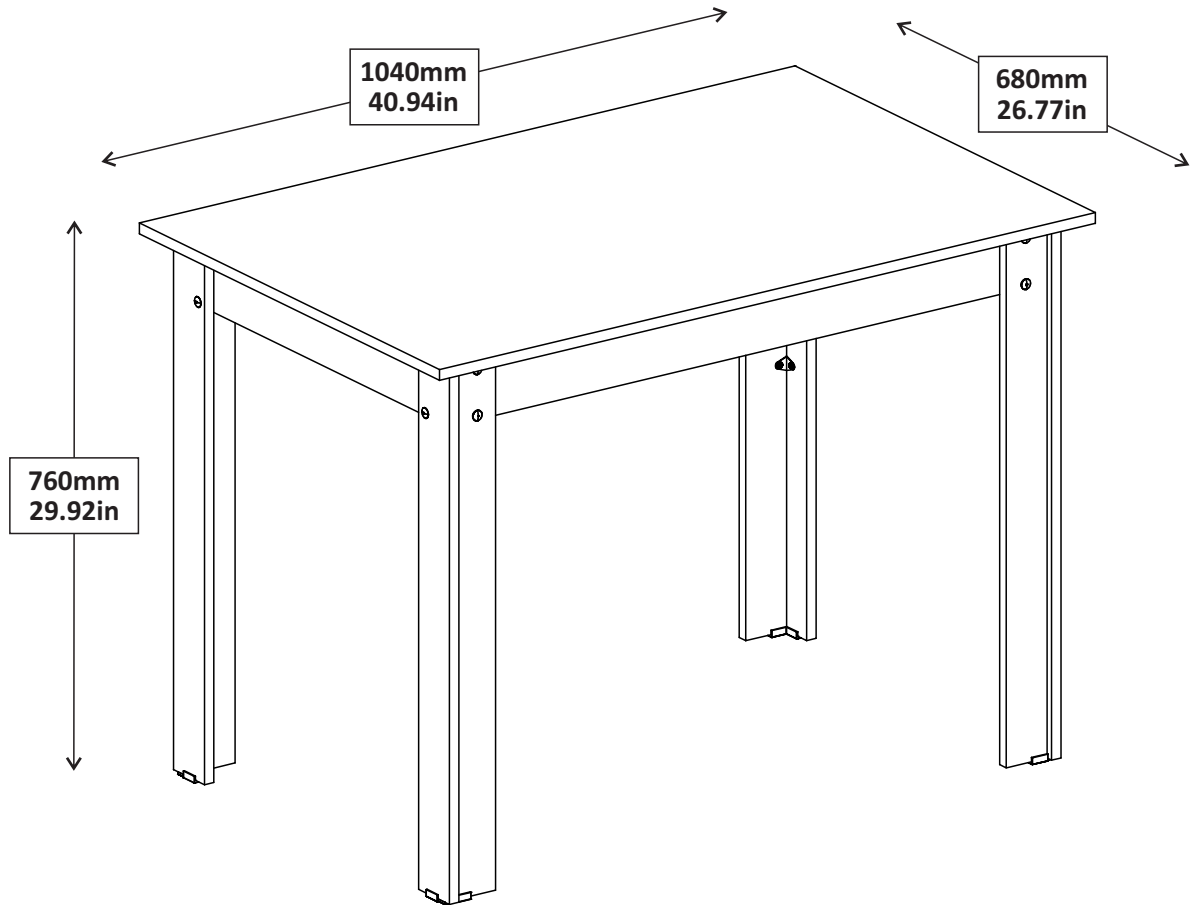

# MADESA

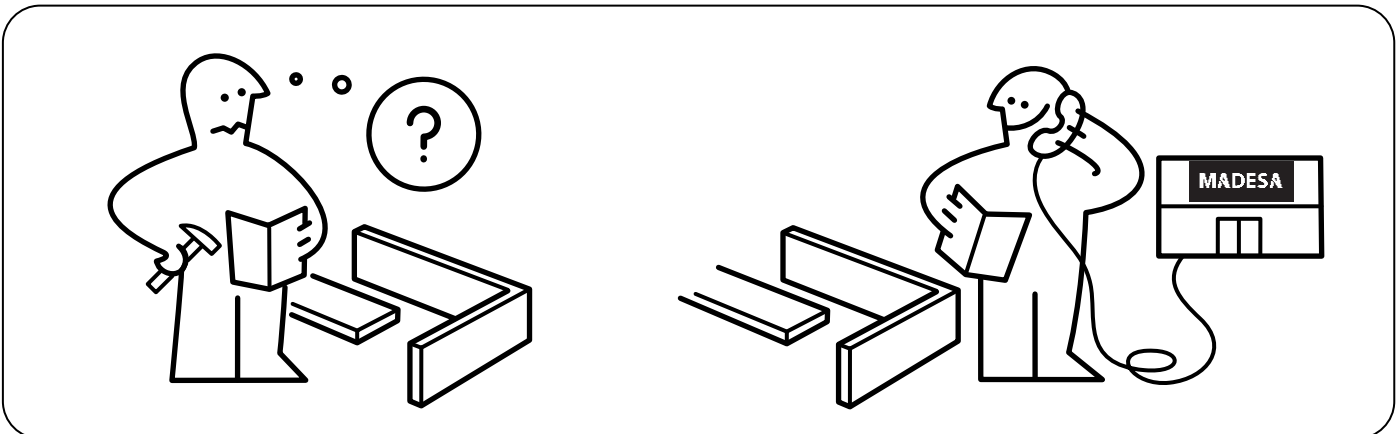
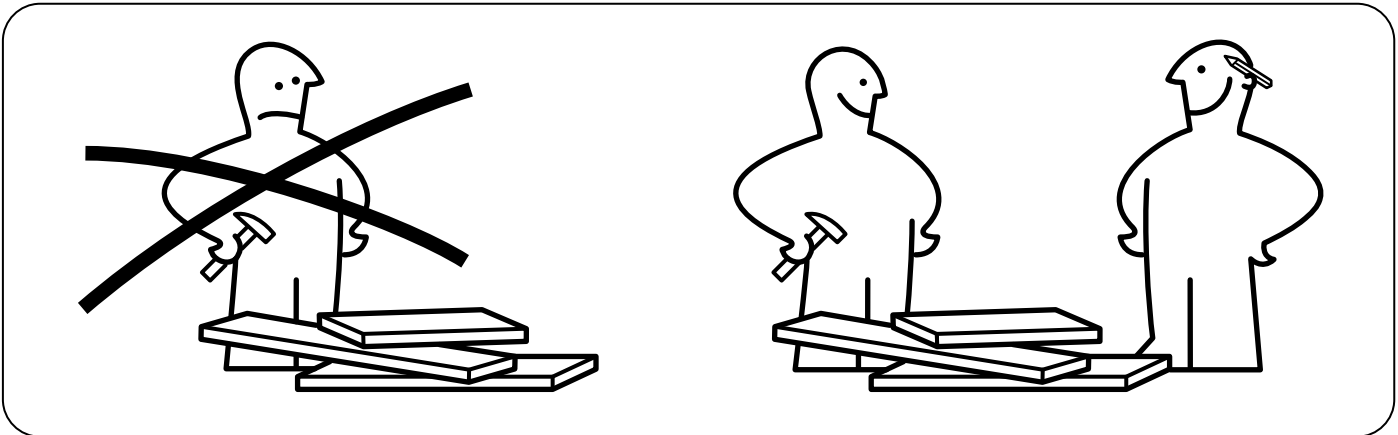
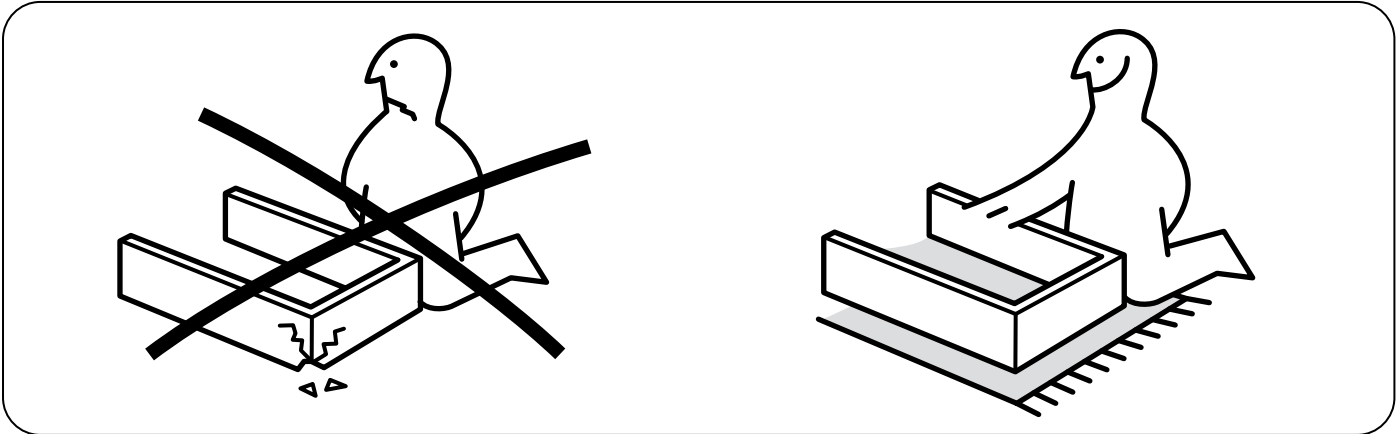
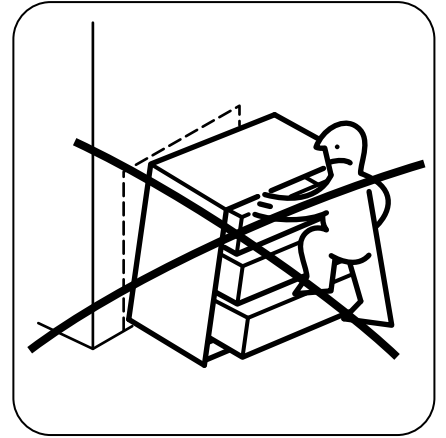
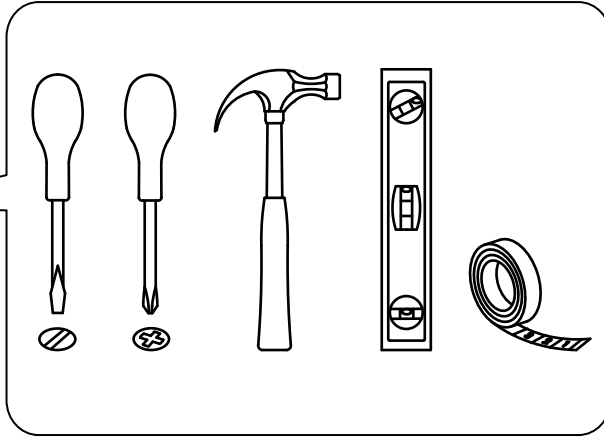
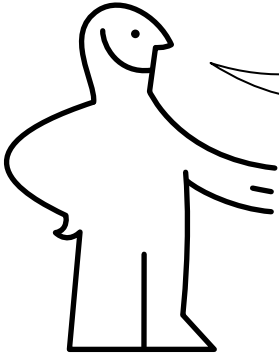



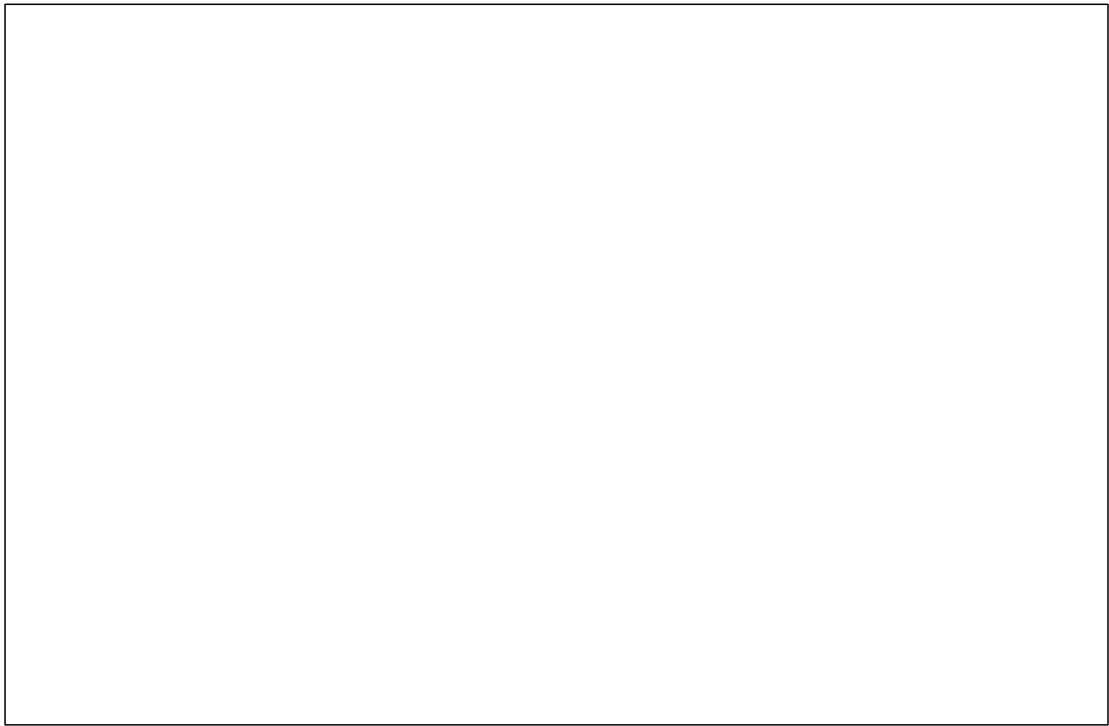

1 (15 x 680 x 1040mm)  
(0,59 x 26,77 x 40,94in)



2 (15 x 90 x 910mm) - 2x  
(0,59 x 3,54 x 35,83in)



3 (15 x 90 x 575mm) - 2x  
(0,59 x 3,54 x 22,64in)

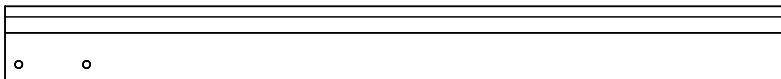

4 (15 x 70 x 740mm) - 2x  
(0,59 x 2,76 x 29,13in)

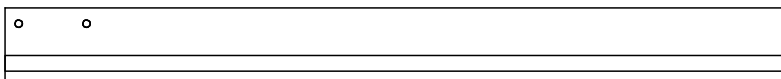

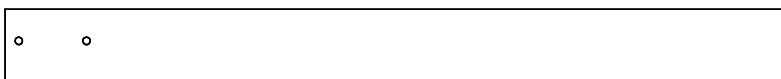

5 (15 x 70 x 740mm) - 2x  
(0,59 x 2,76 x 29,13in)

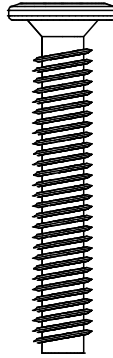
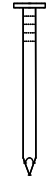
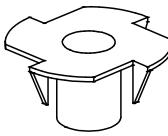
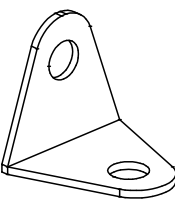

6 (15 x 70 x 740mm) - 4x  
(0,59 x 2,76 x 29,13in)

# MADESA

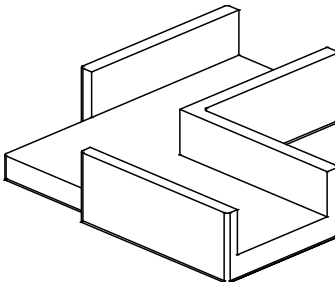
-   
**A**  
 28x
-   
**B**  
 16x
-   
**C**  
 12x
-   
**D**  
 16x
-   
**E**  
 14x
-   
**F**  
 16x
-   
**G**  
 4x

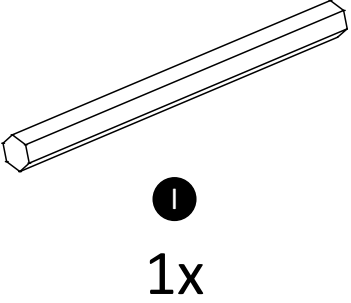
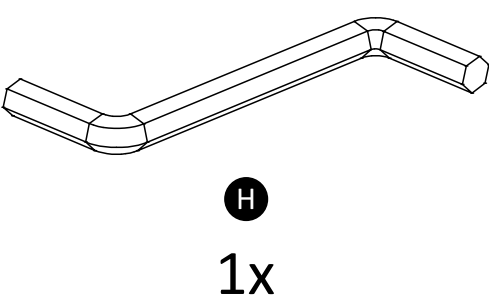

**1-2x**

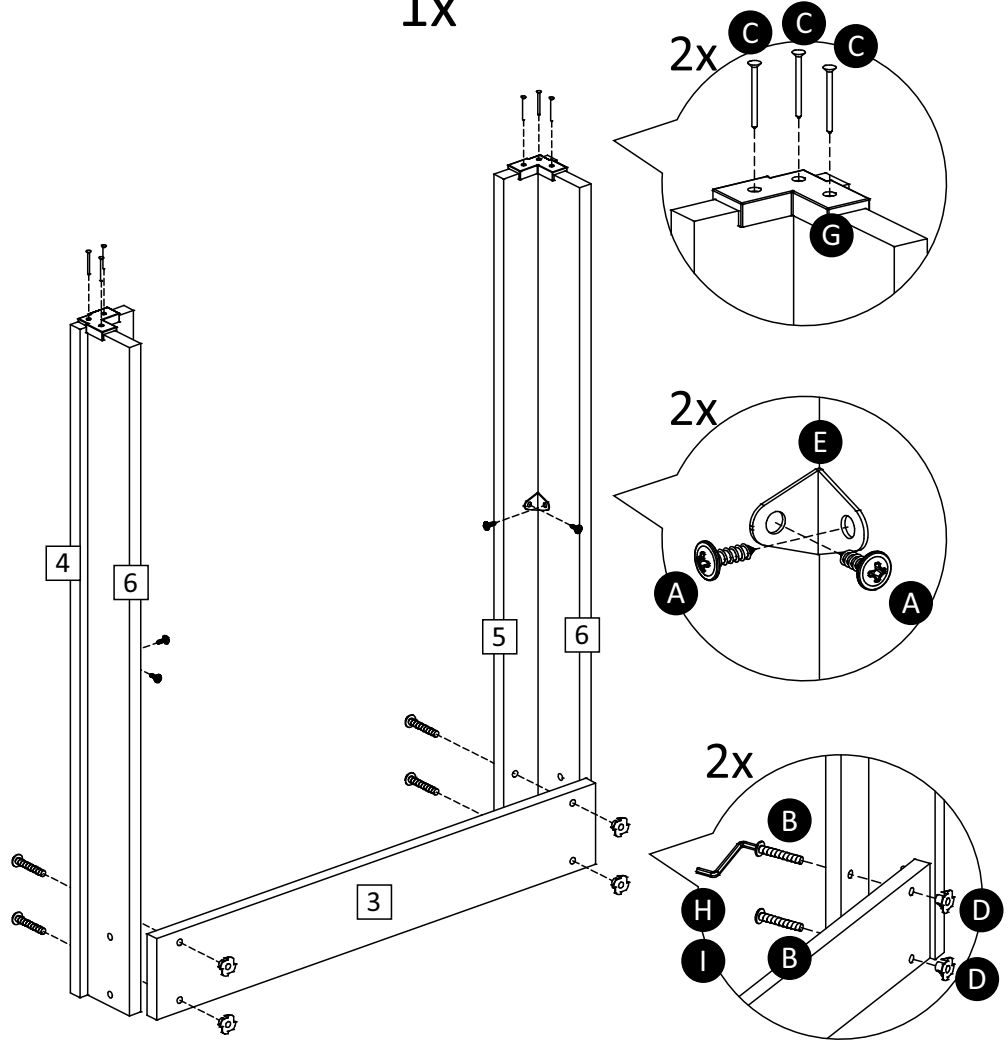

# 2

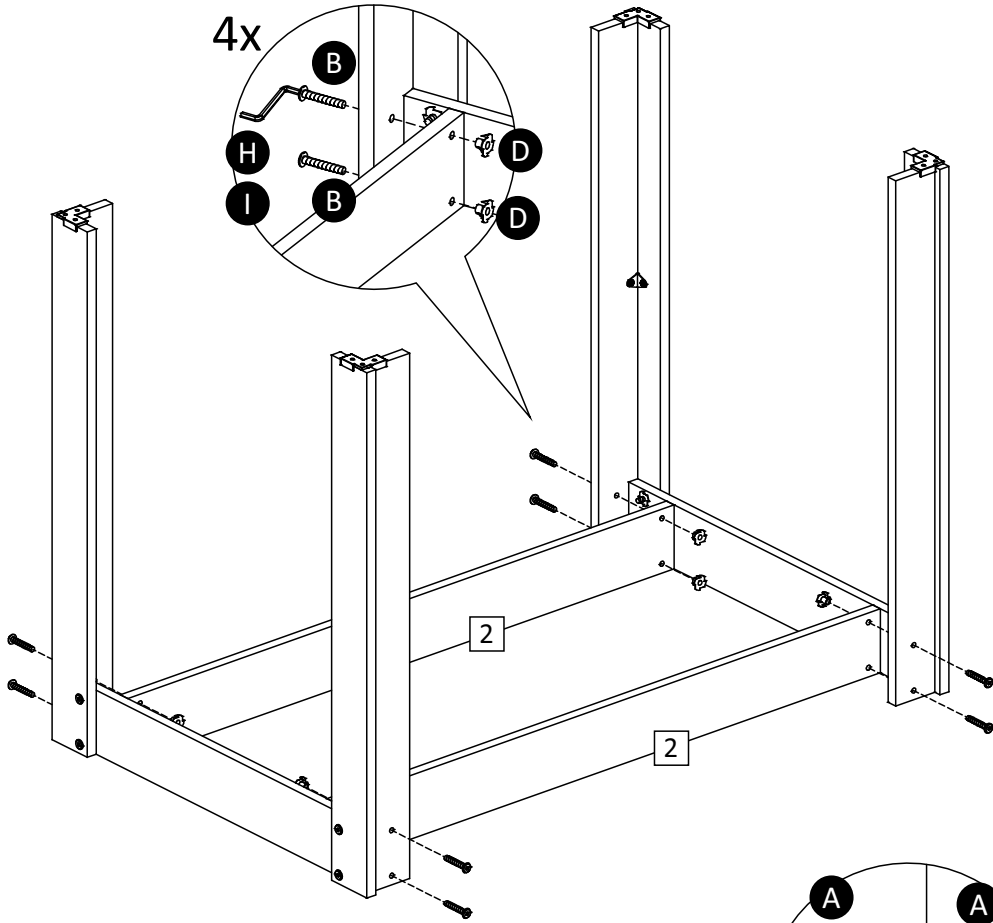

# 3

