

## Home Coliseu II

Home Coliseu II / Coliseu II Home  
Versão 1.0 / Versión 1.0 / Version 1.0

www.artely.com.br

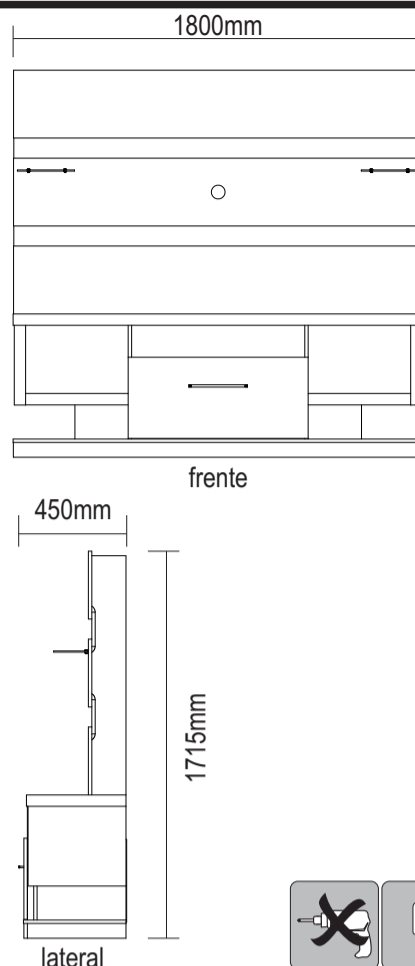

### Conservação e Limpeza

Conservación y Limpieza  
Conservation and Cleanness

Não expor o produto ao sol, altas temperaturas e umidade, não arrastar objetos sobre a superfície do móvel (ex.: TV, DVD, aparelho de som, objetos decorativos...) e mantendo-o em local seco e arejado.

Para a limpeza, utilizar um pano seco e macio. Não é necessário o uso de materiais abrasivos ou álcool.

No exponga el producto a la luz solar, las altas temperaturas y la humedad, no arrastre los objetos a través de la superficie de la unidad (por ejemplo, TV, DVD, equipo de música, objetos de decoración ...) y mantenerlo en un lugar fresco y seco.

Para la limpieza, utilizar un paño seco y suave. El uso de materiales abrasivos o del alcohol no es necesario.









Do not expose the product to sunlight, high temperatures and humidity, do not drag objects across the surface of the unit (eg TV, DVD, stereo, decorative objects ...) and keeping it in a cool dry place.

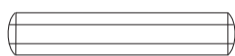

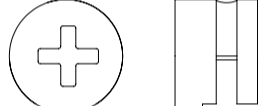

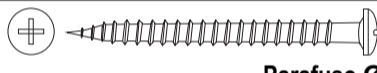

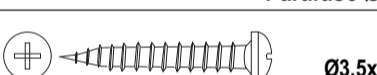
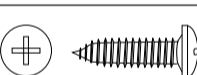

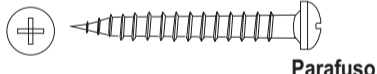
For cleaning, use a dry and soft cloth. Do not use abrasive materials or alcohol.

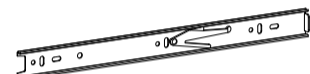
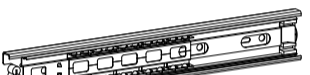

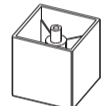
### Lista de Materiais

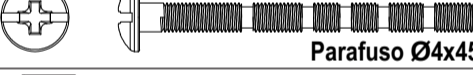
Lista de Materiales/ Hardware List

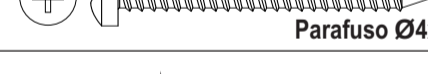
<b>A</b>		Cavilha	<b>70</b>
<b>B</b>		Minifix	<b>28</b>
<b>C</b>		Tambor	<b>28</b>
<b>D</b>		Tapa Furo Adesivo	<b>18</b>
<b>E</b>		Parafuso Ø3,5x40mm CP	<b>12</b>
<b>F</b>		Parafuso Ø3,5x12mm CC	<b>12</b>
<b>G</b>		Parafuso Ø3,5x25mm CP Preto	<b>16</b>
<b>H</b>		Parafuso Ø4,0x14mm CP	<b>16</b>
<b>I</b>		Cola	<b>2</b>
<b>J</b>		Parafuso Ø4,0x30mm CP	<b>8</b>

<b>K</b>		Corrediça Telescópica 300mm	<b>2</b>
<b>L</b>		Corrediça Telescópica 300mm	<b>2</b>
<b>M</b>		Cantoneira 1"x1"	<b>8</b>
<b>N</b>		Sapata Square	<b>4</b>
<b>O</b>		Suporte Vidro	<b>4</b>
<b>P</b>		Puxador Italy Line	<b>1</b>
<b>Q</b>		Parafuso Ø4x45mm F	<b>2</b>
<b>R</b>		Pino sustentação (Ø6x18mm)	<b>12</b>
<b>S</b>		Parafuso Ø4x45mm CP	<b>4</b>
<b>T</b>		Prego 8x8	<b>14</b>
<b>V</b>		Passa Fio Ø60mm	<b>1</b>

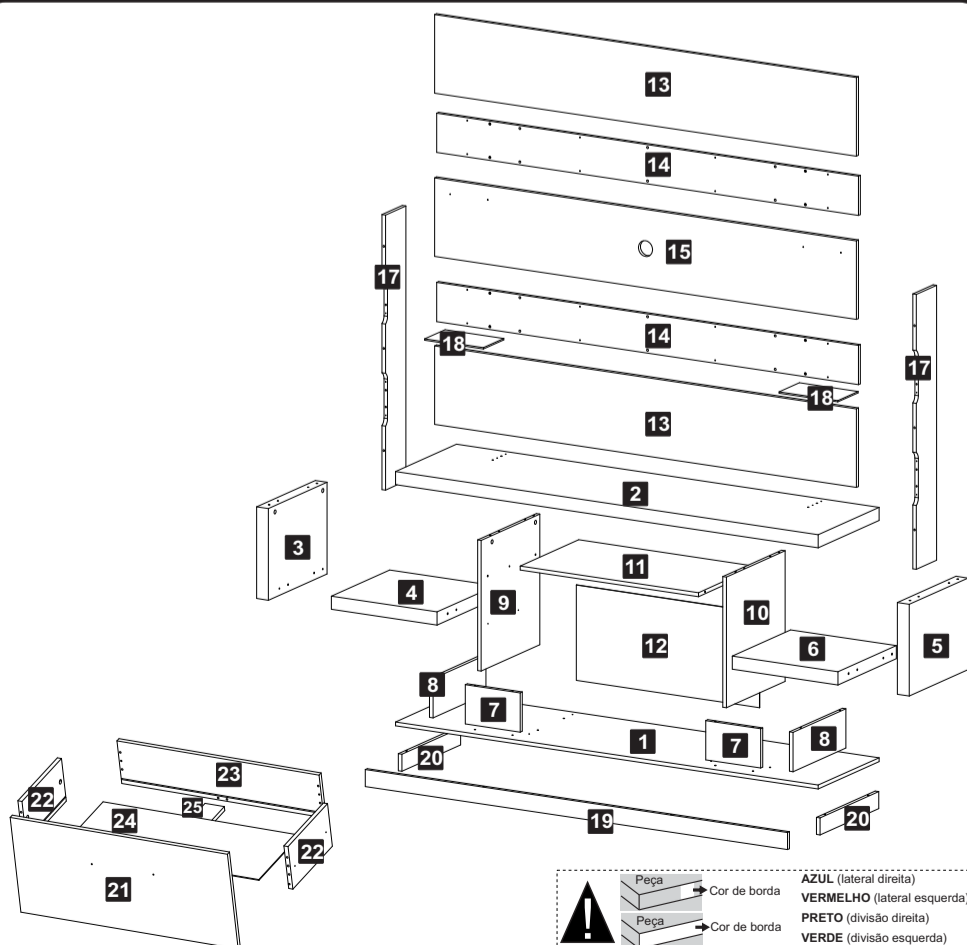

#### Descrição

- 1-Base (1800x450x15mm)
- 2-Tampo (1800x450x50mm)
- 3-Lateral esquerda (350x433x50mm)
- 4-Prateleira esquerda (450x431x50mm)
- 5-Lateral direita (350x433x50mm)
- 6-Prateleira direita (450x431x50mm)
- 7-Travessa frontal (150x234x15mm)
- 8-Travessa lateral (150x390x15)
- 9-Divisão esquerda (499x433x15mm)
- 10-Divisão direita (499x433x15mm)
- 11-Prateleira central (760x432x15mm)
- 12-Traseira (780x364x3mm)
- 13-Painel sup/inf (1796x300x15mm)
- 14-Travessa maior (1796x150x15mm)
- 15- Painel central (1796x300x15mm)
- 17- Travessa menor painel (1050x150x15mm)
- 18- Prateleira de vidro (150x250x5mm)
- 19- Encabeçamento frontal (1798x65x15mm)
- 20- Encabeçamento lateral (433x65x15mm)
- 21- Frente de gaveta (790x356x15mm)
- 22- Lateral de gaveta (306x160x15mm)
- 23- Traseira de gaveta (735x160x15mm)
- 24- Fundo de gaveta (715x316x3mm)
- 25- Travessa gaveta (306x70x15mm)

#### Descrição

- 1-Base
- 2-Tapa
- 3-Lateral izquierda
- 4-Anaqueil izquierda
- 5-Lateral derecha
- 6-Anaqueil derecha
- 7-Travesaño frente
- 8-Travesaño lateral
- 9-División izquierda
- 10-División derecha
- 11-Anaqueil central
- 12-Trasera
- 13-Panel inferior
- 14-Travesaño mayor
- 15-Panel central
- 17-Travesaño menor panel
- 18-Anaqueil vidrio
- 19-Encabezado frente
- 20-Encabezado lateral
- 21-Frente cajón
- 22-Lateral cajón
- 23-Trasera cajón
- 24-Fondo cajón
- 25-Travesaño cajón

Assista ao vídeo com dicas de montagem em nosso site: [www.artely.com.br](http://www.artely.com.br)

**1** Passo  
Passo  
Step

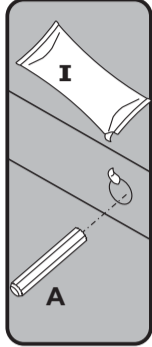
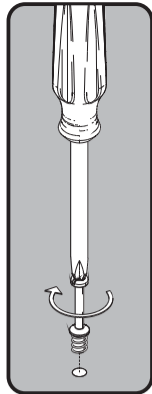
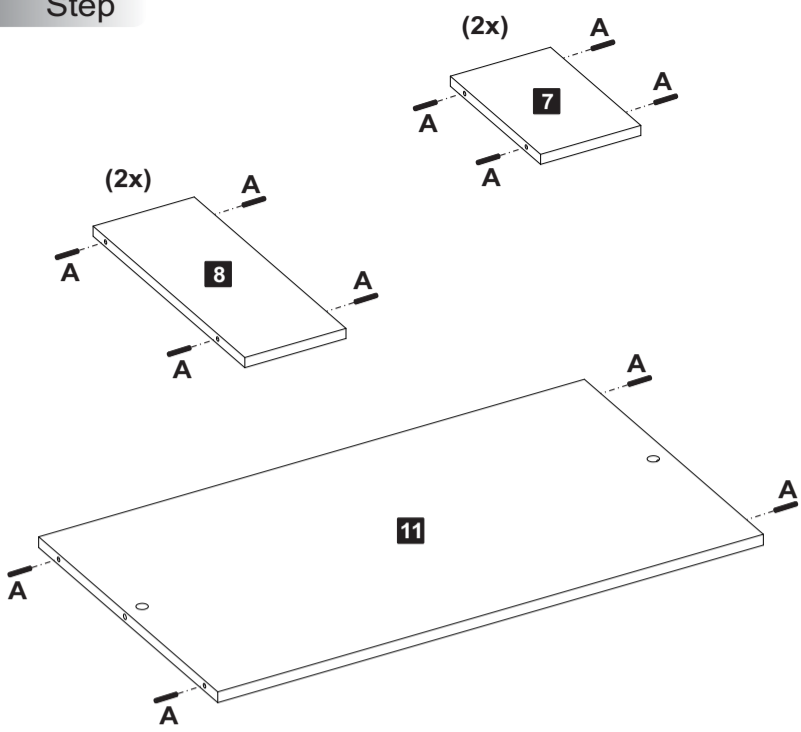

**A** Cavilha 20

**2** Passo  
Passo  
Step

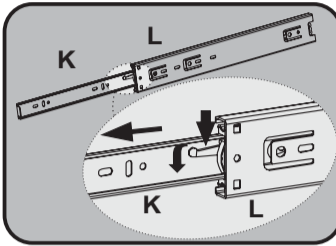
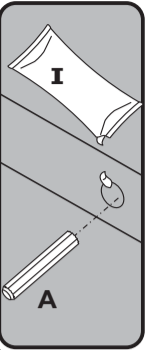
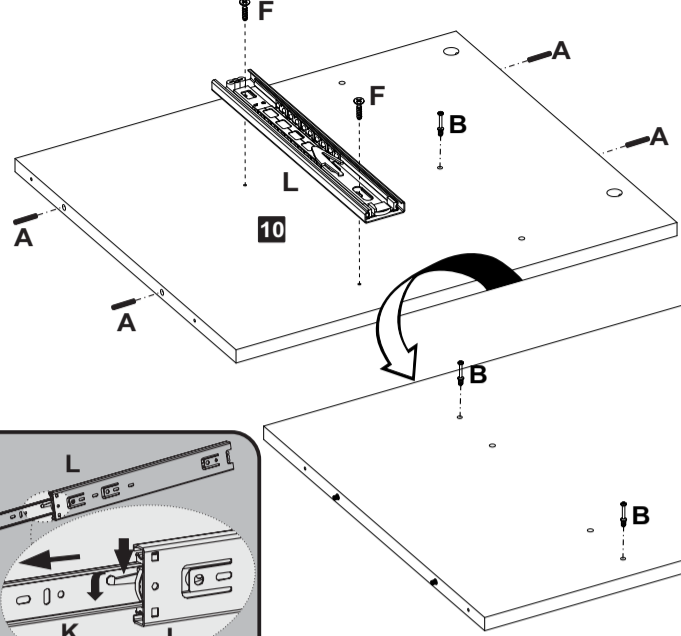
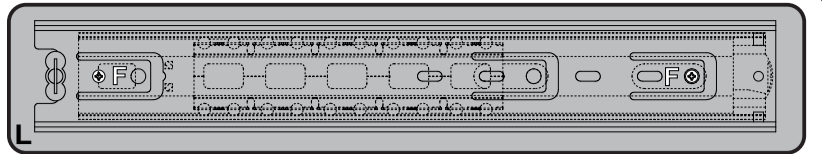

**A** Cavilha 04

**B** Minifix Ø7x30mm 03

**F** Parafuso Ø3,5x12mm CC 02

**L** Correia Telescópica 300mm 01

**3** Passo  
Passo  
Step

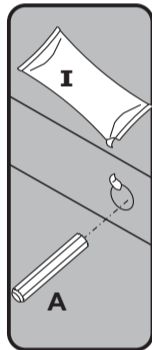
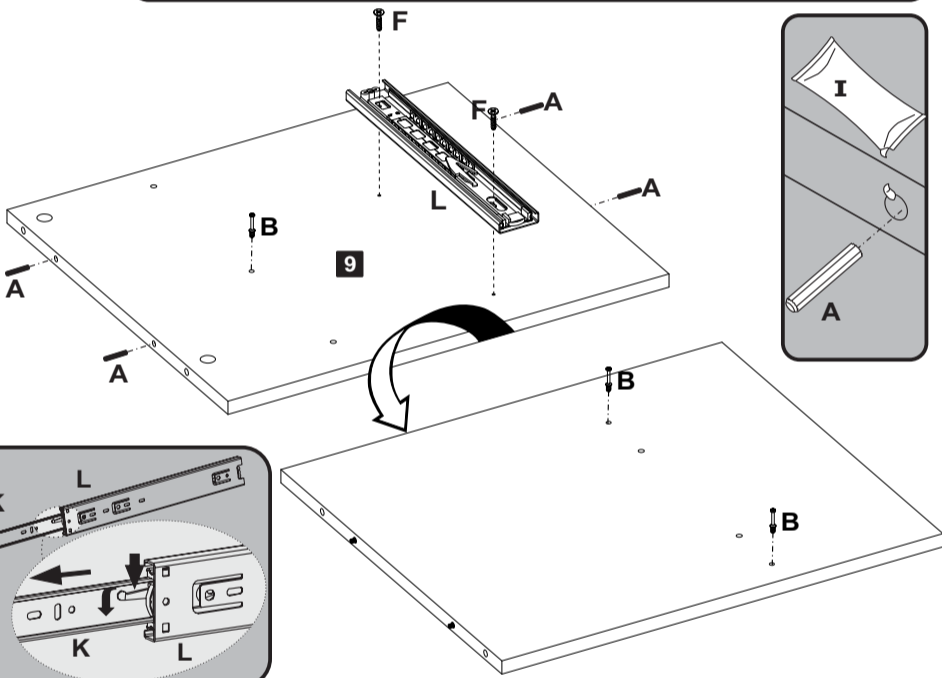
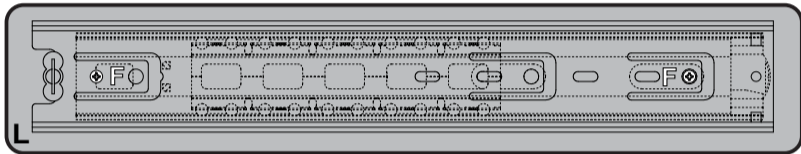

**A** Cavilha 04

**B** Minifix Ø7x30mm 03

**F** Parafuso Ø3,5x12mm CC 02

**L** Correia Telescópica 300mm 01

**4** Passo  
Passo  
Step

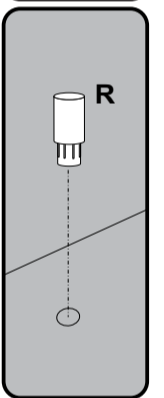
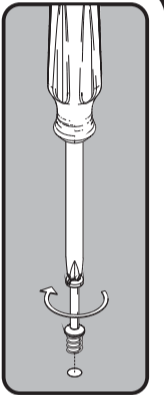
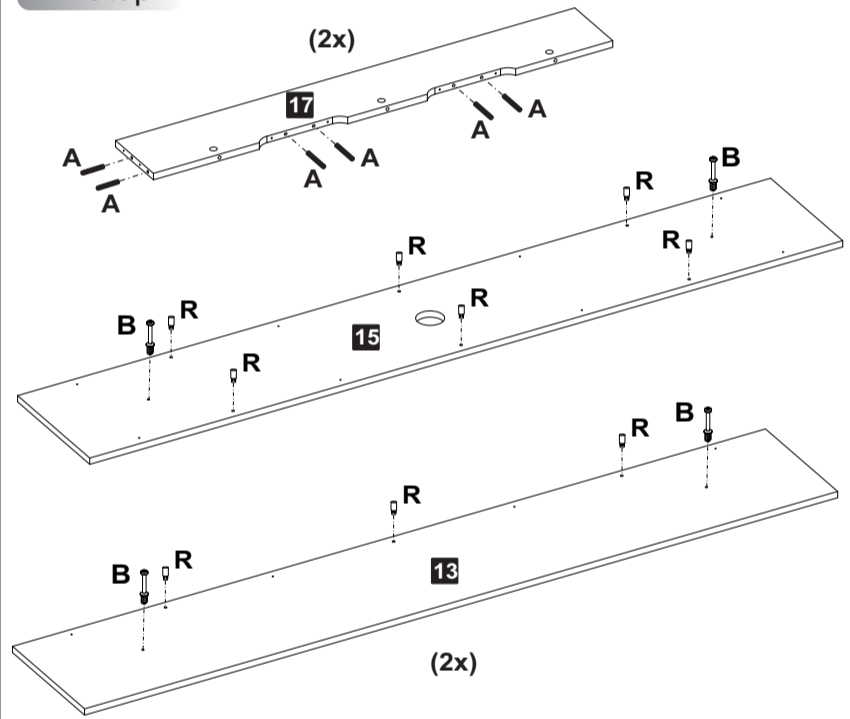

**A** Cavilha 12

**B** Minifix Ø7x30mm 06

**R** Pino Sustentação 12

**5** Passo  
Passo  
Step

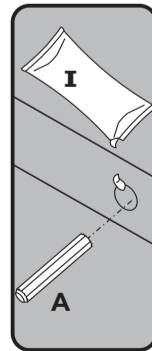
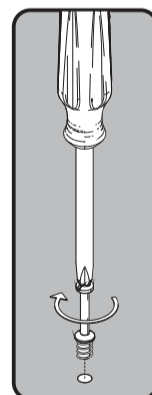
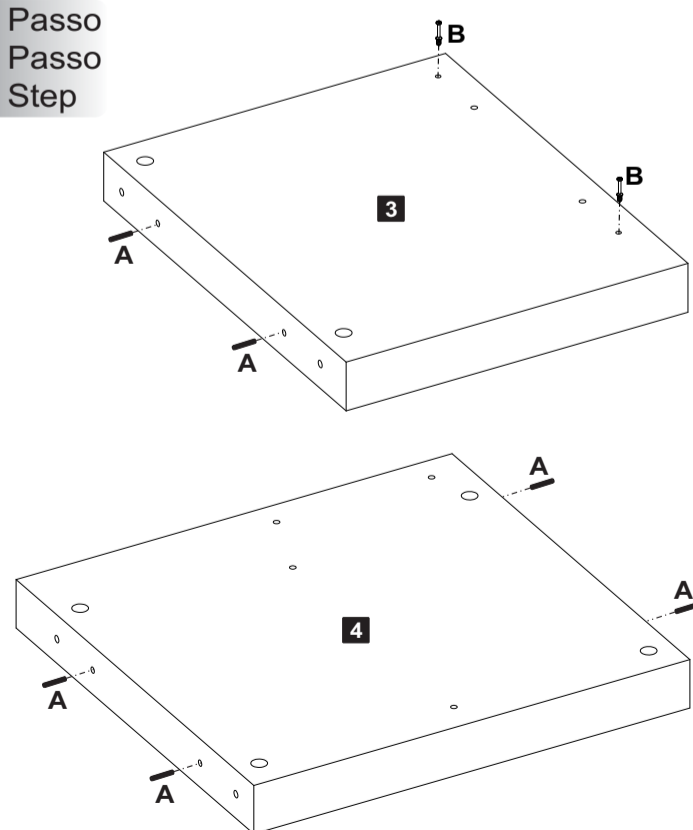

**A** Cavilha 06

**B** Minifix Ø7x30mm 02

**6** Passo  
Passo  
Step

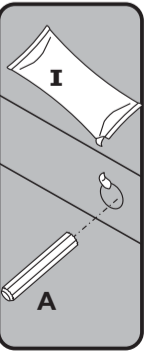
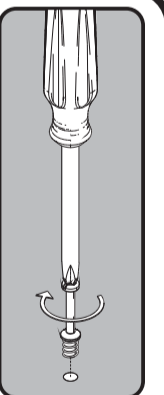
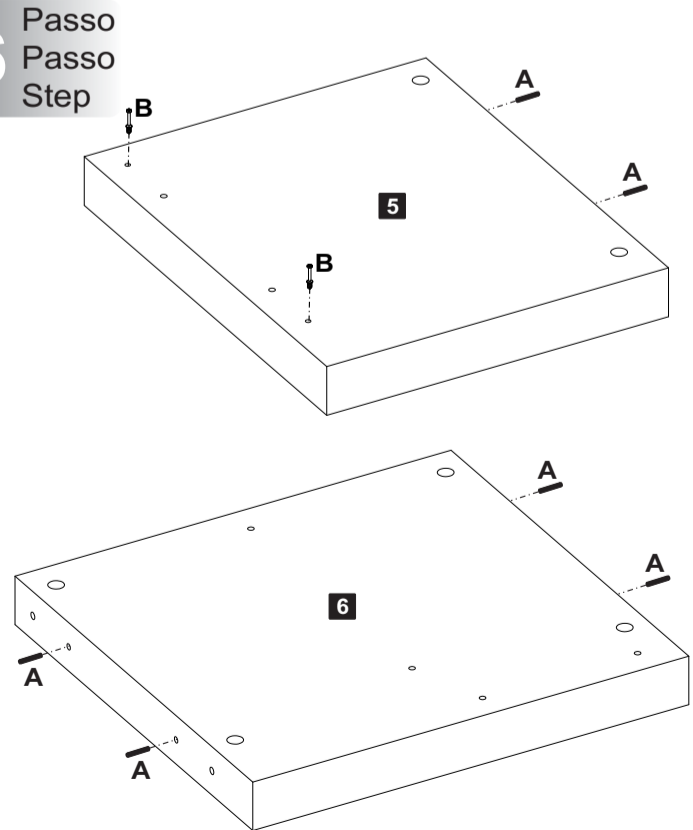

**A** Cavilha 06

**B** Minifix Ø7x30mm 02

7  
Passo  
Passo  
Step

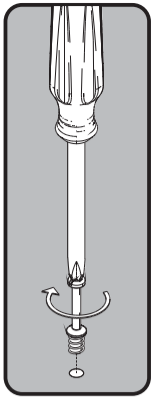
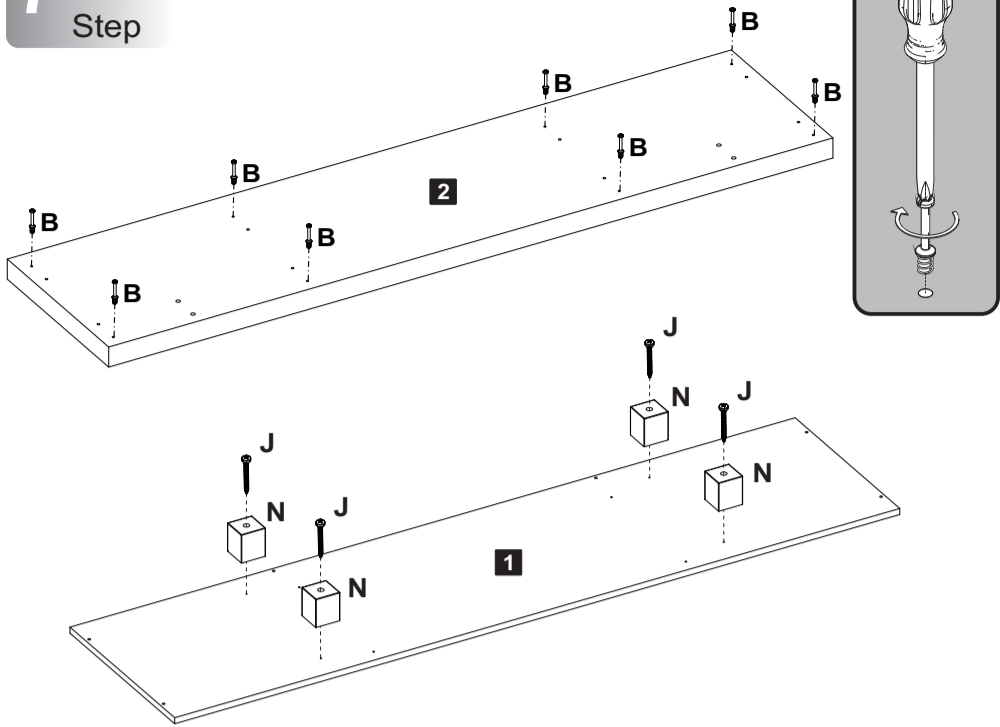

B MiniFix Ø7x30mm 08 J Parafuso Ø4,0x30mm CP 04 N Sapata Square 04

8  
Passo  
Passo  
Step

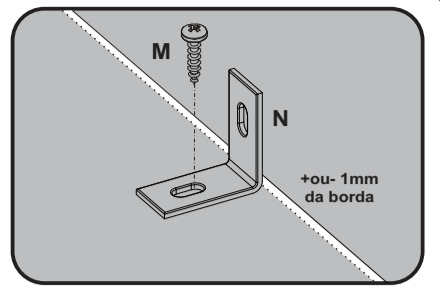
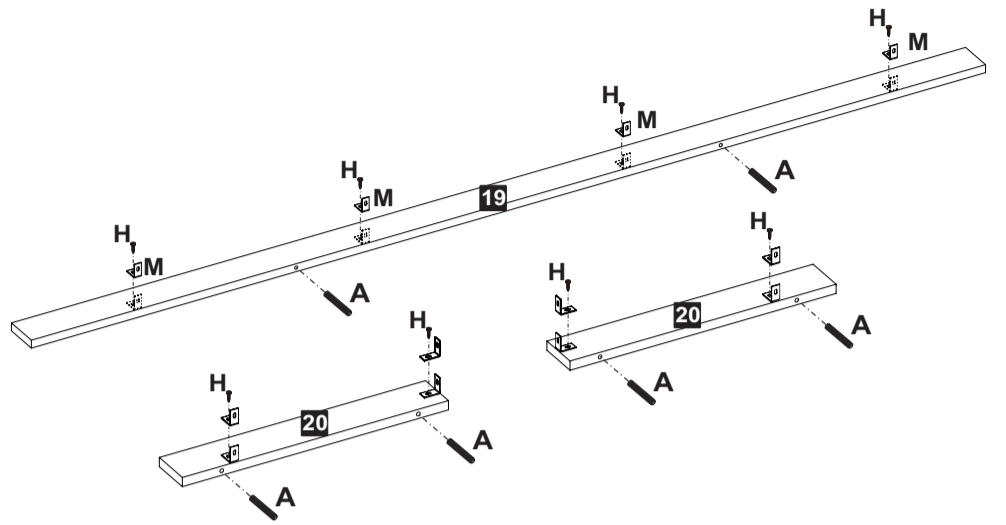

A Cavilha 06 H Parafuso Ø4,0x14mm CP 08 M Cantoneira 1"x1" 08

9  
Passo  
Passo  
Step

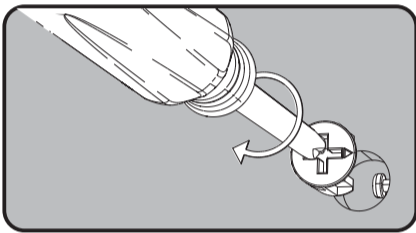
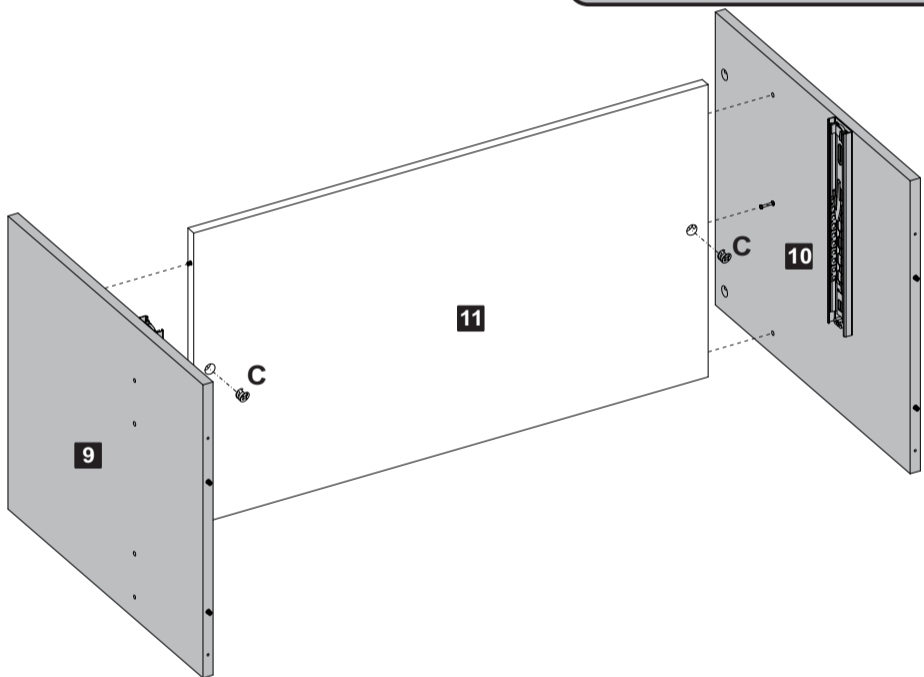

C Tambor 02

10  
Passo  
Passo  
Step

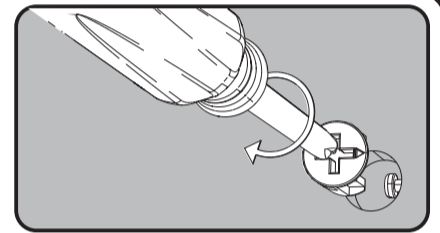
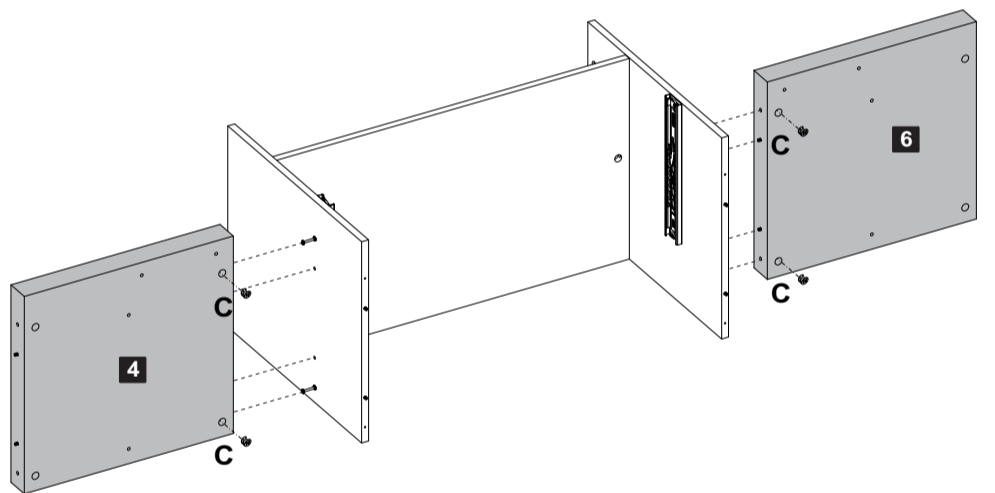

C Tambor 04

11  
Passo  
Passo  
Step

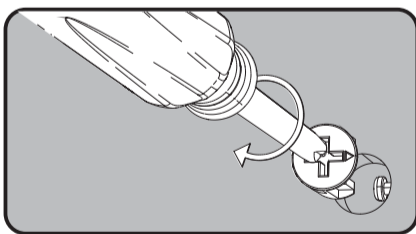
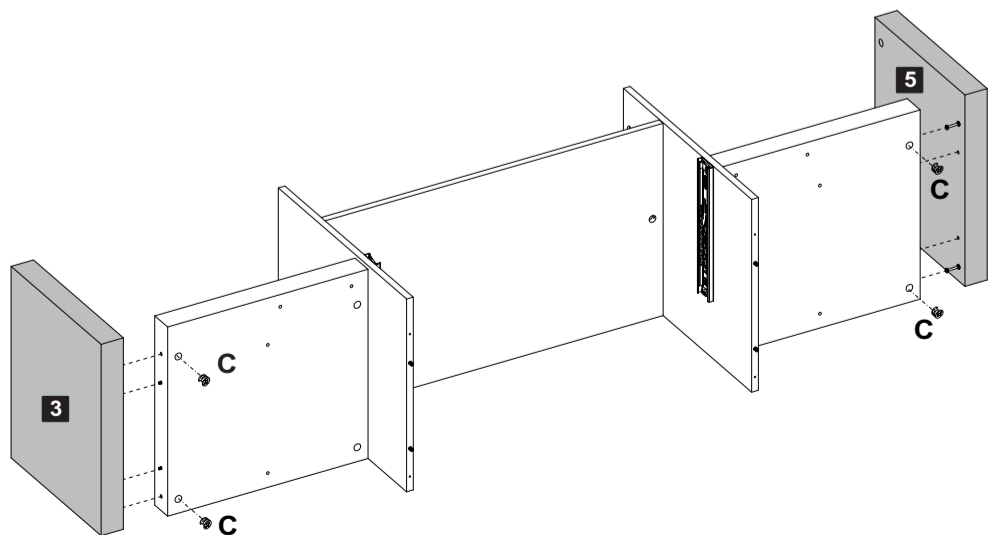

C Tambor 04

12  
Passo  
Passo  
Step

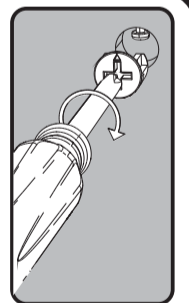
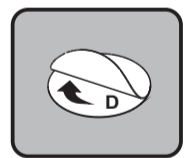
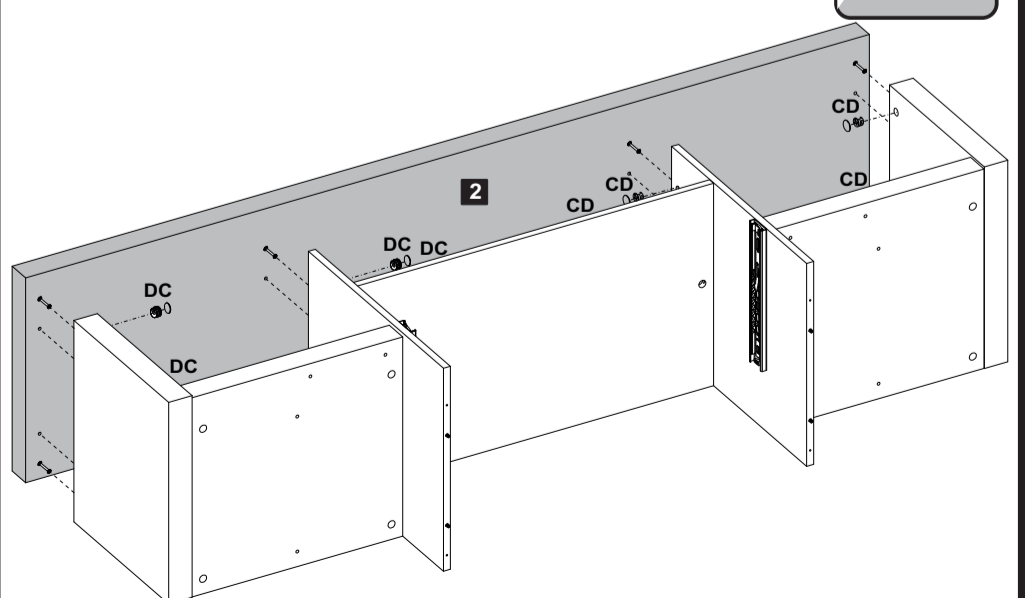

C Tambor 08 D Tapa Furo Adesivo 08

13 Passo  
Passo  
Step

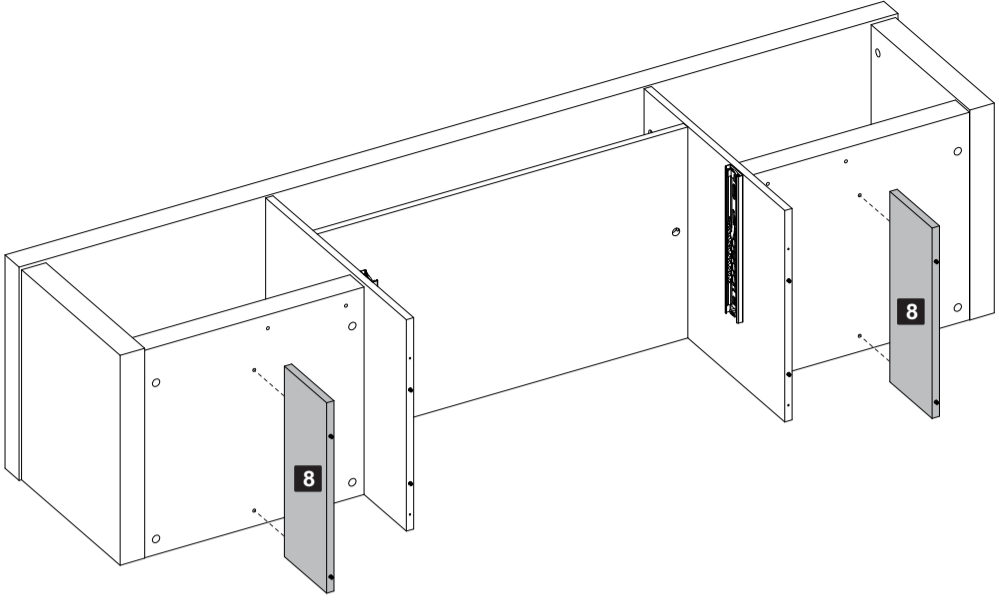

14 Passo  
Passo  
Step

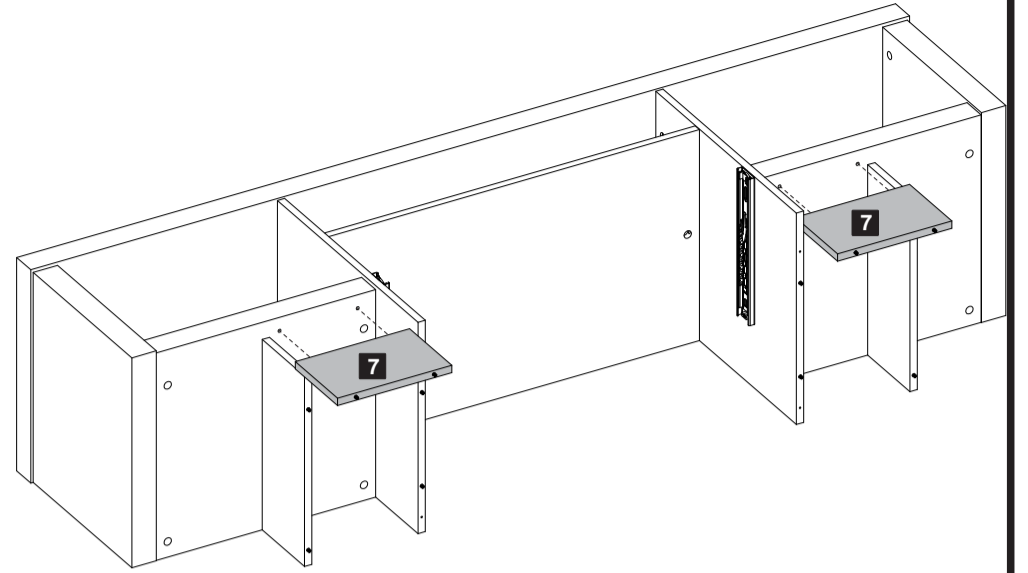

15 Passo  
Passo  
Step

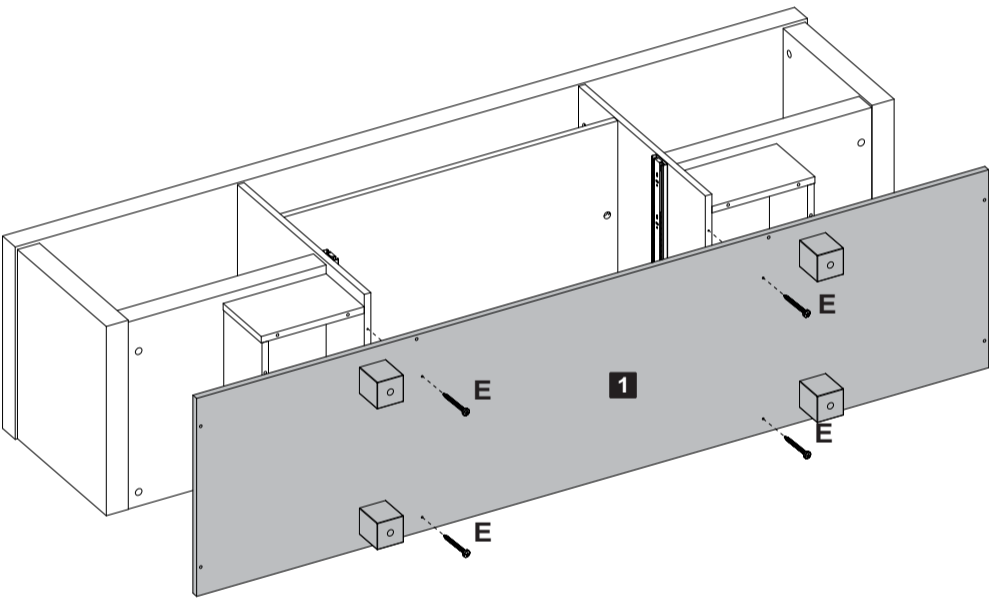

E Parafuso Ø3,5x40mm CP 04

16 Passo  
Passo  
Step

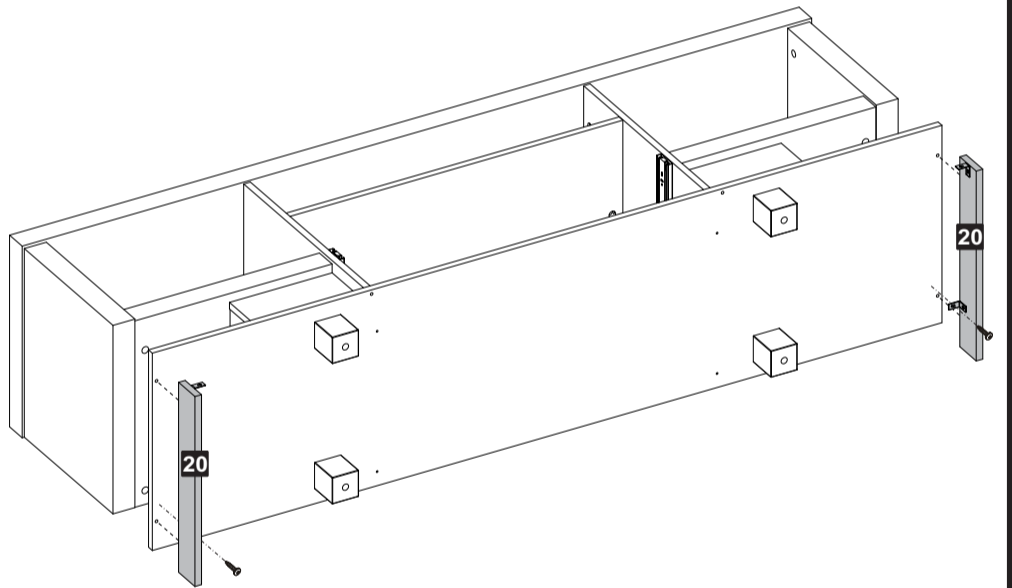
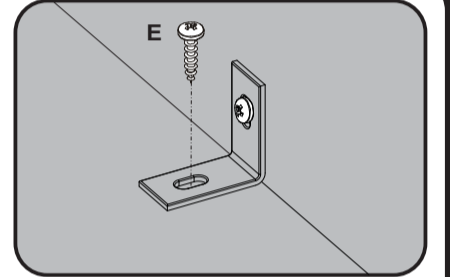

E Parafuso Ø4,0x14mm CP 02

17 Passo  
Passo  
Step

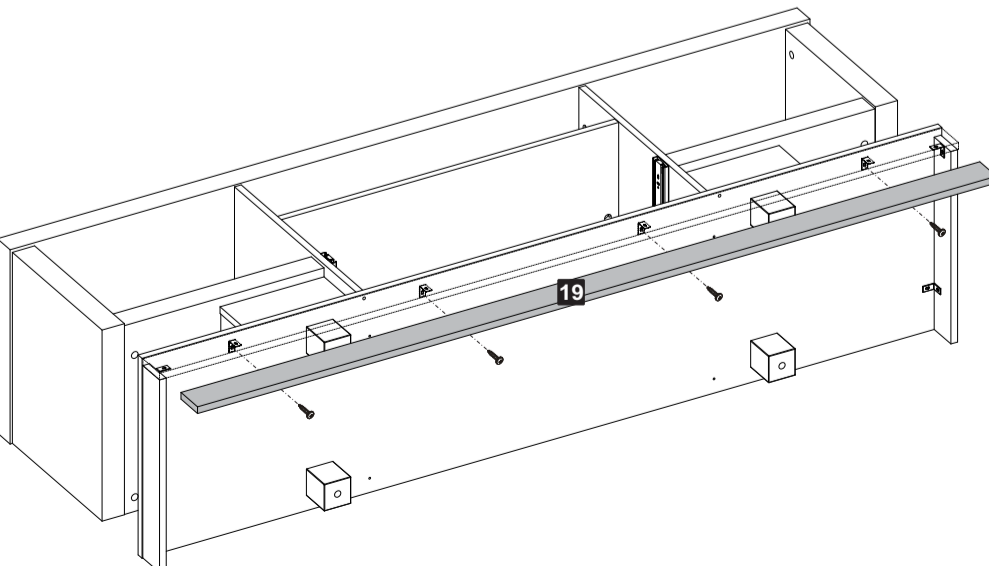
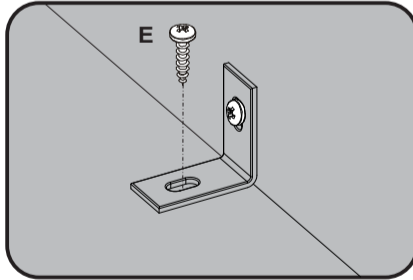

E Parafuso Ø4,0x14mm CP 02

18 Passo  
Passo  
Step

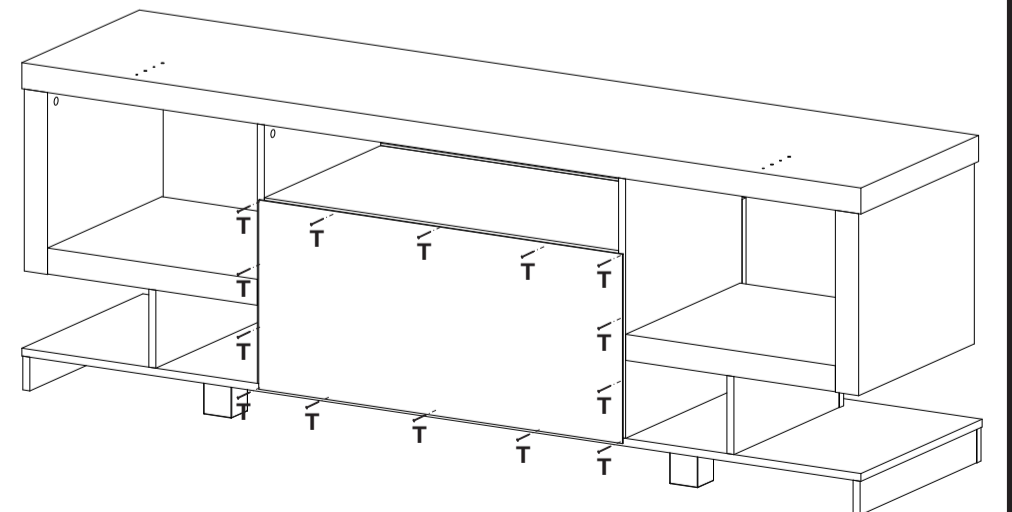

T Prego 8x8 14

**19** Passo  
Passo  
Step

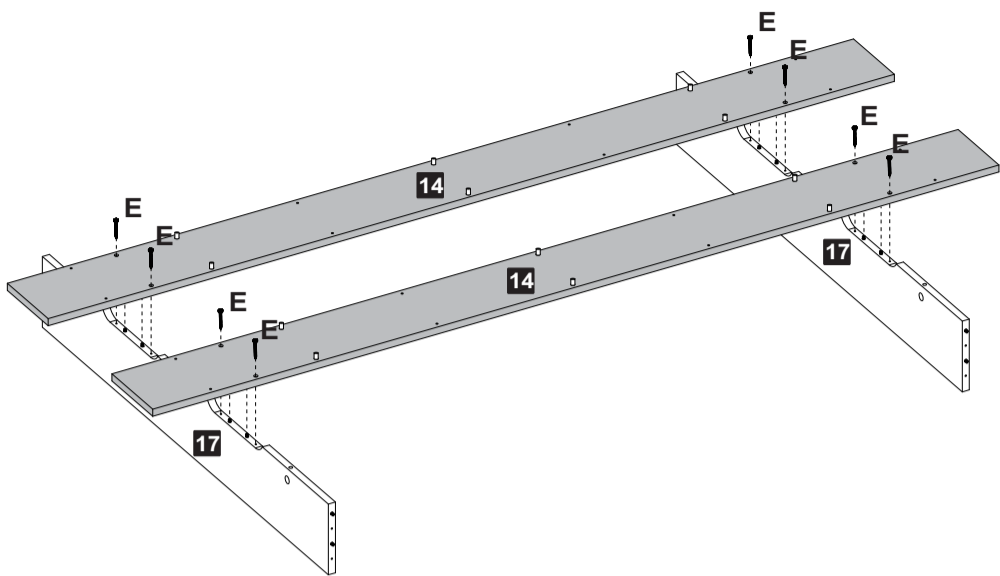

**E** Parafuso Ø3,5x40mm CP 08

**20** Passo  
Passo  
Step

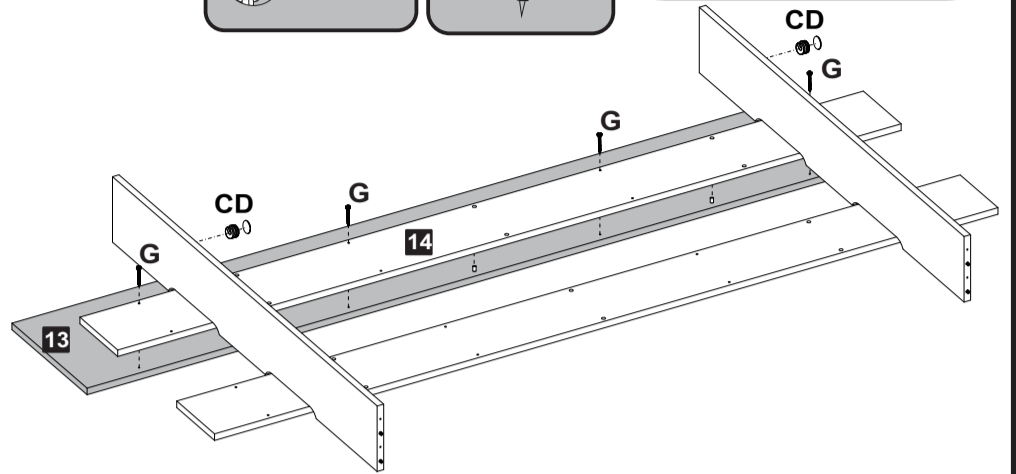
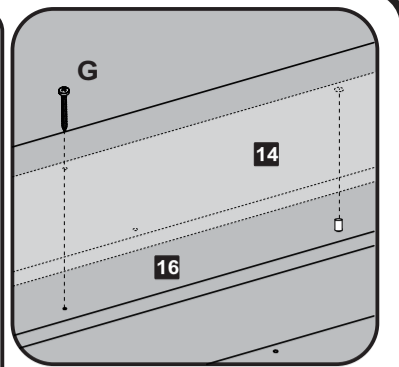
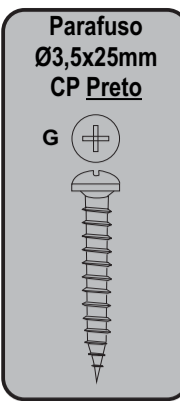
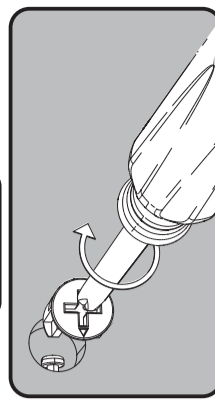
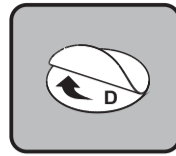

**C** Tambor 02 **D** Tapa Furo Adesivo 02 **G** Parafuso Ø3,5x25mm CP Preto 04

**21** Passo  
Passo  
Step

Opção 1

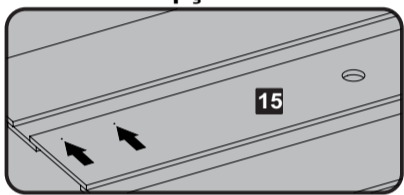

Opção 2

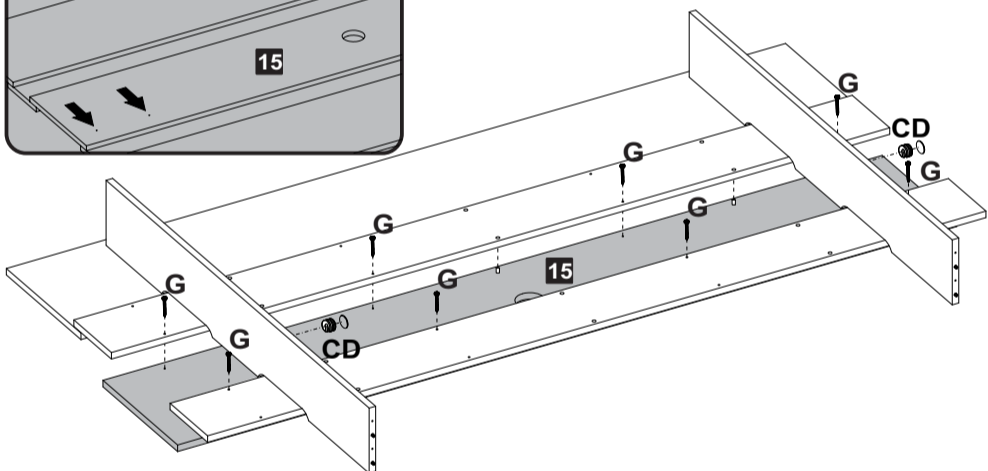
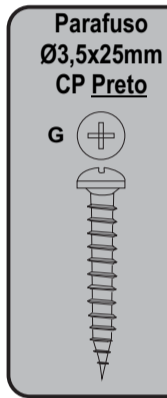
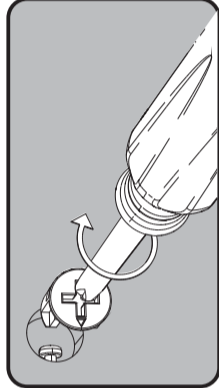
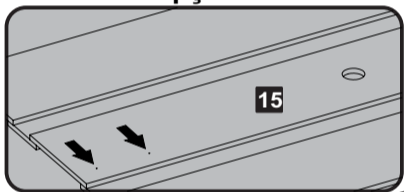

**C** Tambor 02 **D** Tapa Furo Adesivo 02 **G** Parafuso Ø3,5x25mm CP Preto 08

**22** Passo  
Passo  
Step

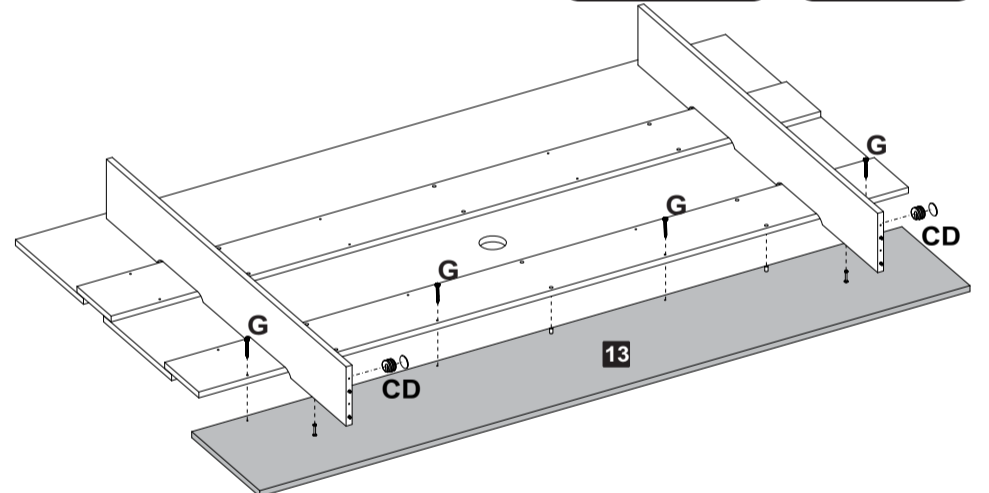
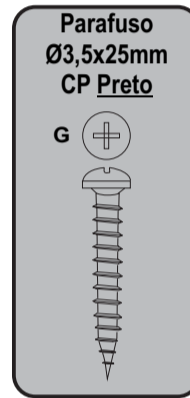
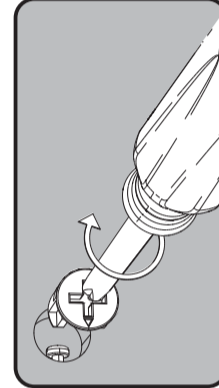
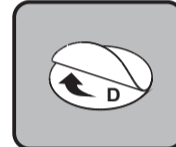

**C** Tambor 02 **D** Tapa Furo Adesivo 02 **G** Parafuso Ø3,5x25mm CP Preto 04

**23** Passo  
Passo  
Step

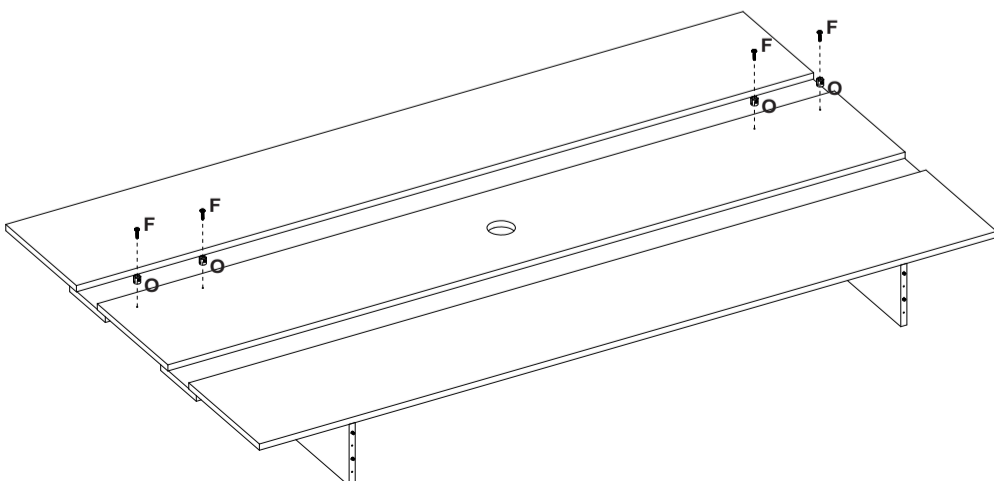
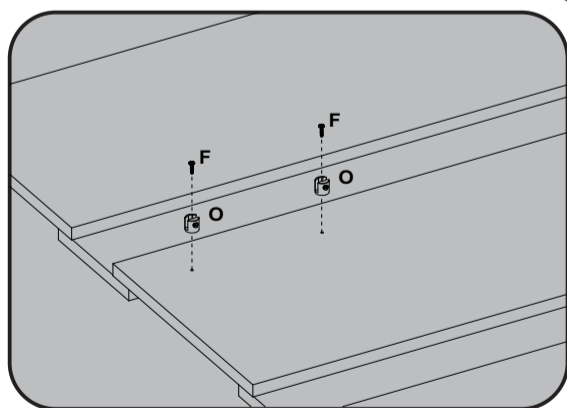

**F** Parafuso Ø3,5x12mm CC 04 **O** Suporte Vidro 04

**24** Passo  
Passo  
Step

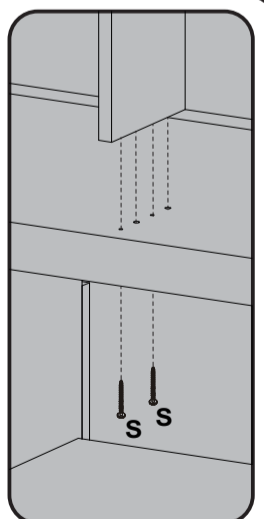
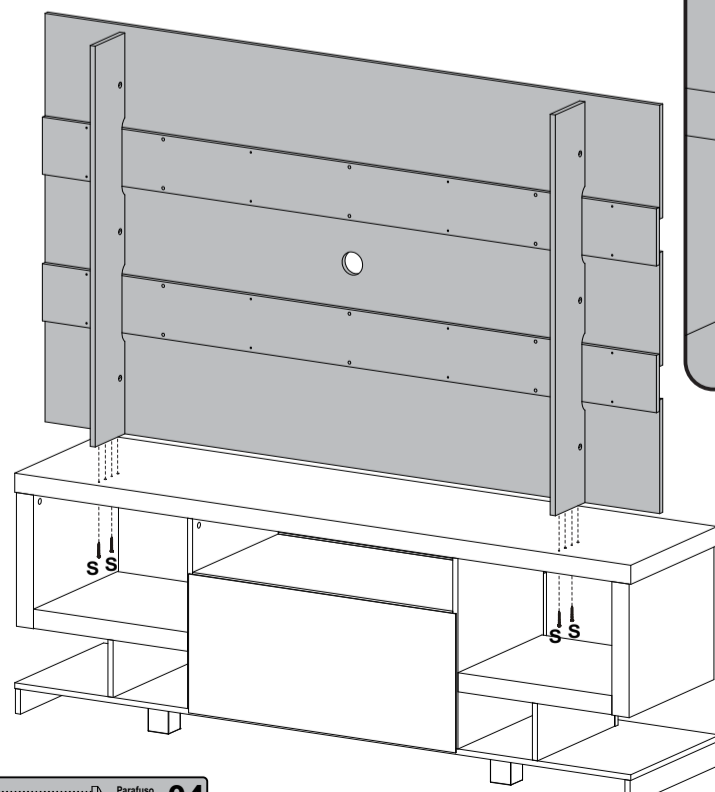

**S** Parafuso Ø4x45mm CP 04

**25** Passo  
Passo  
Step

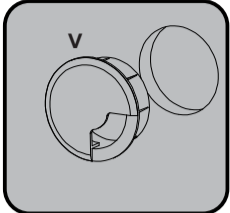
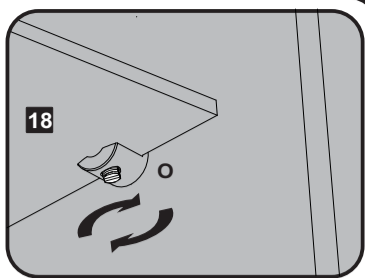
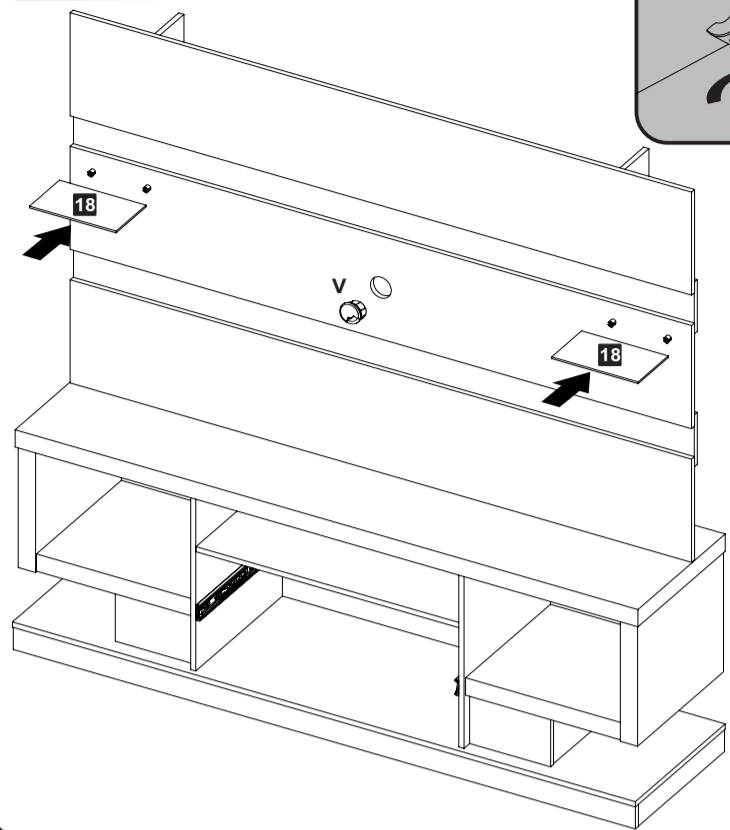

**26** Passo  
Passo  
Step

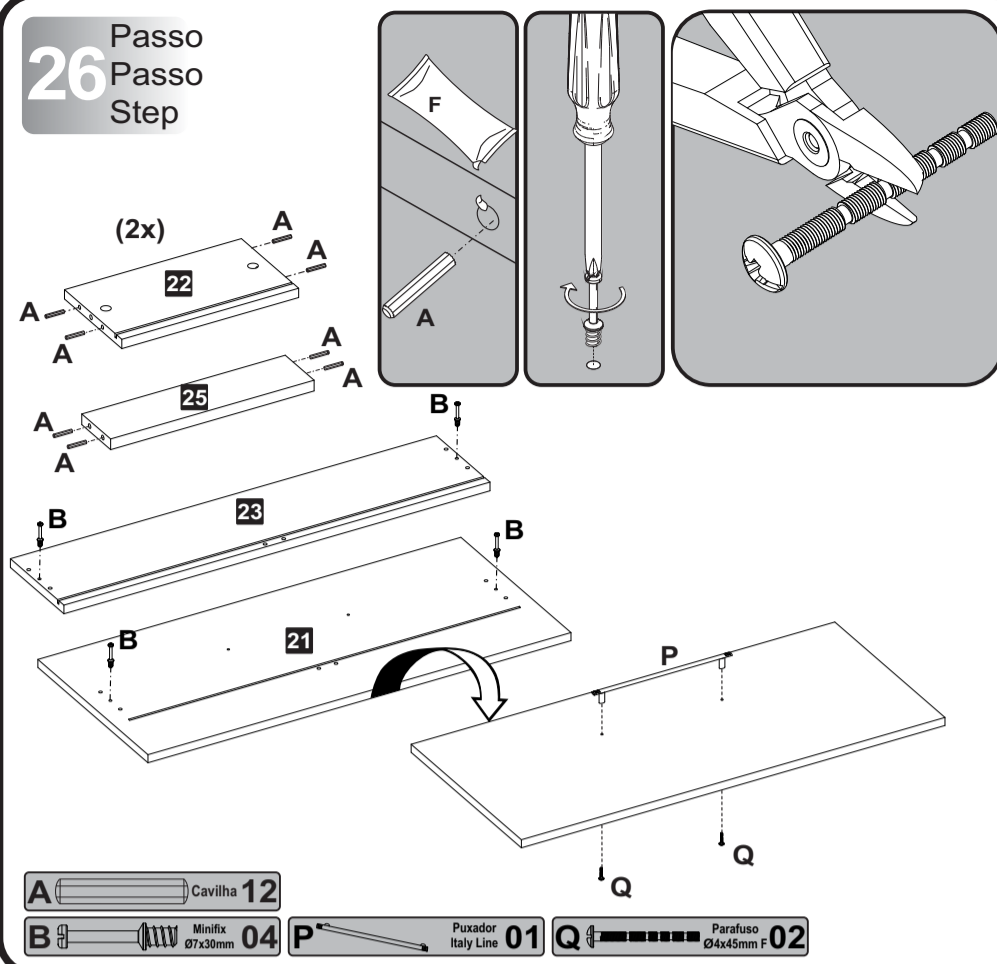

- A** Caviha 12
- B** Minifix Ø7x30mm 04
- P** Puxador Italy Line 01
- Q** Parafuso Ø4x45mm F 02

**27** Passo  
Passo  
Step

**1** Passo  
Passo  
Step

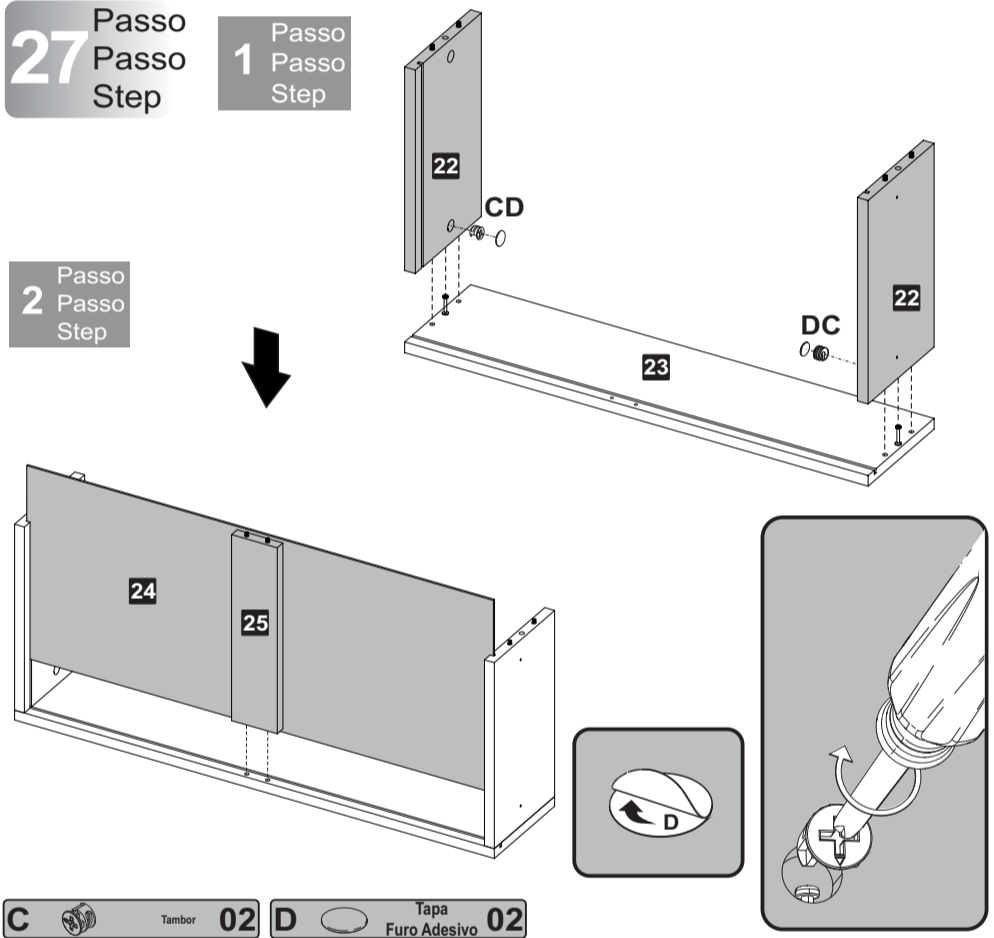

- C** Tambor 02
- D** Tapa Furo Adesivo 02

**28** Passo  
Passo  
Step

**3** Passo  
Passo  
Step

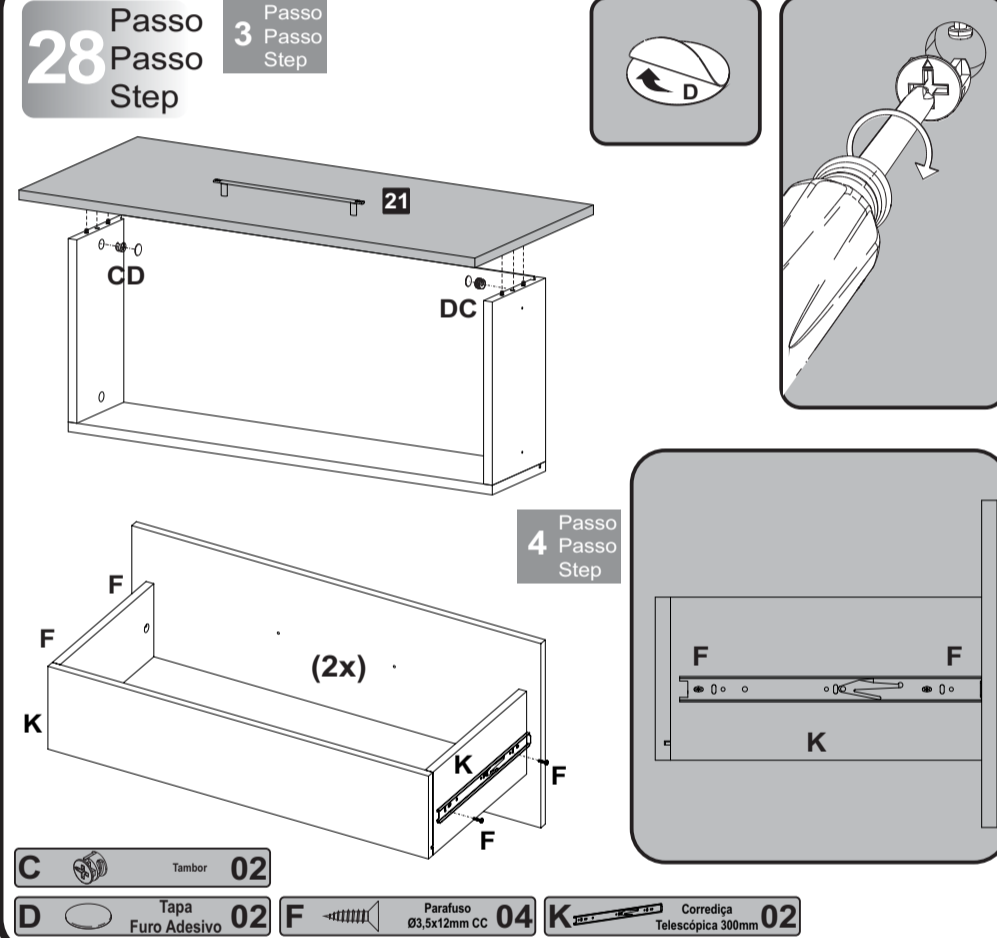

- C** Tambor 02
- D** Tapa Furo Adesivo 02
- F** Parafuso Ø3,5x12mm CC 04
- K** Corrediza Telescópica 300mm 02

**29** Passo  
Passo  
Step

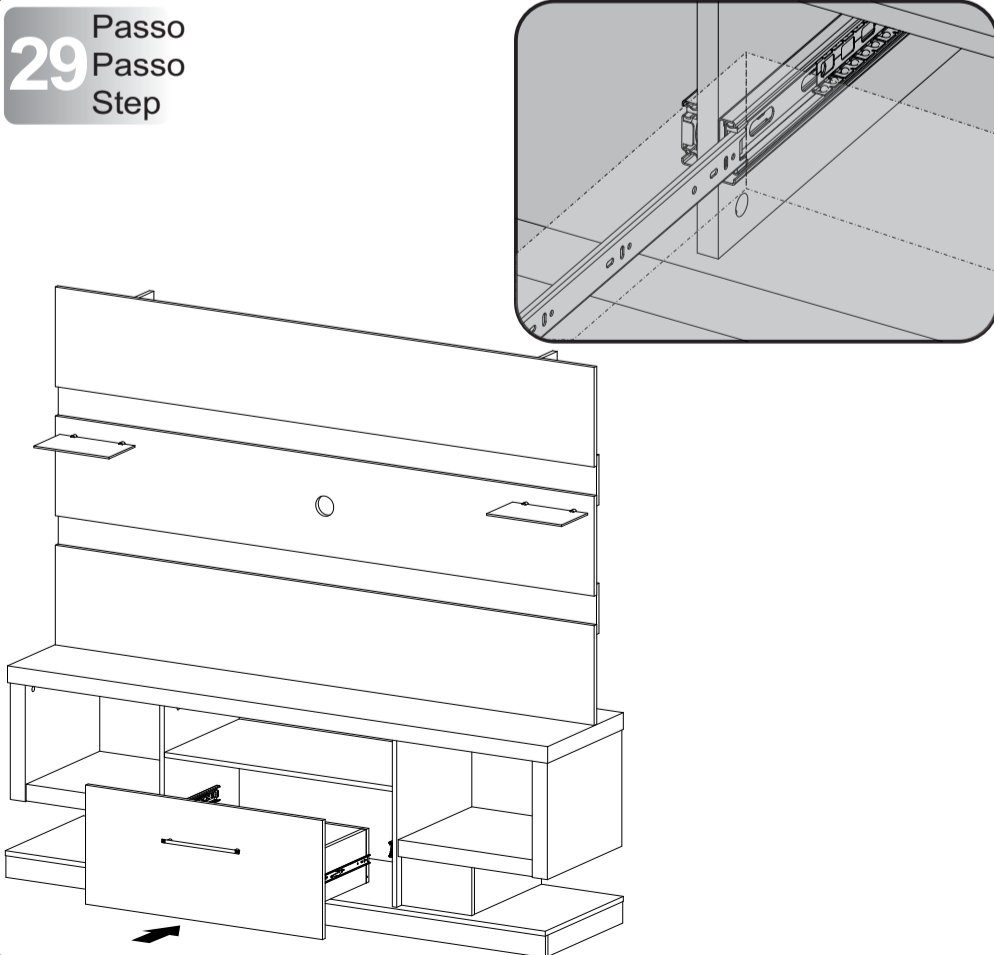

**30** Passo  
Passo  
Step

<b>U</b>	 kit suporte TV U1 35x77mm    U2 48x28mm    U3 100x56mm	<b>2</b>
	U4  Parafuso M4 x 16	<b>4</b>
	U5  Parafuso M5 x 16	<b>4</b>
	U6  Parafuso M6 x 16	<b>4</b>
U7  Parafuso M8 x 16	<b>4</b>	

**31** Passo  
Passo  
Step

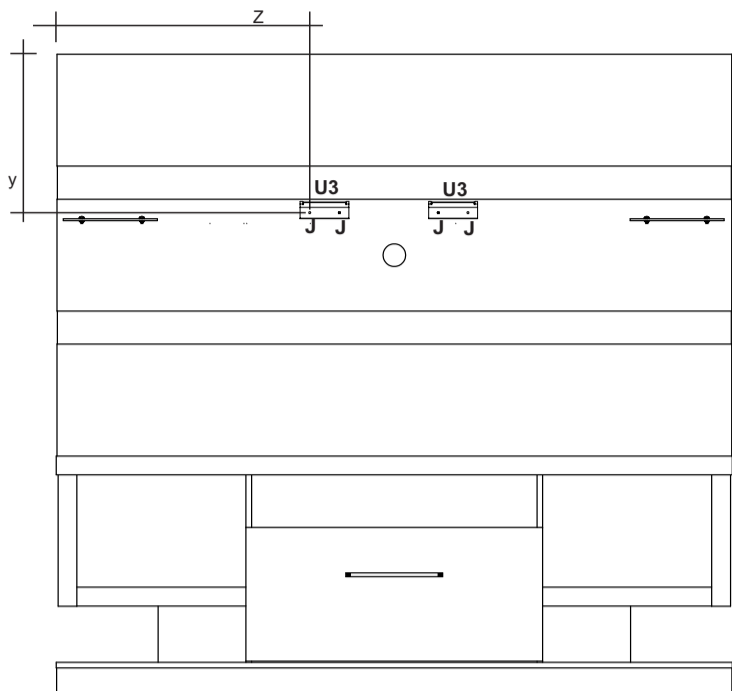

J



Utilizar a Norma VESA do manual da TV, para calcular a centralização e altura da TV no painel.

Usando el manual del estándar VESA TV, centralización y para calcular la altura del panel de TV.

Using the VESA standard TV's manual, centralization and to calculate the height of the TV panel.

J Parafuso 64,6x38mm CP 4 U3 Kit Suporte TV 2

**32** Passo  
Passo  
Step

**Suporte Superior**

Utilizar o parafuso indicado no manual da TV U4,U5,U6,U7(VESA).  
Use el tornillo indicado del televisor manual U4,U5,U6,U7(VESA).  
Use the screw indicated the TV's manual U4,U5,U6,U7(VESA).

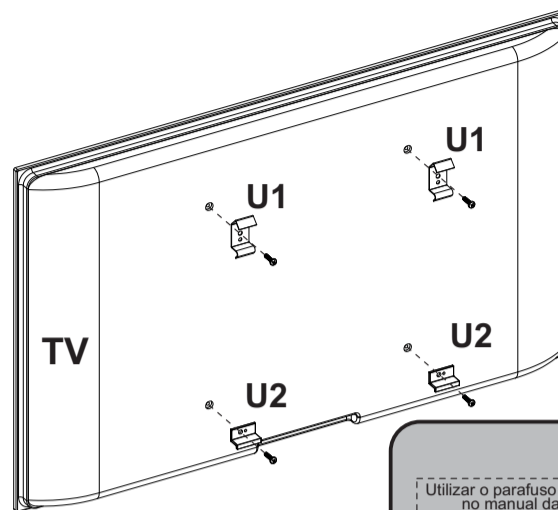
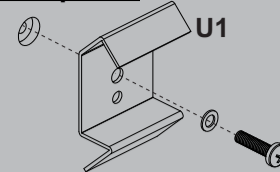

**Suporte Inferior**

Utilizar o parafuso indicado no manual da TV U4,U5,U6,U7(VESA).  
Use el tornillo indicado del televisor manual U4,U5,U6,U7(VESA).  
Use the screw indicated the TV's manual U4,U5,U6,U7(VESA).

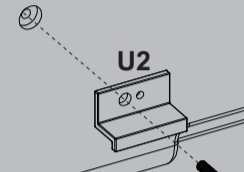

U1 Kit Suporte TV 2

U2 Kit Suporte TV 2

**33** Passo  
Passo  
Step

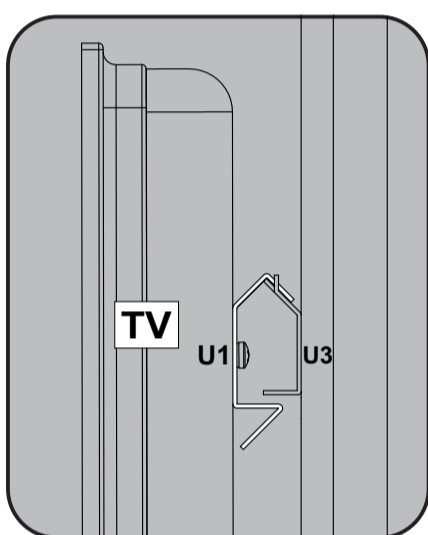
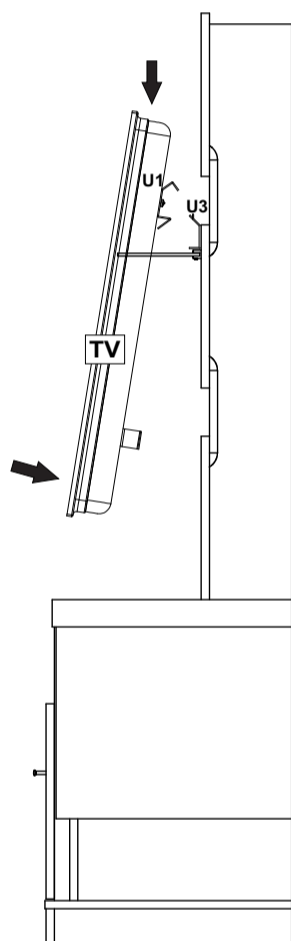

**Garantia**

Este certificado de Garantia é uma vantagem adicional oferecida ao consumidor, porém para que o mesmo tenha validade é imprescindível que seja apresentada a NOTA FISCAL de compra do produto.

Com este produto, a **Artely** tem como objetivo atender plenamente o proprietário-consumidor, proporcionando a garantia na forma aqui estabelecida, pelo período de três meses a partir da data da nota fiscal de compra. A **Artely** restringe a sua responsabilidade à substituição gratuita das peças defeituosas, em caso de defeitos ou avarias devidamente constatados como sendo de fabricação, durante a vigência desta garantia.

A **Artely** declara a garantia nula e sem efeito se o produto for alterado, adulterado, molhado ou consertado e ainda pela prática de montagem inadequada ou mau uso. Também será considerada nula em casos de força maior, como aqueles causados por agentes da Natureza (chuvas, incêndios, excesso de umidade...) e eventos externos como objetos arrastados sobre a superfície do móvel (ex.: TV, DVD, aparelho de som, objetos decorativos...).

Para exercer seus direitos de comprador é importante que antes de montar seu produto você leia com atenção as instruções de cada passo do manual de montagem que acompanha o móvel.

Caso o produto não esteja em conformidade, entre em contato com a loja onde efetuou a compra ou com o nosso Serviço de Atendimento ao Cliente através do e-mail [assistencia@artely.com.br](mailto:assistencia@artely.com.br) ou pelo fone 41 3381 5000 e faça sua reclamação, apontando os defeitos técnicos observados, que teremos o maior prazer em atendê-lo. Para agilizar o seu atendimento, tenha sempre em mãos o manual de montagem com os respectivos números das peças defeituosas, conforme descritas no manual.

**ARTELY**  
Nº 1 em Complementos

ARTELY MÓVEIS LTDA  
ALAMEDA ARPO, 2333  
CEP / ZIP CODE: 83010-290  
SÃO JOSÉ DOS PINHAIS  
CURITIBA - PR - BRASIL  
Fone / Fax: 41 3381-5000  
Phone Number: 55 41 3381-5000  
e-mail: [artely@artely.com.br](mailto:artely@artely.com.br)  
[www.artely.com.br](http://www.artely.com.br)