

Passo
Paso
Step **10**

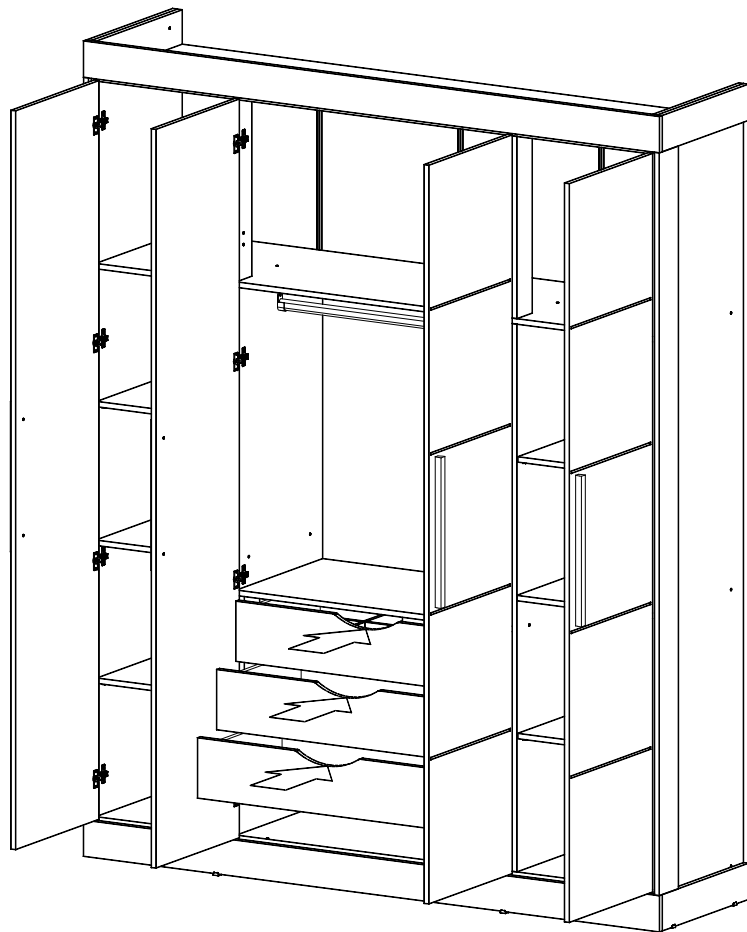

**INSTRUÇÕES DE MONTAGEM
INSTRUCCIONES DE ARMADO
ASSEMBLY INSTRUCTIONS**

REF.: 2322

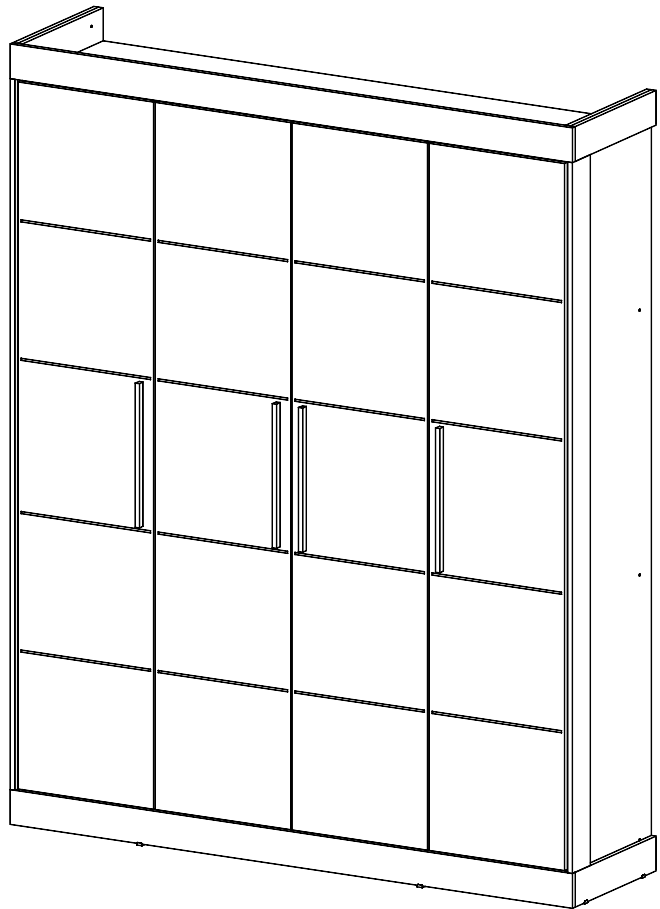

MULTIMÓVEIS

baby

Rua Carlos Dreher Neto, 1918, Fone: (54) 2102 4000, FAX: (54) 2102 4050
CEP 95700-000 - BENTO GONÇALVES - RS - BRASIL
CNPJ: 00.349.443/0001-92
e-mail: multimoveis@multimoveis.com / site: www.multimoveis.com

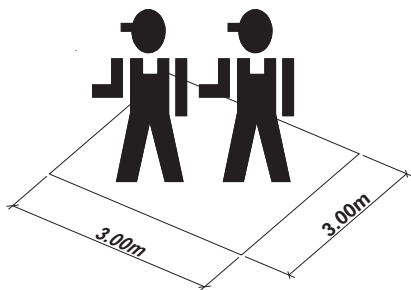



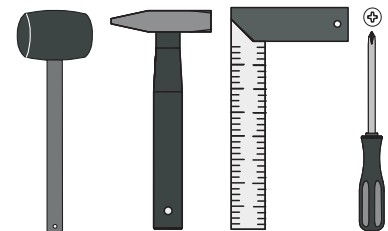





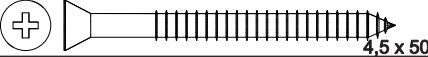



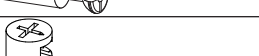
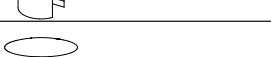
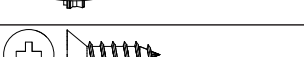
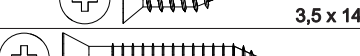
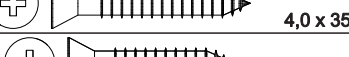

**FERRAMENTAS NECESSÁRIAS
HERRAMIENTAS NECESARIAS
TOOLS NECESSARY**

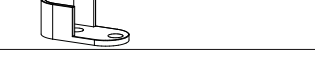
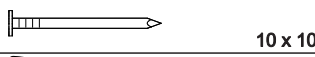
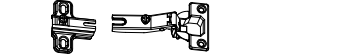

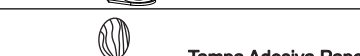
90 min

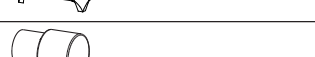

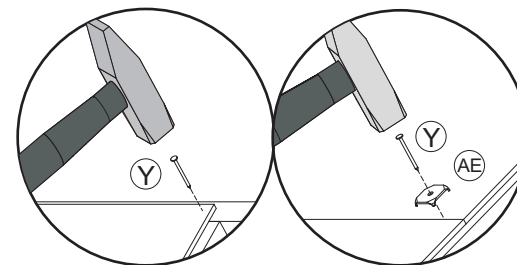
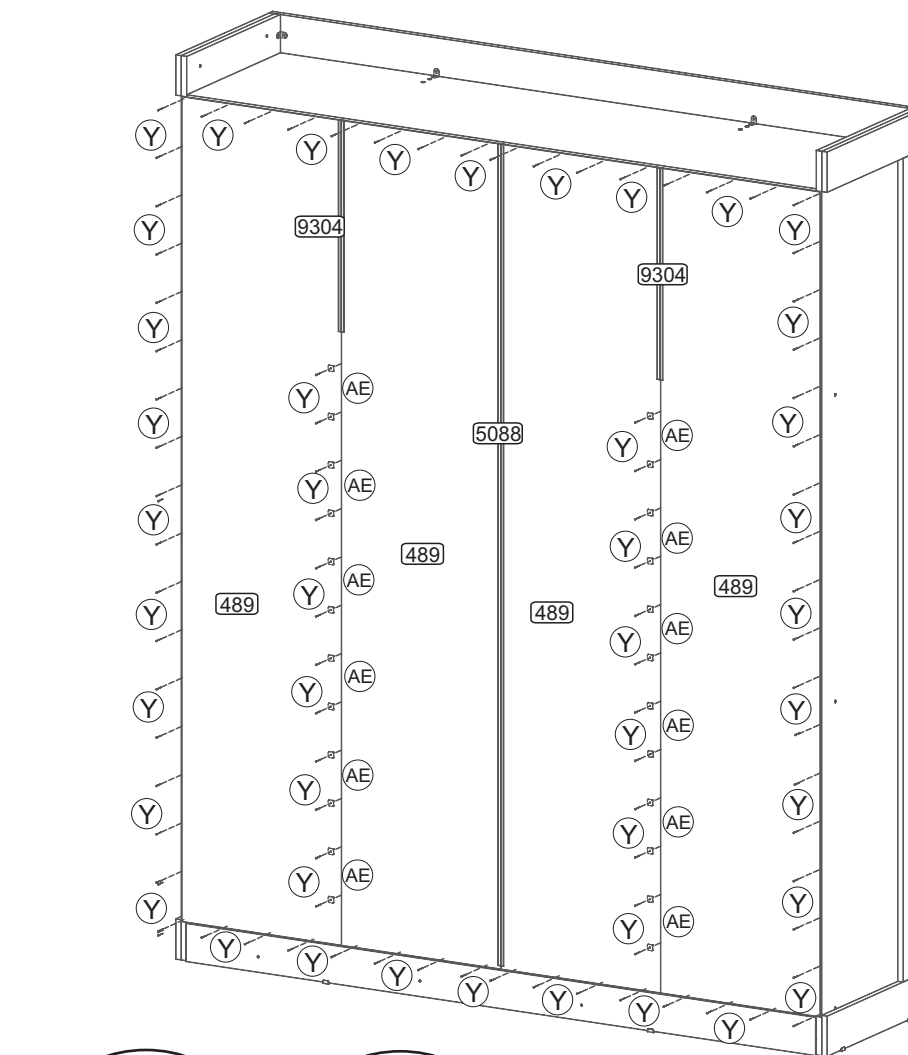

B		30
H		42
J		04
AG		18
N		06
O		06
P		06
E		94
K		28
BA		20
BW		08
CC		12
W		02
Y		120
AA		16
BZ		08
AT		04
ED		22
BX		02
AE		30
DX		16
PX		04
GO		03
	Corrediça Telescópica	

Utilizar a régua abaixo para medir as ferragens:
medidas em mm

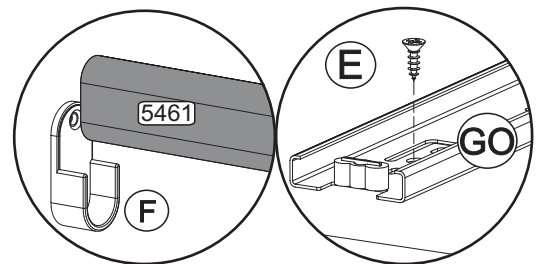
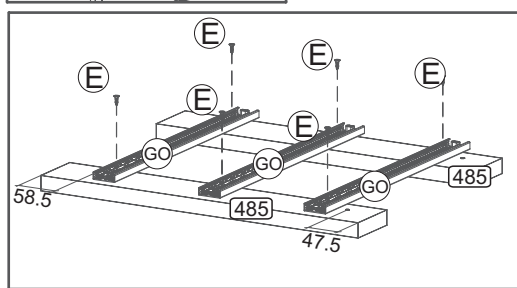
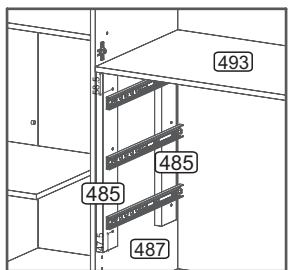
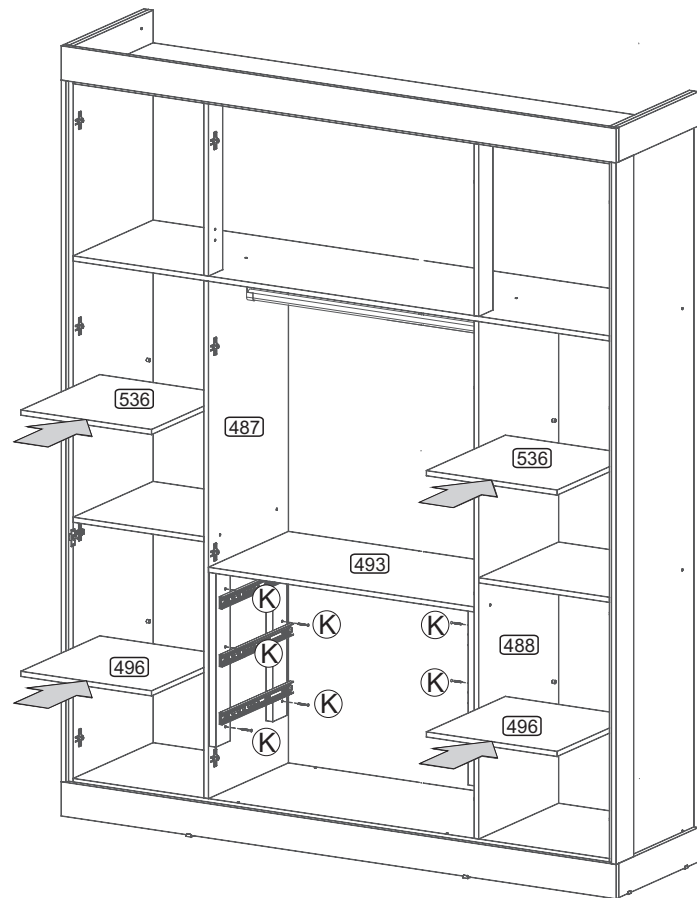





 **Senhor montador!**
Informamos que a numeração das peças encontra-se no topo das mesmas conforme desenho acima.

 **Señor Armador!**
Les informamos que la numeración de las piezas encuentranse arriba de las mismas, de acuerdo al modelo arriba.

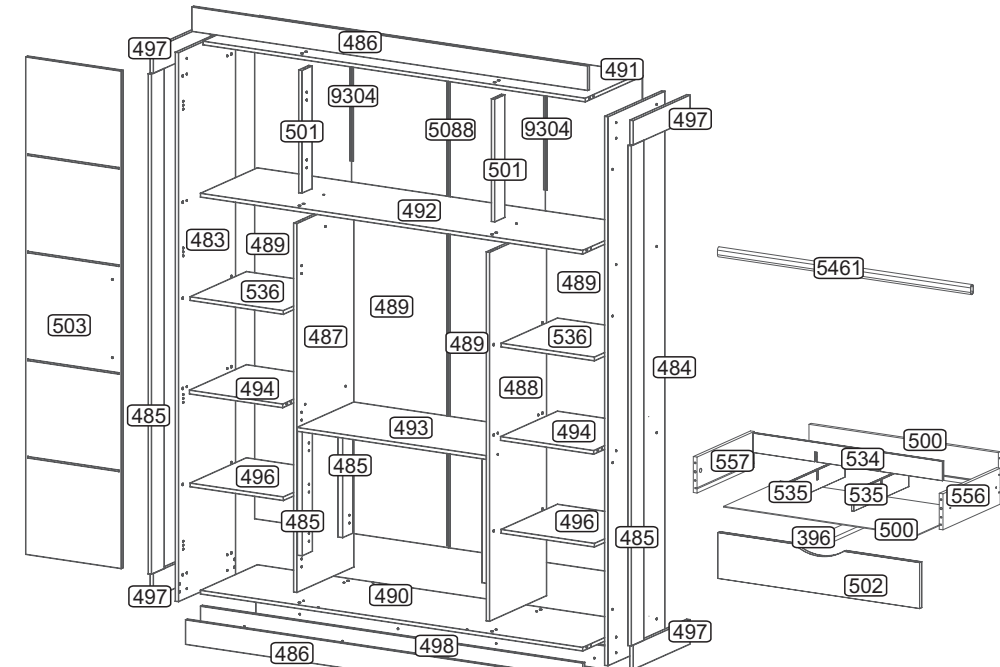
Dear Assembler!
We inform you that the number of each piece is located on the top of it, according to the model shown above.



POR LISTA DE PEÇAS		ESP LISTA DE PIEZAS		ENG PART LIST	
N°	DENOMINAÇÃO	N°	DENOMINACIÓN	N°	DESCRIPTION
557	LATERAL GAVETA ESQUERDA	557	LATERAL CAJÓN IZQUIERDA	557	LEFT DRAWER SIDE
396	TRAVESSA P/ GAVETA	396	BANDEJA P/ CAJÓN	396	DRAWER BEAM
483	LATERAL ESQUERDA	483	LATERAL IZQUIERDA	483	LEFT SIDE
484	LATERAL DIREITA	484	LATERAL DERECHA	484	RIGHT SIDE
485	MOLDURA MAIOR	485	MOLDURA MAYOR	485	LARGER FRAME
486	MOLDURA	486	MOLDURA	486	FRAME
487	DIVISÃO ESQUERDA	487	DIVISIÓN IZQUIERDA	487	LEFT DIVISION
488	DIVISÃO DIREITA	488	DIVISIÓN DERECHA	488	RIGHT DIVISION
489	COSTA	489	RESPALDO	489	BACK
490	BASE	490	BASE	490	BASE
491	TAMPO	491	TAPA	491	TOP
492	TAMPO INTERMEDIÁRIO	492	TAPA INTERMEDIARIA	492	INTERMEDIATE TOP
493	TAMPO GAVETA	493	TAPA CAJÓN	493	DRAWER TOP
494	PRATELEIRA	494	ESTANTE	494	SHELF
496	PRATELEIRA MOVEL	496	ESTANTE MOVIL	496	MOVABLE SHELF
497	MOLDURA MENOR	497	MOLDURA MENOR	497	SMALLER FRAME
498	RODAPÉ	498	ZÓCALO	498	SKIRTING BOARD
500	COSTA DE GAVETA	500	RESPALDO CAJÓN	500	DRAWER BACK
501	PILASTRA	501	PILASTRA	501	DOOR STOP
502	FRENTE DE GAVETA	502	FRENTE CAJÓN	502	FRONT DRAWER
503	PORTA	503	PUERTA	503	DOOR
504	FUNDO DE GAVETA	504	FONDO CAJÓN	504	BOTTOM DRAWER
506	TRAVESSA	506	TRAVIESA	506	CROSS BAR
534	TRAVESSA MAIOR	534	TRAVIESA MAYOR	534	LARGE CROSS BAR
535	TRAVESSA MENOR	535	TRAVIESA MENOR	535	SMALL CROSS BAR
536	PRATELEIRA SUPERIOR	536	ESTANTE SUPERIOR	536	UPPER SHELF
556	LATERAL GAVETA DIREITA	556	LATERAL CAJÓN DERECHA	556	RIGHT DRAWER SIDE
5461	TUBO	5461	TUBO	5461	TUBE
5088	PERFIL I 2040 MM	5088	PERFIL I 2040 MM	5088	I PROFILE 2040 MM
9304	PERFIL I 525 MM	9304	PERFIL I 525 MM	9304	I PROFILE 525 MM

PRÉ-MONTAGEM / PRÉ-ARMADO / PRÉ-ASSEMBLAGE

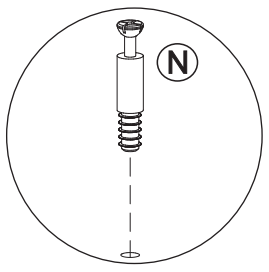
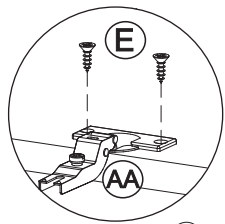

Passo
Paso
Step
07

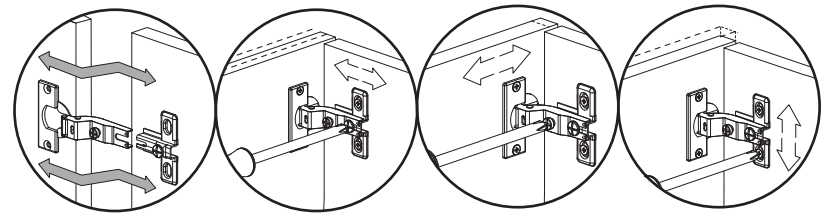
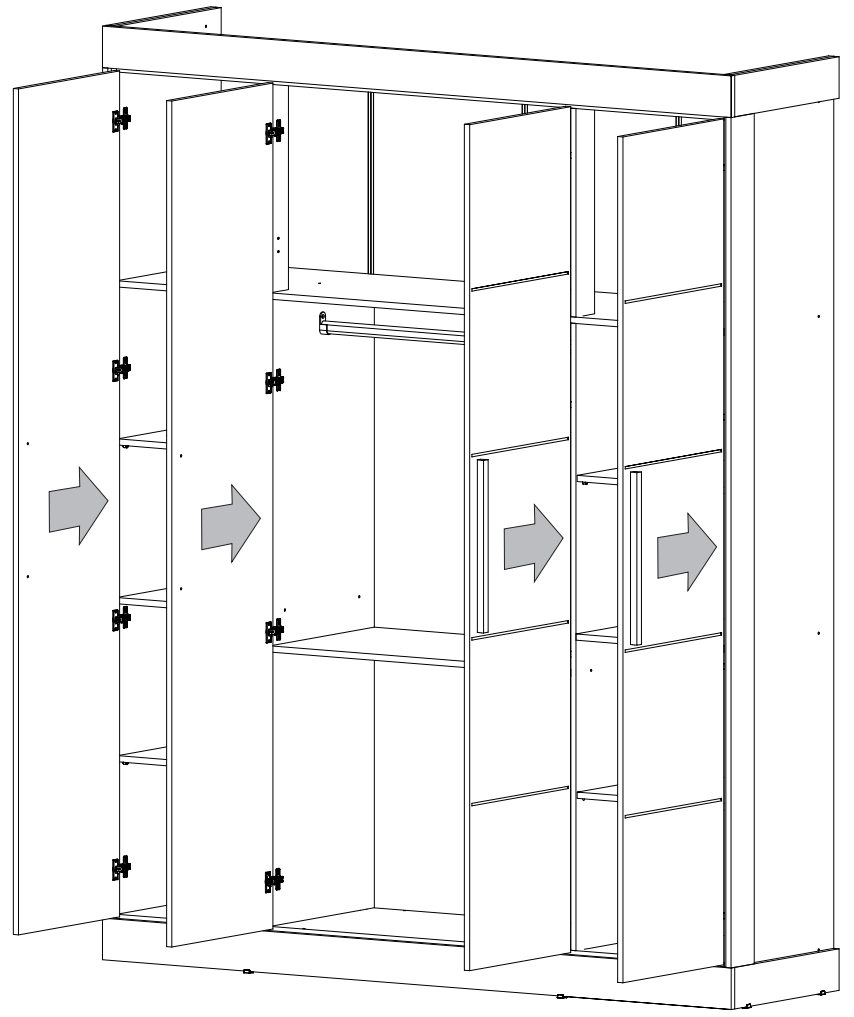
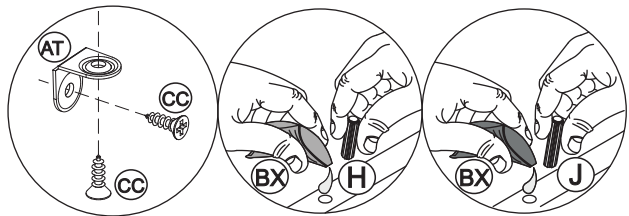
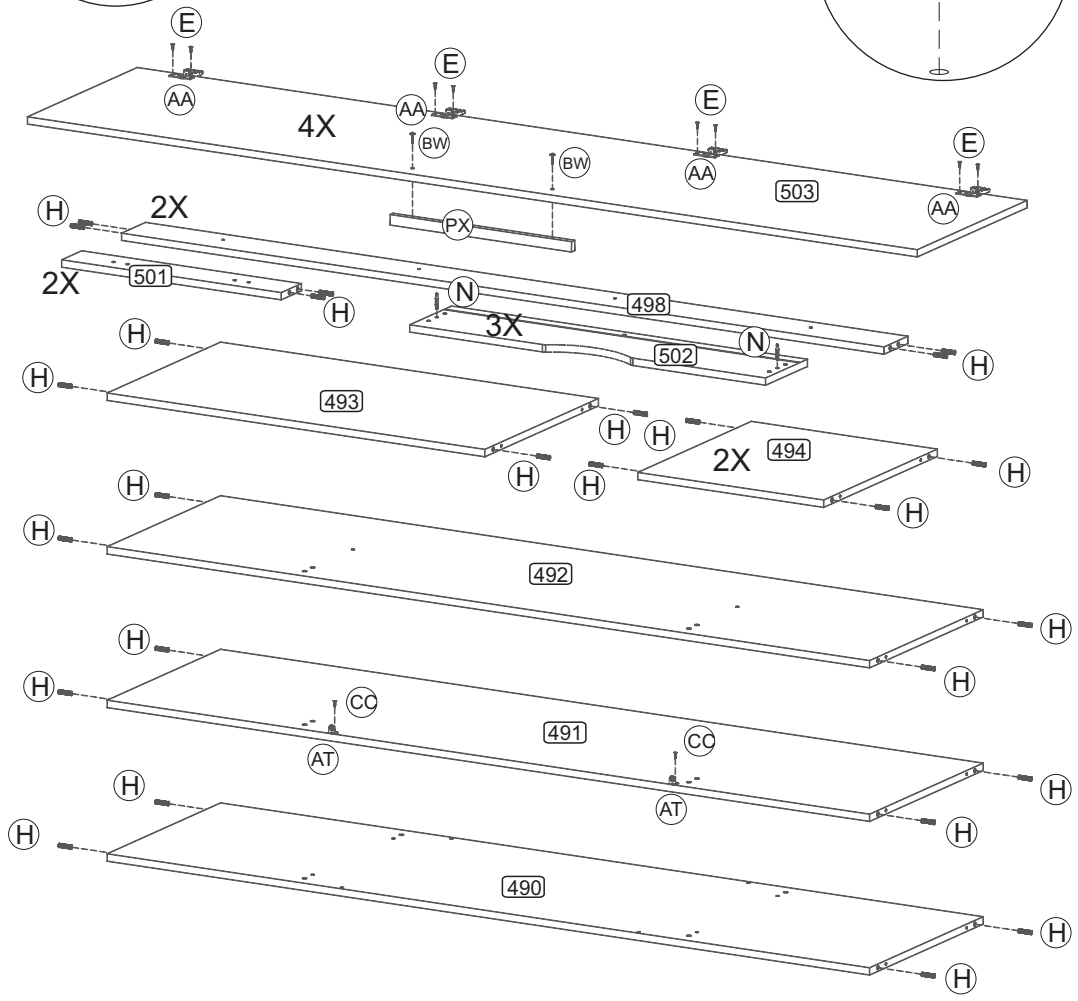

COBRIR OS PARAFUSOS

TAMPA ADESIVA
TAPA ADESIVA
STICKER

TAPA LOS TORNILLOS / COVER THE SCREWS

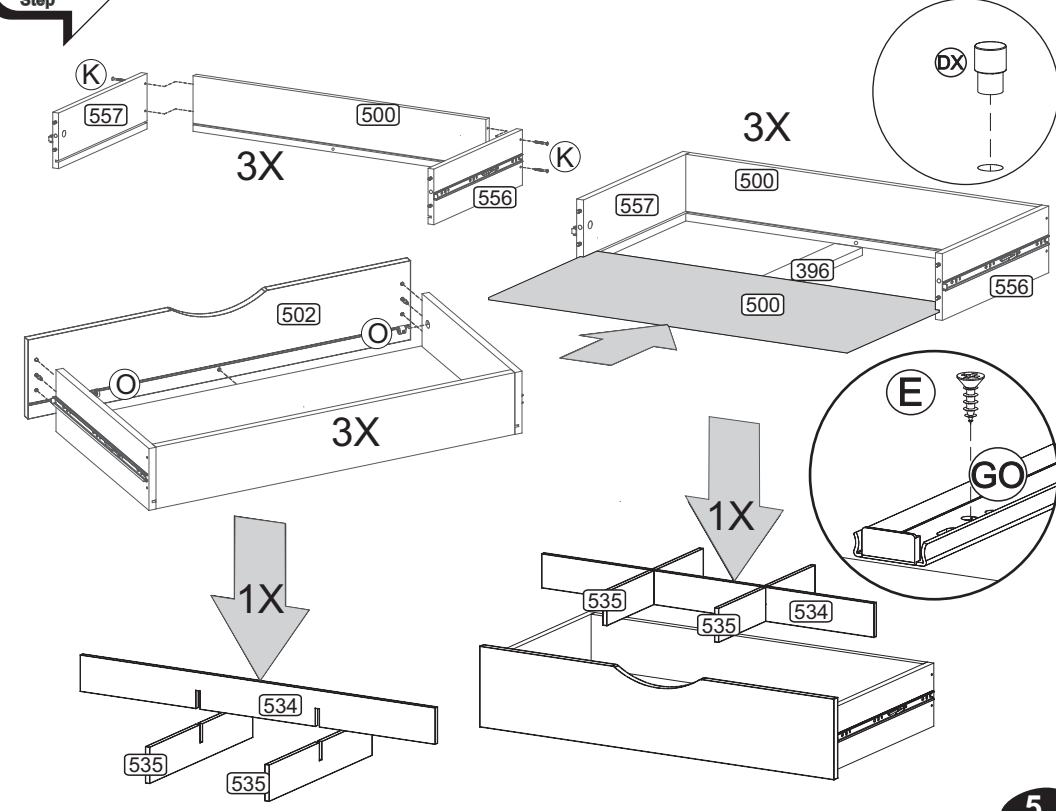
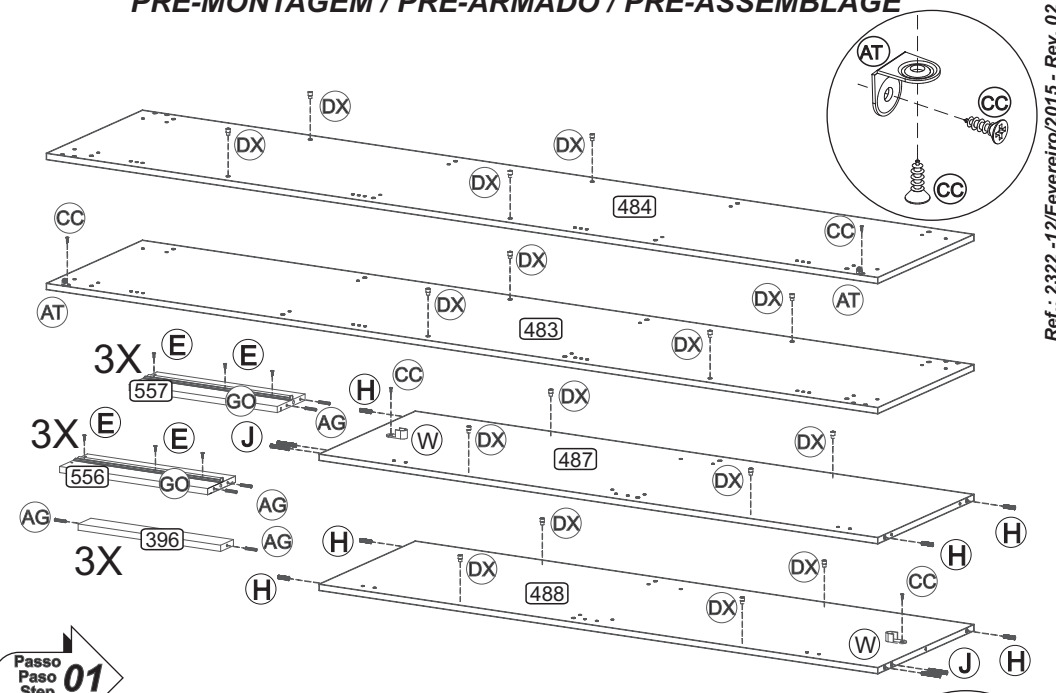
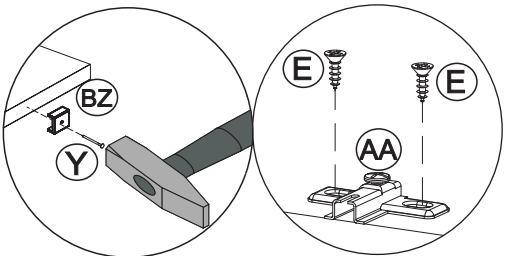
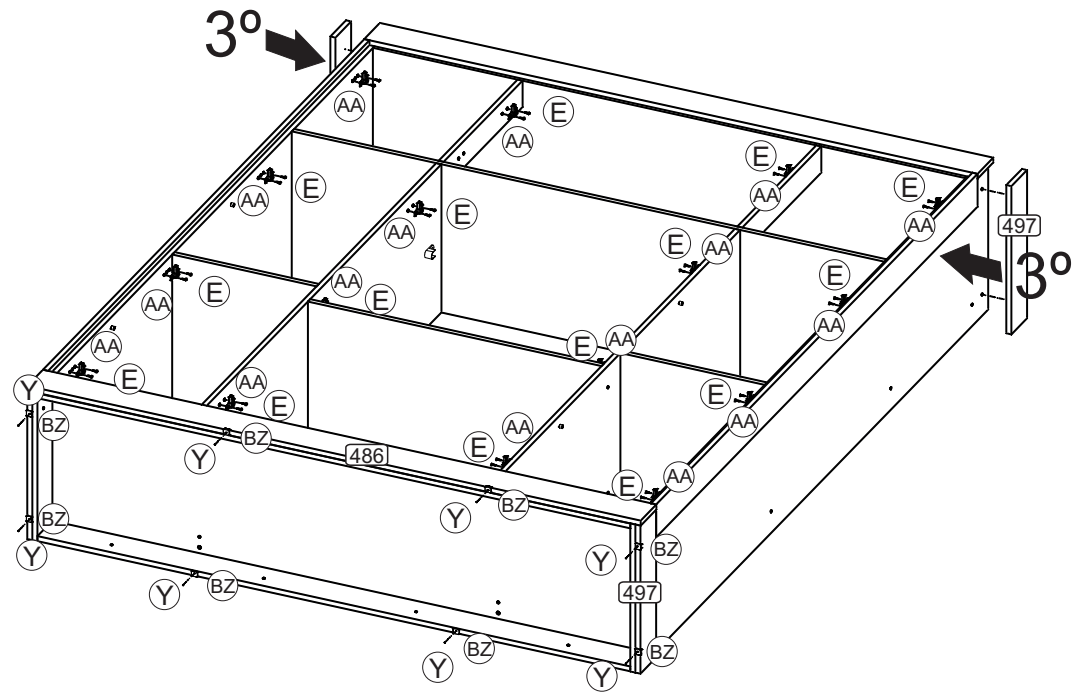

Passo
Paso
Step
02

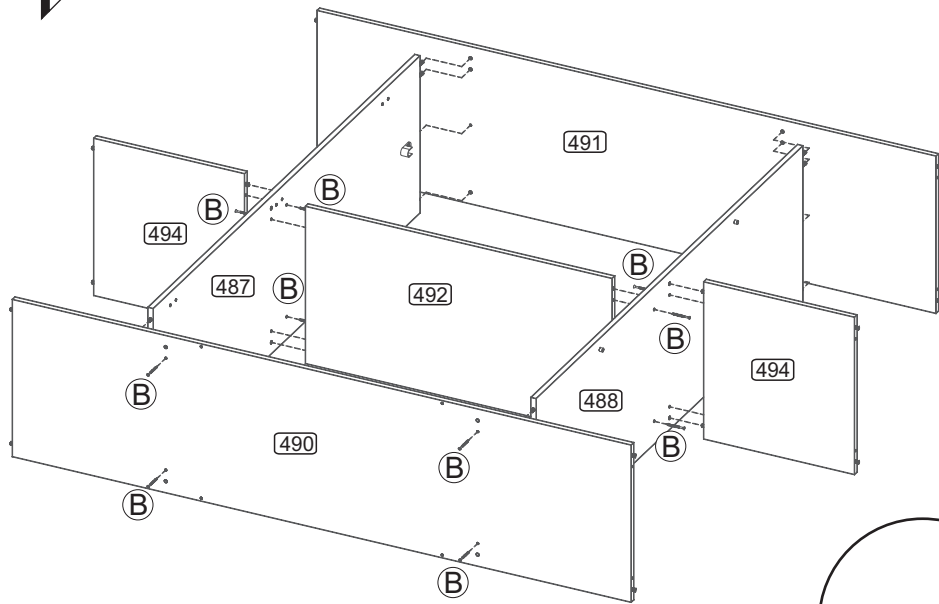

Passo
Paso
Step
03

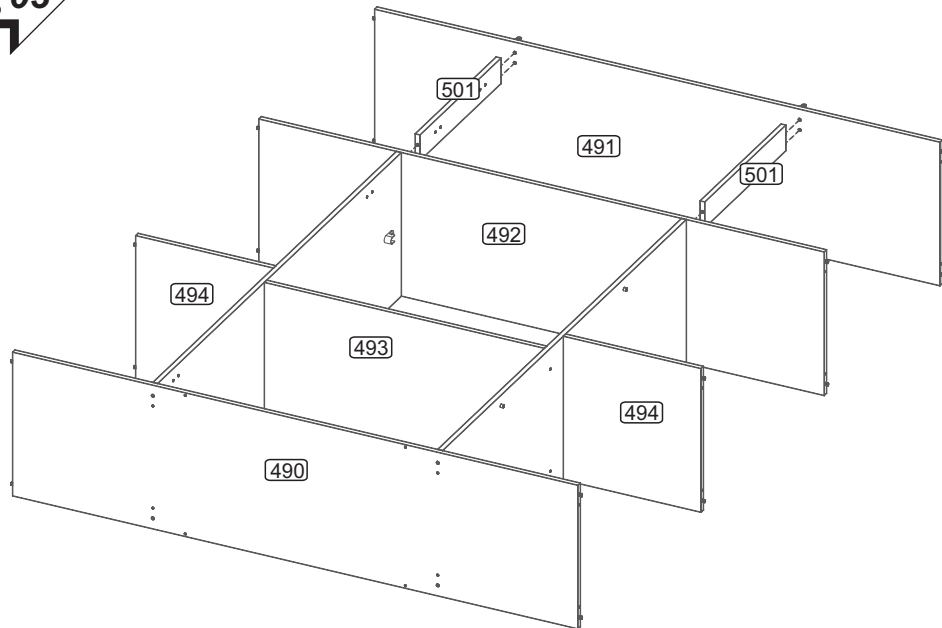

Passo
Paso
Step
04

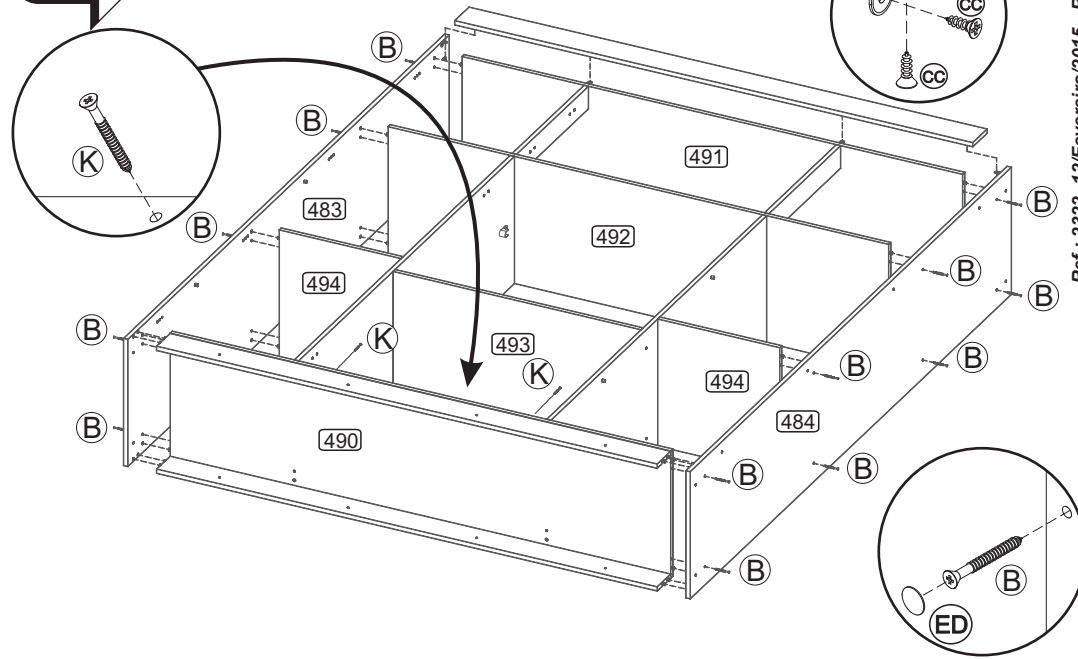

Passo
Paso
Step
05

