

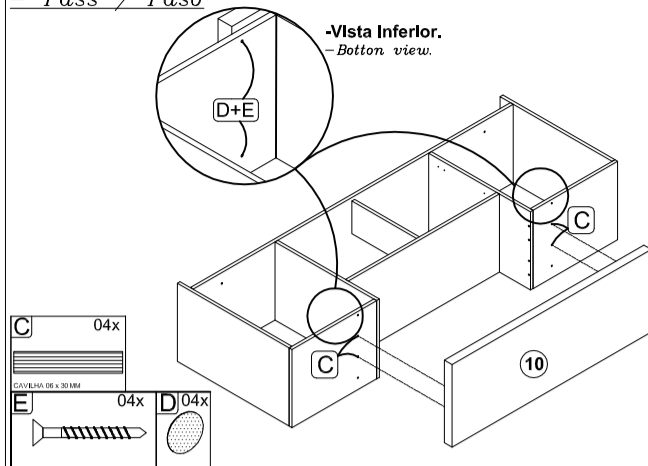

# Sequência de montagem - Assembly Sequence - Secuencia de ensamble.

## - 4º Passo

- Pass / Paso



## - 5º Passo

- Pass / Paso

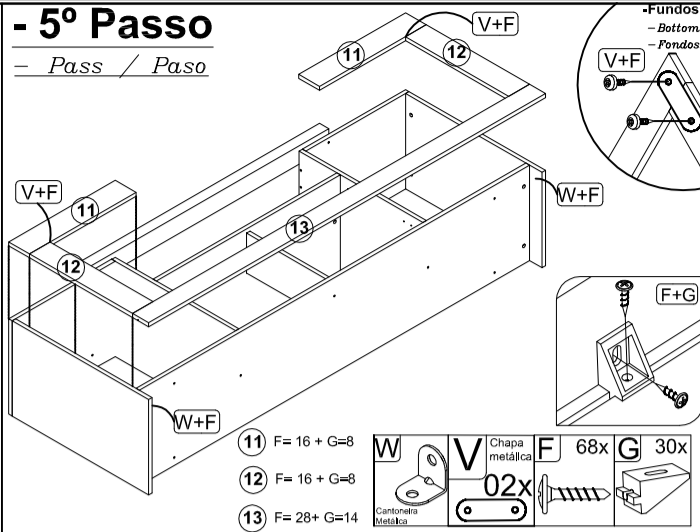

## - 6º Passo

- Pass / Paso

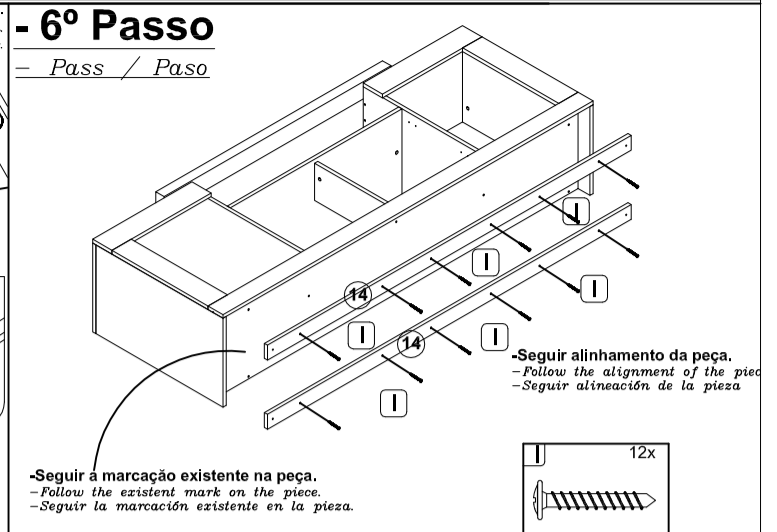

## - 7º Passo

- Pass / Paso

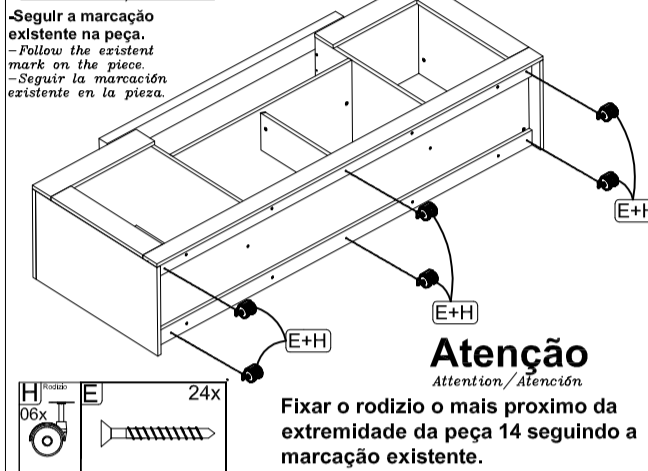

## - 8º Passo

- Pass / Paso

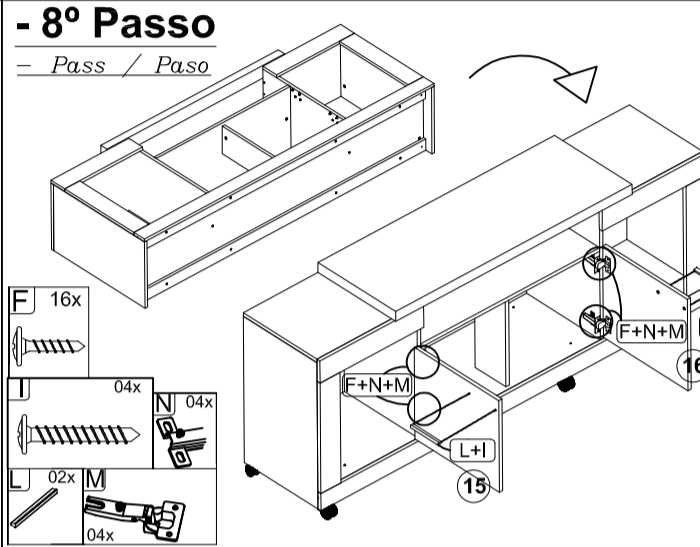

## - 9º Passo

- Pass / Paso

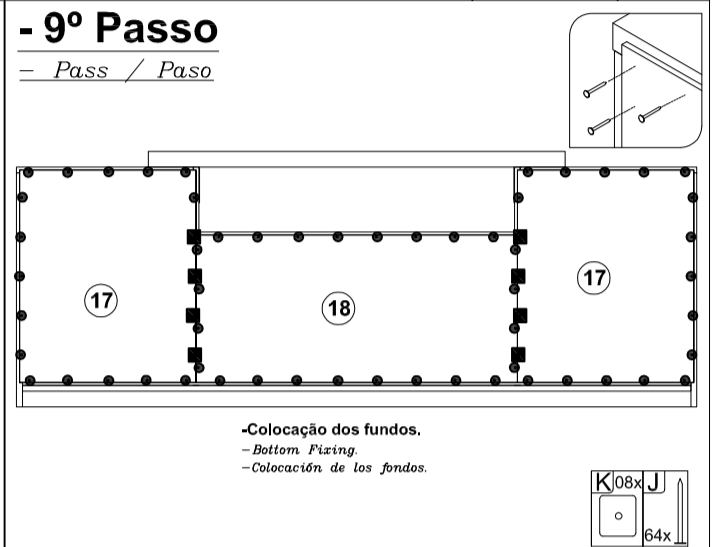

## - 10º Passo

- Pass / Paso

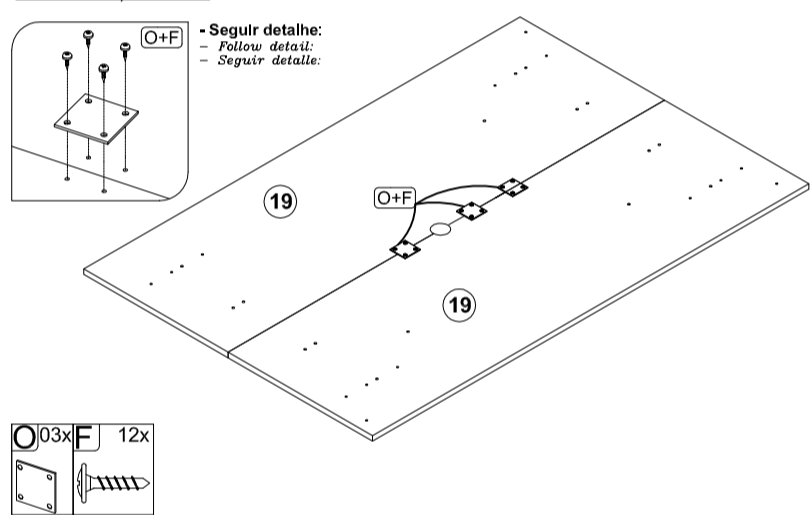

## - 11º Passo

- Pass / Paso

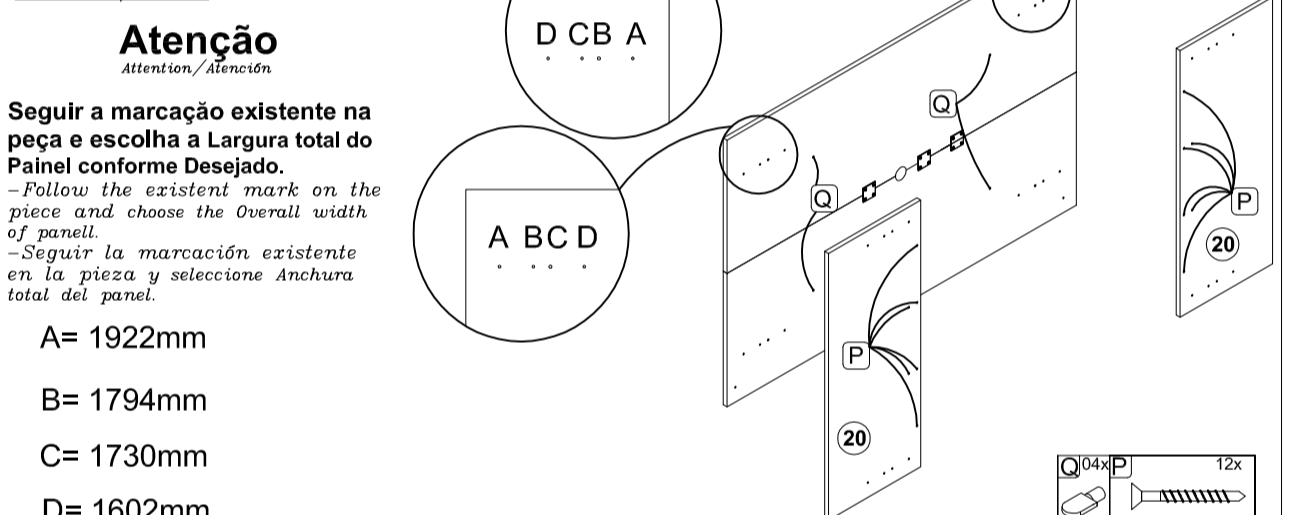

## - 12º Passo

- Pass / Paso

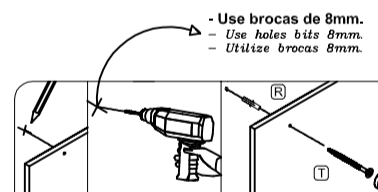
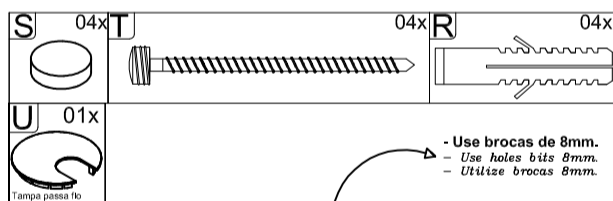
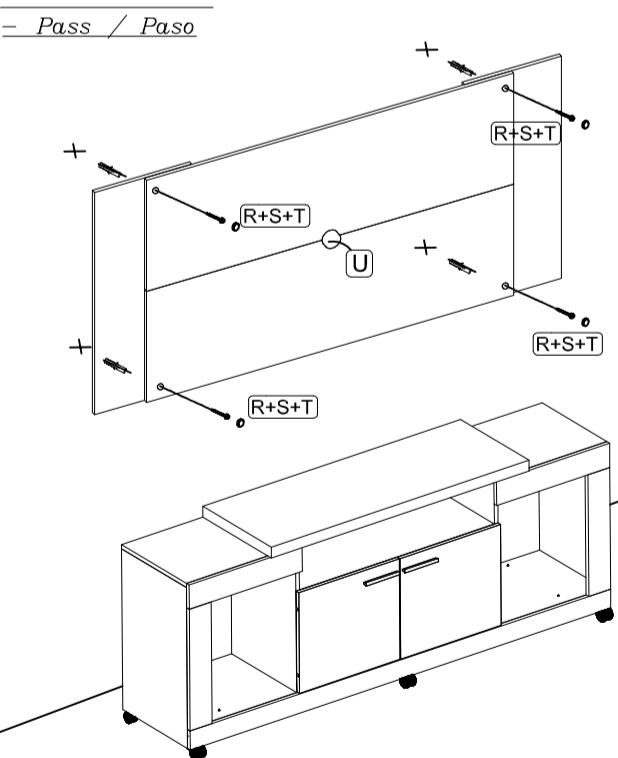

## INSTRUÇÕES

Instruccions / Instrucciones

- Marque os furos na parede conforme mostra o detalhe para determinar a altura do painel.
- Utilize a furadeira para fazer os furos nos lugares marcados. Ao todo serão feitos 04 furos na parede.
- Coloque as buchas plásticas nos furos e utilize os parafusos conforme o desenho.

- Mark holes in the wall as shown in detail for determining the height of the panel.
- Use the drill to make the holes at the marked locations. Altogether 04 holes are made in the wall.
- Place the plastic bushings in the holes and use the screws according to the drawing.

- Como agujeros en la pared como se muestra en detalle para determinar la altura del panel.
- Use el taladro para hacer los agujeros en los puntos marcados. En total 04 agujeros se hacen en la pared.
- Colocar los casquillos de plástico en los agujeros y utilice los tornillos de acuerdo con el dibujo.

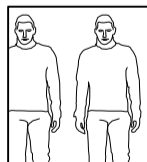

- Recomendamos que esta etapa da montagem do produto seja feita por 02 pessoas.
- Recommend that the assembly the product is made by 02 persons.
- Recomendamos que la ensamble del producto se haga por 02 personas.

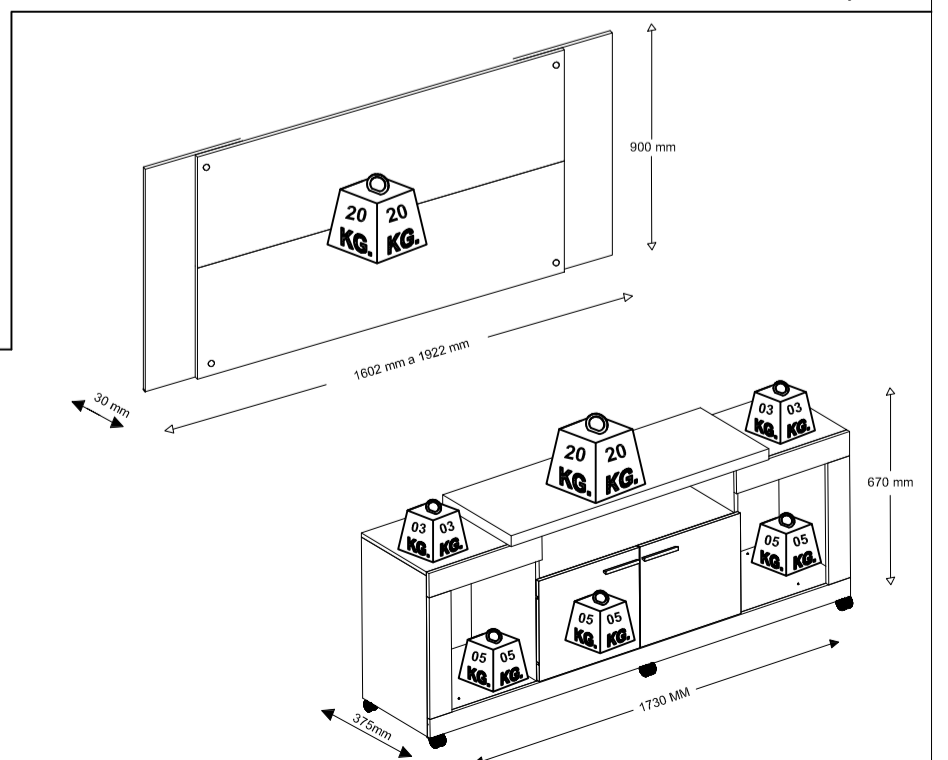

## - Aspecto Final

- Final Aspect

- Imagem ilustrativa do aspecto final do produto.
- Illustrative image of the product final aspect.
- Objetos decorativos não inclusos.
- Ornaments not included.
- Decoración no incluida.

