

**MONTAGEM  
MONTAJE  
ASSEMBLING**

4°

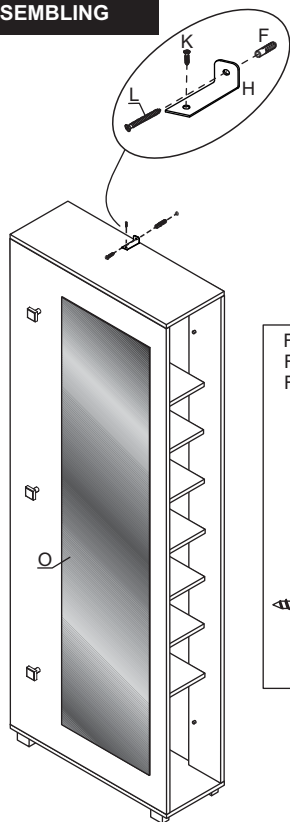

5°

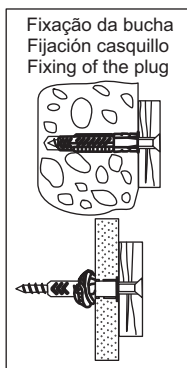
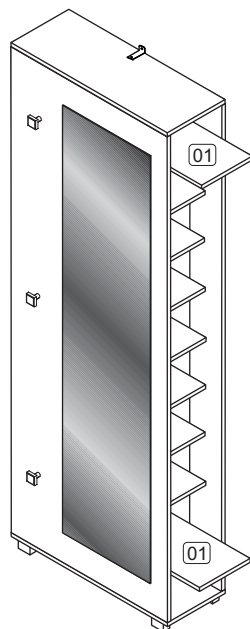

Obs: Prateleiras móveis (1) podem ser retiradas para colocação de botas cano longo.

Obs.: Estanterias móviles (1) pueden ser removidas para colocación de botas de cañón largo.

Note: Stands mobile (1) can be set aside for the placement of long-barreled boots



# BST11



Ferramentas necessárias  
(não fornecidas)  
Herramientas necesarias  
(no se incluye con el producto)  
Needed tools  
(not included)



**Peso Máximo suportado pelo produto**  
**Peso Máximo suportado por el producto**  
**Product weight limit**



**20 PARES DE SAPATO**  
**20 PARES DE ZAPATO**  
**20 PAIRS OF SHOES**

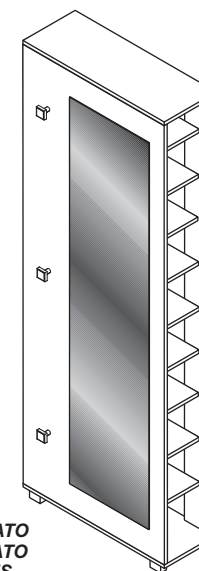

**Atenção!**

1. Parabéns, você está adquirindo um produto com a qualidade BRV Móveis.
2. Antes de iniciar a montagem leia e observe severamente este manual.
3. **IMPORTANT!** Para que o produto não perca a garantia, solicitamos observar atentamente as orientações de montagem como: fixação do produto na parede, colocação de cola em locais específicos necessários, o peso suportado pelo produto, etc...
4. Caso não sinta segurança em realizar a montagem deste produto, contrate um profissional capacitado.
5. Aconselhamos utilizar embalagem para forrar o chão, afim de não danificar o produto.

**Limpeza:**

1. Pano levemente umedecido com água, seguido de pano seco.
2. Não utilizar produtos químicos ou abrasivos.

**Atención!**

1. Felicitaciones, usted está recibiendo un producto de calidad BRV Muebles.
2. Antes de comenzar el montaje, le a estas instrucciones cuidadosamente.
3. **IMPORTANT!** Para que el producto no perda la garantía, pedimos que le atentamente las instrucciones, principalmente la fijación del producto em una pared, colocación de cola em local especific y necesario, el peso suportado por el producto etc...
4. Si usted no se siente seguro em hacer el montaje deste produto, póngase em contacto com um professional.

**Limpeza:**













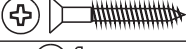

1. Solamente usar um paño húmedo y jabón neutro.
2. No utilice produtos químicos o abrasivos.

**Attention!**

1. Congratulations, you're acquiring a product with BRV Móveis quality.
2. Before starting to assemble the product, read and observe carefully this manual.
3. **IMPORTANT!** In order to keep the guarantee of the product we request to carefully observe the guidances like: fixing the product on the wall, adding glue in needed and specified places, product weight limit, etc.
4. In case you don't feel confident to assemble this product, contact a professional to do the job.
5. We advise to use the package to protect the floor in order to prevent damages.

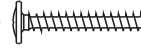
**Cleaning:**

1. Slightly dampened cloth and after a dry cloth.
2. Do not use chemicals or abrasives.

Ferragens/Herrajes/Ironmongery (mm)	QTD.	Ferragens/Herrajes/Ironmongery (mm)	QTD.
A  8x30	38	I  03	
B  3,5x40	16	J  3,5x25	08
C  09		K  3,5x14	01
D  02		L  5,0x50	01
E  02		M  04	
F  Ø8mm	01	N  3,5x30	03
G  8x7	08	O  Espelho Espejo	01
H  01			

COD	Descrição/Descripción/Description	QTD.	mm	in
1- 4996	Prateleira Móvel/Estante Móvil/Mobile Shelf	02	535x219x15	21.1x8.62x0.59
2- 4997	Prateleira/Estante/Shelf	06	535x219x15	21.1x8.62x0.59
3- 4998	Prateleira Central/Estante del Medio/Central Shelf	01	535x219x15	21.1x8.62x0.59
4- 4999	Tampo_Base/Tapa_Base/Top_Base	02	675x250x15	26.6x9.84x0.59
5- 5000	Costa/Revés/Back	02	138x1820x15	5.43x71.7x0.59
6- 5001	Painel Frontal/Panel Delantero/Front Panel	01	675x1820x15	26.6x71.7x0.59

**PRÉ-MONTAGEM  
FASE DE PREPARACIÓN  
DE LAS PIEZAS  
PRE-ASSEMBLING**

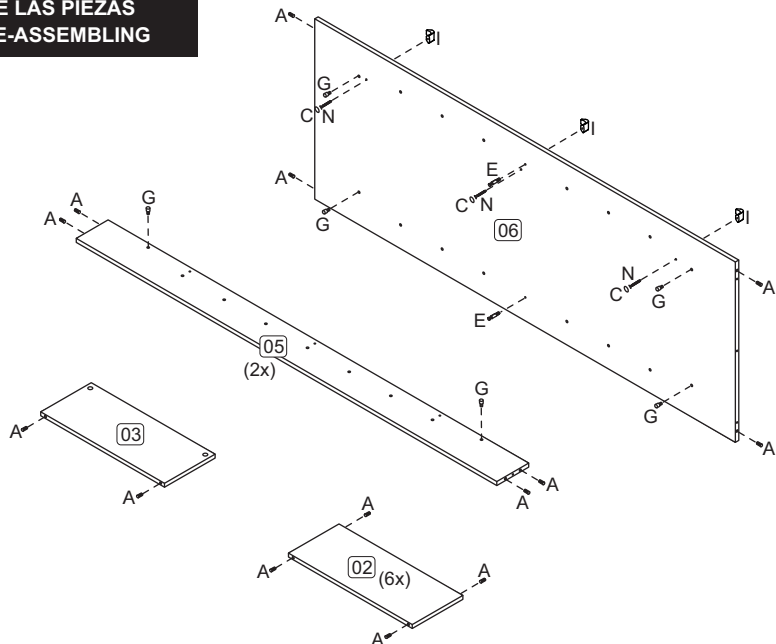

**MONTAGEM  
MONTAJE  
ASSEMBLING**

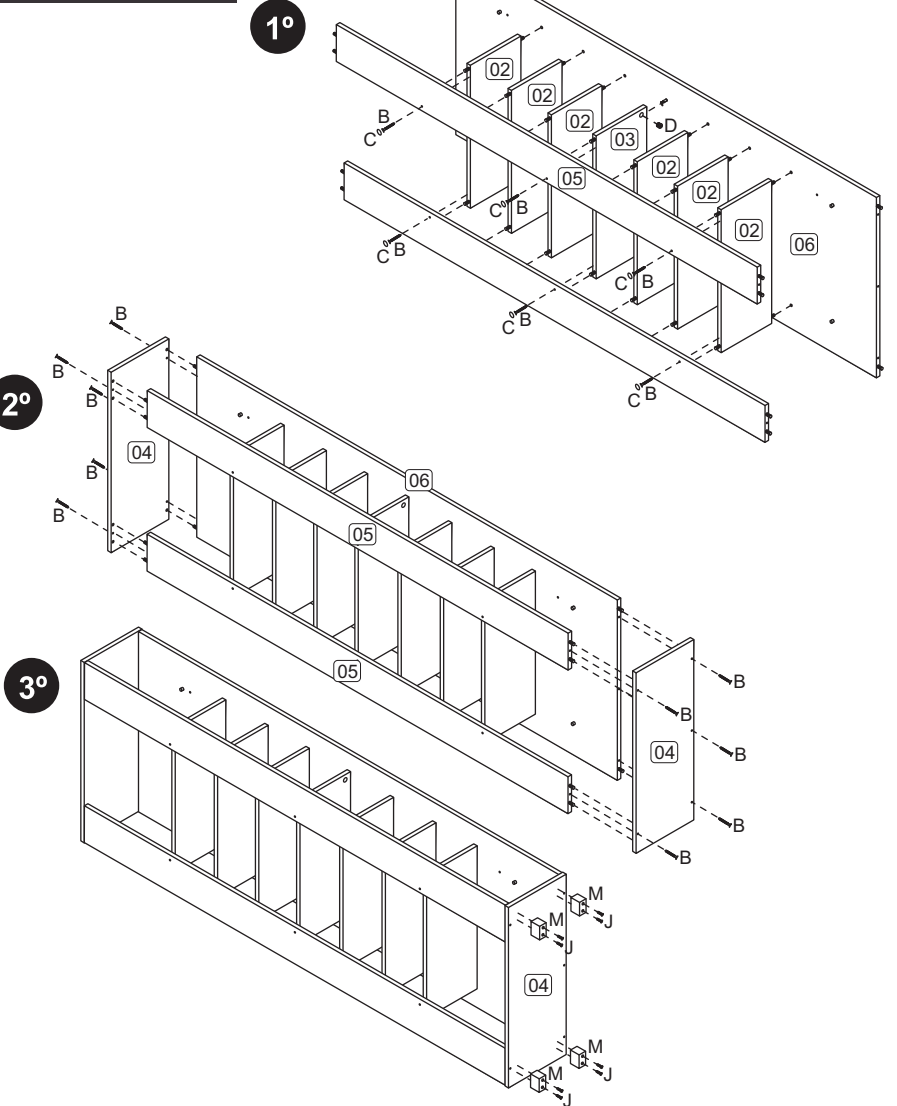

Garantia (exclusivo para o Brasil/exclusivo de Brasil/exclusive to Brazil):  
A garantia dos produtos fabricados pela BRV Móveis, abrange eventuais defeitos-  
vícios de fabricação, no prazo estabelecido pelo Código de Defesa do Consumidor,  
em seu artigo 26,II, o qual prevê a garantia legal de 90 (noventa) dias.

