

SERPIL

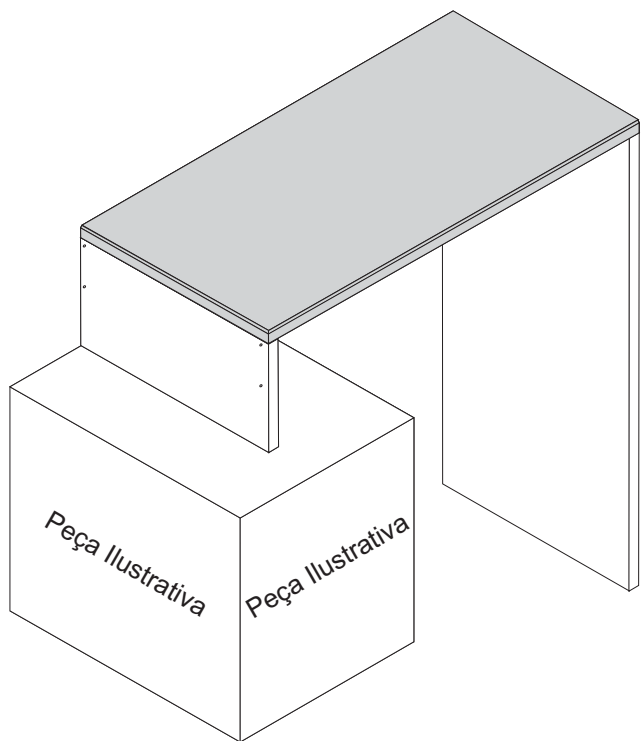

DUO

Escrivaninha

Bem-vindo

A Serpil traz até você soluções práticas de design com manuais de montagem e instalação detalhados para possibilitar o pleno aproveitamento do potencial dos produtos.

Para assegurar a garantia, é recomendada a prévia conferência de partes e componentes, bem como a leitura dos passos e suas ilustrações.

Preservar este documento é essencial para a adequada manutenção de seu móvel, o que engloba os possíveis ciclos de montagem e desmontagem.

Em caso de dúvidas, contate a Serpil que atende pelo fone 49.3366.6300 de Segunda a Sexta, das 7:30 às 11:45 e 13:30 a 18:00.

Recomendações

Para a montagem deste produto, são necessárias 2 pessoas.

Os parafusos devem ser apertados periodicamente.

Evitar batidas e o contato com objetos cortantes.

Observar as cargas máximas suportáveis, quando houver, conforme o desenho esquemático no final do documento.

Partes do produto protegidas da incidência de luz estão sujeitas a alterações de tonalidade diferentemente das expostas. Somente o uso freqüente pode amenizar esta ocorrência.









Algumas pinturas novas, embora atóxicas, podem apresentar odores. Para amenizá-los, mantenha o móvel em local arejado por aproximadamente três dias.

Manutenção e Limpeza

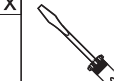
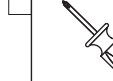
Pano levemente umedecido com água, seguido de pano seco.

*Nunca utilizar produtos químicos ou abrasivos.

Abaixo sinalizadas, as ferramentas não fornecidas mas necessárias para a montagem do produto.

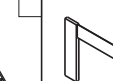
 X	 X	 X			
		 X			

Partes do Produto

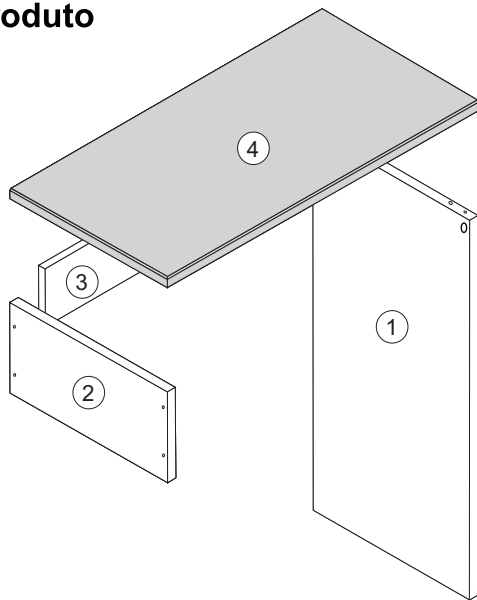

DESCRIÇÃO	COMP.	LARGU.	ESPESS.	CÓDIGO
1 Lateral Dir. Escrivaninha DUO	715	425	25	5173-0
2 Lateral Esq. Escrivaninha DUO	195	425	25	5173-1
3 Regua Escrivaninha DUO	784	150	21	5173-2
4 Tampo Escrivaninha DUO	860	430	25	5173-3

Componentes



A- Sachet Cola 10g (1x)



B- Cavilha
8 x 30mm (4x)



C- Minifix Rápida
(4x)



D- Tambor Minifix
(4x)



E- Feltro
25 x 25mm (4x)



F- Parafuso Soberbo
5 x 60mm (4x)

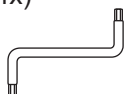

G- Chave Zeta
Ø 3 mm (1x)

Pré-Montagem

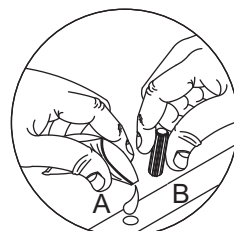
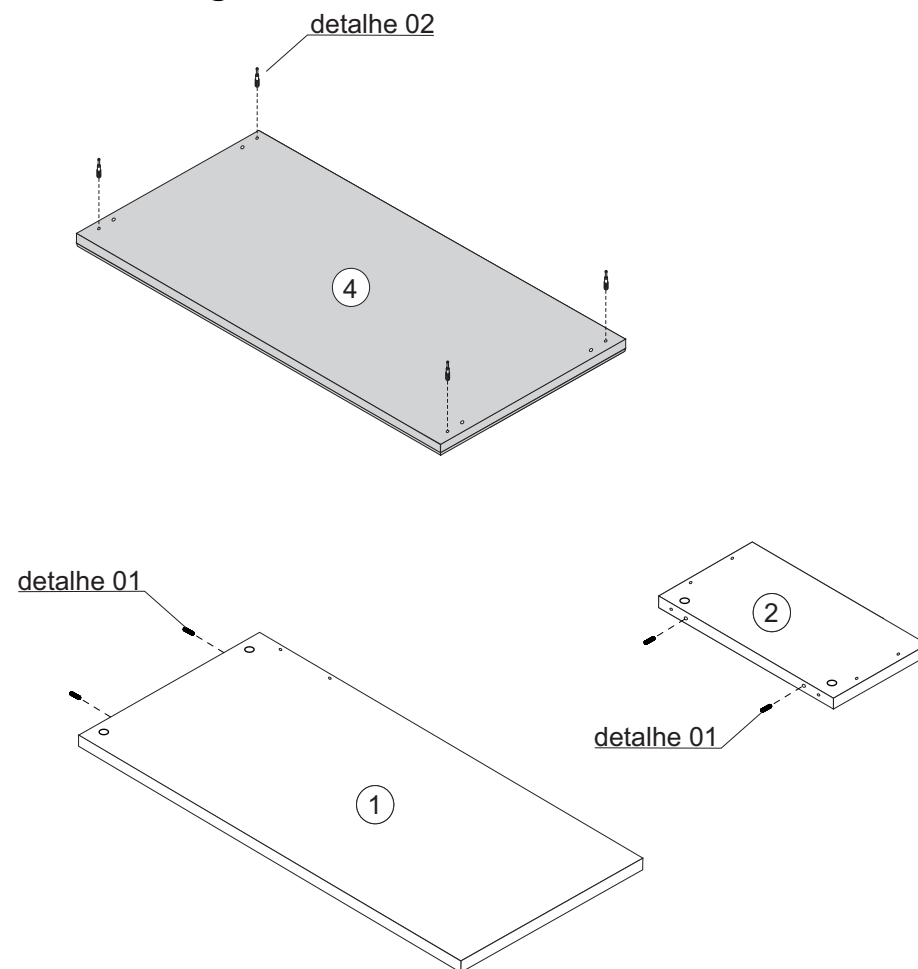

detalhe 1

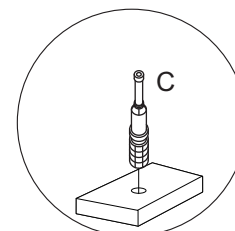

detalhe 2

1

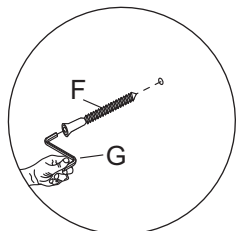
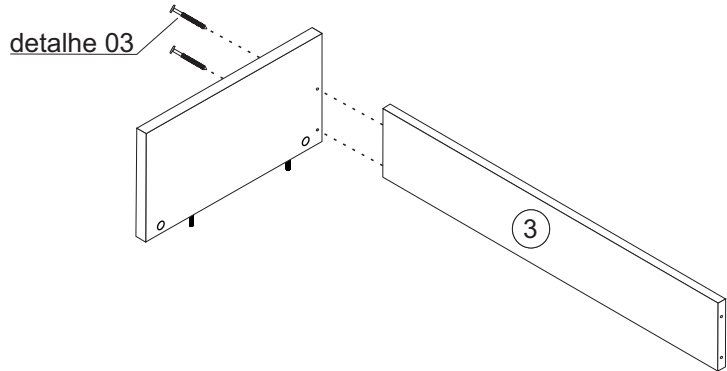
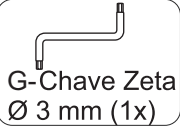
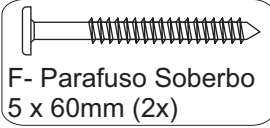

detalhe 3

2

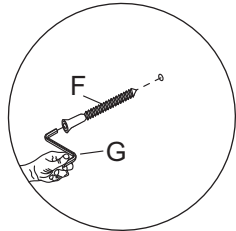
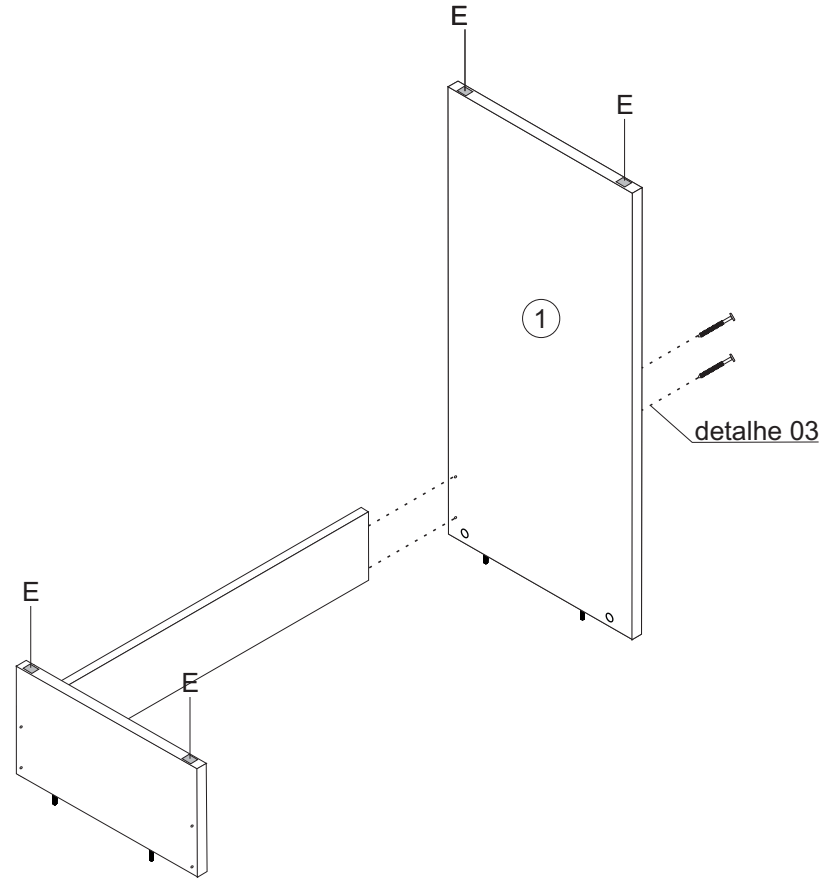
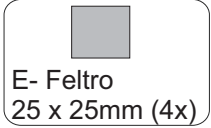
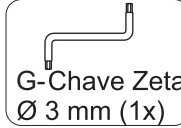
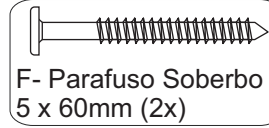

detalhe 3

3



D- Tambor Minifix
(4x)

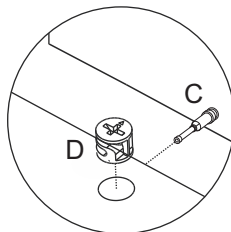
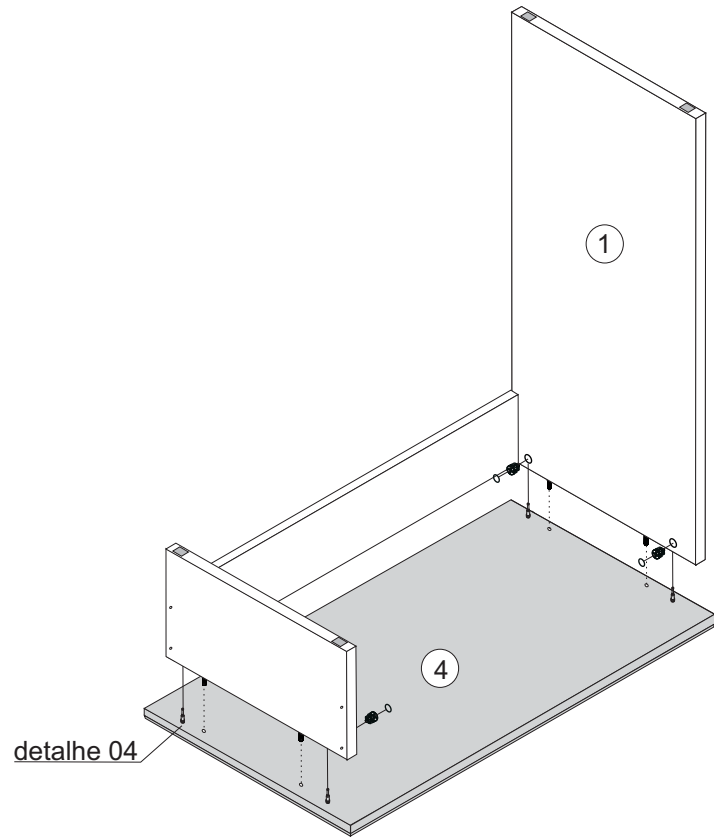

detalhe 4

Capacidade de Carga

