

MANUAL DE MONTAGEM
Assembly instructions / Instrucciones de armado

BELICHE LINS

Bunk Bed Lins
Litera Lins

Código 2365 | Revisão 02

NOTA: Este produto pode ser montado para a sua esquerda ou direita.
NOTE: This product can be assembled to the left or to the right.
NOTA: Este producto se puede armar para la izquierda o para la derecha.

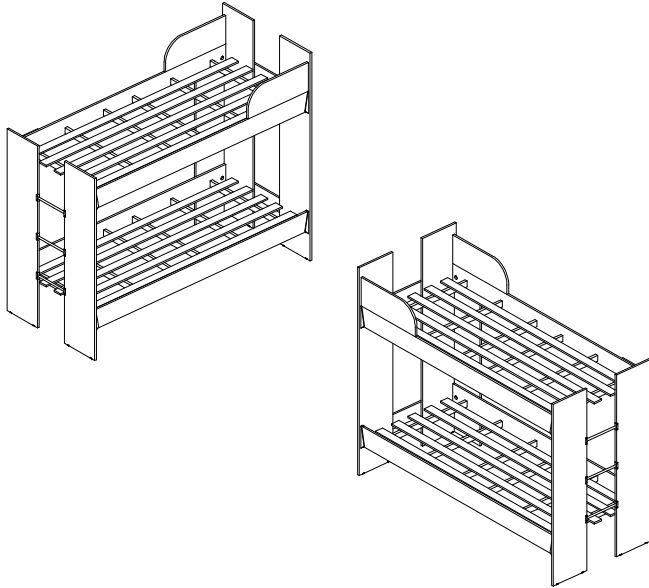

PESO MÁXIMO SUPORTADO PELAS PEÇAS, SENDO ESTE DISTRIBUÍDO UNIFORMEMENTE.
Maximum weight supported by parts, being this evenly distributed.
Peso máximo soportado por las partes, siendo esta distribuido uniformemente.

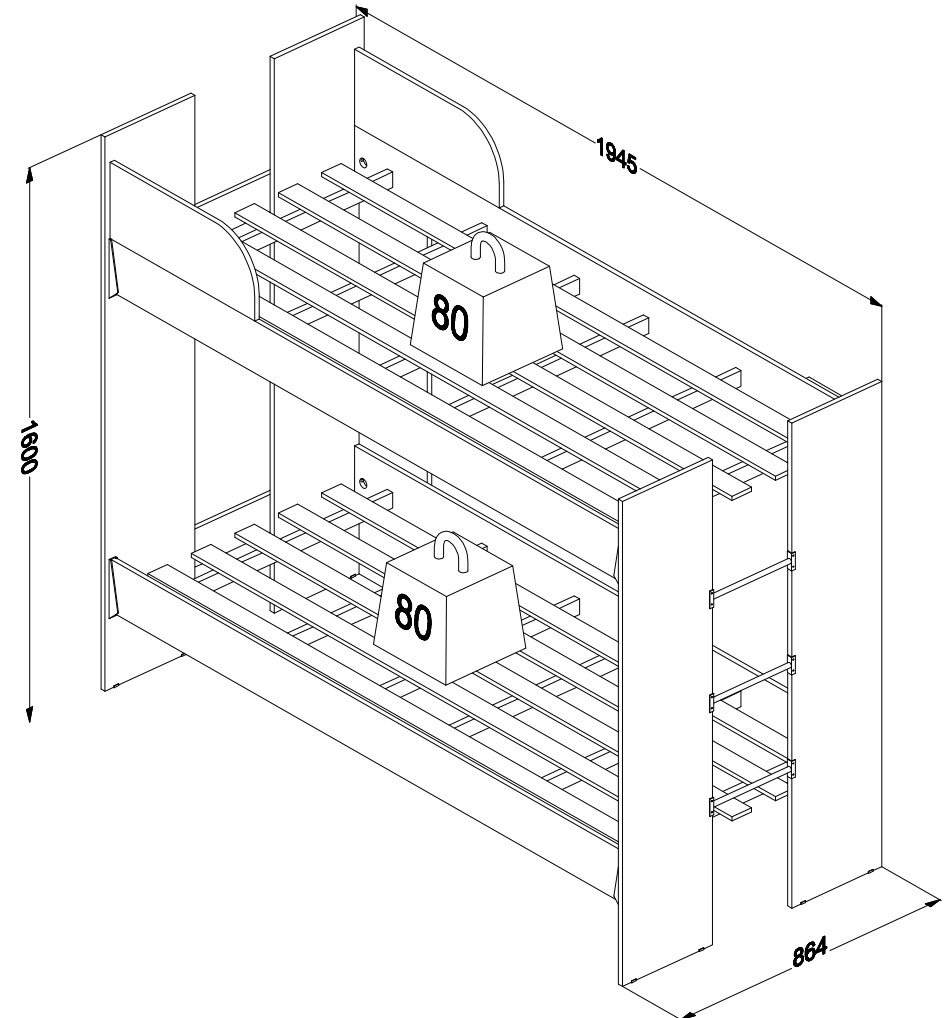

Você vai precisar de/ You will need / Usted necesitará

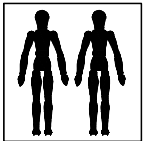

2 Pessoas
2 people
2 personas

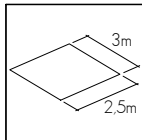

Espaço recomendado para montagem
Recommended space for assemble
Espacio recomendado para el armado

Ferramentas não inclusas
Tools not included / Herramientas no incluidas

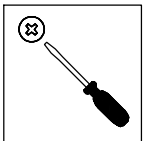

Chave Philips
Screwdriver
Destornillador cruz

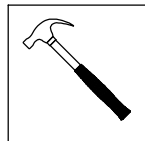







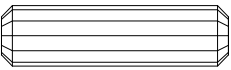

Martelo
Hammer
Martillo

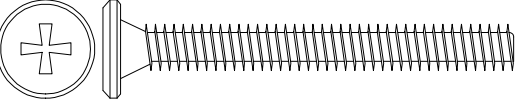
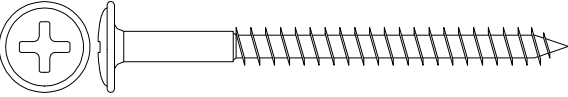
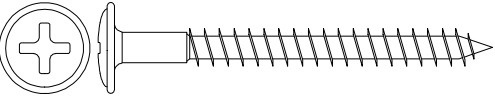
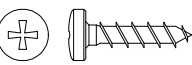
* PESO EM KG/ Weight in Kg/ Peso en Kg
DIMENSÕES EM MM/ Dimensions in mm/ Dimensiones en mm

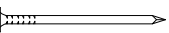
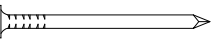
IDENTIFICAÇÃO DOS ACESSÓRIOS/ IDENTIFICATION OF ACCESSORIES/ IDENTIFICACIÓN DE ACCESORIOS

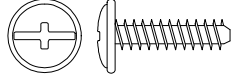
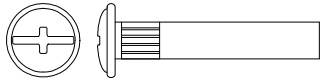
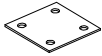
NOTAS: A separação dos acessórios antes de iniciar a montagem facilitará a mesma. Os parafusos e cavilhas estão na escala real. Em caso de dúvida na identificação, coloque o acessório sobre a imagem.
NOTES: The separation of the accessories before you start the assembly will facilitate the same. The screws and dowels are in real scale. In case of doubts about the identification, place the accessory on the image.
NOTAS: La separación de los accesorios antes de comenzar el armado facilitará el mismo. Los tornillos y taquetes son en escala real. En caso de dudas sobre la identificación, coloque el accesorio en la imagen.

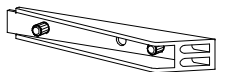
A		Cavilha Wooden Dowel Pin	8x30 mm	12	16		Degrau metálico Metal step Paso de metal	-	03
C		Parafuso Screw Tornillo	6x50 mm	08					
D		Parafuso flangeado Flanged head screw Tornillo de cabeza flangeada	5,0x60 mm	16					
E		Parafuso flangeado Flanged head screw Tornillo de cabeza flangeada	5,0x50 mm	12					
G		Parafuso panela Pan head screw Tornillo de pan	3,5x14 mm	20					
H		Sapata Small plastic foot Pie plástico	15 mm	10					
I		Prego Nail Clavo	10 x10	10					
J		Prego Nail Clavo	12 x12	60					
K		Porca semi-elíptica Semi-elliptic nut Tuerca semielíptico	-	08					
L		Parafuso união "M" Screw union "M" Tornillo de unión "M"	4,0x15 mm	16					
M		Parafuso união "F" Screw union "F" Tornillo de unión "F"	30 mm	16					
N		Junção de tampos Junction of tops União de tapas	-	02					
P		Tampa parafuso Screw cover Tapa tornillo	13 mm	08					
15		Suporte lateral cama Bed lateral support Soporte lateral cama	-	04					

IDENTIFICAÇÃO DAS PEÇAS/ PARTS IDENTIFICATION/ IDENTIFICACIÓN DE LAS PIEZAS

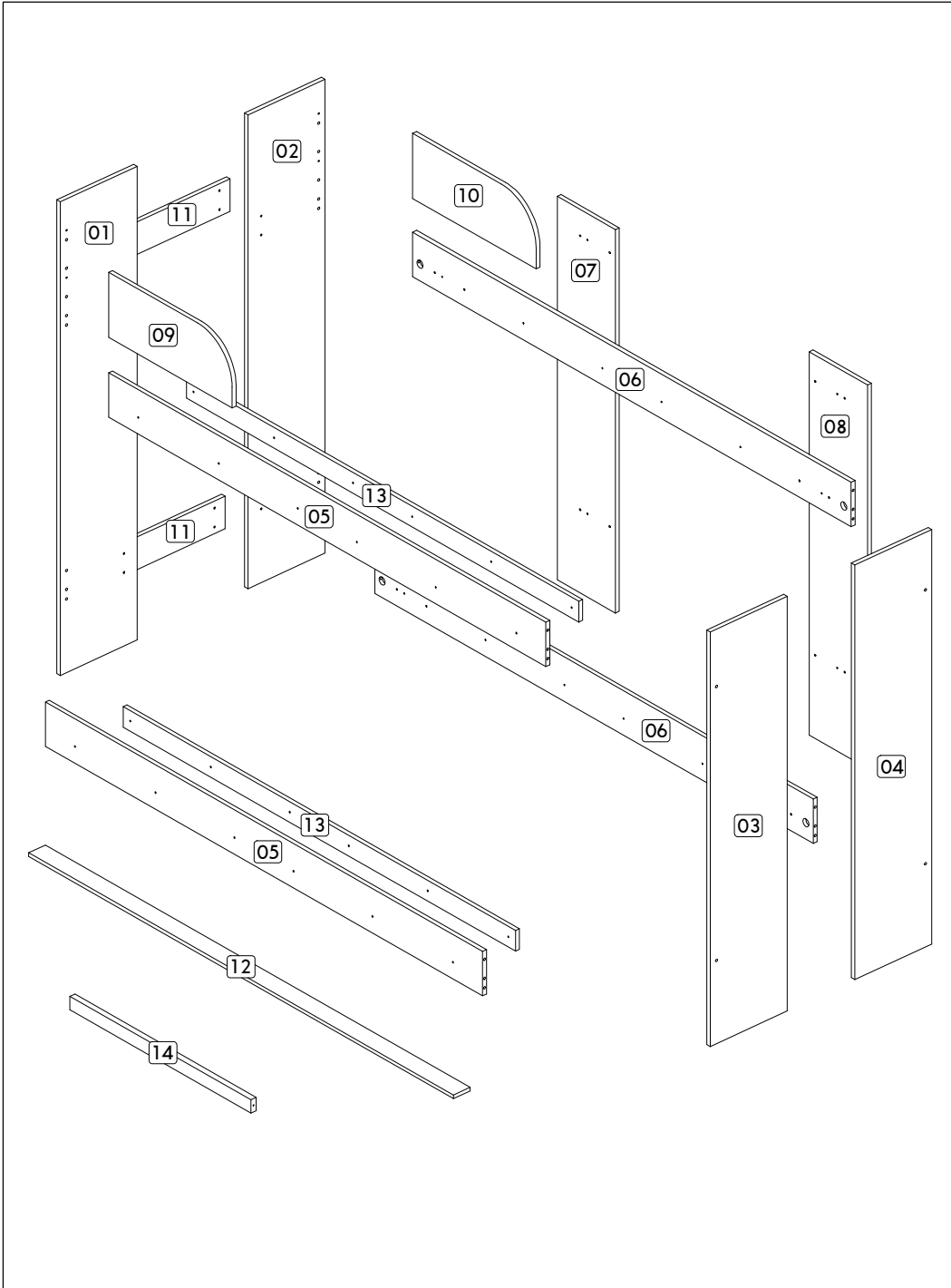

Nº	DESCRIÇÃO - DESCRIPTION - DESCRIPCIÓN	MEDIDAS-MEASURES - MEDIDAS (mm)	QTD.
01	Cabeceira frontal - Front headboard - Cabecera frontal	1600 x 300 x 15	01
02	Cabeceira traseira - Rear headboard - Cabecera trasera	1600 x 300 x 15	01
03	Peseira frontal - Front footboard - Reposapiés frontal	1400 x 300 x 15	01
04	Peseira traseira - Rear footboard - Reposapiés trasero	1400 x 300 x 15	01
05	Lateral de cama frontal - Front bed side - Lateral de cama frontal	1894 x 150 x 15	02
06	Lateral de cama traseiro - Back bed side - Cama lateral parte trasera	1900 x 150 x 15	02
07	Reforço esquerdo - Left reinforcement - Refuerzo izquierdo	1295 x 252 x 15	01
08	Reforço direito - Right reinforcement - Refuerzo derecho	1295 x 252 x 15	01
09	Guarda cama 1 - Bed guard 1 - Guardia cama 1	535 x 220 x 15	01
10	Guarda cama 2 - Bed guard 2 - Guardia cama 2	535 x 220 x 15	01
11	Vista de sustentação - View Support - Vista de sustentación	450 x 110 x 15	02
12	Lastro MDF - MDF ballast - Lastre de MDF	1840 x 65 x 12	10
13	Reforço lateral cama - Bed side reinforcement - Refuerzo lateral de la cama	1700 x 70 x 15	02
14	Travessa - Tray - Traviesa	785 x 45 x 20	12

PRÉ-MONTAGEM/ PRE-ASSEMBLE/ PRE ARMADO

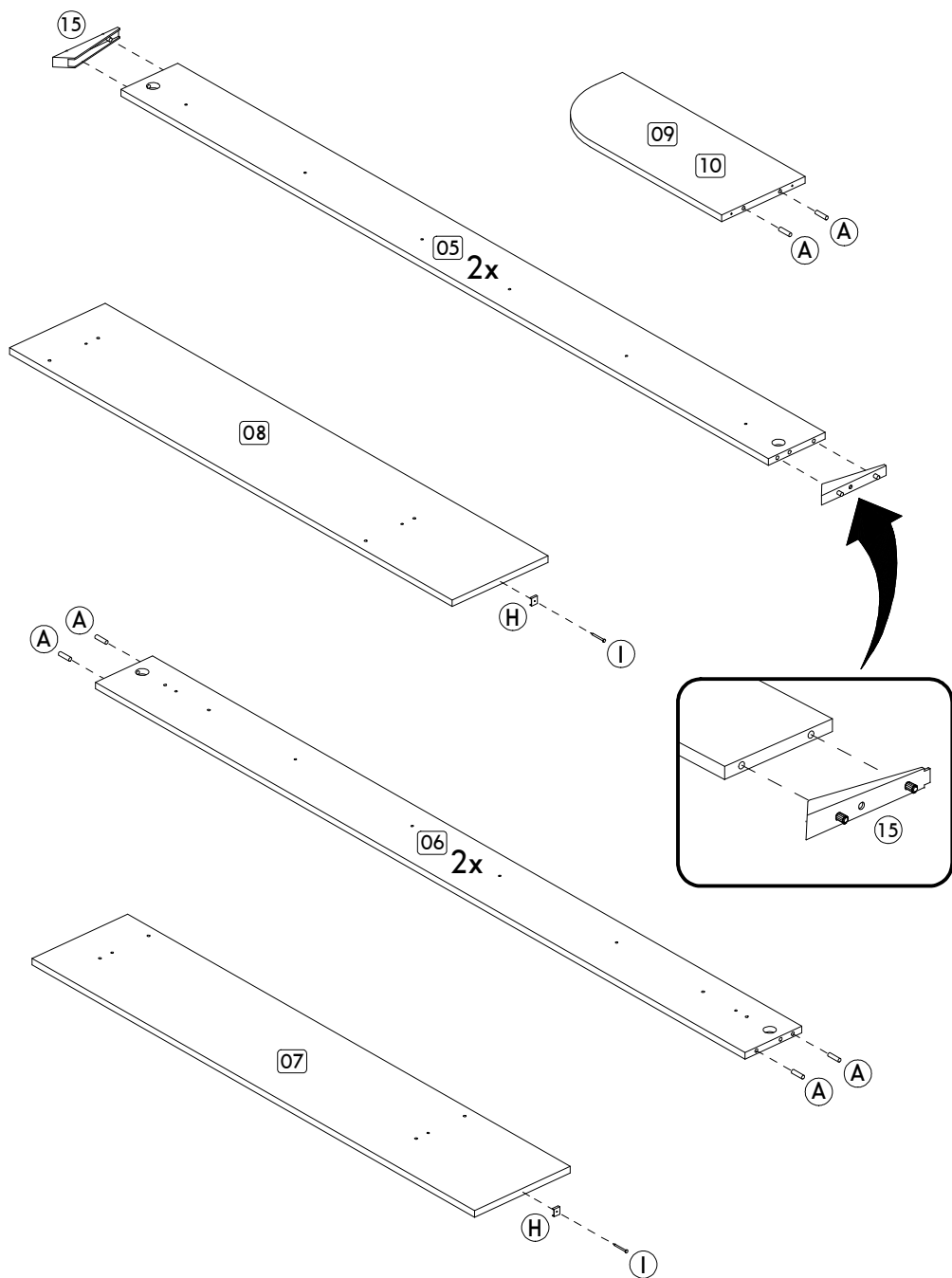

MONTAGEM/ ASSEMBLY/ ARMADO

Passo/ Step/ Paso 01

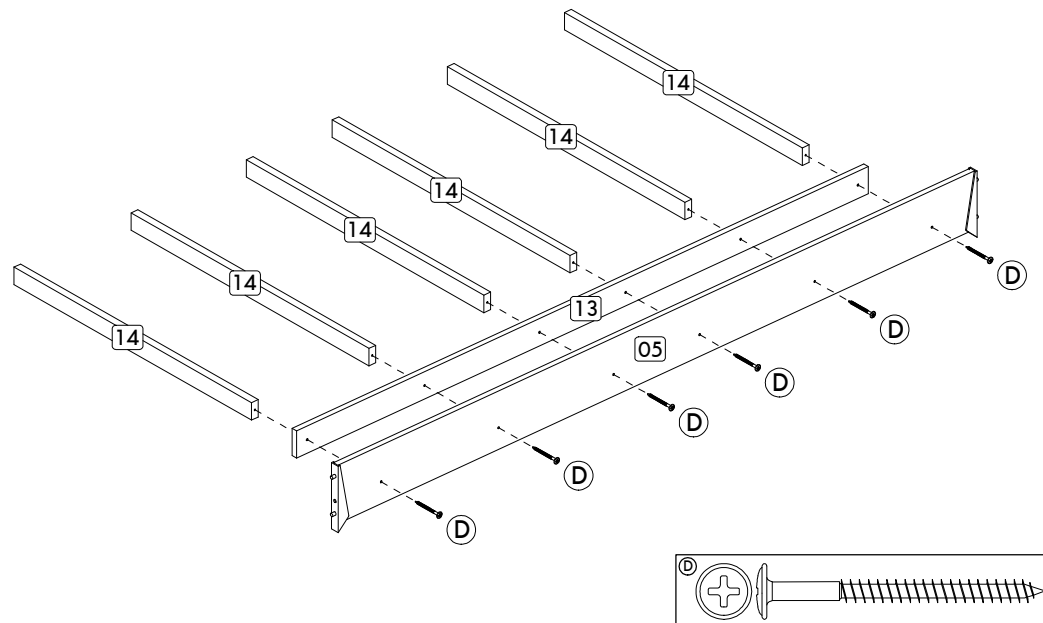

Passo/ Step/ Paso 02

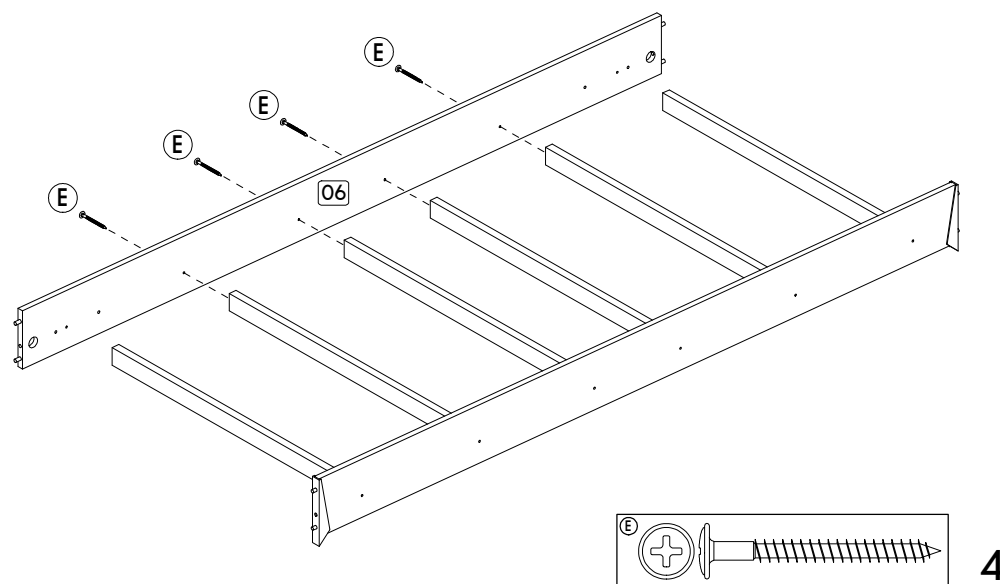

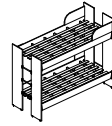

NOTA: Se optou por montar o móvel para a direita, vá para a página 7.
NOTE: If you chose assembling the product to the right, go to page 7.
NOTA: Si elegiste armar el producto a la derecha, vaya a la página 7.

Passo/ Step/ Paso 03

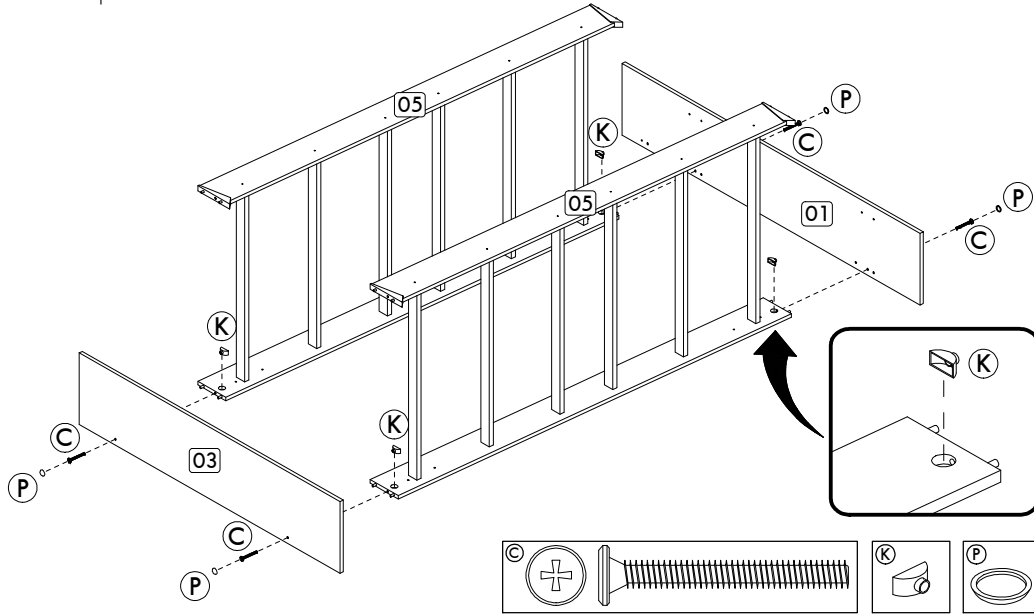

Passo/ Step/ Paso 05

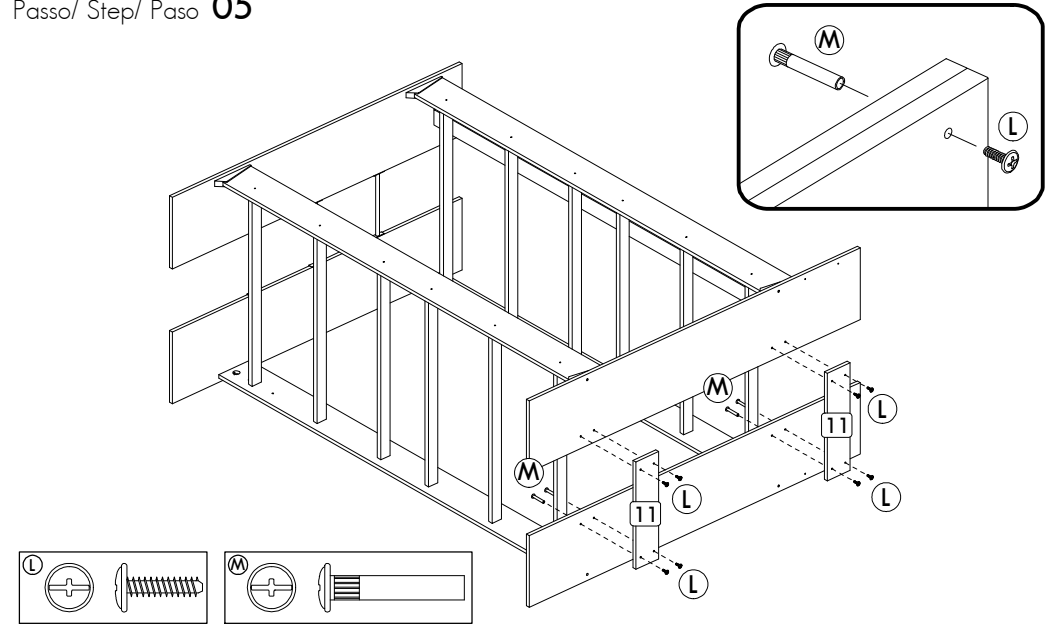

Passo/ Step/ Paso 04

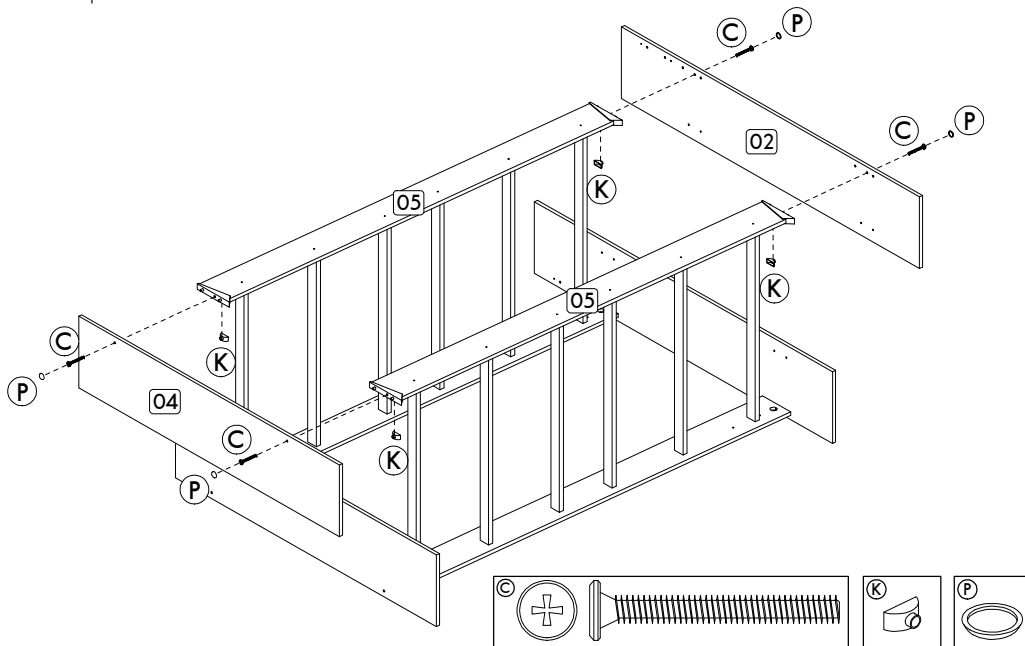

Passo/ Step/ Paso 06

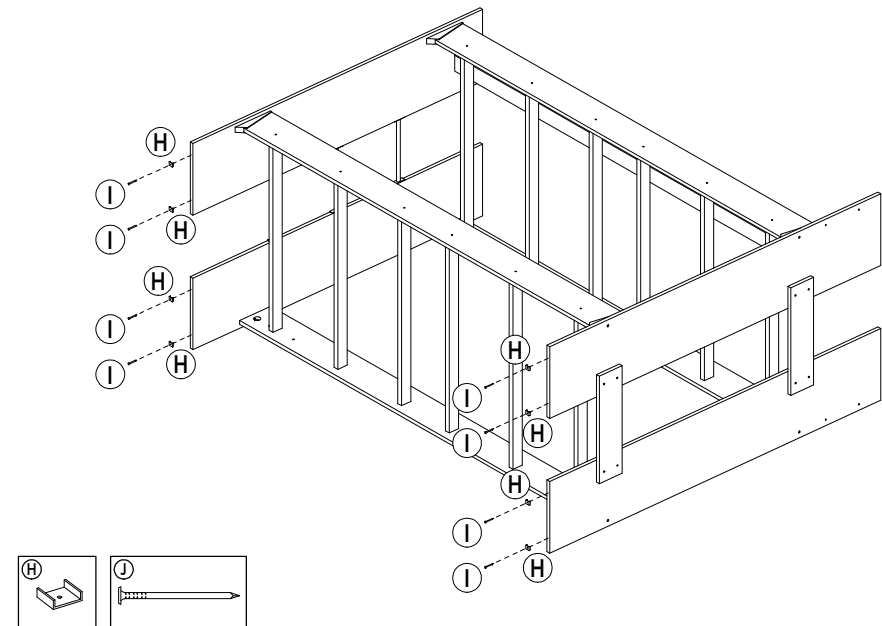

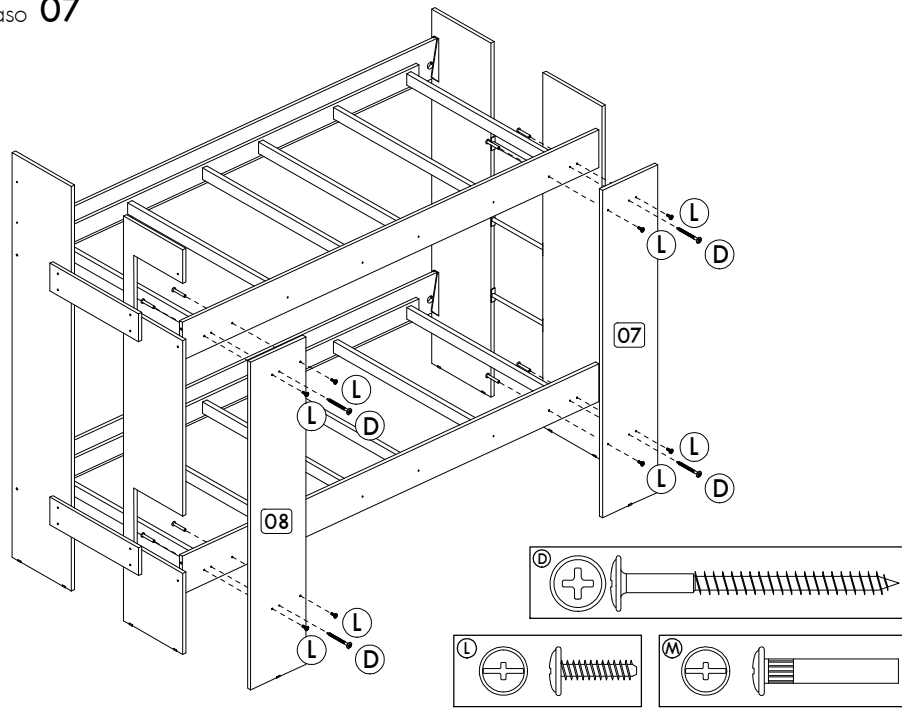

IMPORTANT!
 É imprescindível a instalação dos degraus metálicos. E o acesso ao nível superior deve ser sempre realizado por eles, por segurança.
IMPORTANT!
 It's essential the installation of metal stairs. And the access to higher level should always be performed by them for security.
IMPORTANT!
 Es fundamental la instalación de escaleras de metal. Y el acceso a un nivel superior siempre debe ser cumplido por ellas por un tema de seguridad.

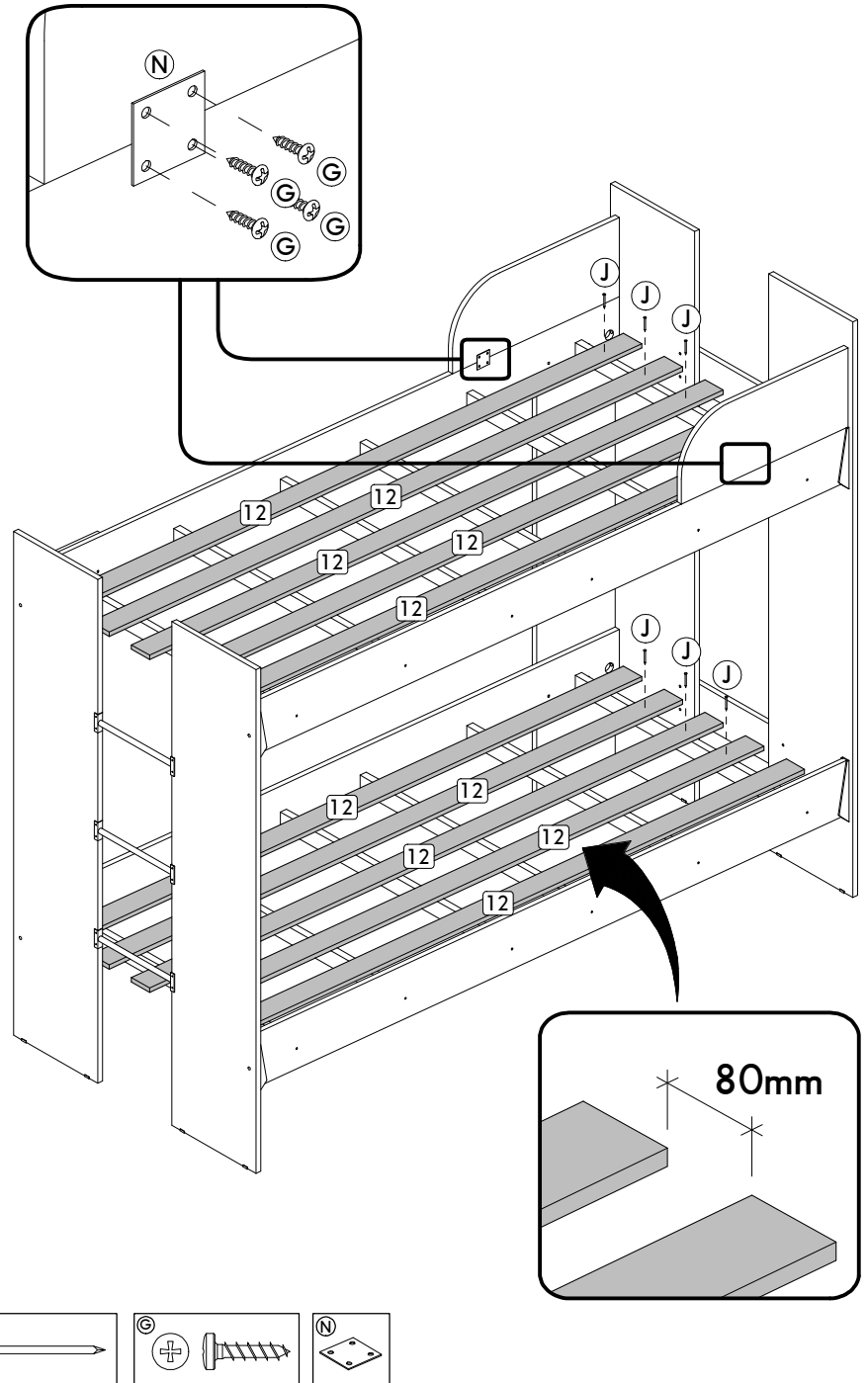
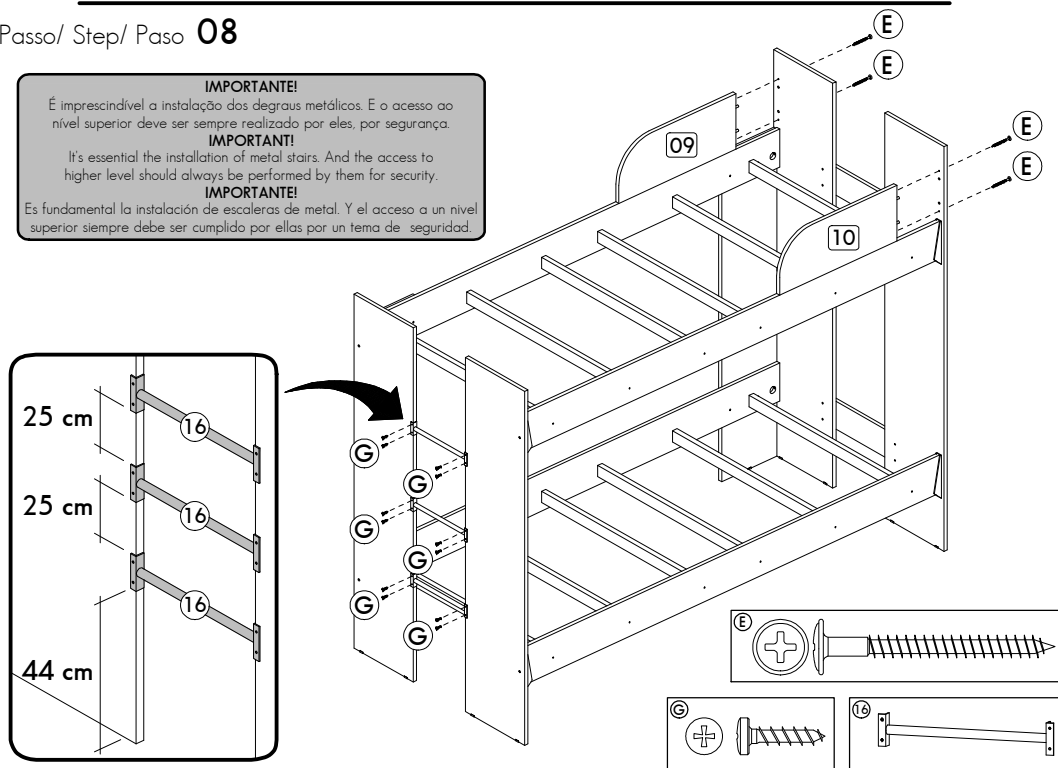

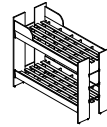

Passo/ Step/ Paso 03

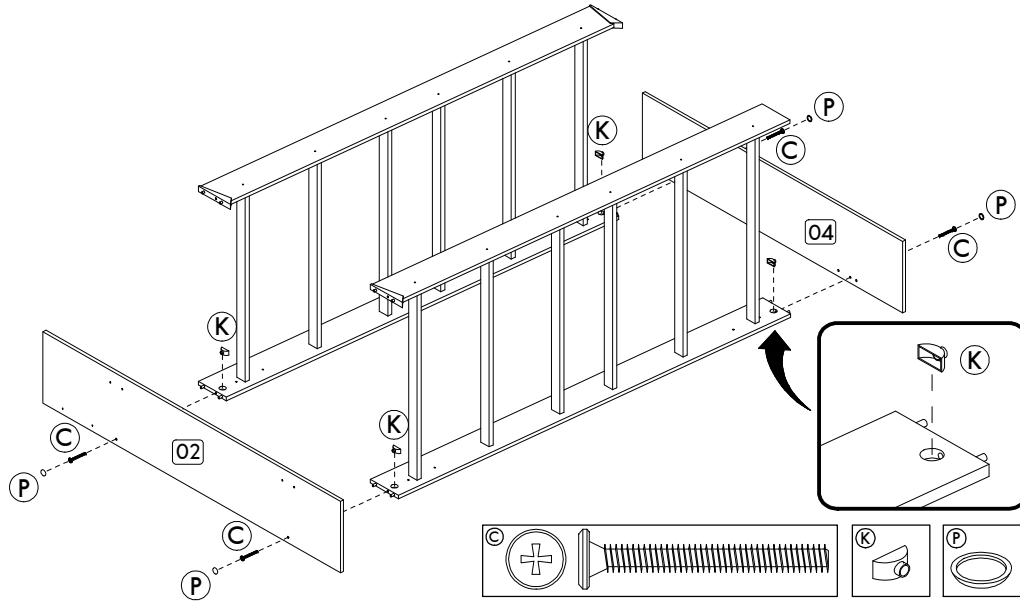

Passo/ Step/ Paso 04

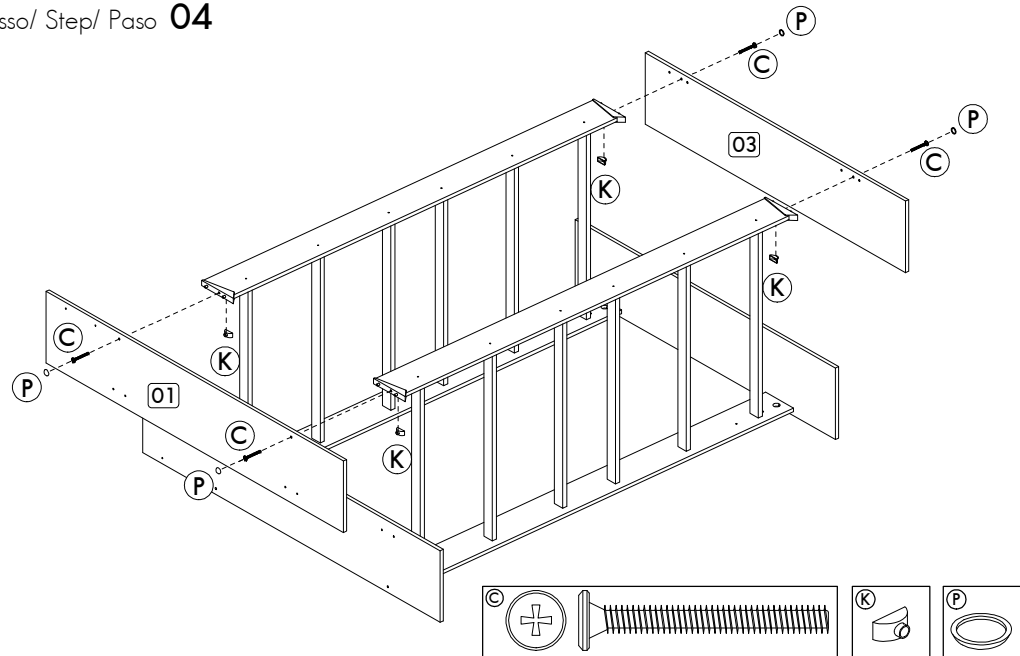

Passo/ Step/ Paso 05

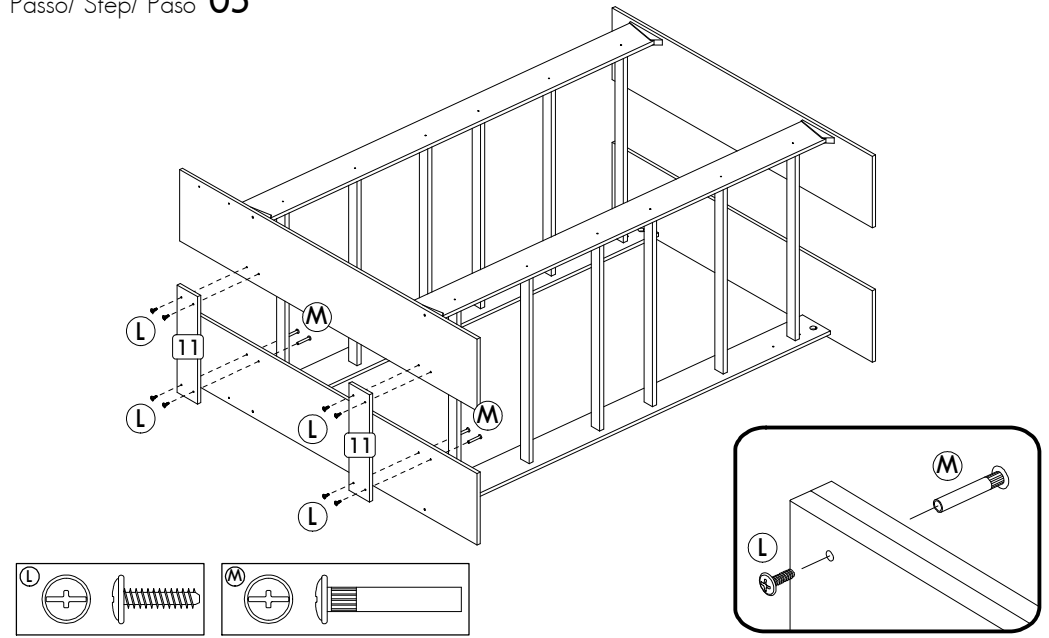

Passo/ Step/ Paso 06

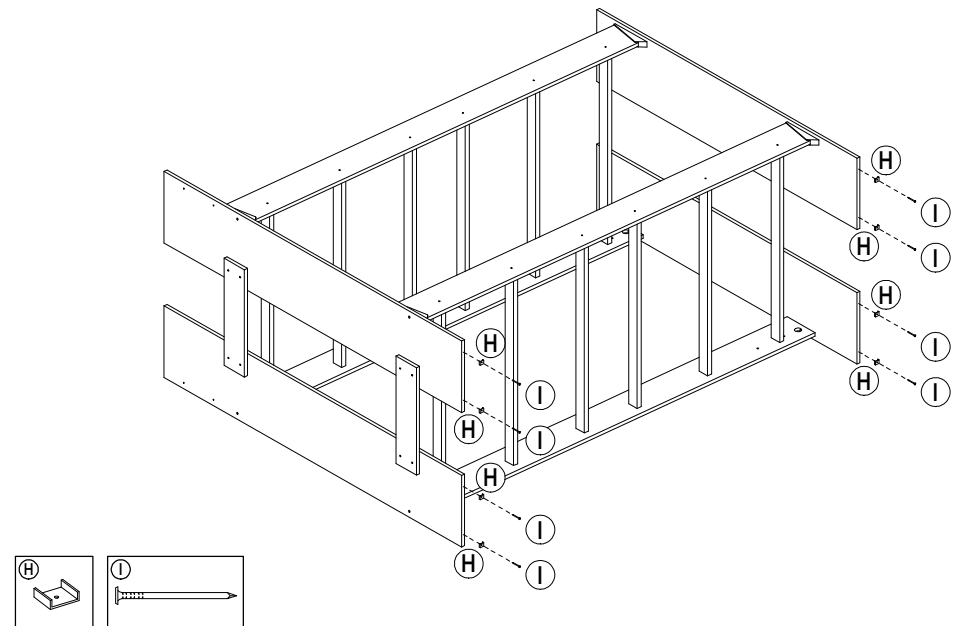

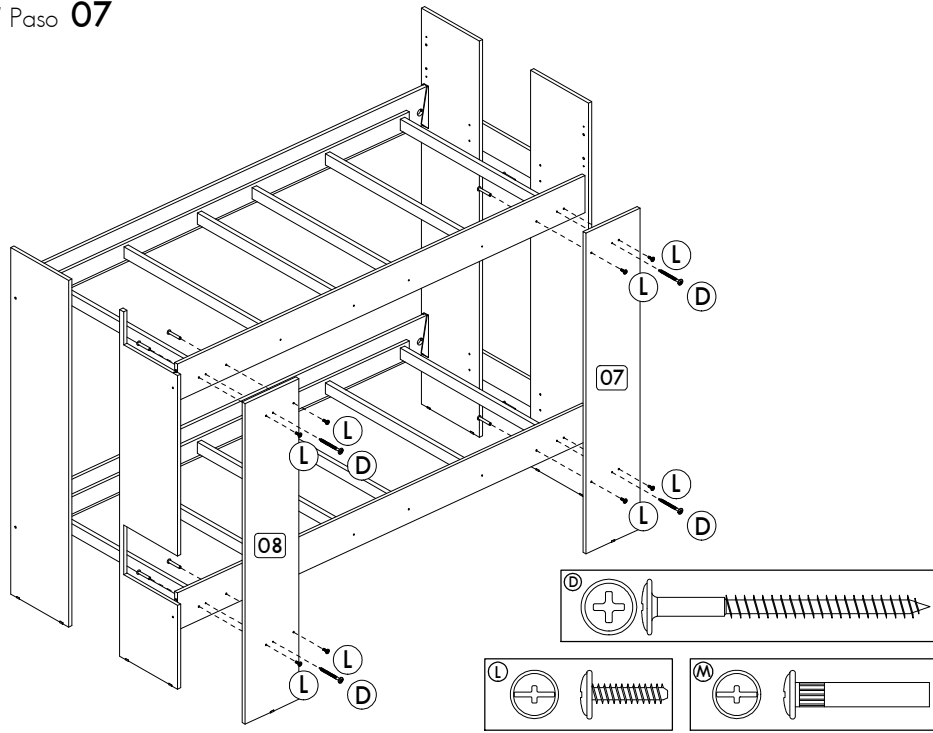

IMPORTANTE!
 É imprescindível a instalação dos degraus metálicos. E o acesso ao nível superior deve ser sempre realizado por eles, por segurança.
IMPORTANT!
 It's essential the installation of metal stairs. And the access to higher level should always be performed by them for security.
IMPORTANTE!
 Es fundamental la instalación de escaleras de metal. Y el acceso a un nivel superior siempre debe ser cumplido por ellas por un tema de seguridad.

