

# RACK QUERÊNCIA

Querencia Rack  
Rack Querencia

Código 2393 | Revisão 01

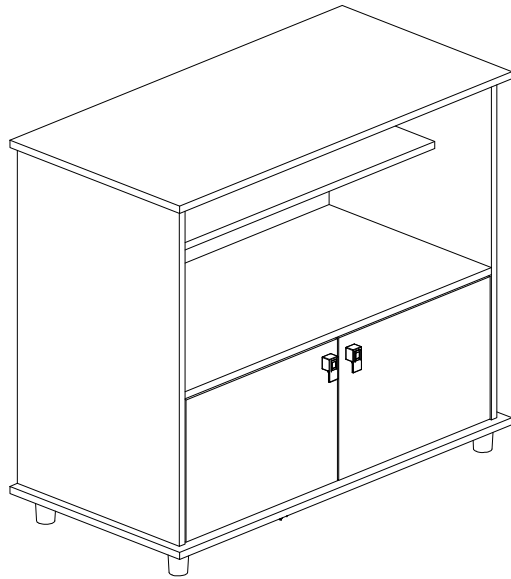

## PESO MÁXIMO SUPORTADO PELAS PEÇAS, SENDO ESTE DISTRIBUÍDO UNIFORMEMENTE.

Maximum weight supported by parts, being this evenly distributed.  
Peso máximo soportado por las partes, siendo esta distribuido uniformemente.

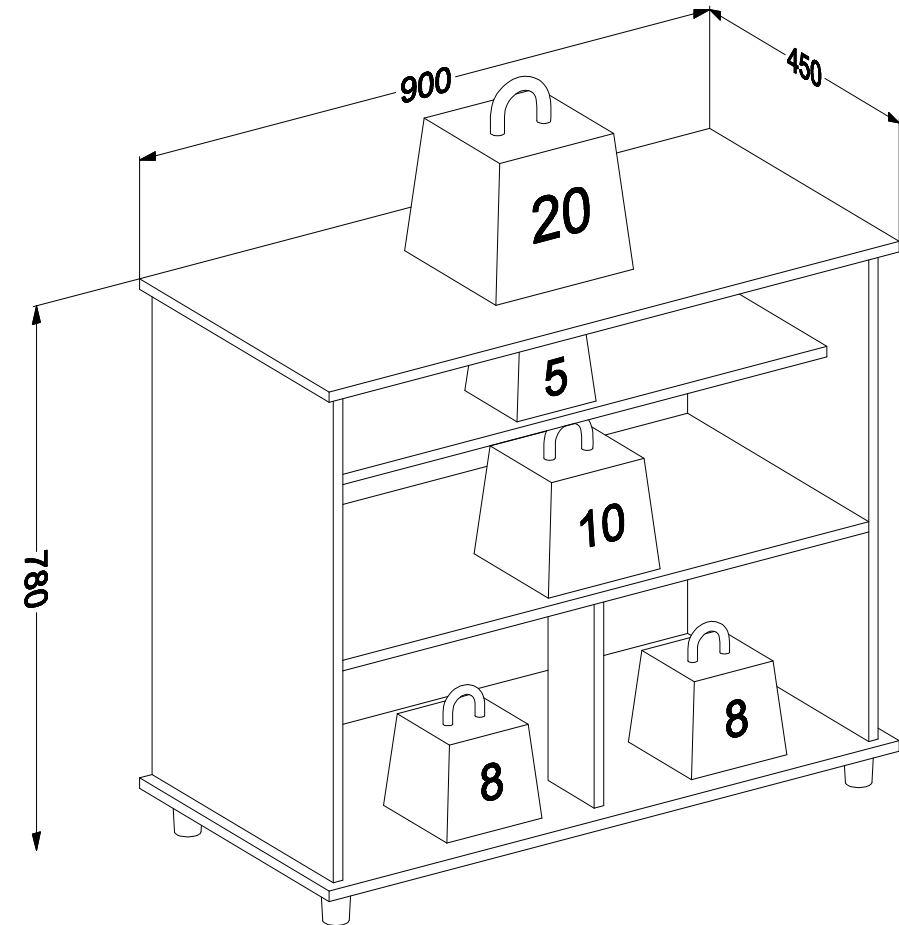

## Você vai precisar de/ You will need / Usted necesitará

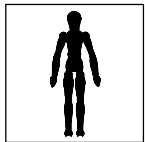

1 Pessoa  
1 Person  
1 Persona

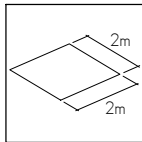

Espaço recomendado para montagem  
Recommended space for assemble  
Espacio recomendado para el armado

Ferramentas não inclusas  
Tools not included / Herramientas no incluidas

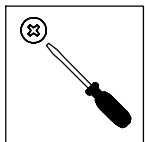

Chave Philips  
Screwdriver  
Destornillador cruz

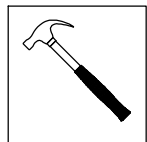

Martelo  
Hammer  
Martillo









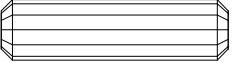
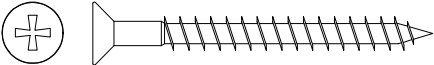
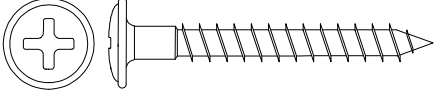

\* PESO EM KG/ Weight in Kg/ Peso en Kg  
DIMENSÕES EM MM/ Dimensions in mm/ Dimensiones en mm

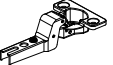
**IDENTIFICAÇÃO DOS ACESSÓRIOS / IDENTIFICATION OF ACCESSORIES/ IDENTIFICACIÓN DE ACCESORIOS**

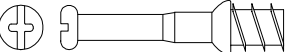
**NOTAS:** A separação dos acessórios antes de iniciar a montagem facilitará a mesma. Os parafusos e cavilhas estão na escala real. Em caso de dúvida na identificação, coloque o acessório sobre a imagem.

**NOTES:** The separation of the accessories before you start the assembly will facilitate the same. The screws and dowels are in real scale. In case of doubts about the identification, place the accessory on the image.

**NOTAS:** La separación de los accesorios antes de comenzar el armado facilitará el mismo. Los tornillos y taquetes son en escala real. En caso de dudas sobre la identificación, coloque el accesorio en la imagen.

<b>A</b>		<b>Cavilha</b> Wooden Dowel Pin	8x30 mm	<b>18</b>
<b>B</b>		<b>Parafuso chato</b> Flat head screw Tornillo de cabeza plana	4,5x45 mm	<b>13</b>
<b>C</b>		<b>Parafuso flangeado</b> Flanged head screw Tornillo de cabeza flangeada	5,0x40 mm	<b>04</b>
<b>D</b>		<b>Parafuso flangeado</b> Flanged head screw Tornillo de cabeza flangeada	3,5x25 mm	<b>02</b>
<b>E</b>		<b>Parafuso panela</b> Pan head screw Tornillo de pan	3,5x14 mm	<b>16</b>
<b>F</b>		<b>Dobradiça super alta</b> Metal hinge super high Bisagra alta	26mm	<b>04</b>
<b>G</b>		<b>Calço dobradiça</b> Hinge shim Bisagra de calce	-	<b>04</b>
<b>H</b>		<b>Prego</b> Nail Clavo	10 x10	<b>22</b>
<b>I</b>		<b>Haste minifix simples</b> Simple minifix screw Tornillo minifix simple	-	<b>05</b>
<b>J</b>		<b>Tambor minifix</b> Drum lock Tambor minifix	12 mm	<b>05</b>
<b>K</b>		<b>Tapa furo adesivo</b> Bore patch adhesive Tapones adhesivo	22mm	<b>05</b>
<b>L</b>		<b>Puxador</b> Handle Tirador	-	<b>02</b>
<b>M</b>		<b>Tapa furo adesivo</b> Bore patch adhesive Tapones adhesivo	15m	<b>08</b>
<b>N</b>		<b>Sapata</b> Plastic foot Pie plástico	-	<b>04</b>

**IDENTIFICAÇÃO DAS PEÇAS/ PARTS IDENTIFICATION/ IDENTIFICACIÓN DE LAS PIEZAS**

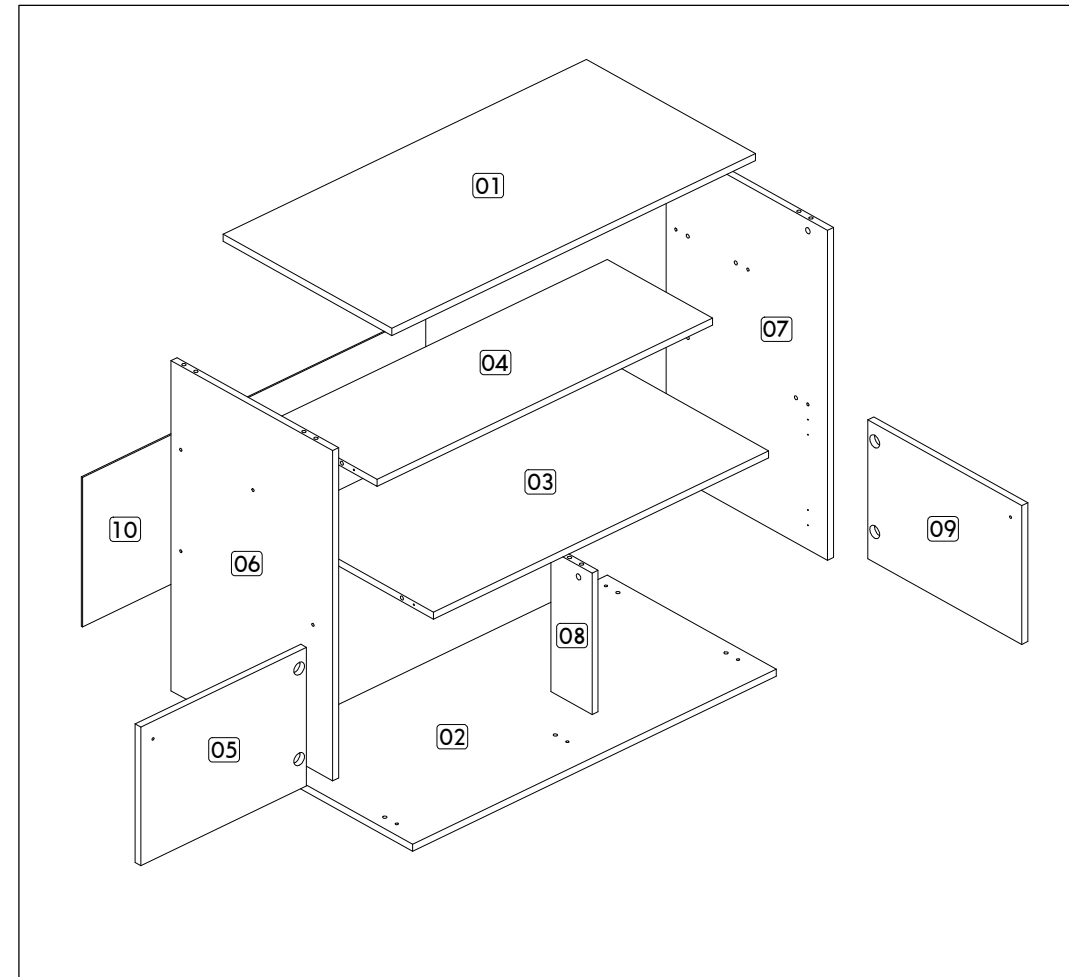

<b>Nº</b>	<b>DESCRIÇÃO - DESCRIPTION - DESCRIPCIÓN</b>	<b>MEDIDAS-MEASURES - MEDIDAS (mm)</b>	<b>QTD.</b>
01	<b>Base superior</b> - Top base - Base superior	900 x 450 x 15	01
02	<b>Base inferior</b> - Bottom base - Base inferior	900 x 450 x 15	01
03	<b>Base</b> - Base - Base	830 x 430 x 15	01
04	<b>Prateleira</b> - Shelf - Repisa	830 x 280 x 15	01
05	<b>Porta esquerda</b> - Left door - Puerta izquierda	410 x 294 x 15	01
06	<b>Lateral esquerda</b> - Left side - Lateral izquierda	700 x 430 x 15	01
07	<b>Lateral direita</b> - Right side - Lateral derecha	700 x 430 x 15	01
08	<b>Travessa</b> - Tray - Traviesa	300 x 110 x 15	01
09	<b>Porta direita</b> - Right door - Puerta derecha	410 x 294 x 15	01
10	<b>Costa</b> - Back - Fondo	850 x 317 x 03	01

PRÉ-MONTAGEM/ PRE-ASSEMBLE/ PRE ARMADO

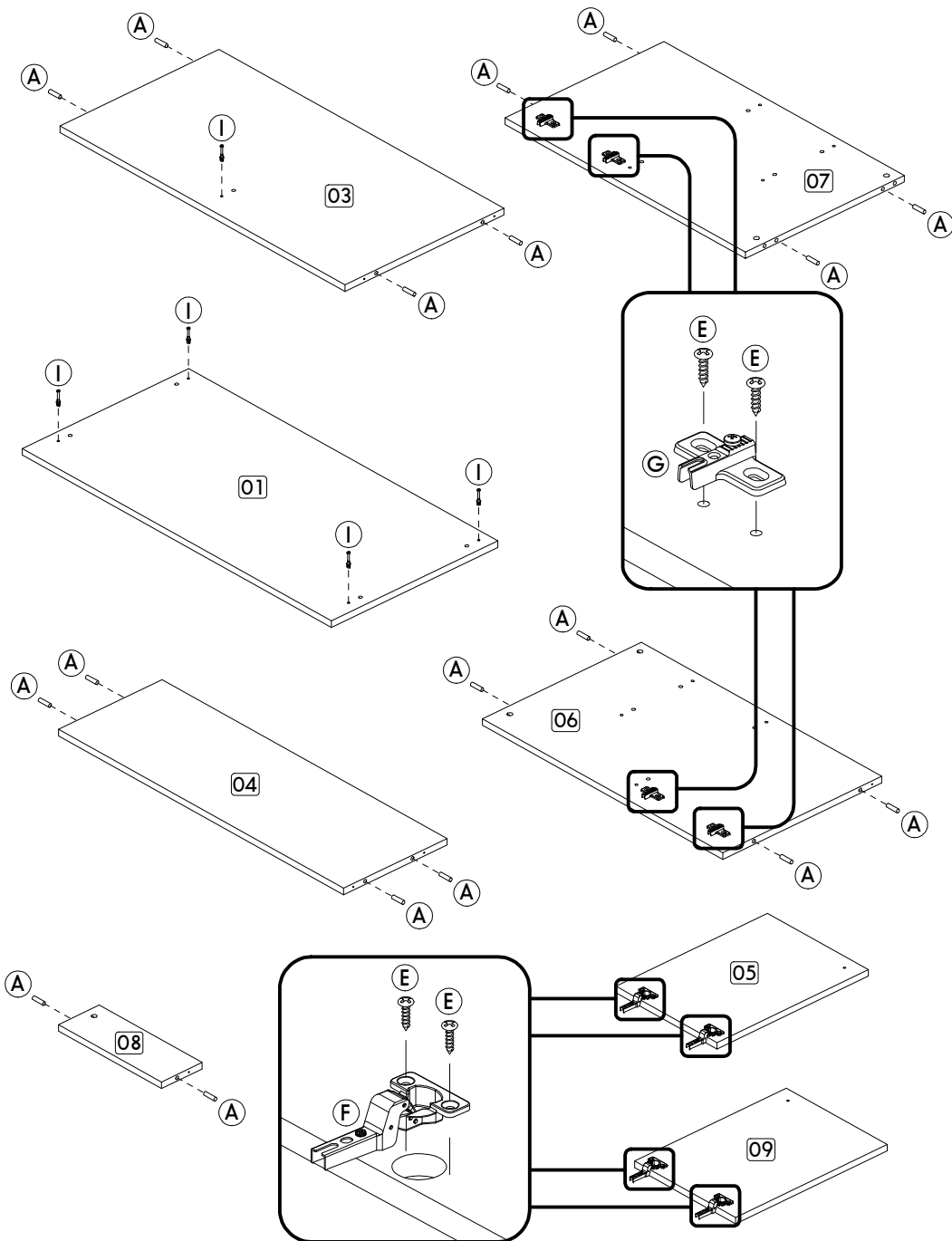

MONTAGEM/ ASSEMBLY/ ARMADO

Passo/ Step/ Paso 01

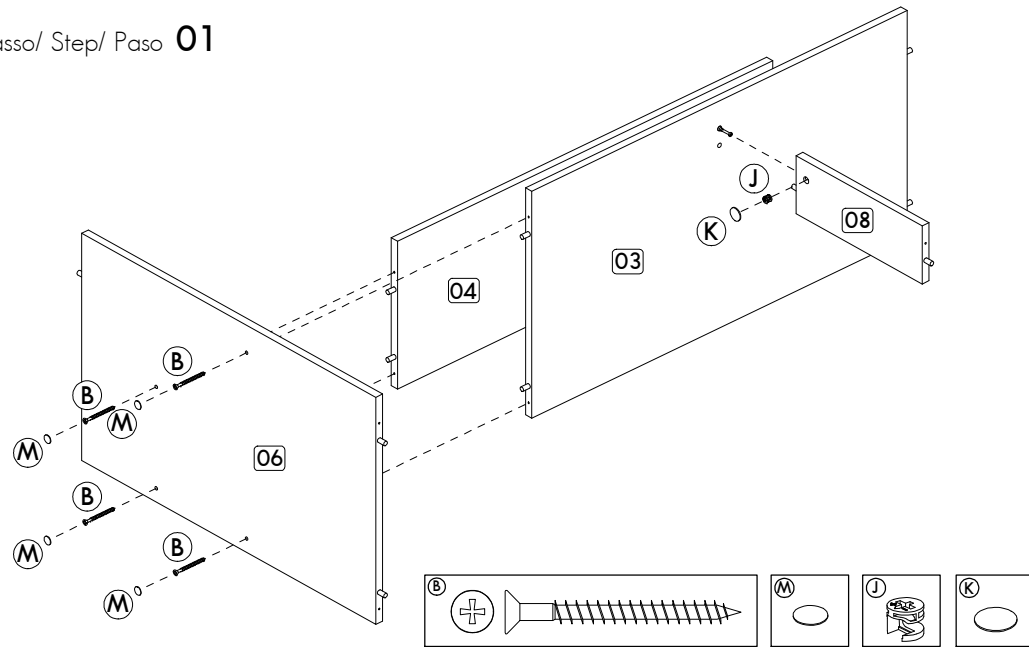

Passo/ Step/ Paso 02

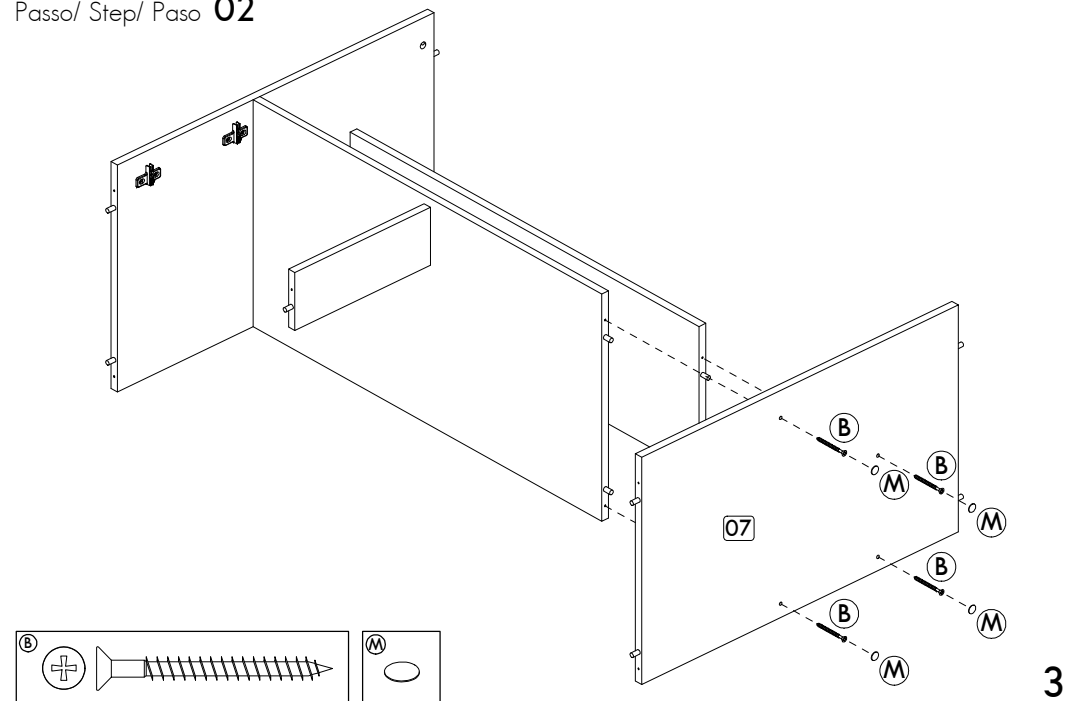

Passo/ Step/ Paso 03

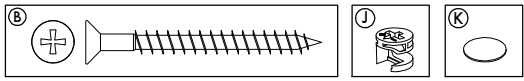
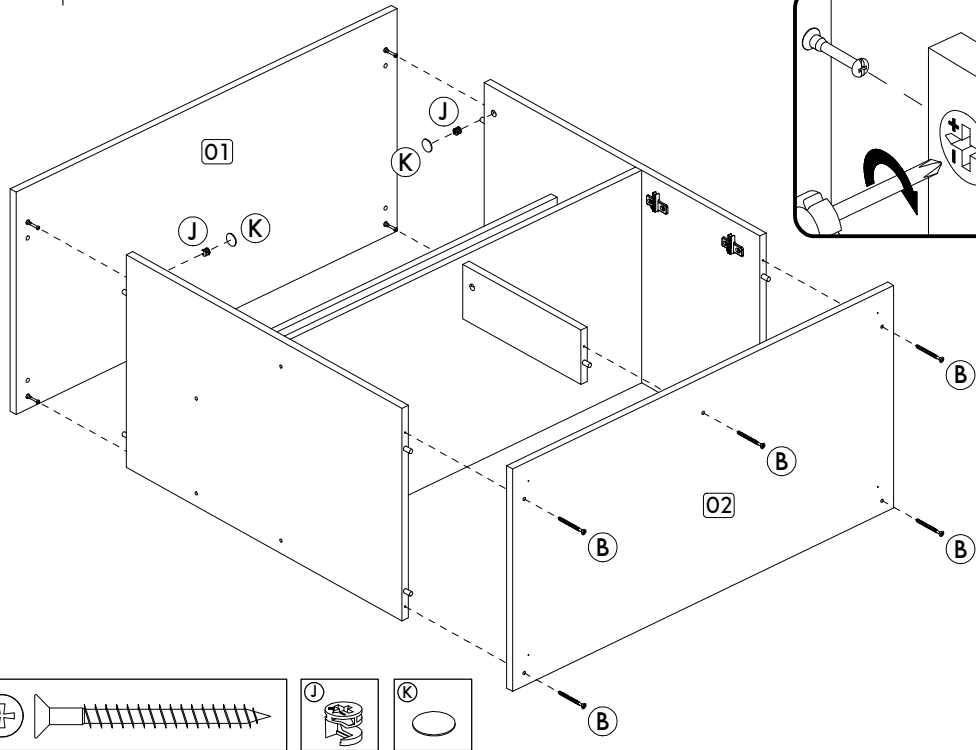

Passo/ Step/ Paso 04

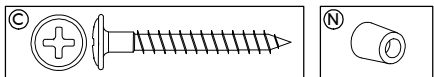
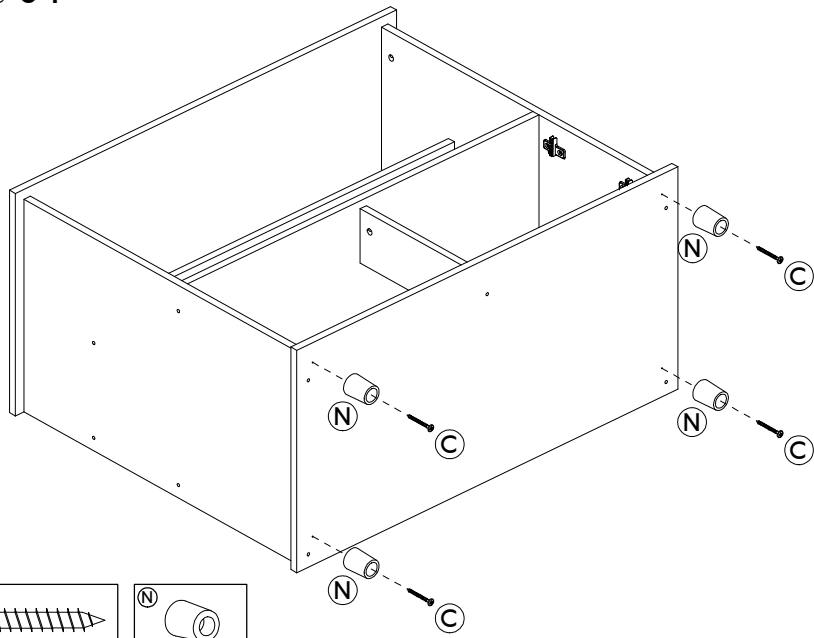

Passo/ Step/ Paso 05

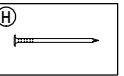
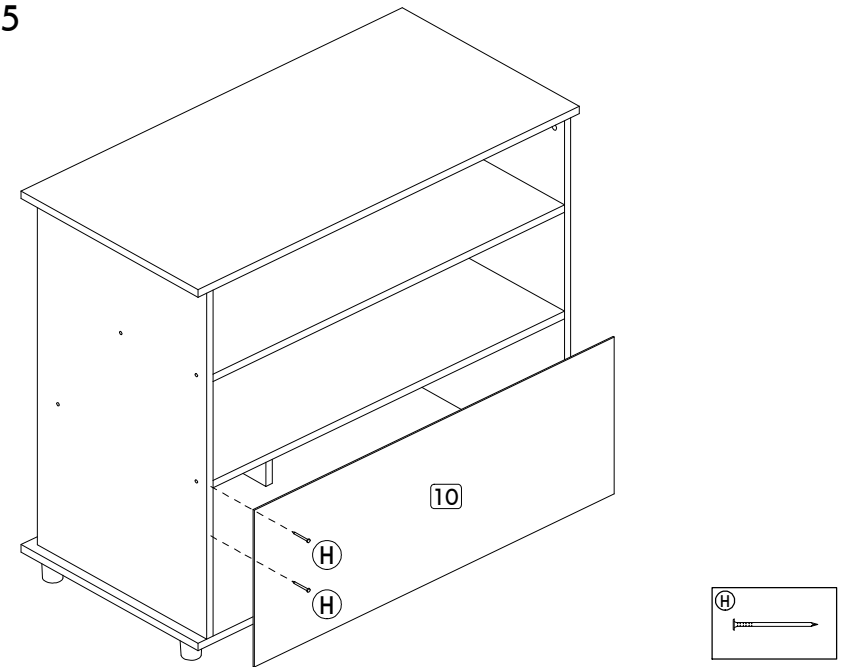

Passo/ Step/ Paso 06

