

GAVETEIRO MAIA - 3 GAVETAS

Drawer cabinet **Maia** - 3 drawers
Cajonera **Maia** - 3 cajones

Código **2487** | Revisão 01

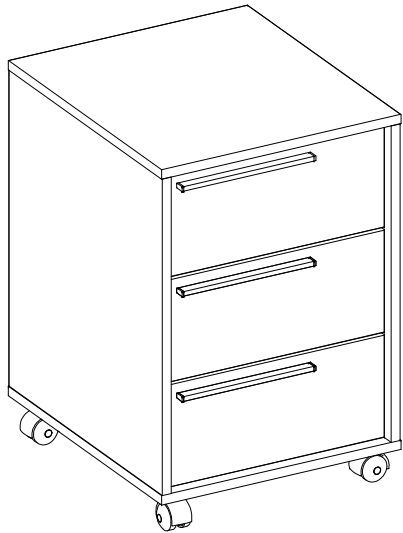

PESO MÁXIMO SUPORTADO PELAS PEÇAS, SENDO ESTE DISTRIBUÍDO UNIFORMEMENTE.

Maximum weight supported by parts, being this evenly distributed.
Peso máximo soportado por las partes, siendo esta distribuido uniformemente.

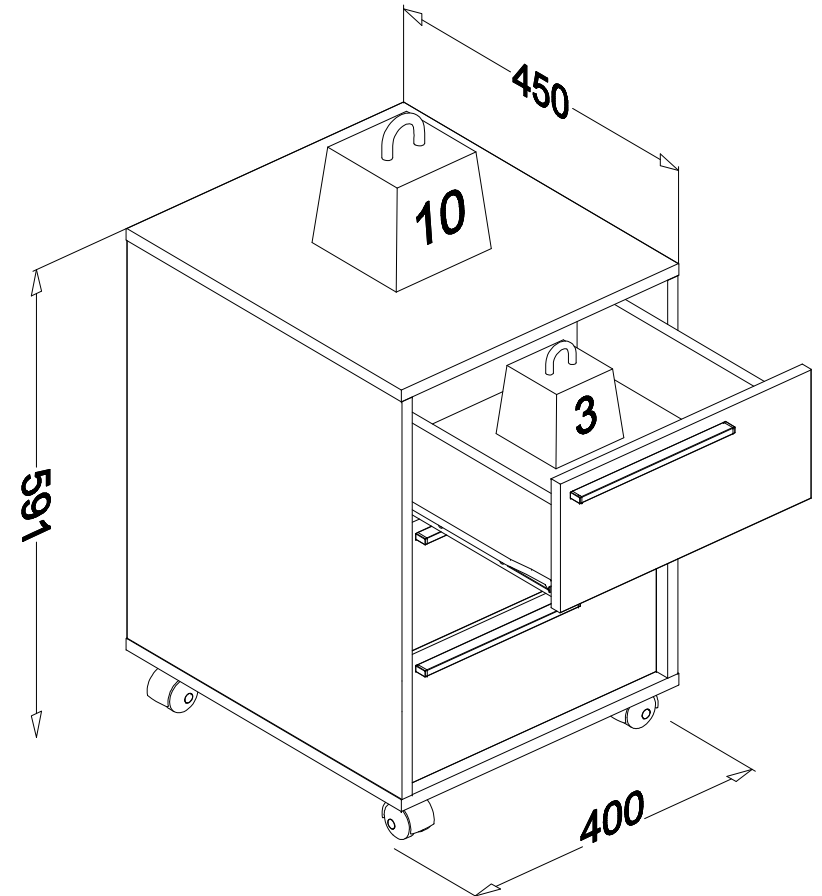

Você vai precisar de/ You will need / Usted necesitará

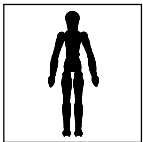

1 Pessoa
1 Person
1 Persona

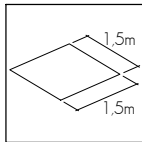

Espaço recomendado para montagem
Recommended space for assemble
Espacio recomendado para el armado

Ferramentas não inclusas
Tools not included / Herramientas no incluidas

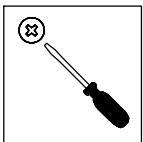







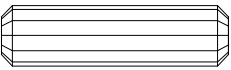
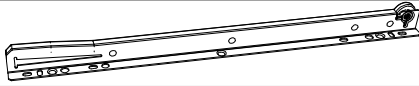
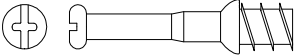
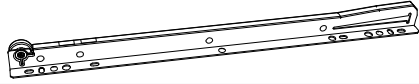

Chave Philips
Screwdriver
Destornillador cruz

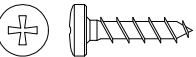
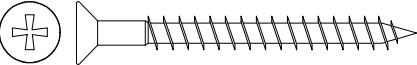
* PESO EM KG/ Weight in Kg/ Peso en Kg
DIMENSÕES EM MM/ Dimensions in mm/ Dimensiones en mm

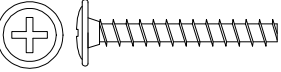
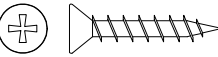
IDENTIFICAÇÃO DOS ACESSÓRIOS/ IDENTIFICATION OF ACCESSORIES/ IDENTIFICACIÓN DE ACCESORIOS

NOTAS: A separação dos acessórios antes de iniciar a montagem facilitará a mesma. Os parafusos e cavilhas estão na escala real. Em caso de dúvida na identificação, coloque o acessório sobre a imagem.
NOTES: The separation of the accessories before you start the assembly will facilitate the same. The screws and dowels are in real scale. In case of doubts about the identification, place the accessory on the image.
NOTAS: La separación de los accesorios antes de comenzar el armado facilitará el mismo. Los tornillos y taquetes son en escala real. En caso de dudas sobre la identificación, coloque el accesorio en la imagen.

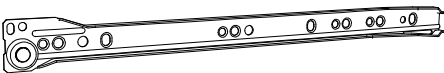
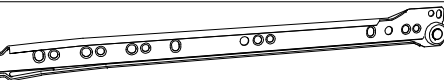
A		Cavilha Wooden Dowel Pin	8x30 mm	32	13C		Corrediça gaveta esquerda Drawer slide left Corredera izquierda cajón	350 mm	03
B		Haste minifix simples Simple minifix screw Tornillo minifix simple	-	10	13D		Corrediça gaveta direita Drawer slide right Corredera derecha cajón	350 mm	03
C		Tambor minifix Drum lock Tambor minifix	12 mm	10					
D		Parafuso chato Flat head screw Tornillo de cabeza plana	3,0x14 mm	24					
E		Parafuso panela Pan head screw Tornillo de pan	3,5x14 mm	16					
F		Parafuso chato Flat head screw Tornillo de cabeza plana	4,5x45 mm	10					
G		Tapa furo adesivo Bore patch adhesive Tapones adhesivo	-	06					
H		Cola Glue Pegamento	13g	01					
I		Parafuso flangeado Flanged head screw Tornillo de cabeza flangeada	3,5x25 mm	06					
J		Parafuso chato Flat head screw Tornillo de cabeza plana	3,5x20 mm	04					
K		Suporte triangular Triangular support Soporte triangular	-	04					
11		Puxador Handle Tirador	-	03					
12		Rodizio Caster Ruedas	-	04					
13A		Corrediça lateral esquerda Metallic slide the left field Corredera lateral izquierda	350 mm	03					
13B		Corrediça lateral direita Metallic slide the right field Corredera lateral derecha	350 mm	03					

IDENTIFICAÇÃO DAS PEÇAS/ PARTS IDENTIFICATION/ IDENTIFICACIÓN DE LAS PIEZAS

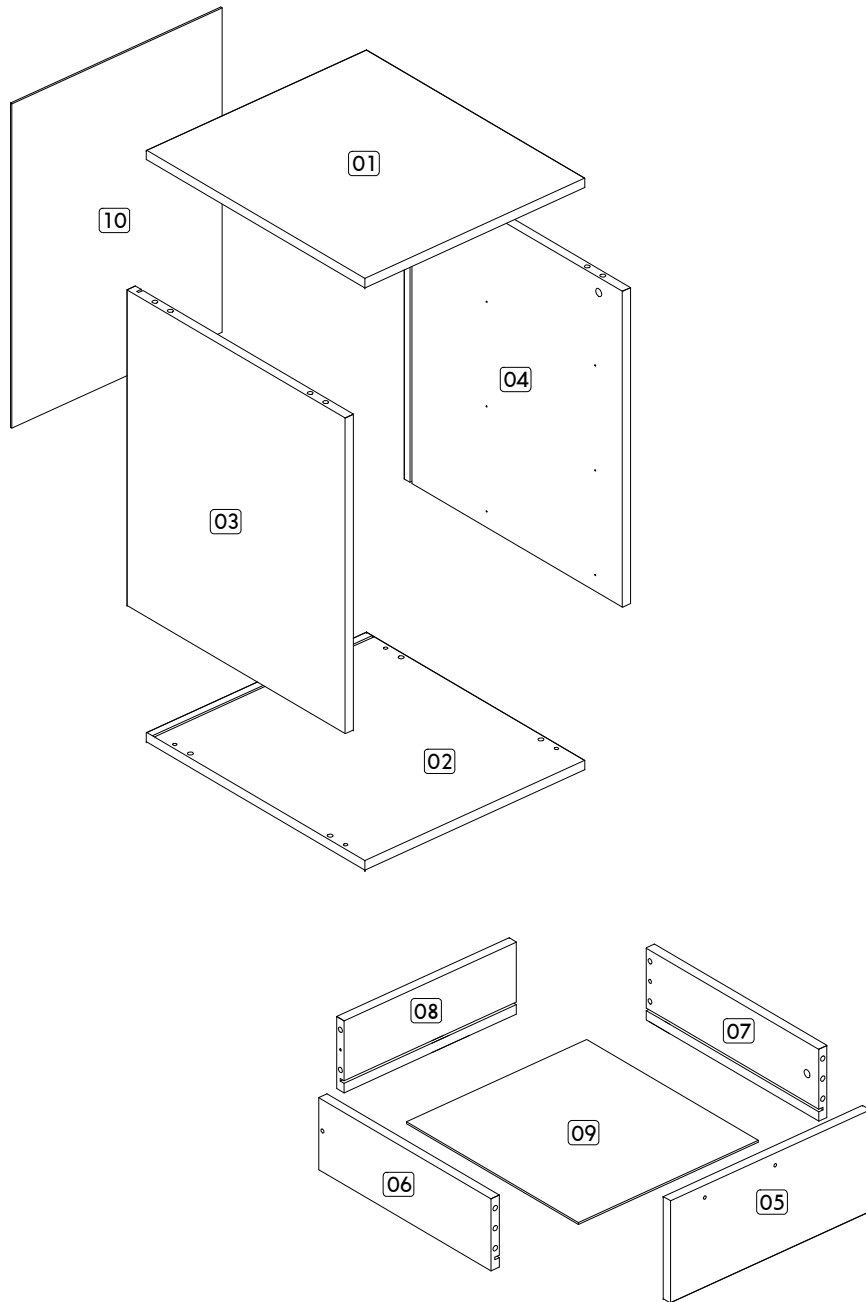

Nº	DESCRIÇÃO - DESCRIPTION - DESCRIPCIÓN	MEDIDAS-MEASURES - MEDIDAS (mm)	QTD.
01	Tampo - Top - Tapa	450 x 400 x 15	01
02	Base inferior - Bottom base - Base inferior	450 x 400 x 15	01
03	Lateral esquerda - Left side - Lateral izquierda	503 x 450 x 15	01
04	Lateral direita - Right side - Lateral derecha	503 x 450 x 15	01
05	Frente de gaveta - Drawer front - Frente del cajón	362 x 163 x 15	03
06	Lateral esquerda de gaveta - Left side of drawer - Lateral izquierda del cajón	355 x 115 x 15	03
07	Lateral direita de gaveta - Right side of drawer - Lateral derecha del cajón	355 x 115 x 15	03
08	Traseiro de gaveta - Rear of drawer - Trasero del cajón	313 x 115 x 15	03
09	Fundo de gaveta - Bottom of drawer - Fondo del cajón	354 x 327 x 03	03
10	Costa - Back - Fondo	518 x 383 x 03	01

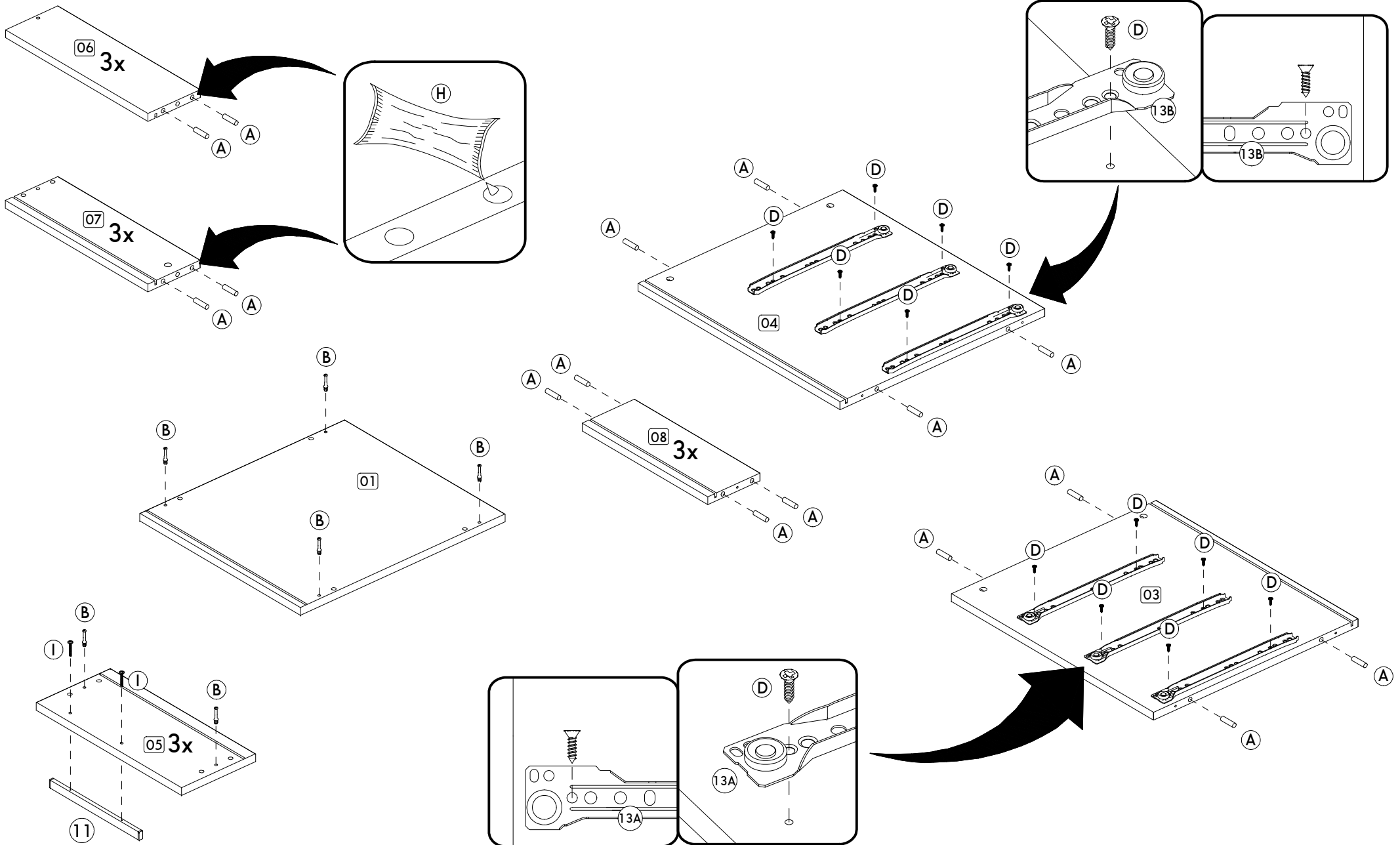

Passo/ Step/ Paso 01

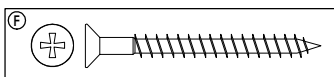
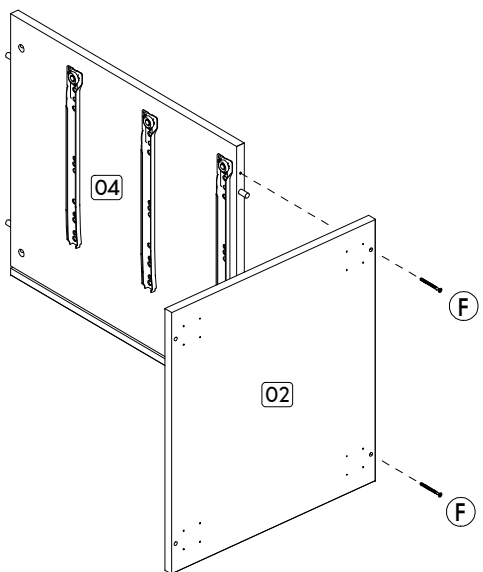

Passo/ Step/ Paso 02

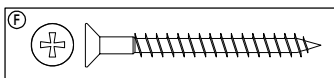
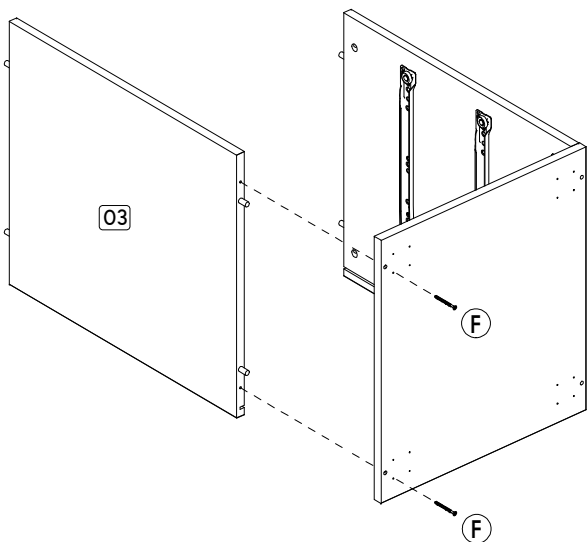

Passo/ Step/ Paso 03

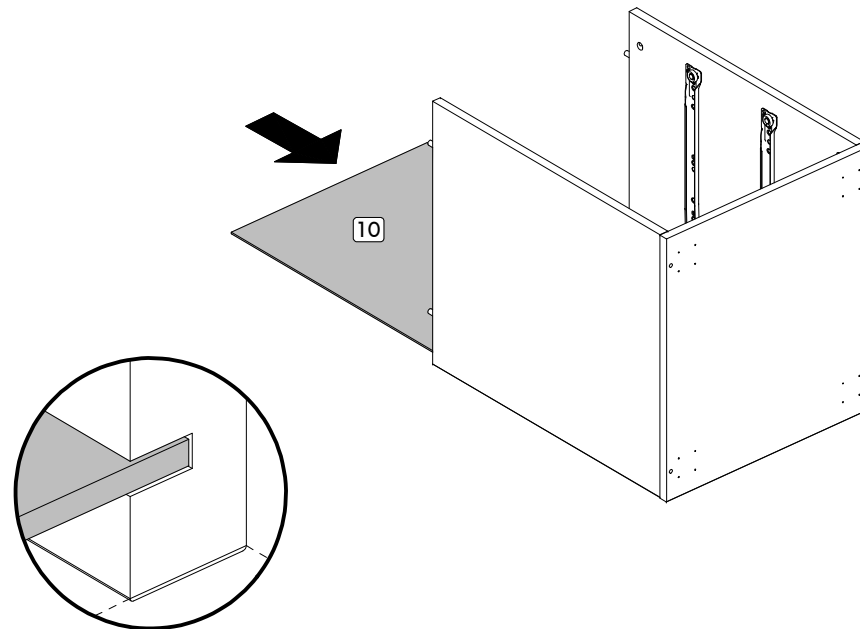

Passo/ Step/ Paso 04

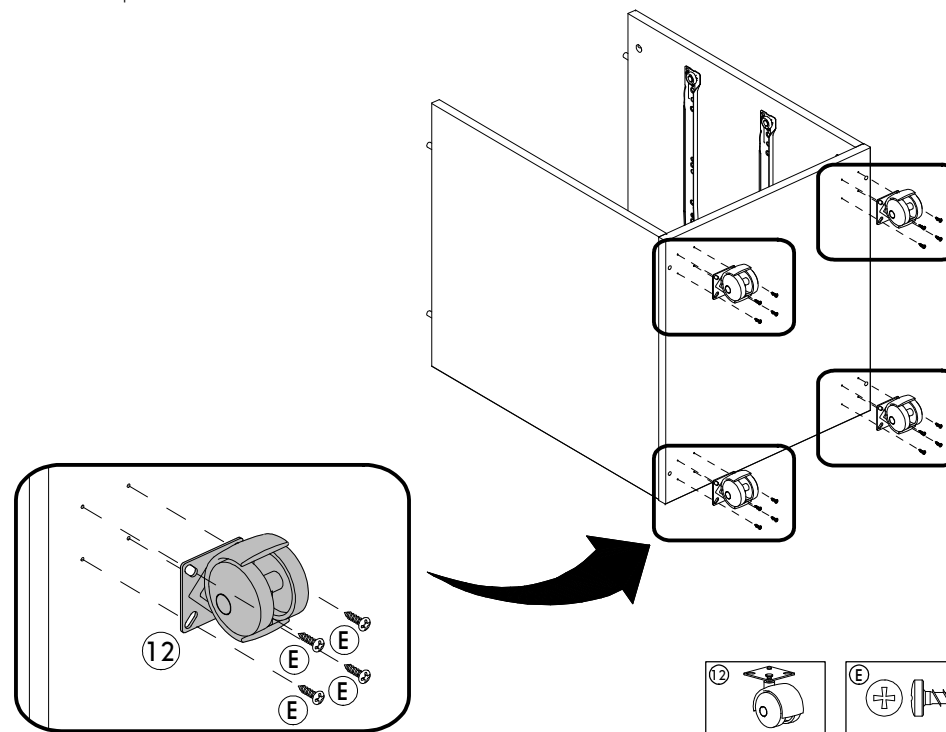

Passo/ Step/ Paso 05

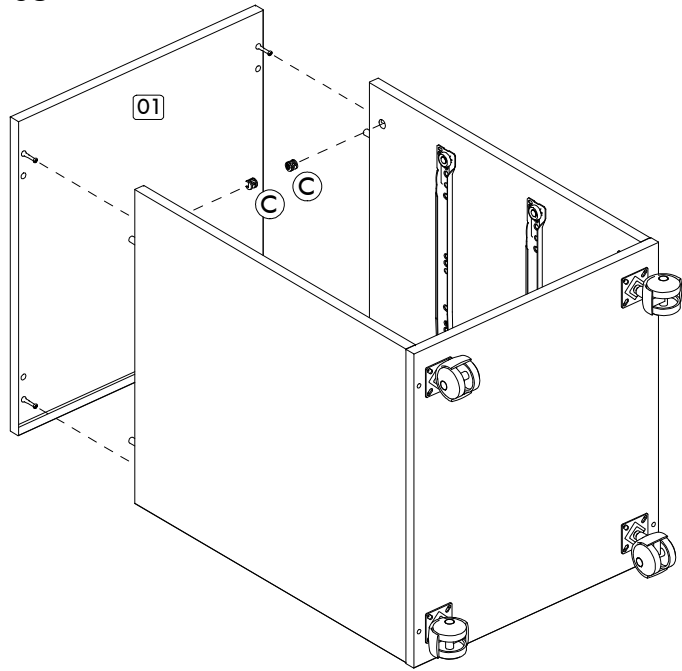

Passo/ Step/ Paso 07

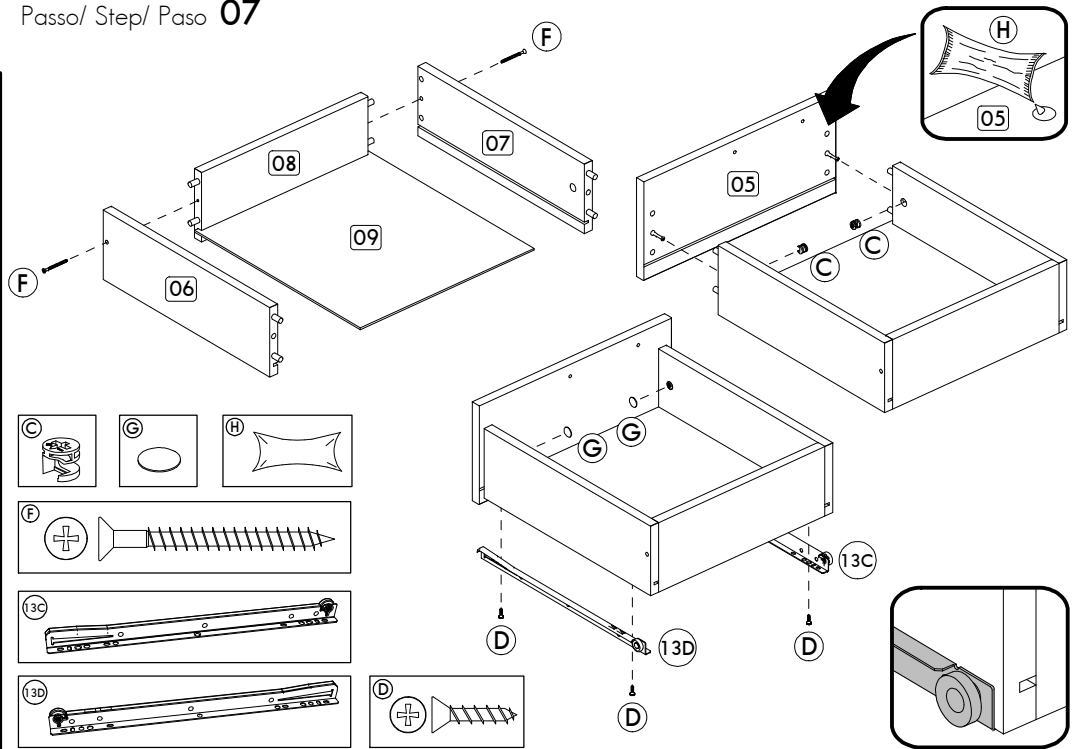

Passo/ Step/ Paso 06

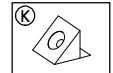
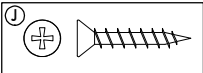
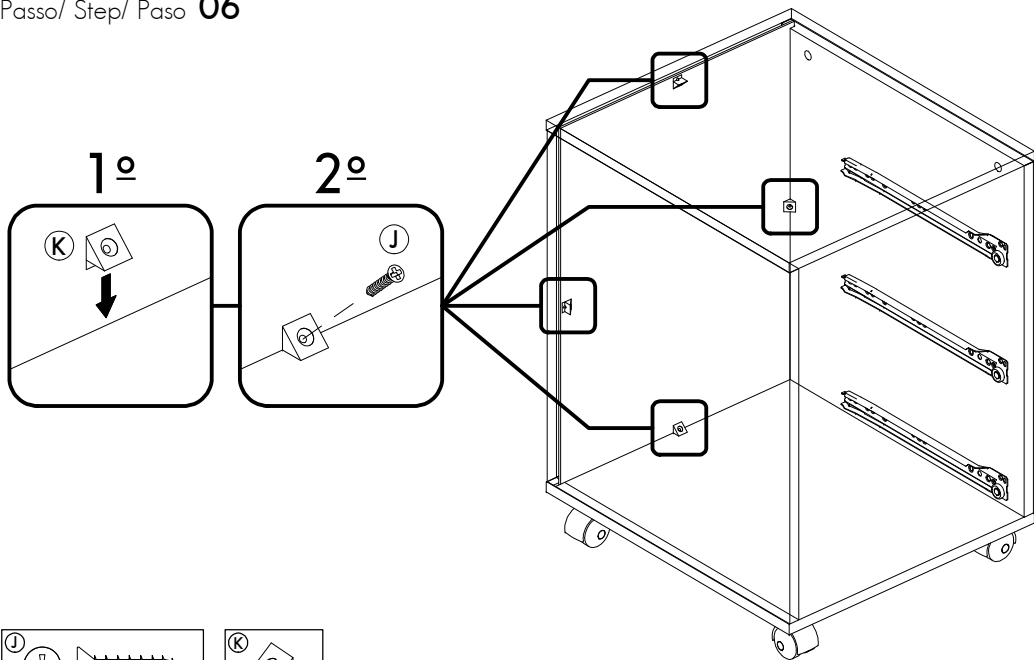

Passo/ Step/ Paso 08

