

# ARMÁRIO ORGANIZADOR CANELA

Organizer Cabinet **Canela**  
Armario Organizador **Canela**

Código **3322** | Revisão 03

**NOTA:** Este produto pode ser montado com a porta para a sua direita ou esquerda.

**NOTE:** This product can be assembled with door to right or left.

**NOTA:** Este producto se puede armar con la puerta a la derecha o izquierda.

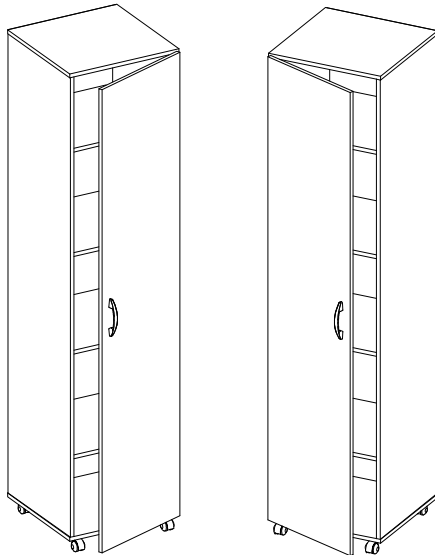

**PESO MÁXIMO SUPORTADO PELAS PEÇAS, SENDO ESTE DISTRIBUÍDO UNIFORMEMENTE.**

Maximum weight supported by parts, being this evenly distributed.

Peso máximo soportado por las partes, siendo esta distribuido uniformemente.

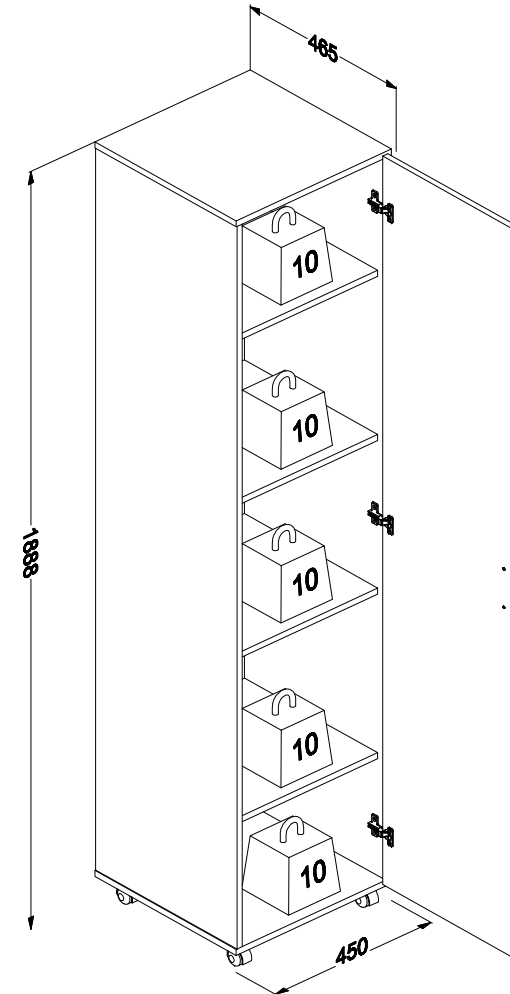

**Você vai precisar de/ You will need / Usted necesitará**

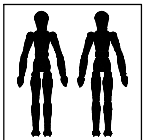

2 Pessoas  
2 People  
2 Personas

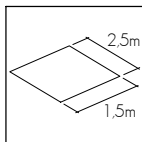

**Espaço recomendado para montagem**  
Recommended space for assemble  
Espacio recomendado para el armado

**Ferramentas não inclusas**  
Tools not included / Herramientas no incluidas

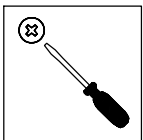

**Chave Philips**  
Screwdriver  
Destornillador cruz

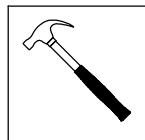

**Martelo**  
Hammer  
Martillo







\* **PESO EM KG/ Weight in Kg/ Peso en Kg**  
**DIMENSÕES EM MM/ Dimensions in mm/ Dimensiones en mm**

**IDENTIFICAÇÃO DOS ACESSÓRIOS / IDENTIFICATION OF ACCESSORIES/ IDENTIFICACIÓN DE ACCESORIOS**

**NOTAS:** A separação dos acessórios antes de iniciar a montagem facilitará a mesma. Os parafusos e cavilhas estão na escala real. Em caso de dúvida na identificação, coloque o acessório sobre a imagem.

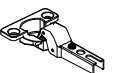
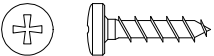
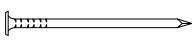
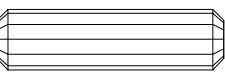
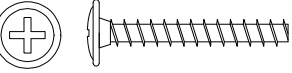
**NOTES:** The separation of the accessories before you start the assembly will facilitate the same. The screws and dowels are in real scale. In case of doubts about the identification, place the accessory on the image.

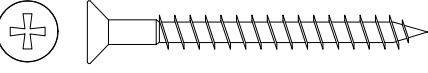
**NOTAS:** La separación de los accesorios antes de comenzar el armado facilitará el mismo. Los tornillos y taquetes son en escala real. En caso de dudas sobre la identificación, coloque el accesorio en la imagen.

<b>A</b>		<b>Haste minifix simples</b> Simple minifix screw Tornillo minifix simple	-	<b>08</b>
<b>B</b>		<b>Tambor minifix</b> Drum lock Tambor minifix	12 mm	<b>08</b>
<b>C</b>		<b>Calço dobradiça</b> Hinge shim Bisagra de calce	5mm	<b>03</b>
<b>D</b>		<b>Dobradiça curva</b> Metal hinge curve Esquina de bisagra metálica	26mm	<b>03</b>
<b>E</b>		<b>Parafuso panela</b> Pan head screw Tornillo de pan	3,5x14 mm	<b>28</b>
<b>F</b>		<b>Prego</b> Nail Clavo	10 x10	<b>55</b>
<b>H</b>		<b>Cavilha</b> Wooden Dowel Pin	8x30 mm	<b>24</b>
<b>I</b>		<b>Parafuso flangeado</b> Flanged head screw Tornillo de cabeza flangeada	3,5x25 mm	<b>02</b>
<b>J</b>		<b>Puxador</b> Handle Tirador	-	<b>01</b>
<b>K</b>		<b>Parafuso chato</b> Flat head screw Tornillo de cabeza plana	4,5x45 mm	<b>08</b>
<b>08</b>		<b>Rodízio</b> Caster Ruedas	-	<b>04</b>

**IDENTIFICAÇÃO DAS PEÇAS/ PARTS IDENTIFICATION/ IDENTIFICACIÓN DE LAS PIEZAS**

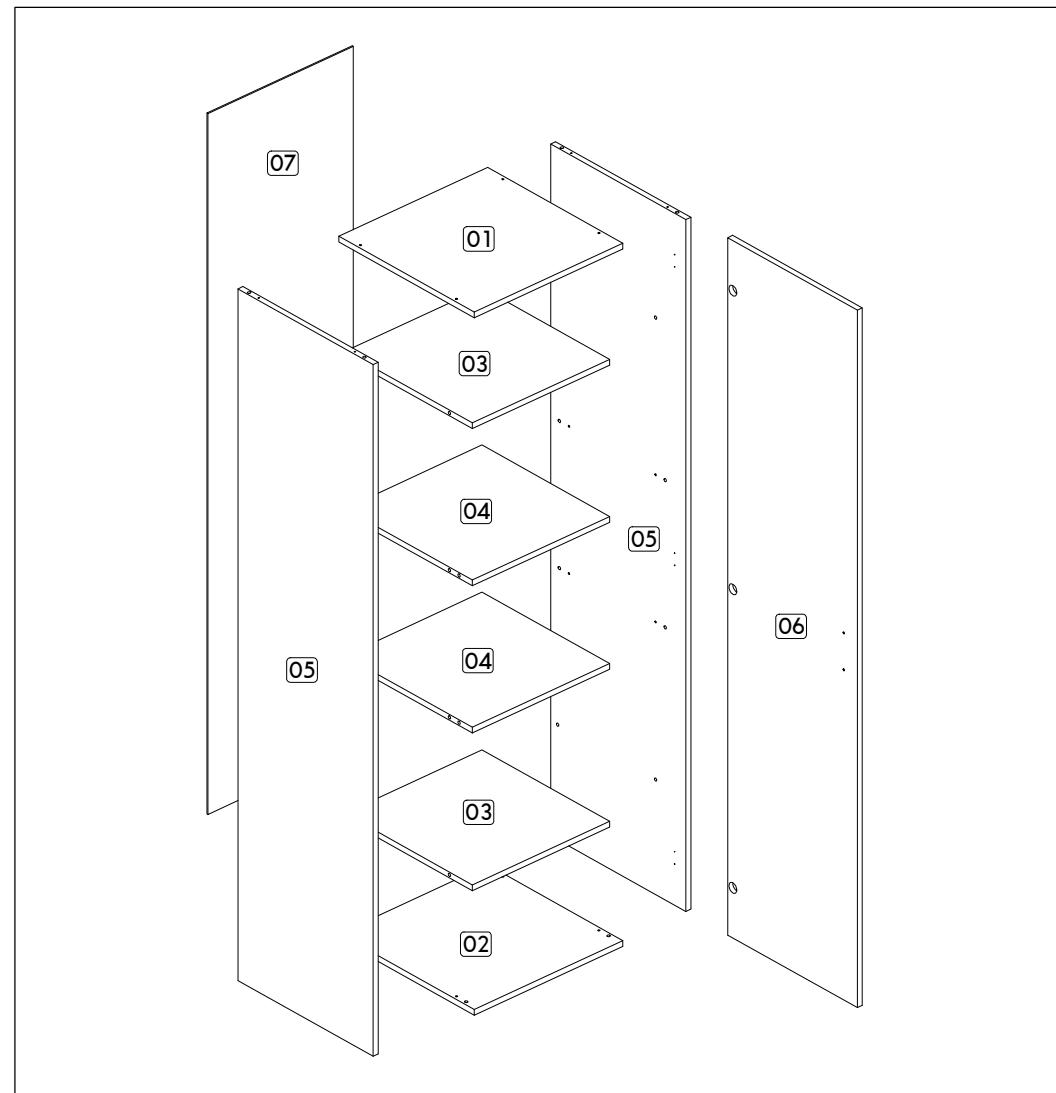

<b>Nº</b>	<b>DESCRIÇÃO - DESCRIPTION - DESCRIPCIÓN</b>	<b>MEDIDAS-MEASURES - MEDIDAS (mm)</b>	<b>QTD.</b>
01	<b>Base superior</b> - Top base - Base superior	450 x 450 x 15	01
02	<b>Base inferior</b> - Bottom base - Base inferior	450 x 450 x 15	01
03	<b>Prateleira</b> - Shelf - Repisa	425 x 416 x 15	02
04	<b>Base</b> - Base - Base	425 x 416 x 15	02
05	<b>Lateral direita/esquerda</b> - Right/left side- Lateral derecha/izquierda	1800 x 450 x 15	02
06	<b>Porta</b> - Door - Puerta	1815 x 431 x 15	01
07	<b>Costa</b> - Back - Fondo	1824 x 440 x 03	01

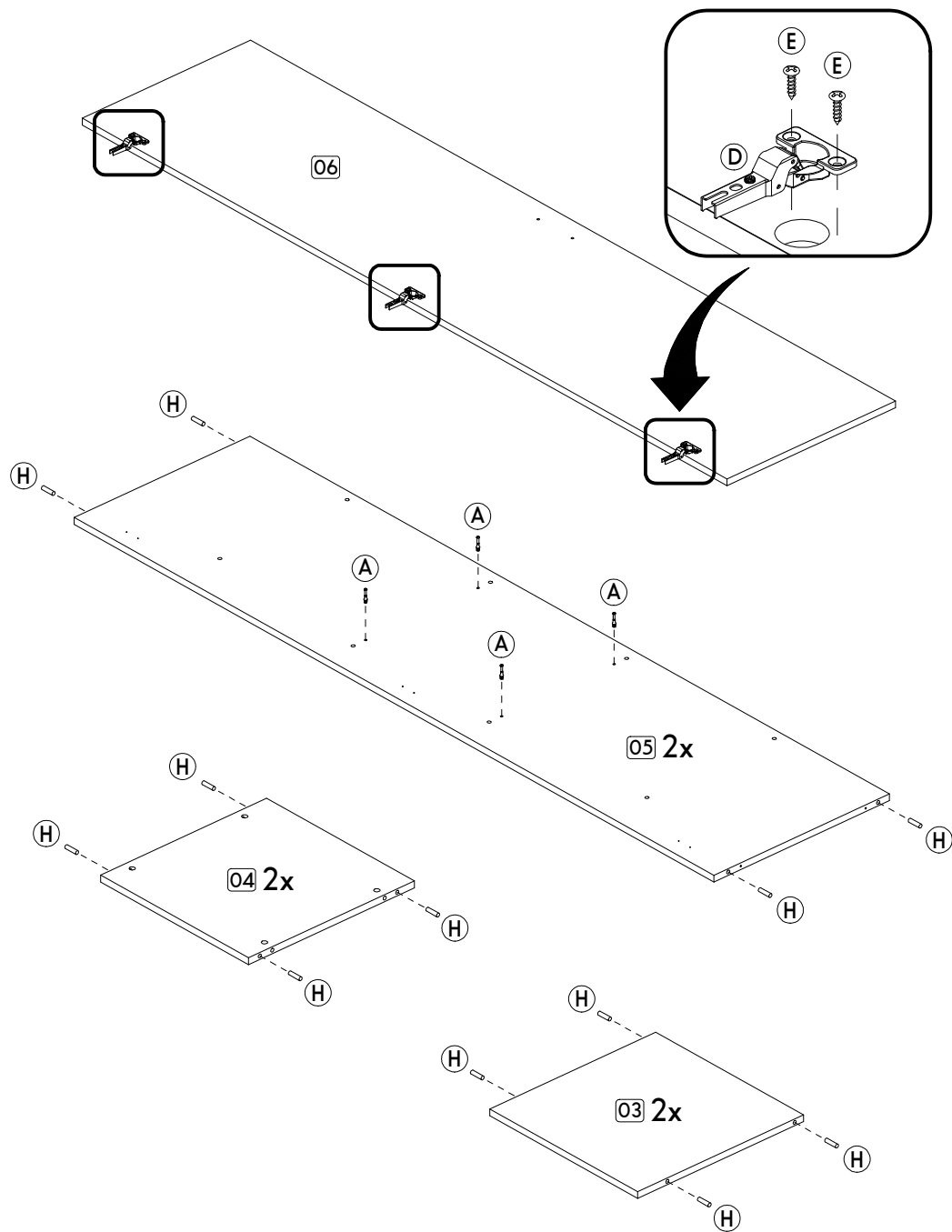

Passo/ Step/ Paso 01

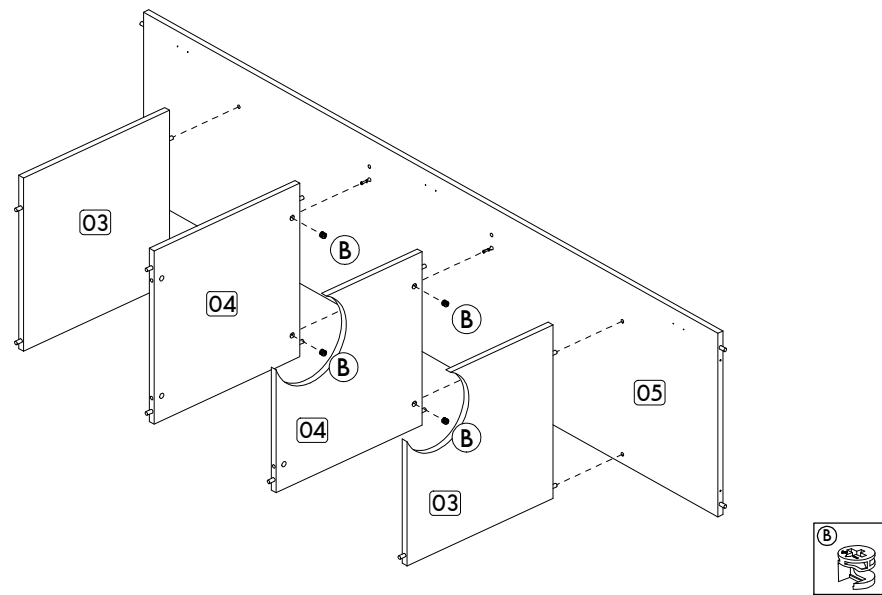

Passo/ Step/ Paso 02

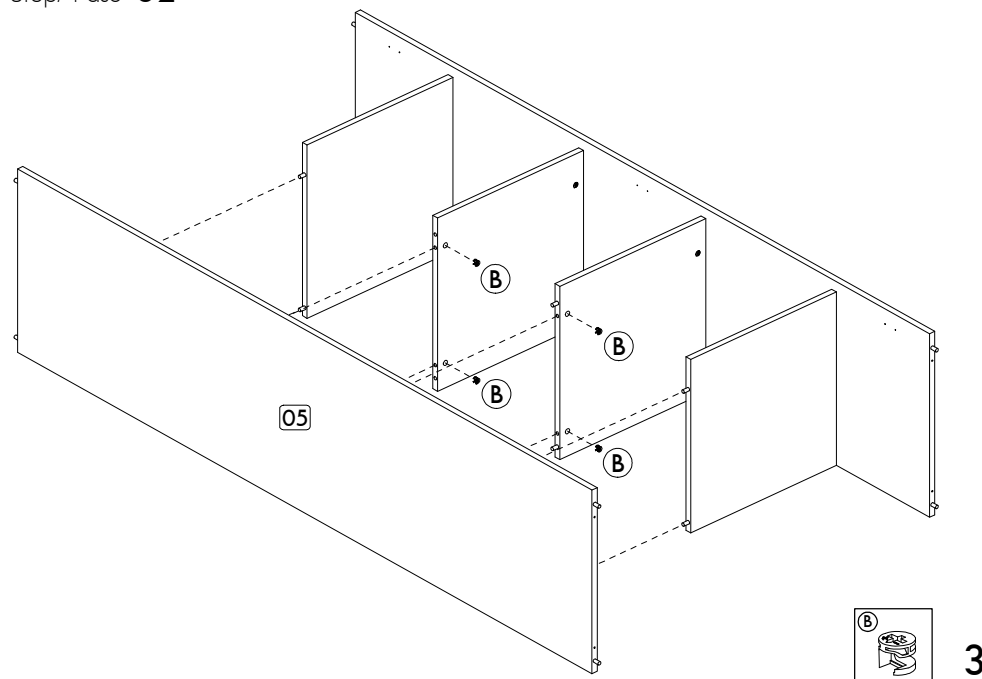

Passo/ Step/ Paso 03

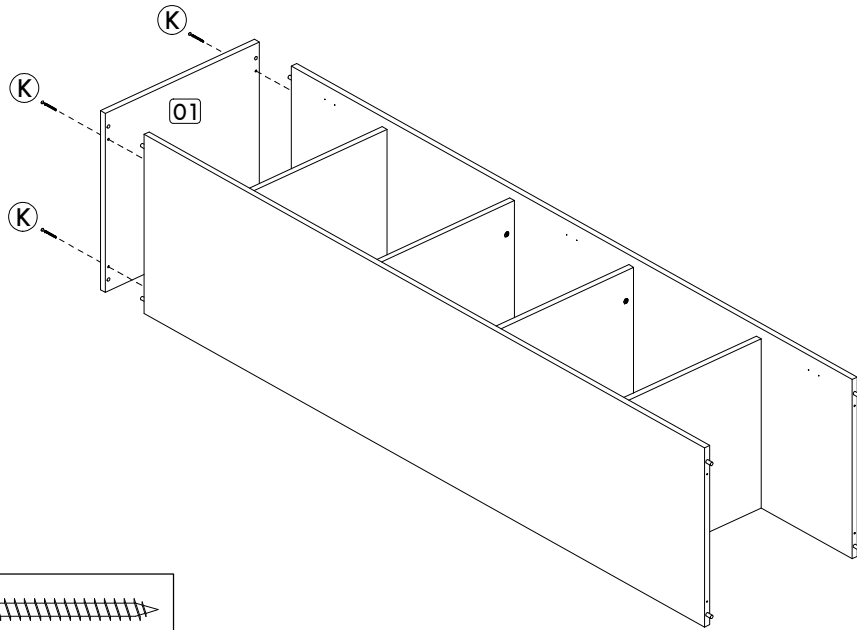

Passo/ Step/ Paso 04

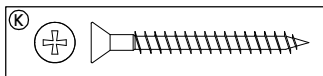
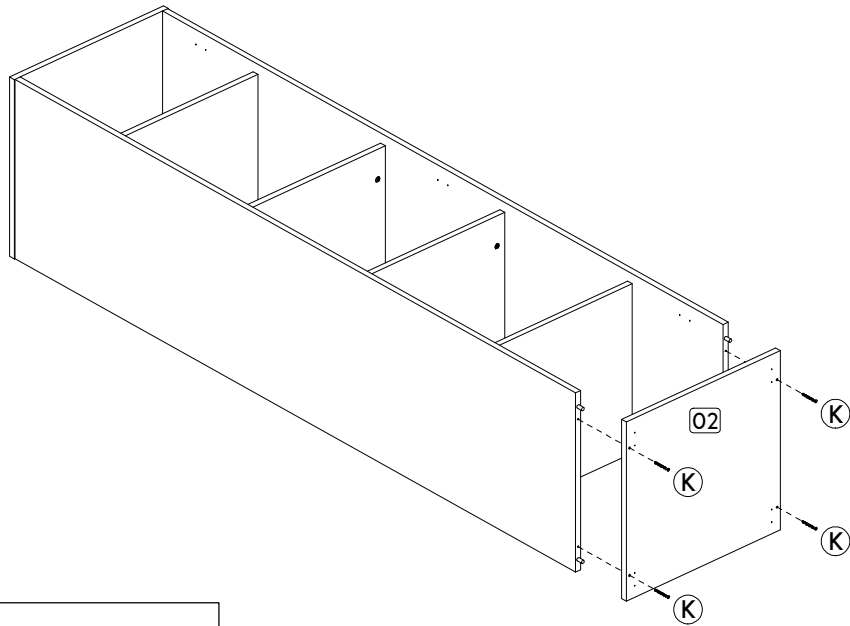

Passo/ Step/ Paso 05

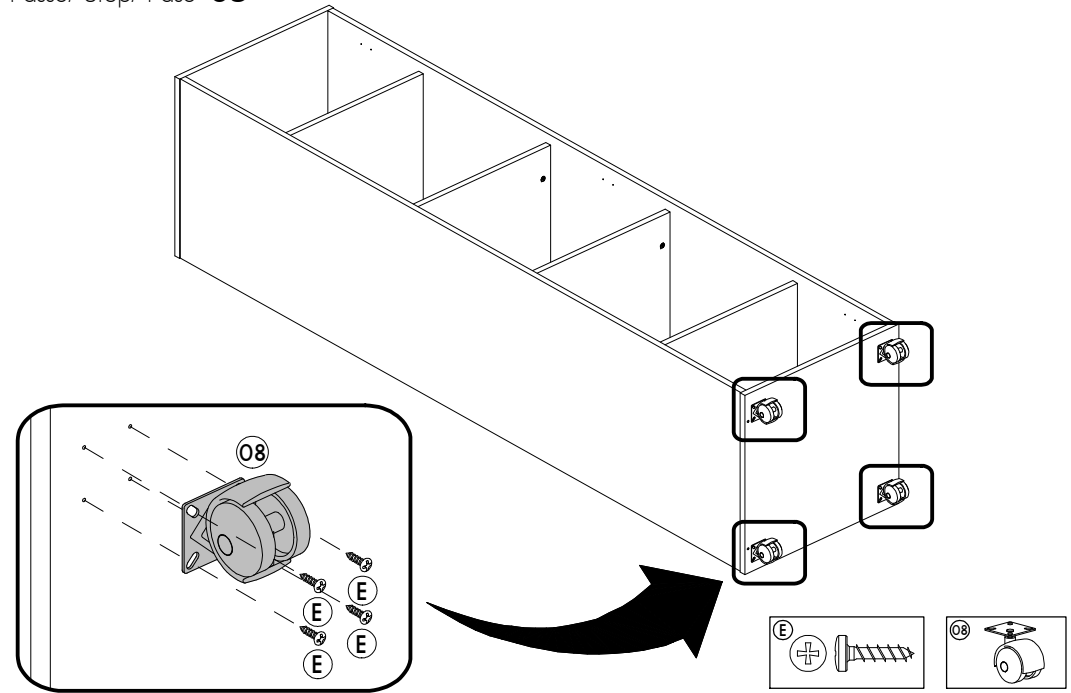

Passo/ Step/ Paso 06

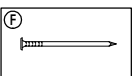
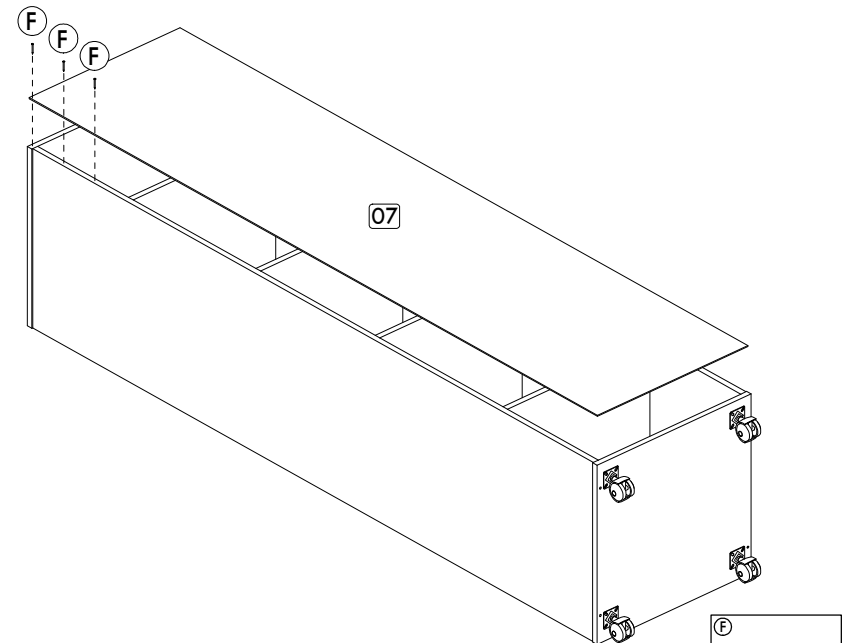

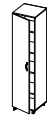

NOTA: Se optou por montar a porta para a direita, vá para a página 6.  
NOTE: If you chose to install the door to the right, go to page 6.  
NOTA: Si elegiste instalar la puerta a la derecha, ir a la página 6.

Passo/ Step/ Paso 07

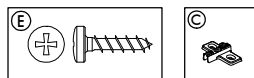
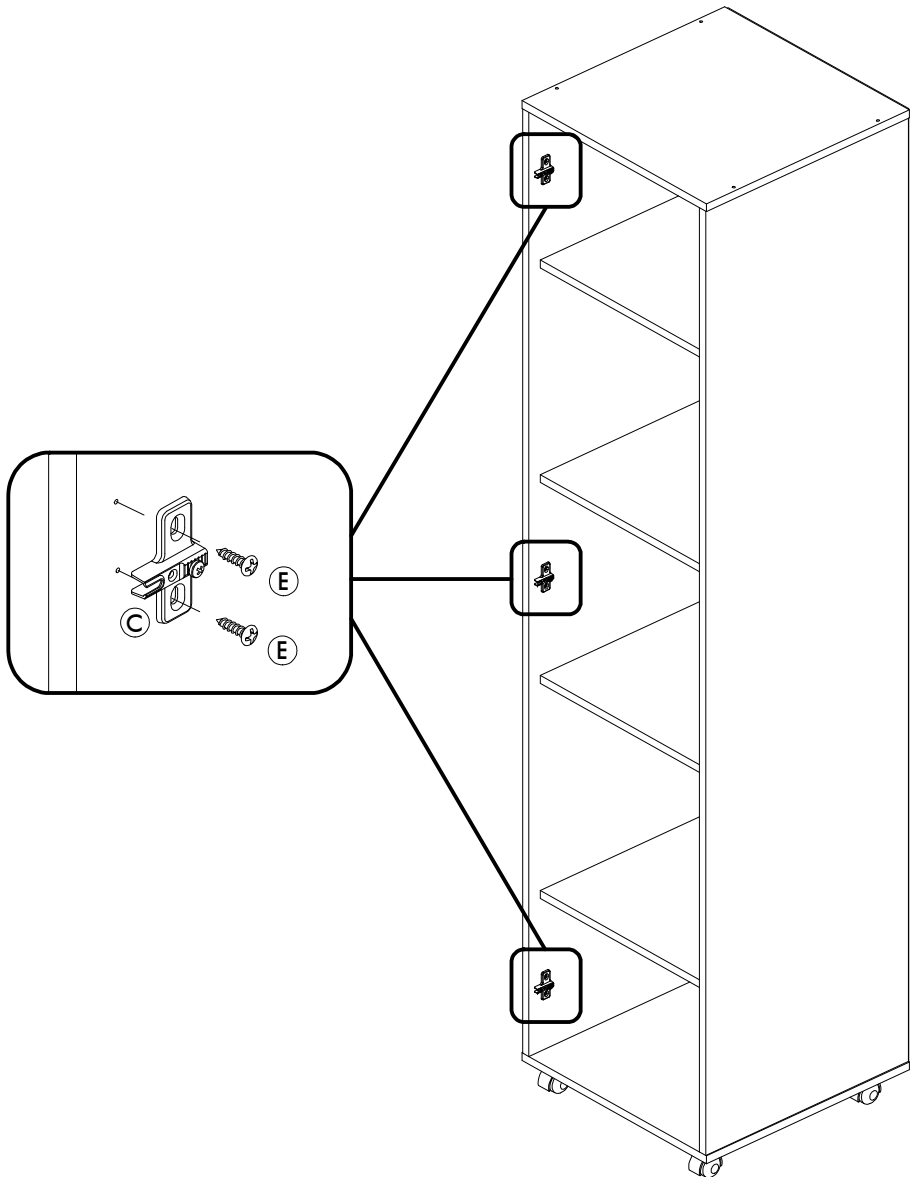

Passo/ Step/ Paso 08

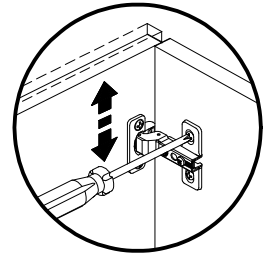
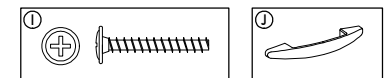
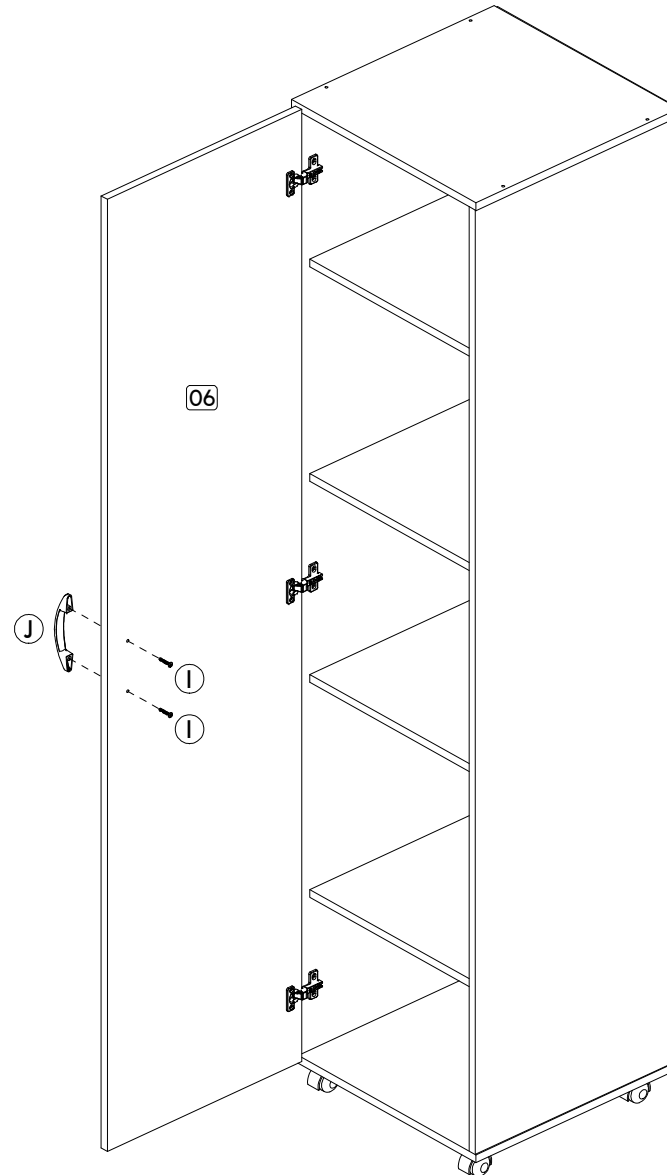

Regulagem Vertical  
Ajuste Vertical  
Vertical Adjustment

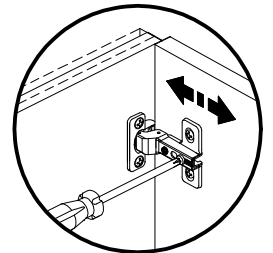

Regulagem Profundidade  
Ajuste Profundidad  
Depth Adjustment

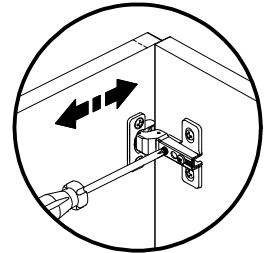

Regulagem Horizontal  
Ajuste Horizontal  
Horizontal Adjustment



Passo/ Step/ Paso 07

Passo/ Step/ Paso 08

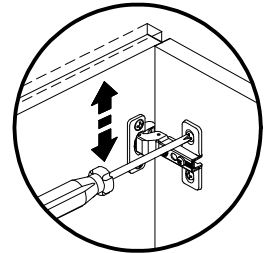
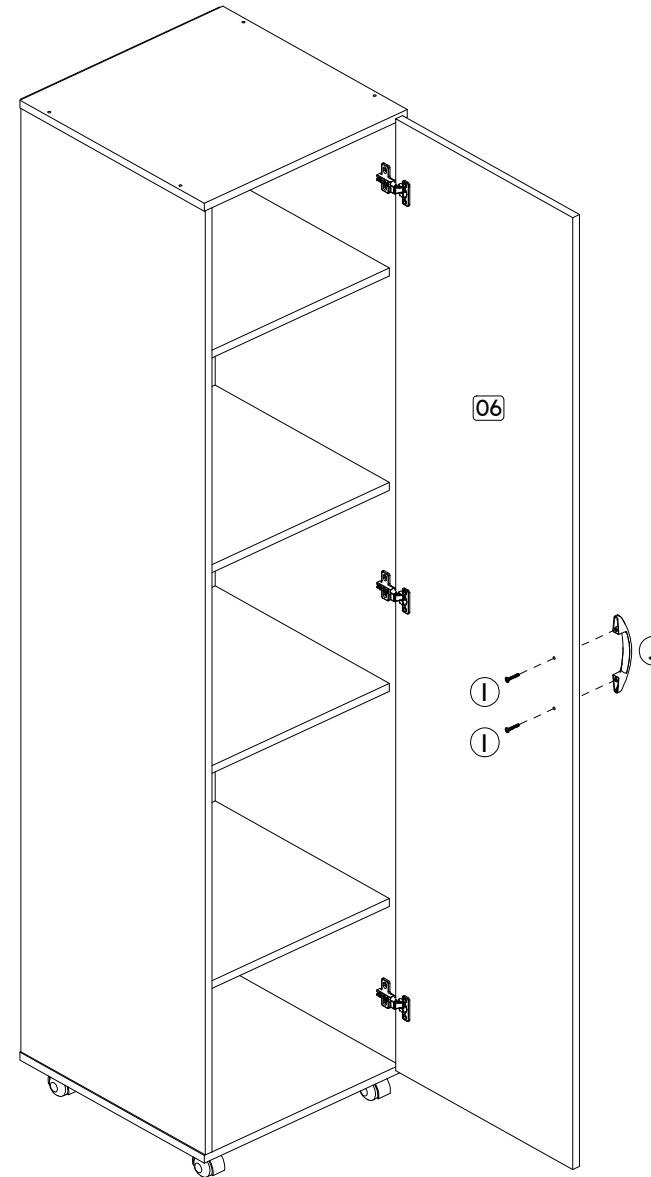
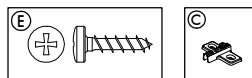
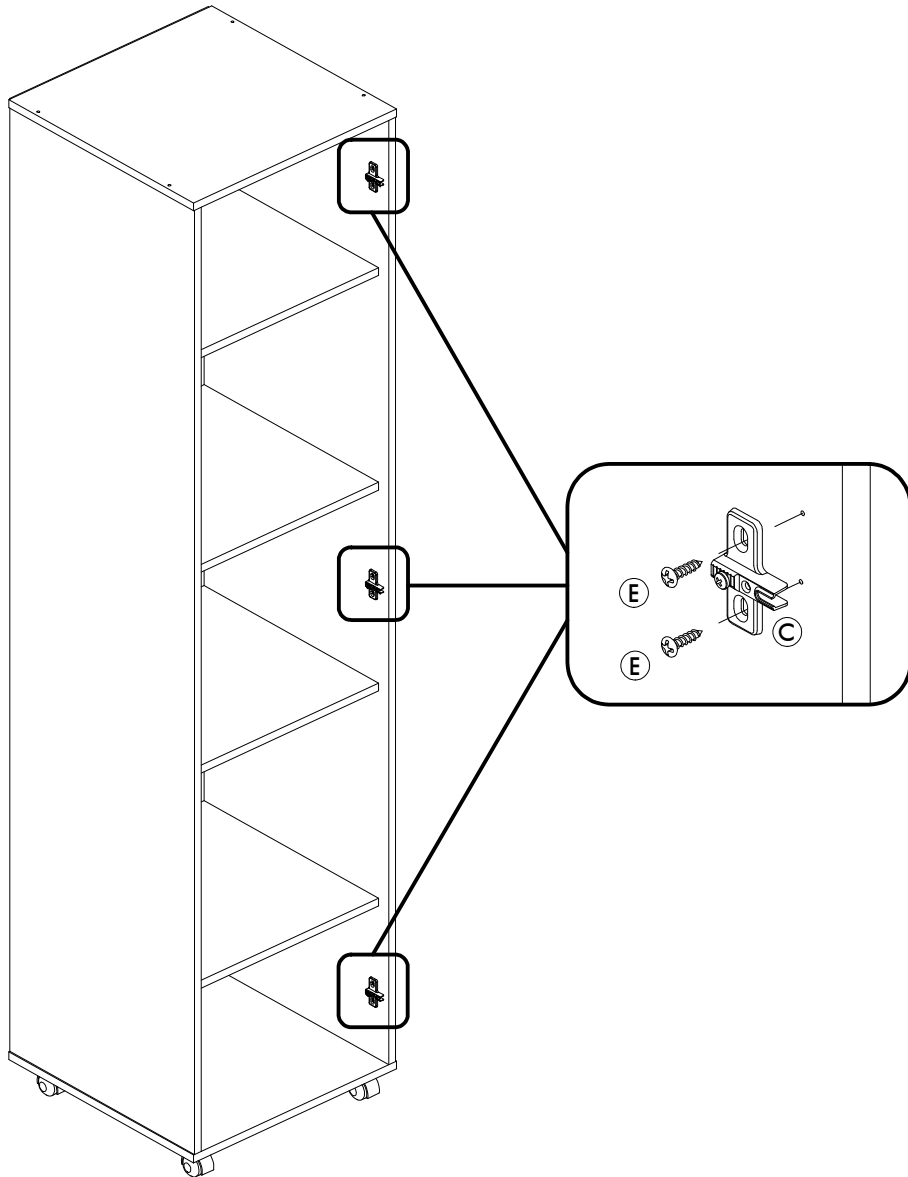

Regulagem Vertical  
Ajuste Vertical  
Vertical Adjustment

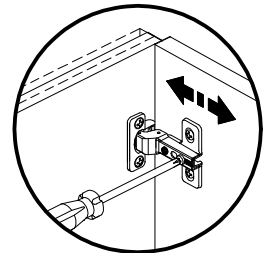

Regulagem Profundidade  
Ajuste Profundidad  
Depth Adjustment

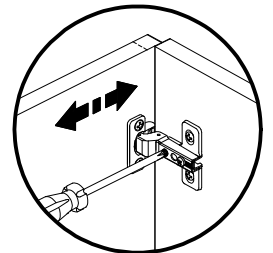

Regulagem Horizontal  
Ajuste Horizontal  
Horizontal Adjustment

