

Montagem da Gaveta

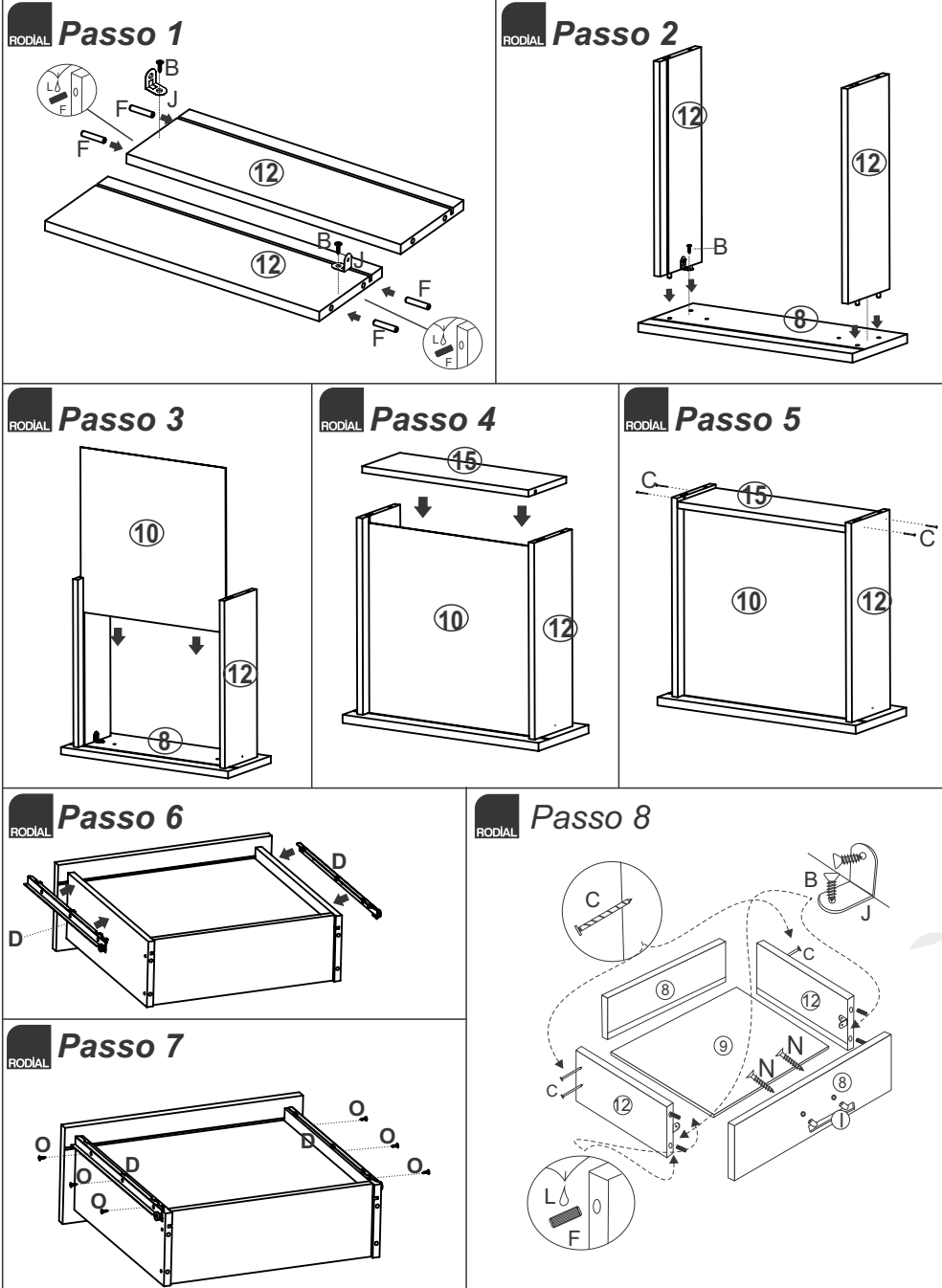

INSTRUÇÕES DE MONTAGEM
Instrucciones de armado

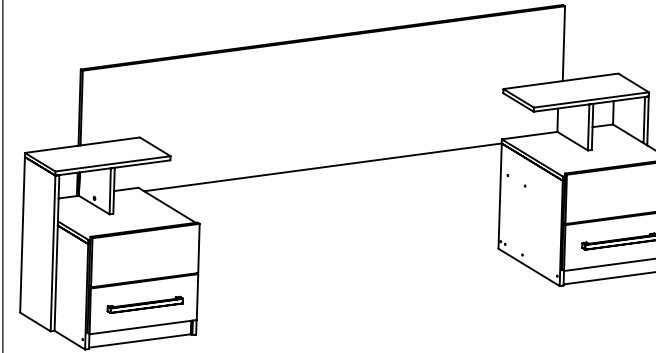

Cabeceira
cabecera

Ref.D84



www.rodial.com.br

Medida do colchão: 1,38 x1,88

Altura: **844** Largura: **2296** Profundidade: **480**
 Altura: anchô: profundidade:

Pessoas Necessárias para Montagem **Ferramentas para a montagem**
 (Não Fornecidas)

las personas necesarias para el montaje

Herramientas para el montaje (No se proporcionaron)

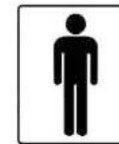

1 Pessoa
1 Persona



Martelo
martillo



Chave philips ou Parafusadeira
Destornillador Philips o una llave

ATENÇÃO

- Ler e observar atentamente toda a instrução antes de iniciar a montagem.
- A montagem do produto deverá ser feita em superfície limpa e plana.
- Aconselhamos utilizar a embalagem para forrar o chão a fim de não danificar o produto.
- Evitar batidas e o contato com objetos cortantes.

LIMPEZA

- Pano levemente umedecido com água seguido de pano seco.
- Não utilizar produtos químicos e abrasivos.

ATENCIÓN









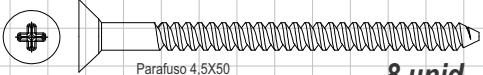

- Lea y siga todas las instrucciones cuidadosamente antes de iniciar el montaje.
- El montaje del producto debe estar en una superficie limpia y plana.
- Recomienda utilizar el embalaje para cubrir el suelo con el fin de no dañar producto.
- Eviten los golpes y el contacto con objetos punzantes.

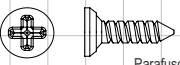
LIMPIEZA

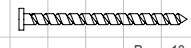
- Paño ligeramente humedecido con agua, seguido por un paño seco.
- No utilice productos químicos y abrasivos.

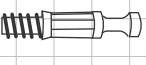
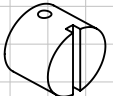
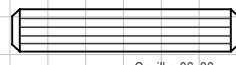
Relação de Acessórios

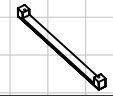
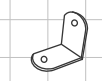
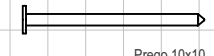
relación de las partes

A		Parafuso 4,5X50	8 unid.	N		Parafuso 3,5x25	4 unid.
B		Parafuso 3,5x12	24 unid.	O		Parafuso Corrediza metálica 3,5x12	48 unid.
C		Prego 13x13 Ardox	16 unid.	Q		Tambor	6 unid.
D		Corrediza metálica	04 unid.	R		Mini Fix	6 unid.
E		Porca plástica 12x9 Perno 4,5x50	8 unid.				
F		Cavilha 06x30	36 unid.				
G		Sapata plástica 15mm	08 unid.				
H		Parafuso 4,5X40	8 unid.				
I		Puxador	02 unid.				
J		Cantoneira metálica 18x18	12 unid.				
K		Prego 10x10	48 unid.				
L		Cola 10 gr	01 unid.				
M		Etiqueta logomarca	01 unid.				

Montagem da Gaveta Maior

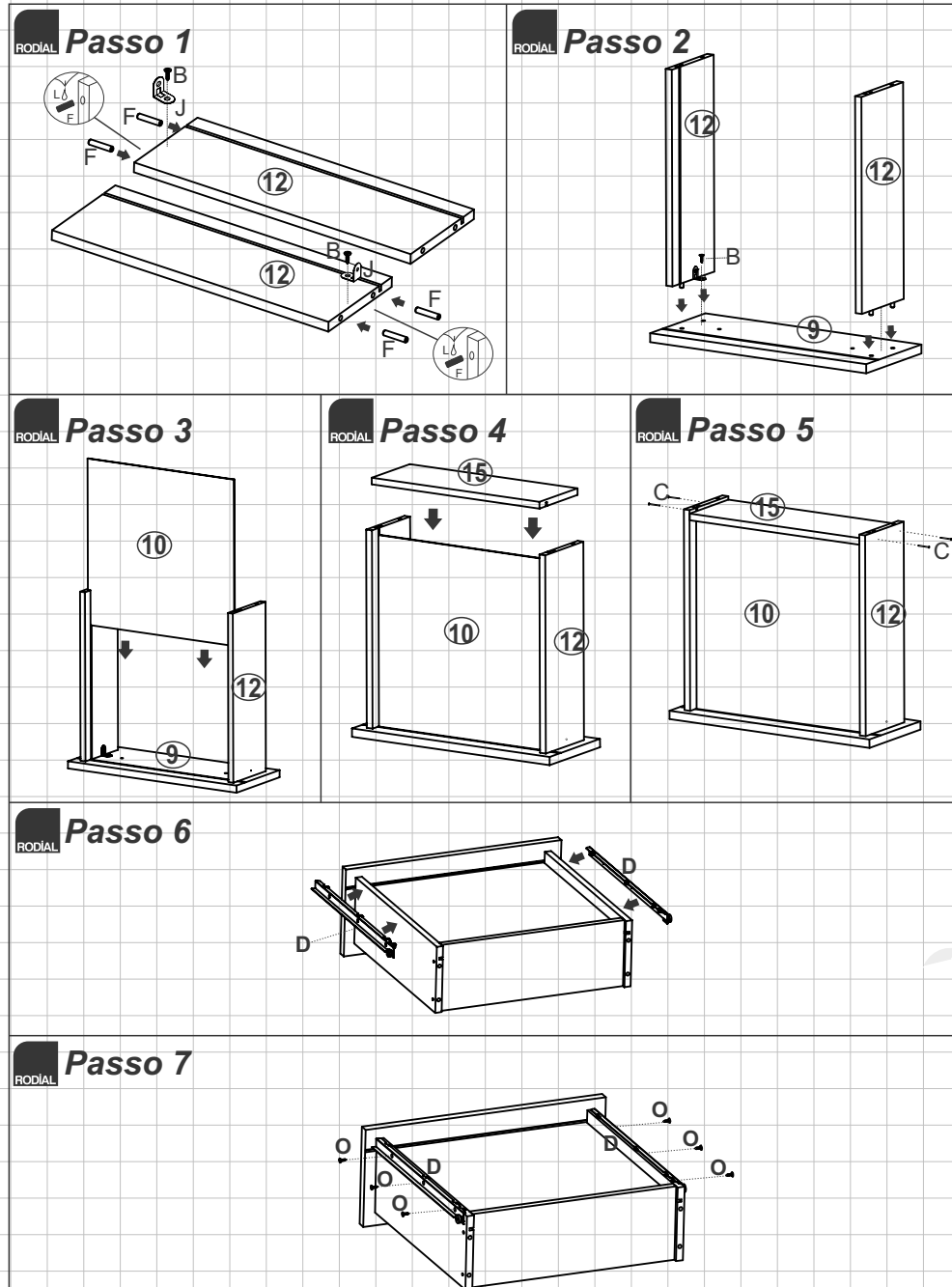

RODIAL Passo 4

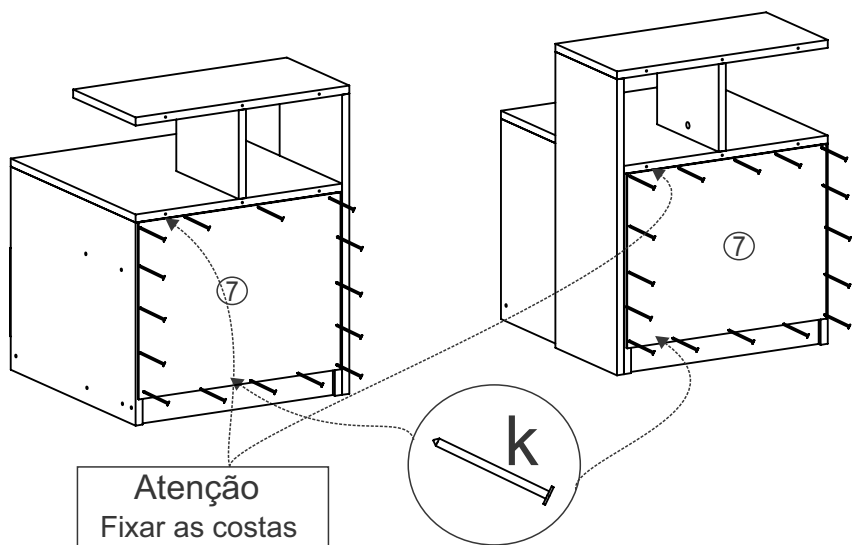

Atenção
Fixar as costas
abaixo do tampo
para fixar a
cabeceira

RODIAL Passo 5

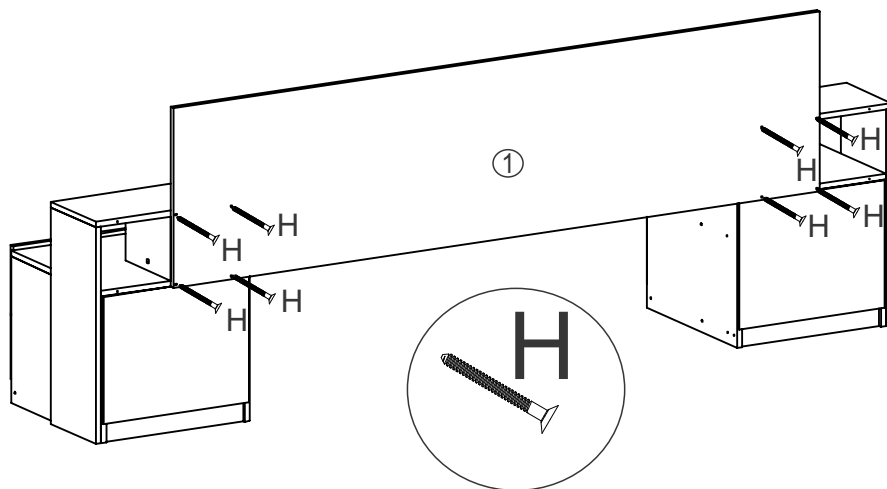

Relação de Peças
relación de las partes

Nº	Descrição	Material	Medida	Quant	Caixa
Nº	Descripción	Material	Medir	Cantidad	Caja
1	Cabeceira grande <i>Gran cama</i>	MDP MDP	1886x465x15	1	1
2	Divisão criada <i>División creada</i>	MDP MDP	166x225x15	2	2
3	Lateral Criadol <i>lateral</i>	MDP MDP	560x225x15	2	1
4	Tampo <i>cabeza</i>	MDP MDP	445x225x15	2	1
5	Tampo direito <i>la cabeza derecho</i>	MDP MDP	430x450x15	1	1
6	Tampo esquerdo <i>cabeza izquierda</i>	MDP MDP	430x450x15	1	1
7	Costa <i>Costa</i>	MDP MDP	420x340x3	2	2
8	Frente Gaveta <i>Frente del cajón</i>	MDP MDP	415x165x15	2	2
9	Frente Gaveta <i>Frente del cajón</i>	MDP MDP	415x177x15	2	2
10	Fundo de Gaveta <i>Fondo de cajón</i>	MDP MDP	360x354x3	4	2
11	Lateral <i>lateral</i>	MDP MDP	379x450x15	4	2
12	Lateral de Gaveta <i>Cajón Side</i>	MDP MDP	360x125x12	8	2
13	Rodapé Frontal <i>pie delante</i>	MDP MDP	400x60x15	2	2
14	Rodapé Traseiro <i>pie trasero</i>	MDP MDP	400x60x15	2	2
15	Traseiro de gaveta <i>Cajón trasero</i>	MDP MDP	352x125x12	4	2

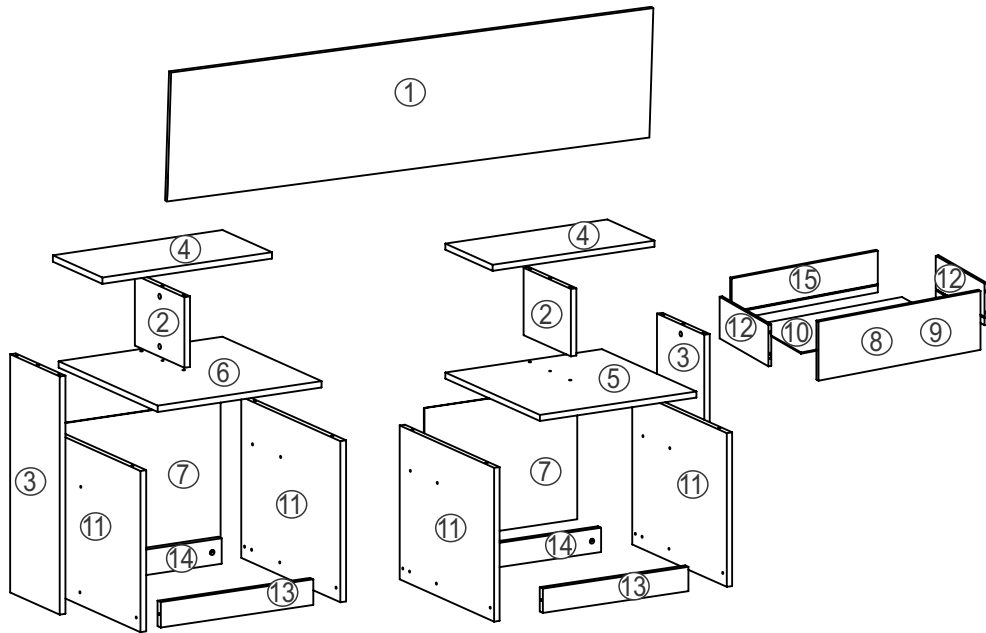

Passo 1

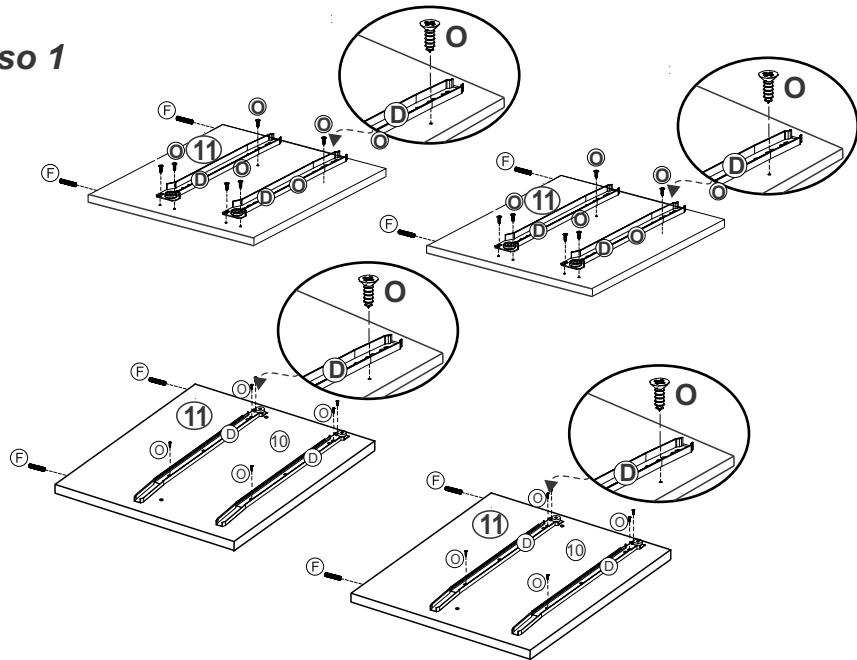

Passo 2

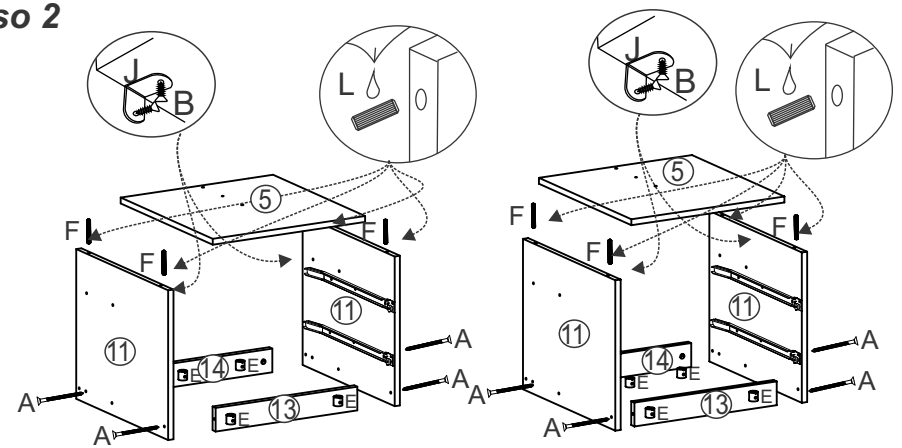

Passo 3

