

## SAPATEIRA 3 GAVETAS

Shoes storage 3 drawers  
Zapatero 3 cajones

Código **3006** | Revisão 10

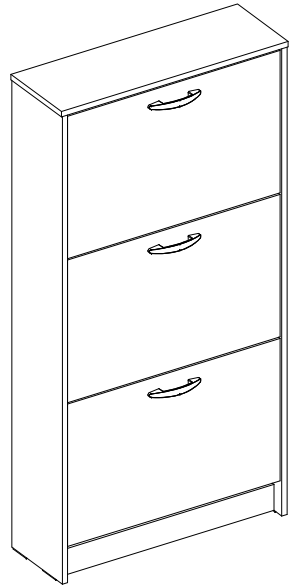

### PESO MÁXIMO SUPORTADO PELAS PEÇAS, SENDO ESTE DISTRIBUÍDO UNIFORMEMENTE.

Maximum weight supported by parts, being this evenly distributed.  
Peso máximo soportado por las partes, siendo esta distribuido uniformemente.

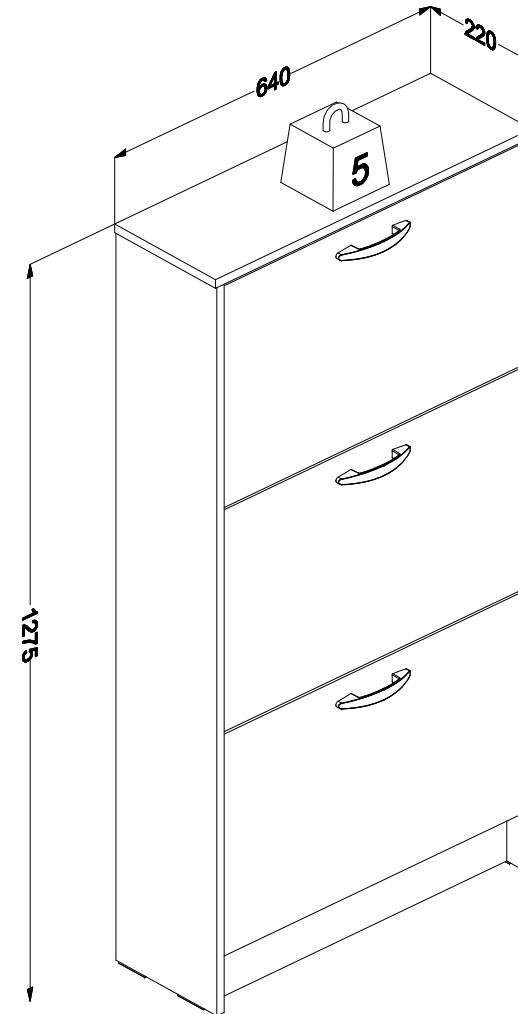

### Você vai precisar de/ You will need / Usted necesitará

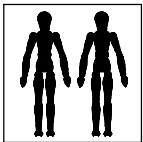

2 Pessoas  
2 people  
2 personas

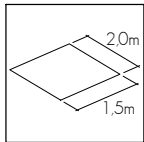

Espaço recomendado para montagem  
Recommended space for assemble  
Espacio recomendado para el armado

### Ferramentas não inclusas Tools not included / Herramientas no incluidas

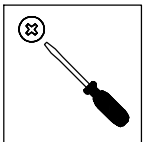

Chave Philips  
Screwdriver  
Destornillador cruz



Martelo  
Hammer  
Martillo

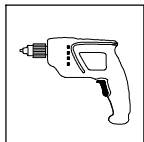

Furadeira  
Drilling machine  
Taladro

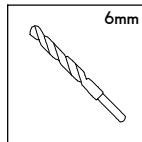

Broca  
Drill bit  
Taladro









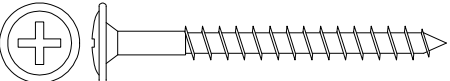
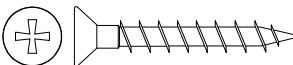

\* PESO EM KG/Weight in Kg/ Peso en Kg  
DIMENSÕES EM MM/Dimensions in mm/ Dimensiones en mm

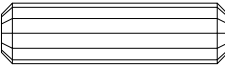
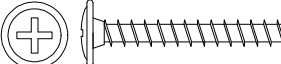
**IDENTIFICAÇÃO DOS ACESSÓRIOS/ IDENTIFICATION OF ACCESSORIES/ IDENTIFICACIÓN DE ACCESORIOS**

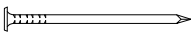
**NOTAS:** A separação dos acessórios antes de iniciar a montagem facilitará a mesma. Os parafusos e cavilhas estão na escala real. Em caso de dúvida na identificação, coloque o acessório sobre a imagem.

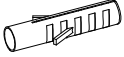
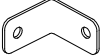
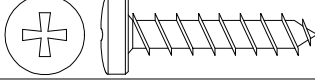
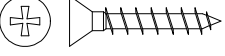
**NOTES:** The separation of the accessories before you start the assembly will facilitate the same. The screws and dowels are in real scale. In case of doubts about the identification, place the accessory on the image.

**NOTAS:** La separación de los accesorios antes de comenzar el armado facilitará el mismo. Los tornillos y taquetes son en escala real. En caso de dudas sobre la identificación, coloque el accesorio en la imagen.

<b>A</b>		<b>Parafuso flangeado</b> Flanged head screw Tornillo de cabeza flangeada	4,5x45mm	<b>04</b>	<b>P</b>		<b>Parafuso chato</b> Flat head screw Tornillo de cabeza plana	4,0x30 mm	<b>02</b>
<b>B</b>		<b>Parafuso chato</b> Flat head screw Tornillo de cabeza plana	3,5x14 mm	<b>40</b>	<b>10</b>		<b>Perfil H</b> Profile Perfil H	1205 mm	<b>01</b>
<b>C</b>		<b>Cavilha</b> Wooden Dowel Pin	8x30 mm	<b>08</b>					
<b>D</b>		<b>Parafuso flangeado</b> Flanged head screw Tornillo de cabeza flangeada	3,5x25 mm	<b>06</b>					
<b>E</b>		<b>Sapata</b> Plastic foot Pie plástico	15x58 mm	<b>04</b>					
<b>F</b>		<b>Prego</b> Nail Clavo	10 x10	<b>40</b>					
<b>G</b>		<b>Puxador</b> Handle Tirador	96 mm	<b>03</b>					
<b>H</b>		<b>Bucha</b> Bushing Tapón	6 mm	<b>02</b>					
<b>I</b>		<b>Cantoneira de metal</b> Metal bracket Soporte de metal	22x22 mm	<b>06</b>					
<b>J</b>		<b>Parafuso panela</b> Pan head screw Tornillo de pan	5,5x25 mm	<b>06</b>					
<b>K</b>		<b>Parafuso chato</b> Flat head screw Tornillo de cabeza plana	3,5x20 mm	<b>06</b>					
<b>L</b>		<b>Articulador</b> Articulator Articulador	-	<b>06</b>					
<b>M</b>		<b>Pino fixador</b> Pin fastener Clavija fijador	-	<b>06</b>					
<b>N</b>		<b>Pino suporte</b> Pin support Clavija soporte	-	<b>06</b>					
<b>O</b>		<b>Batente</b> Stop Batiente	-	<b>06</b>					

IDENTIFICAÇÃO DAS PEÇAS/ PARTS IDENTIFICATION/ IDENTIFICACIÓN DE LAS PIEZAS

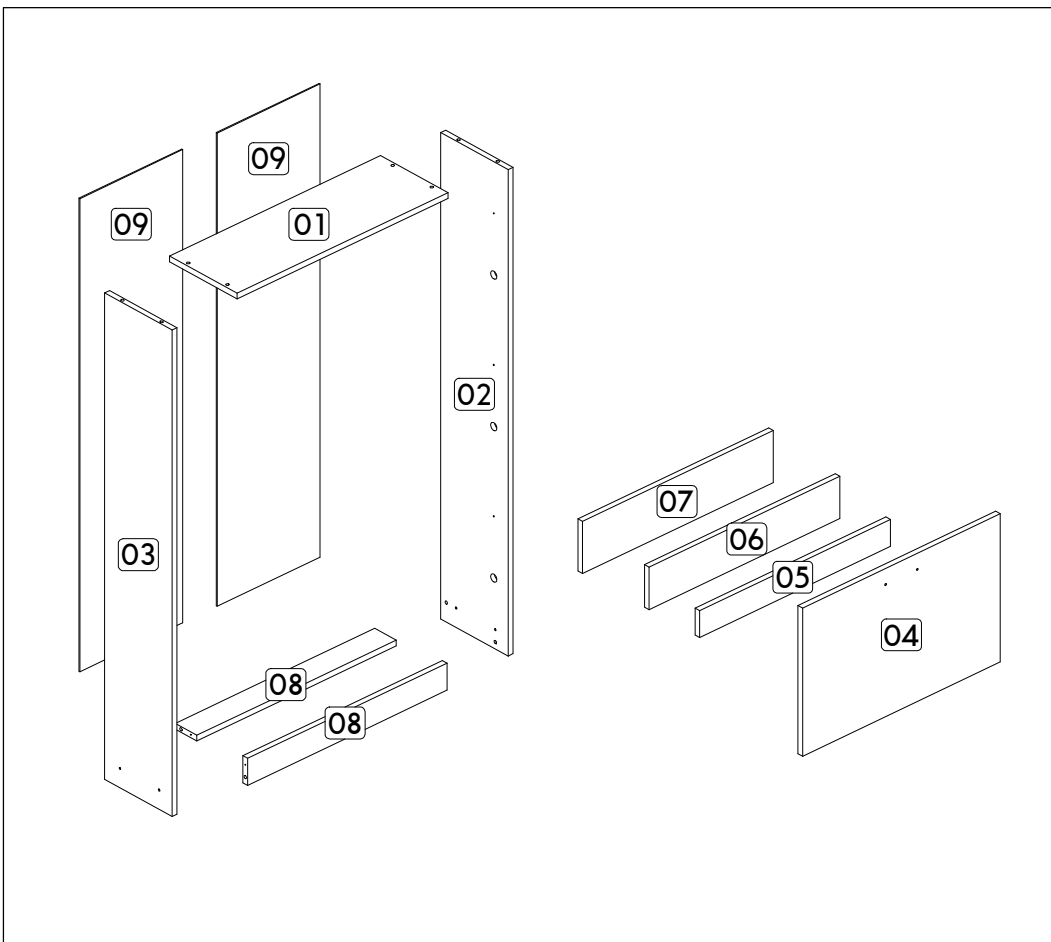

Nº	DESCRIÇÃO - DESCRIPTION - DESCRIPCIÓN	MEDIDAS - MEASURES - MEDIDAS (mm)	QTD.
01	Base superior - Top base - Base superior	640 x 220 x 15	01
02	Lateral direita - Right side - Lateral derecha	1260 x 220 x 15	01
03	Lateral esquerda - Left side - Lateral izquierda	1260 x 220 x 15	01
04	Frente gaveta - Drawer front - Frente del cajón	384 x 600 x 15	03
05	Base menor - Small base - Base menor	579 x 70 x 15	03
06	Base intermediária - Intermediate base - Base del medio	579 x 110 x 15	03
07	Base maior - Large base - Base mayor	579 x 135 x 15	03
08	Rodapé - Footer - Rodapie	605 x 70 x 15	02
09	Costa - Back - Fondo	1226 x 312 x 03	02

PRÉ-MONTAGEM/ PRE-ASSEMBLE/ PRE ARMADO

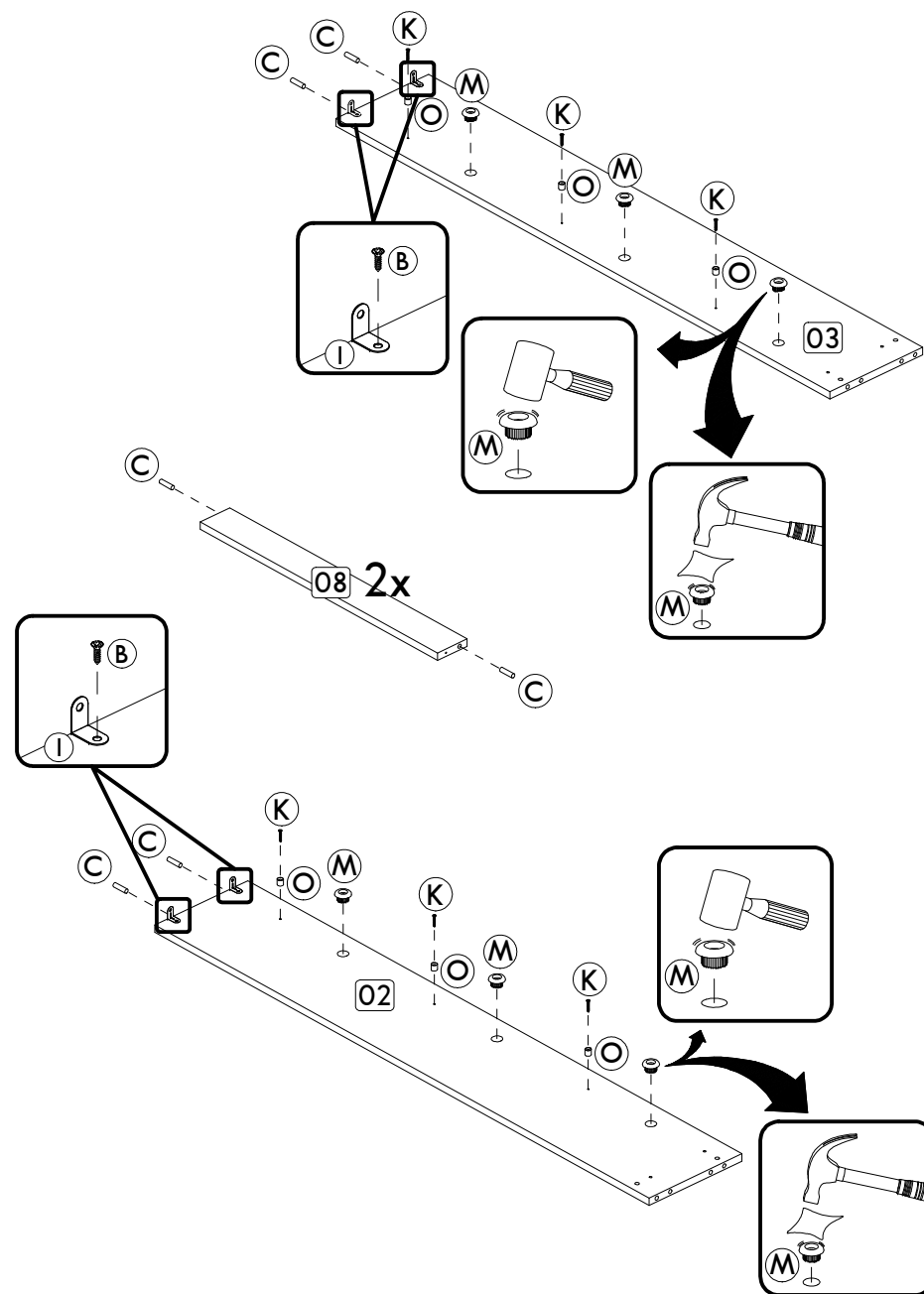

Passo/ Step/ Paso 01

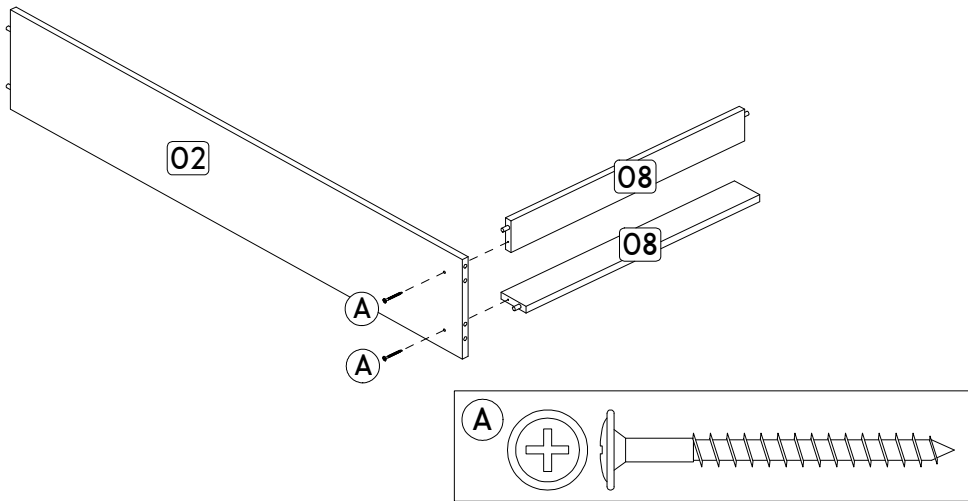

Passo/ Step/ Paso 02

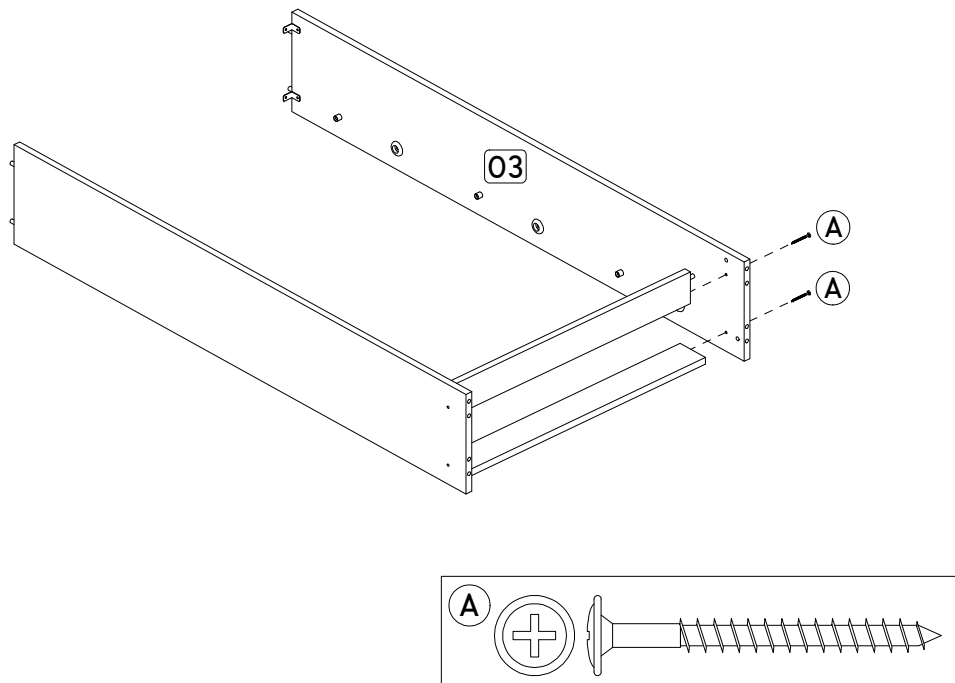

Passo/ Step/ Paso 03

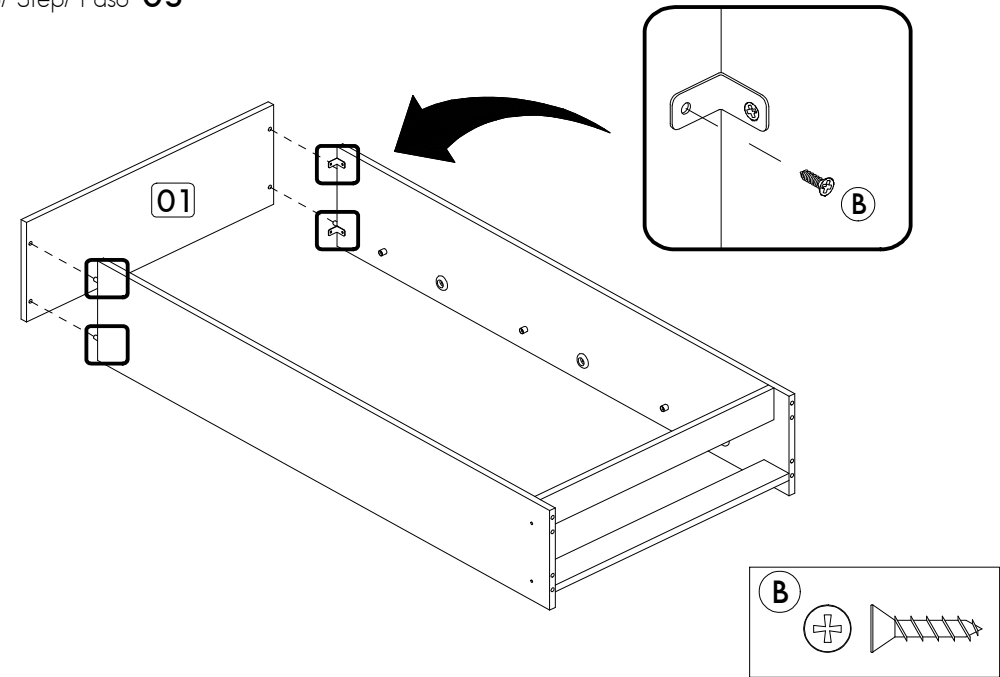

Passo/ Step/ Paso 04

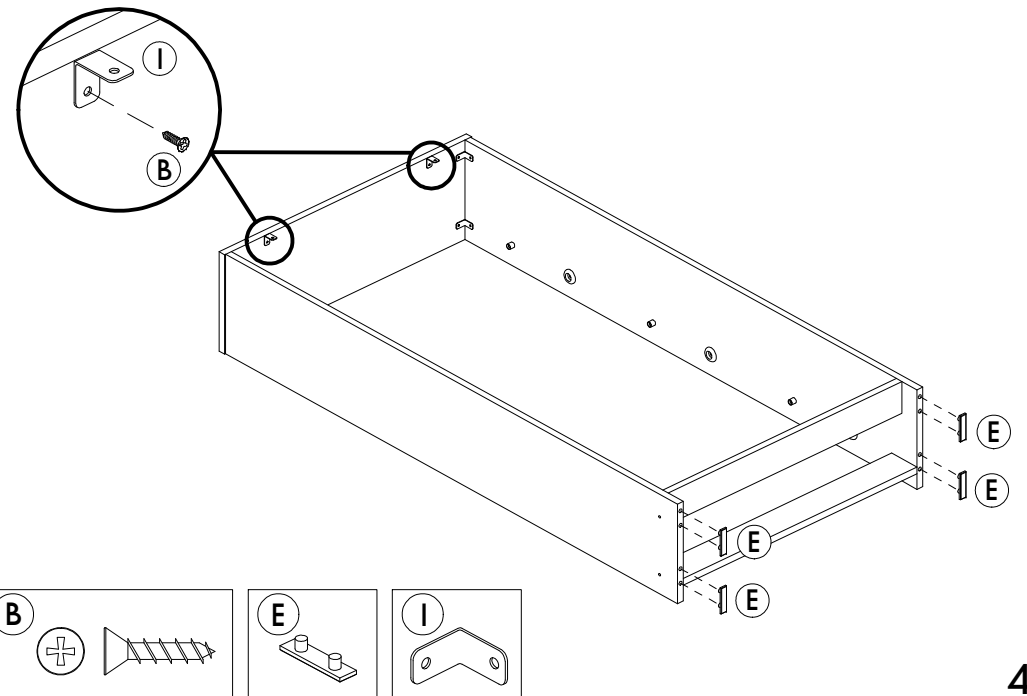

Passo/ Step/ Paso 05

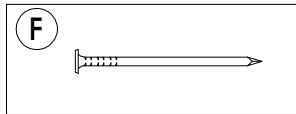
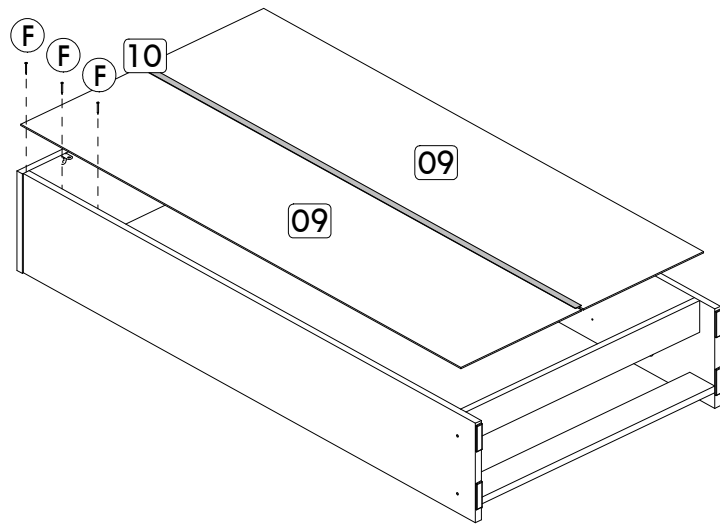

Passo/ Step/ Paso 06

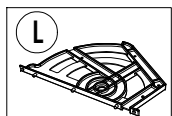
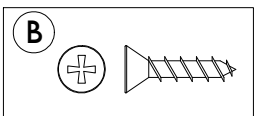
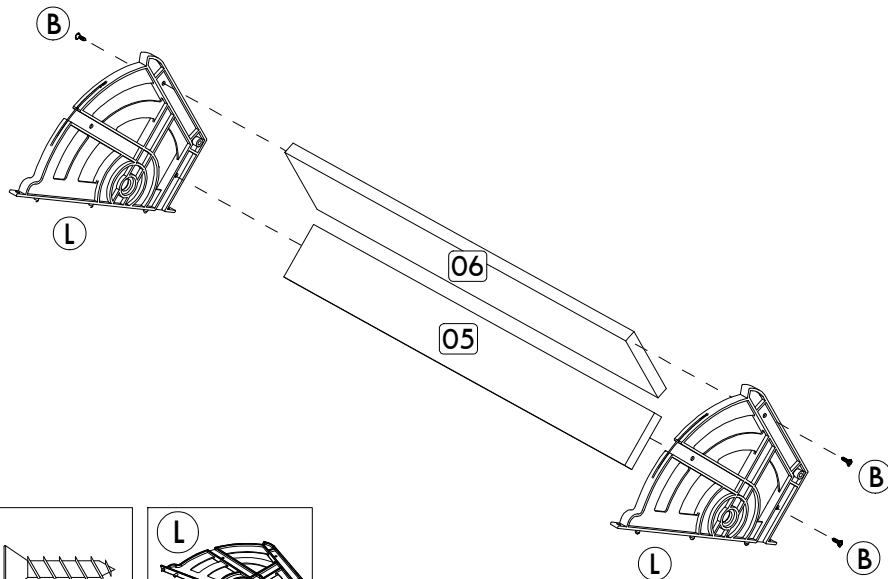

Passo/ Step/ Paso 07

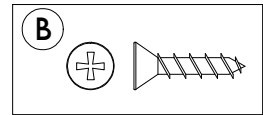
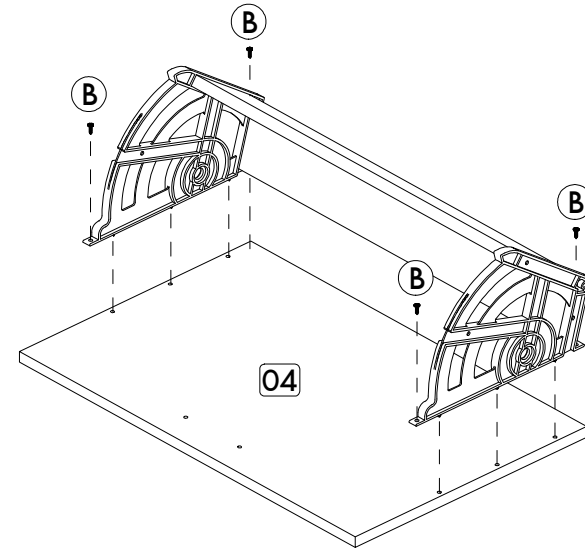

Passo/ Step/ Paso 08

