

## ESTANTE OURO PRETO - 6 NICHOS

Bookcase **Ouro Preto** - 6 niches  
Estantería **Ouro Preto** - 6 nichos

Código **2427** | Revisão 03

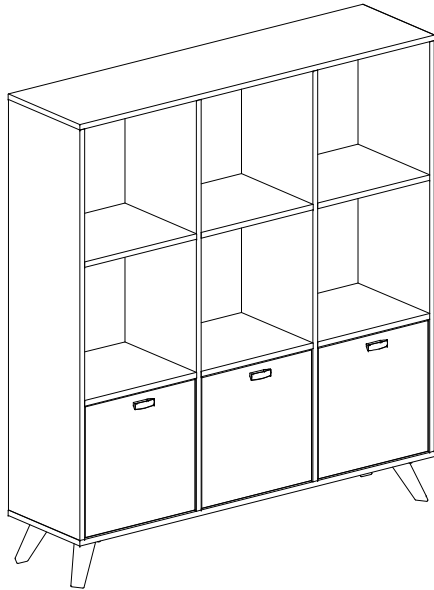

**PESO MÁXIMO SUPORTADO PELAS PEÇAS, SENDO ESTE DISTRIBUÍDO UNIFORMEMENTE.**

Maximum weight supported by parts, being this evenly distributed.

Peso máximo soportado por las partes, siendo esta distribuido uniformemente.

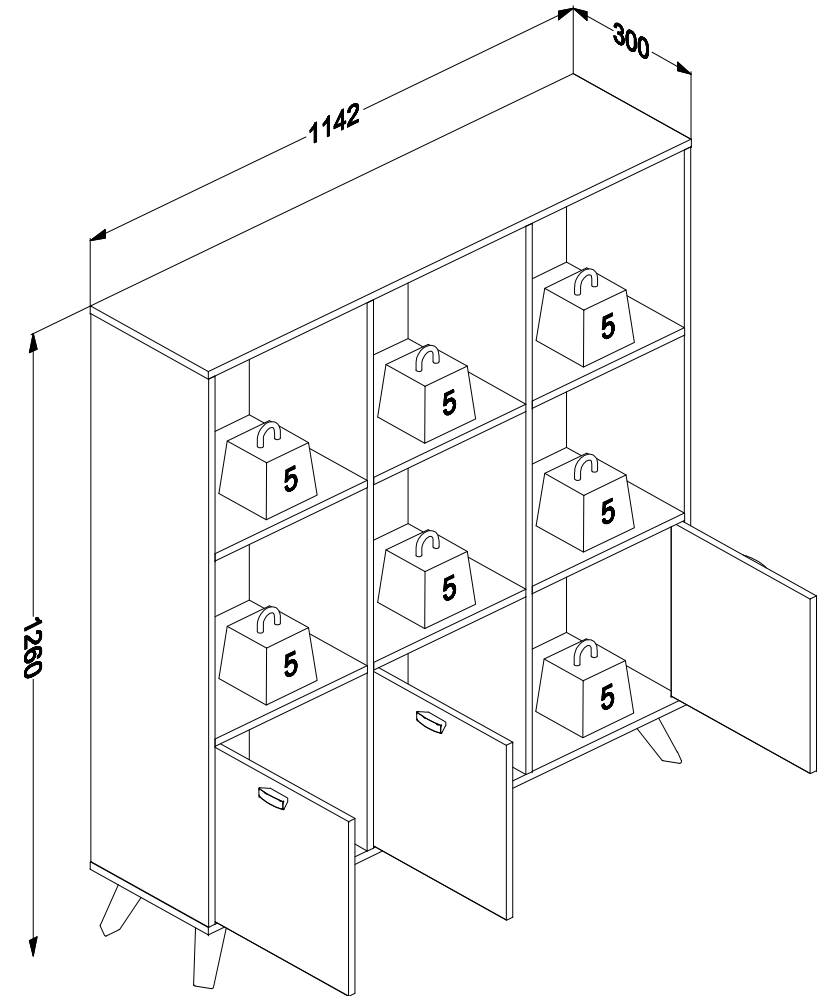

Você vai precisar de/ You will need / Usted necesitará

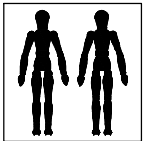

2 Pessoas  
2 People  
2 Personas

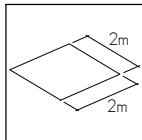

**Espaço recomendado para montagem**  
Recommended space for assemble  
Espacio recomendado para el armado

**Ferramentas não inclusas**  
Tools not included / Herramientas no incluidas

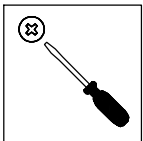

**Chave Philips**  
Screwdriver  
Destornillador cruz

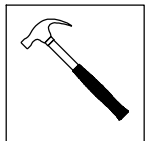

**Martelo**  
Hammer  
Martillo









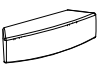

\* **PESO EM KG/** Weight in Kg/ Peso en Kg  
**DIMENSÕES EM MM/** Dimensions in mm/ Dimensiones en mm

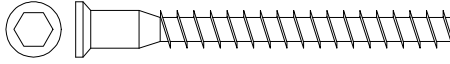
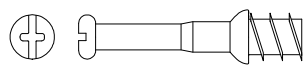
**IDENTIFICAÇÃO DOS ACESSÓRIOS/ IDENTIFICATION OF ACCESSORIES/ IDENTIFICACIÓN DE ACCESORIOS**

**NOTAS:** A separação dos acessórios antes de iniciar a montagem facilitará a mesma. Os parafusos e cavilhas estão na escala real. Em caso de dúvida na identificação, coloque o acessório sobre a imagem.

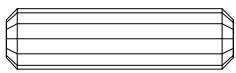
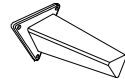
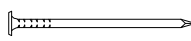
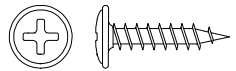
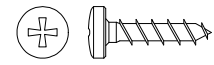
**NOTES:** The separation of the accessories before you start the assembly will facilitate the same. The screws and dowels are in real scale. In case of doubts about the identification, place the accessory on the image.

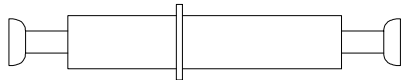
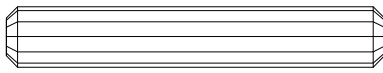
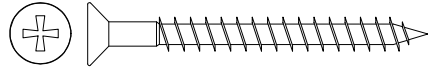
**NOTAS:** La separación de los accesorios antes de comenzar el armado facilitará el mismo. Los tornillos y taquetes son en escala real. En caso de dudas sobre la identificación, coloque el accesorio en la imagen.

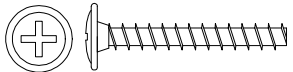
<b>A</b>		<b>Dobradiça super alta</b> Metal hinge super high Bisagra alta	26mm	<b>06</b>	<b>P</b>		<b>Puxador</b> Handle Tirador	-	<b>03</b>
<b>B</b>		<b>Calço dobradiça</b> Hinge shim Bisagra de calce	-	<b>06</b>	<b>Q</b>		<b>Parafuso estrutural</b> Structural screw Tornillo estructural	5,0x50 mm	<b>04</b>
<b>C</b>		<b>Haste minifix simples</b> Simple minifix screw Tornillo minifix simple	-	<b>04</b>	<b>R</b>		<b>Tampa parafuso estrutural</b> Structural screw cover Tapa tornillo estructural	-	<b>04</b>
<b>D</b>		<b>Tambor minifix</b> Drum lock Tambor minifix	12 mm	<b>12</b>	<b>S</b>		<b>Chave allen</b> Allen key Llave Allen	-	<b>01</b>
<b>E</b>		<b>Cavilha</b> Wooden Dowel Pin	8x30 mm	<b>24</b>	<b>13</b>		<b>Sapata</b> Plastic Foot Pie Plástico	-	<b>04</b>
<b>F</b>		<b>Prego</b> Nail Clavo	10 x10	<b>50</b>					
<b>G</b>		<b>Parafuso flangeado</b> Flanged head screw Tornillo de cabeza flangeada	3,5x16 mm	<b>12</b>					
<b>H</b>		<b>Parafuso panela</b> Pan head screw Tornillo de pan	3,5x14 mm	<b>27</b>					
<b>I</b>		<b>Tapa furo adesivo</b> Bore patch adhesive Tapones adhesivo	-	<b>04</b>					
<b>J</b>		<b>Suporte de prateleira</b> Shelf bracket Soporte de repisa	10x15 mm	<b>03</b>					
<b>K</b>		<b>Haste minifix dupla</b> Double minifix screw Tornillo minifix doble		<b>04</b>					
<b>L</b>		<b>Cavilha</b> Wooden Dowel Pin	8x50 mm	<b>08</b>					
<b>M</b>		<b>Parafuso chato</b> Flat head screw Tornillo de cabeza plana	4,5x45 mm	<b>04</b>					
<b>N</b>		<b>Garra de metal</b> Metal claw Garra metal	-	<b>10</b>					
<b>O</b>		<b>Parafuso flangeado</b> Flanged head screw Tornillo de cabeza flangeada	3,5x25 mm	<b>06</b>					

IDENTIFICAÇÃO DAS PEÇAS/ PARTS IDENTIFICATION/ IDENTIFICACIÓN DE LAS PIEZAS

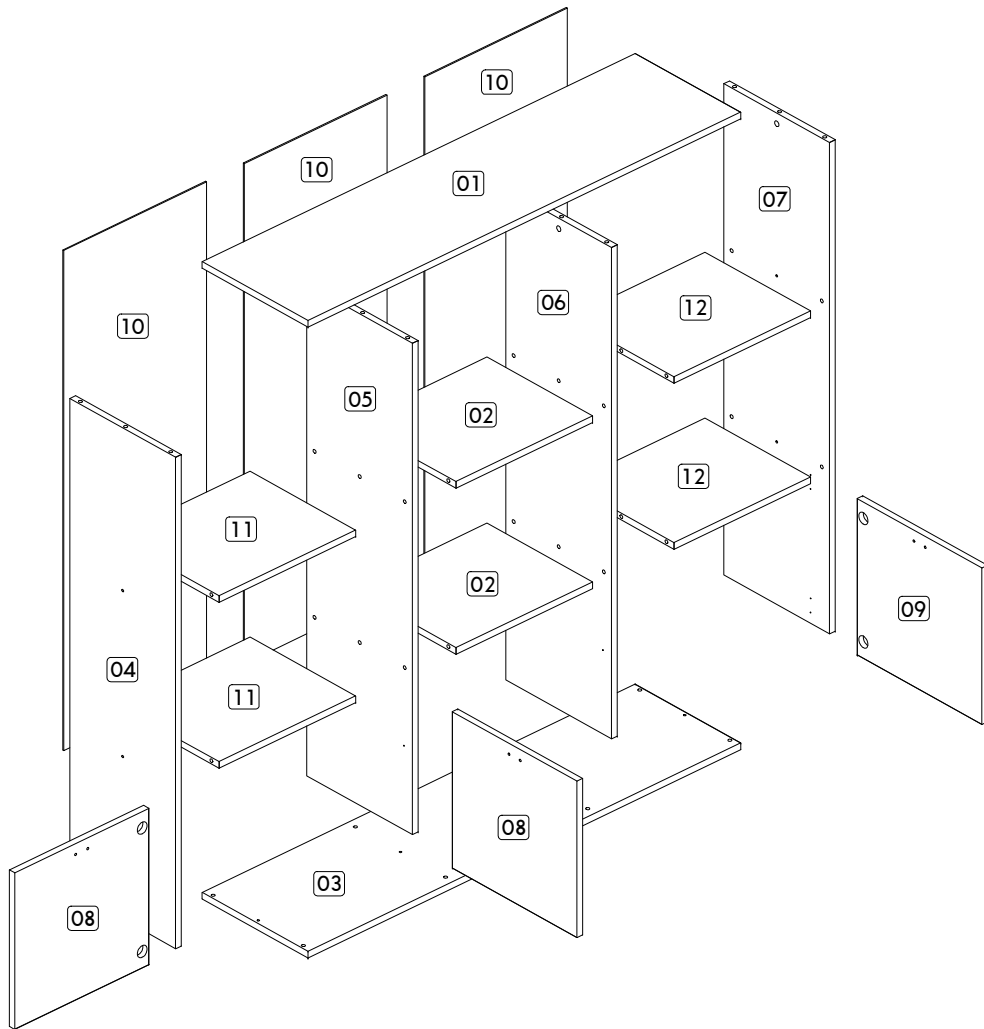

Nº	DESCRIÇÃO - DESCRIPTION - DESCRIPCIÓN	MEDIDAS-MEASURES - MEDIDAS (mm)	QTD.
01	Base superior - Top base - Base superior	1142 x 300 x 15	01
02	Prateleira central - Center shelf - Repisa central	360 x 300 x 15	02
03	Base inferior - Bottom base - Base inferior	1142 x 300 x 15	01
04	Lateral esquerda - Left side - Lateral izquierda	1110 x 300 x 15	01
05	Divisão esquerda - Left division - División izquierda	1110 x 300 x 15	01
06	Divisão direita - Right division - División derecha	1110 x 300 x 15	01
07	Lateral direita - Right side - Lateral derecha	1110 x 300 x 15	01
08	Porta esquerda/central - Left/center door - Puerta izquierda/central	354 x 354 x 15	02
09	Porta direita - Right door - Puerta derecha	354 x 354 x 15	01
10	Costa - Back - Fondo	1130 x 376 x 03	03
11	Prateleira esquerda - Left shelf - Repisa izquierda	360 x 300 x 15	02
12	Prateleira direita - Right shelf - Repisa derecha	360 x 300 x 15	02

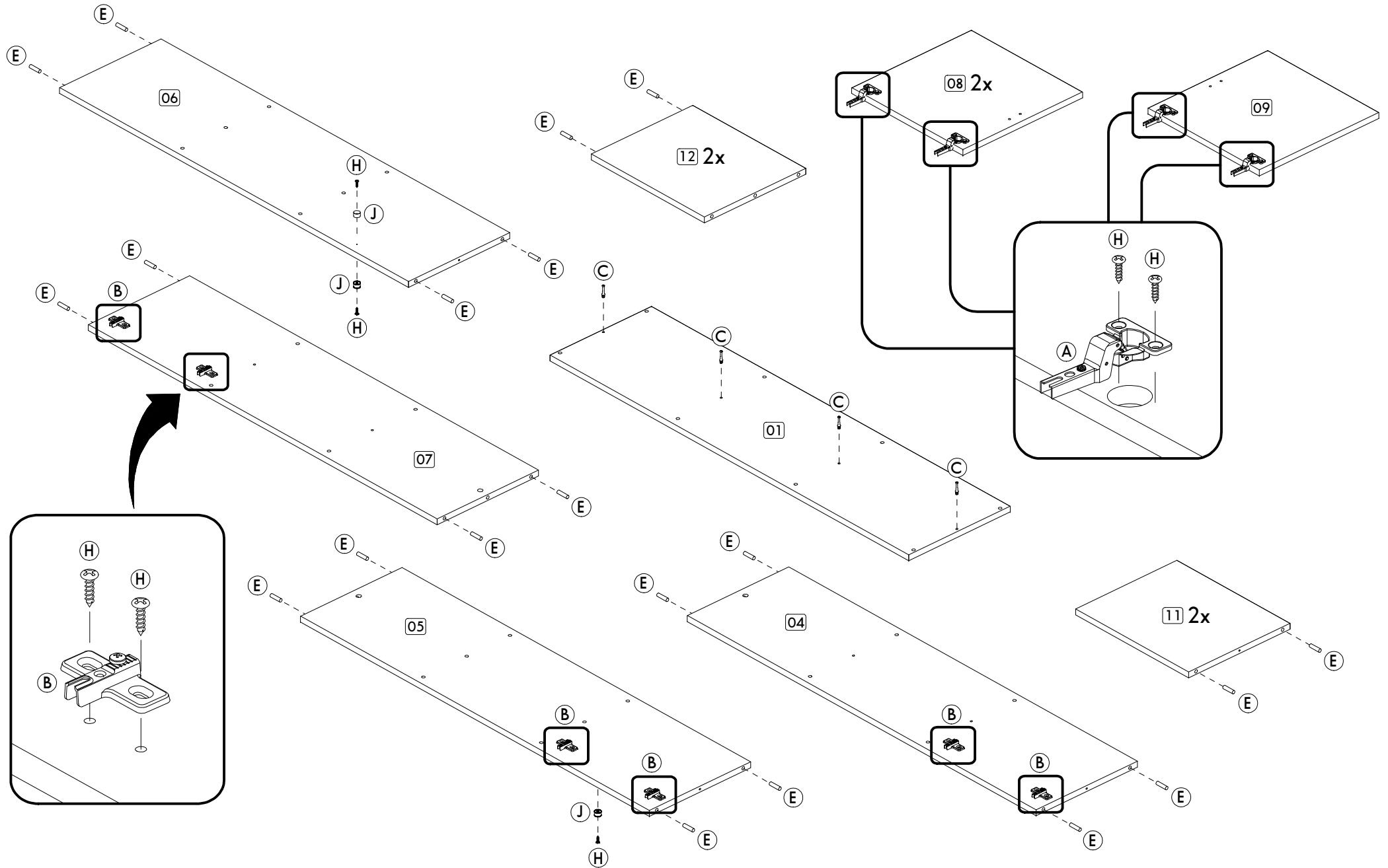

Passo/ Step/ Paso 01

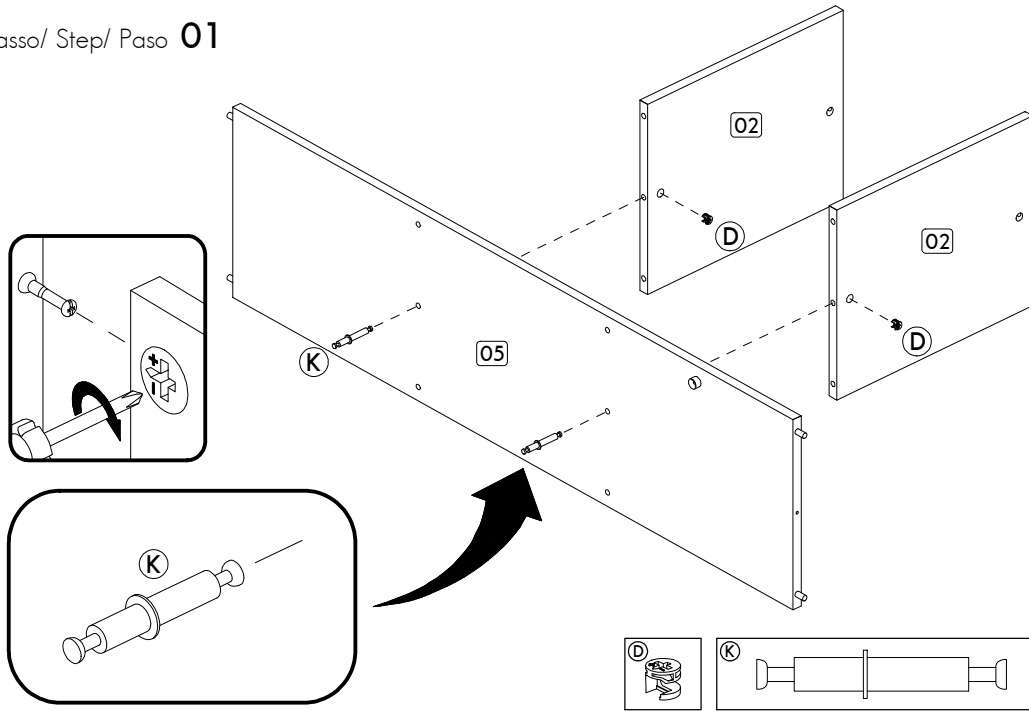

Passo/ Step/ Paso 02

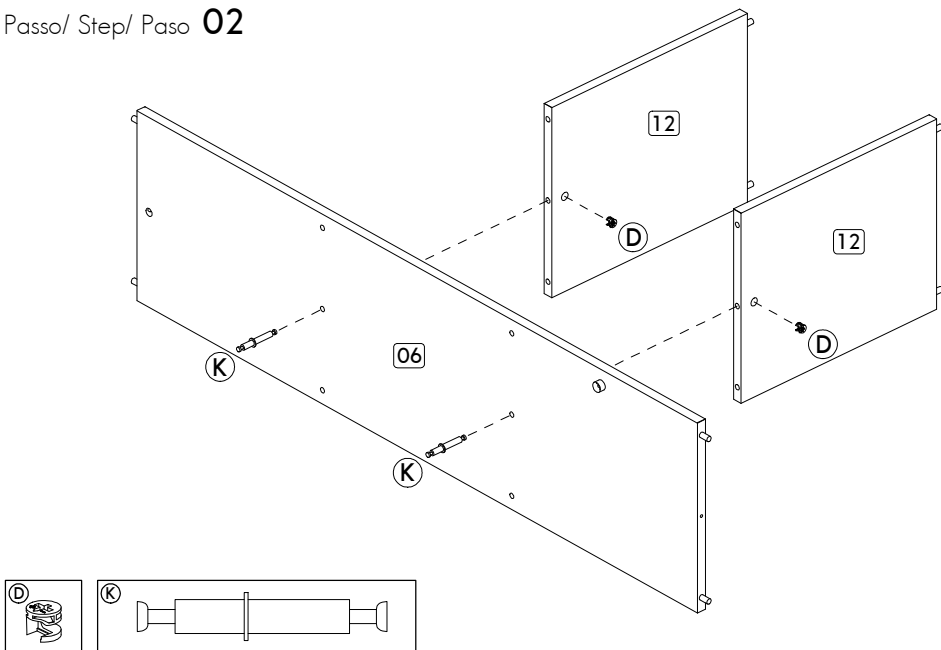

Passo/ Step/ Paso 03

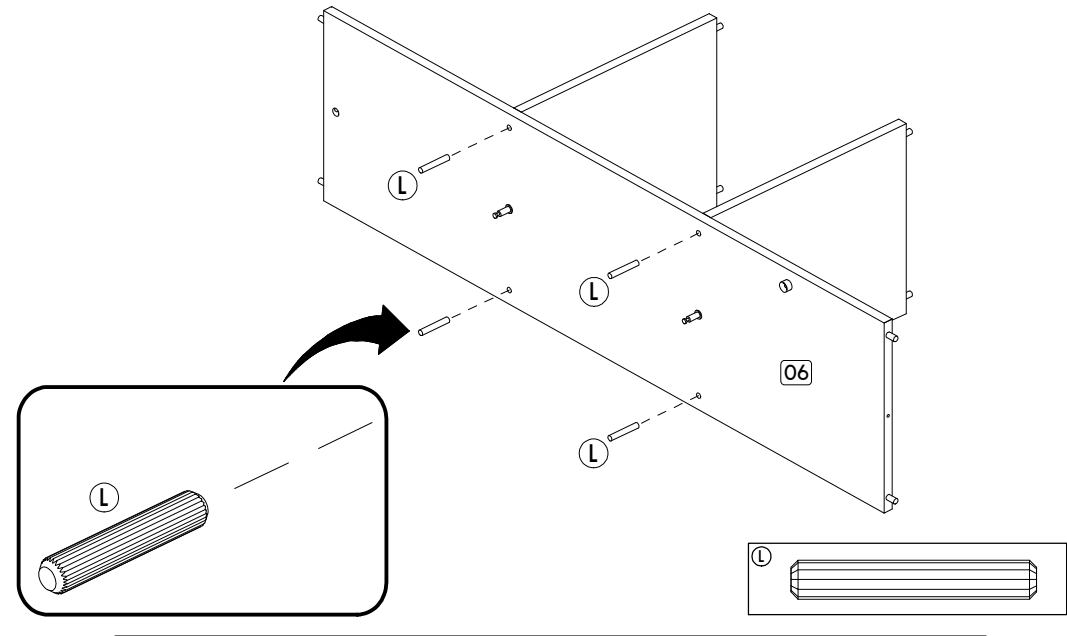

Passo/ Step/ Paso 04

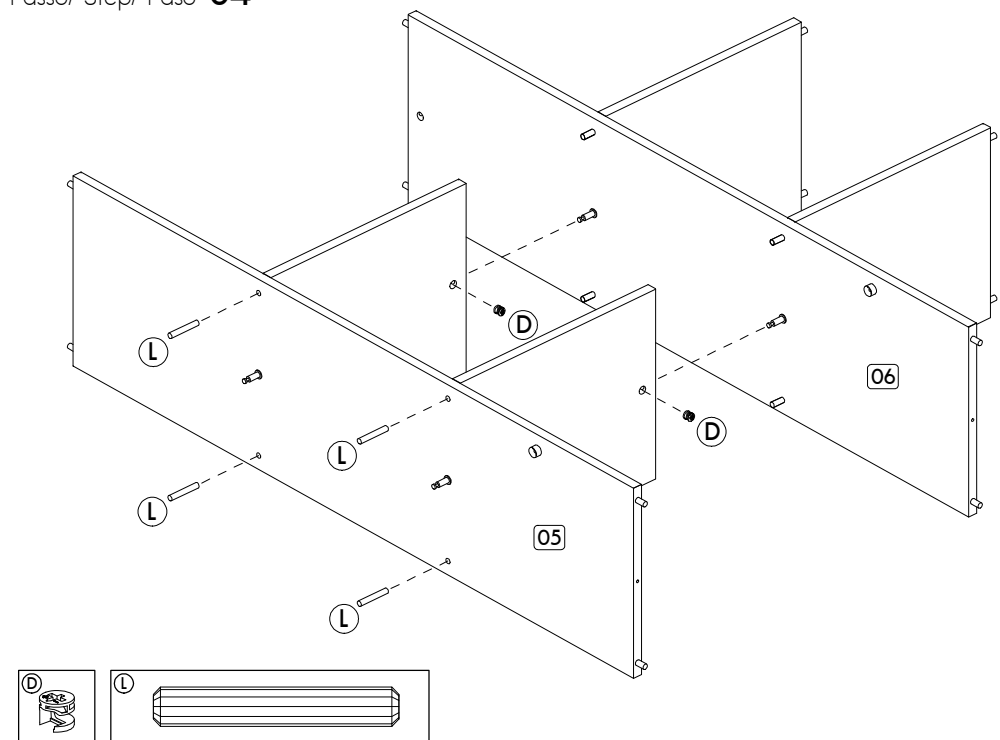

Passo/ Step/ Paso 05

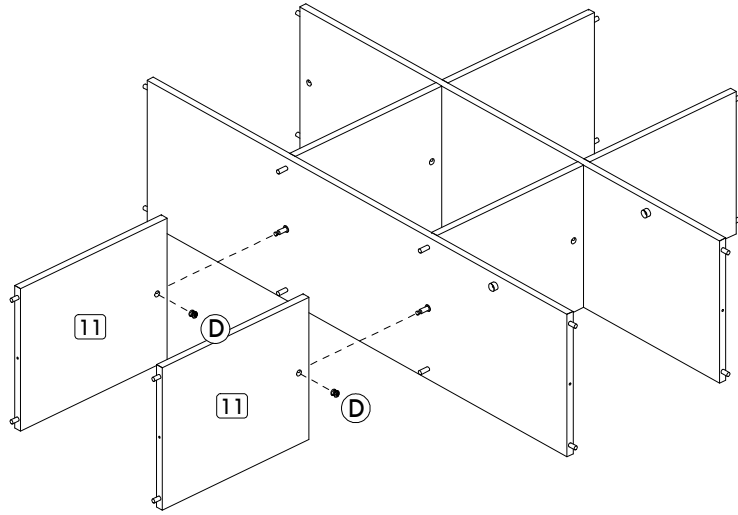

Passo/ Step/ Paso 06

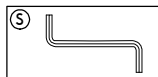
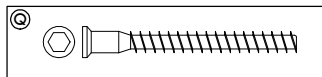
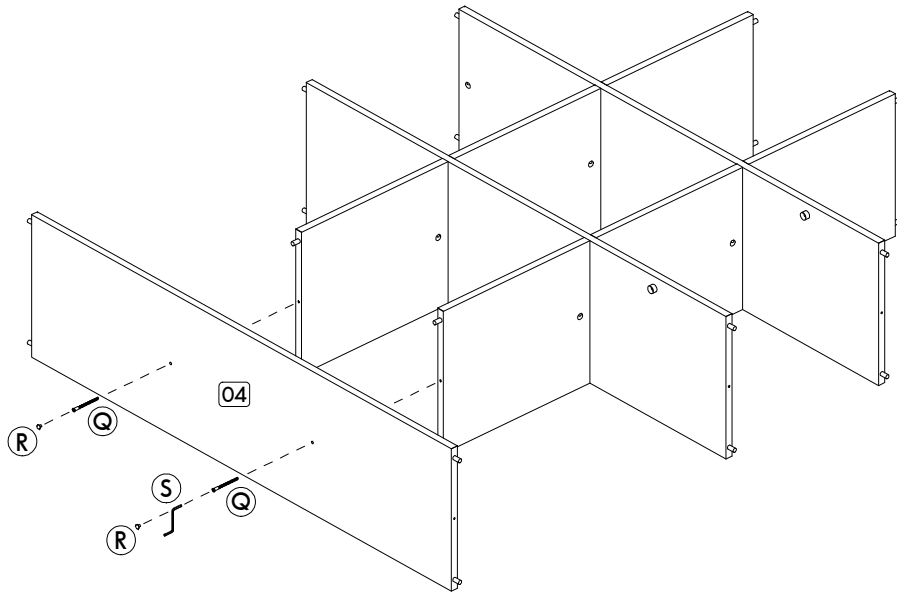

Passo/ Step/ Paso 07

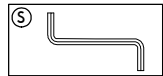
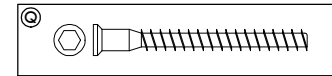
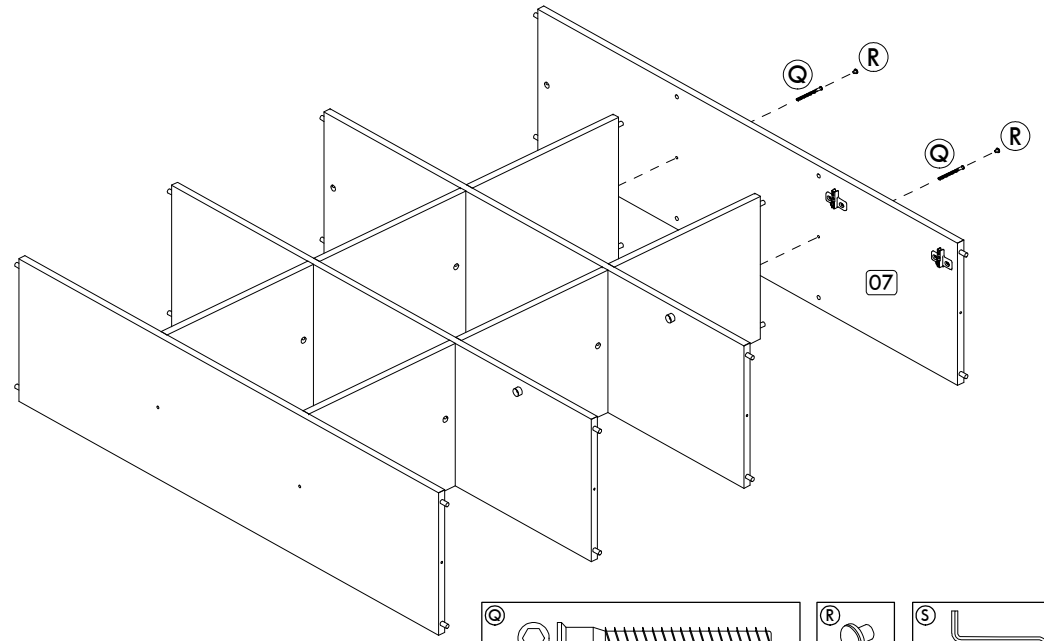

Passo/ Step/ Paso 08

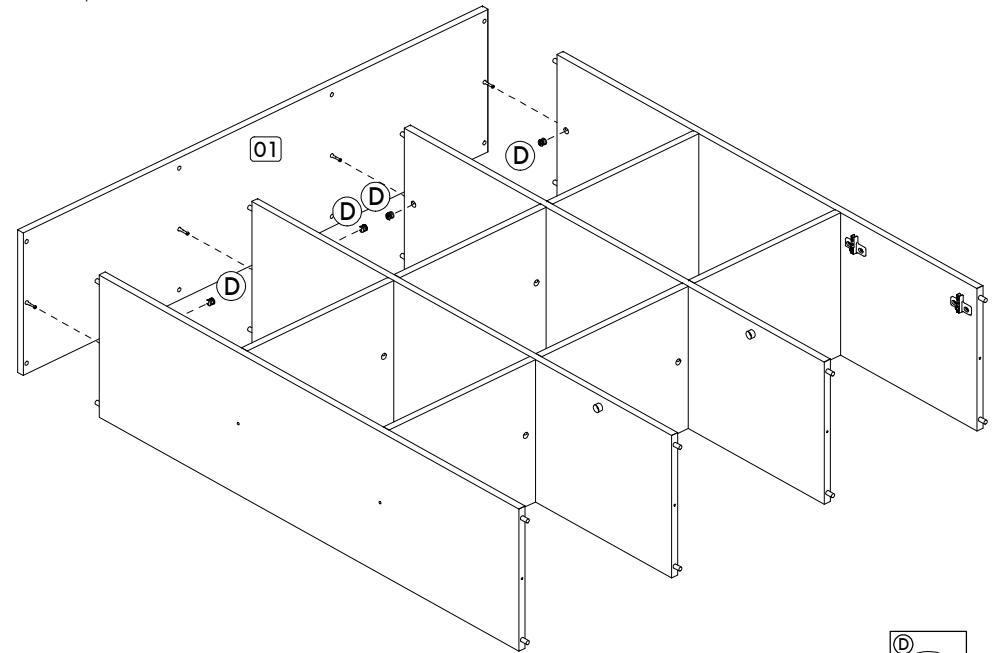

Passo/ Step/ Paso 05

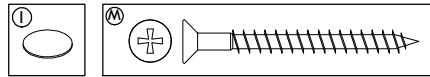
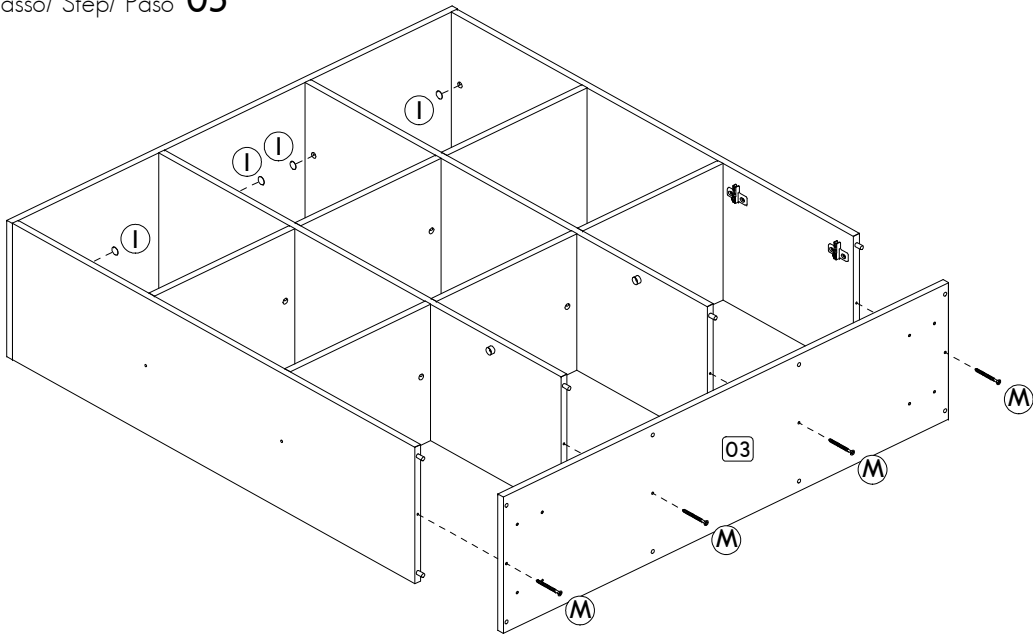

Siga os passos a seguir para fixação das sapatas!  
 Follow the steps below to fix the feet!  
 Siga los siguientes pasos para fijar las patas!

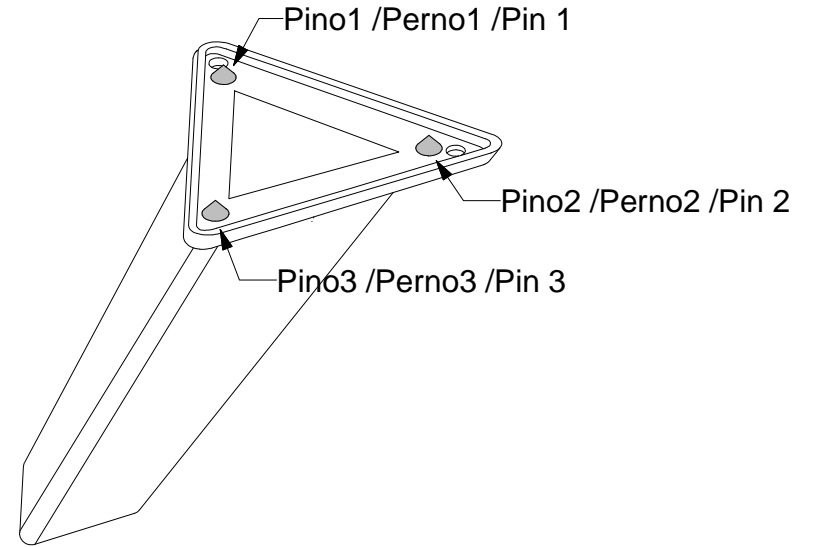

Passo/ Step/ Paso 06

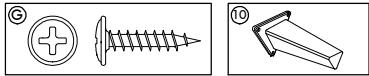
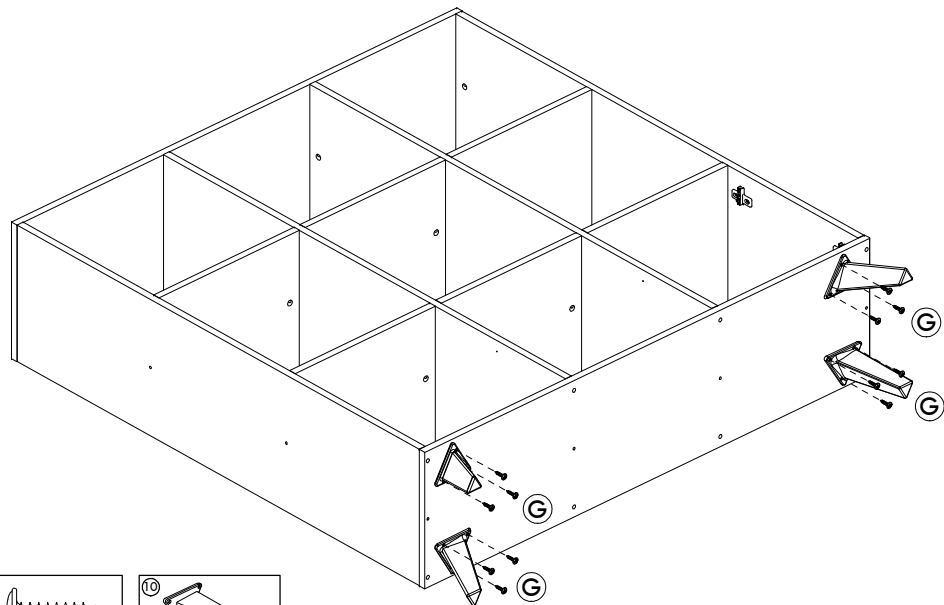

**IMPORTANT!**  
 Os pés devem ser fixados manualmente, sem utilização da parafusadeira.  
**IMPORTANT!**  
 The feet must be set manually, without using the screwdriver.  
**IMPORTANT!**  
 Los pies se deben ajustar manualmente, sin utilizar el destornillador

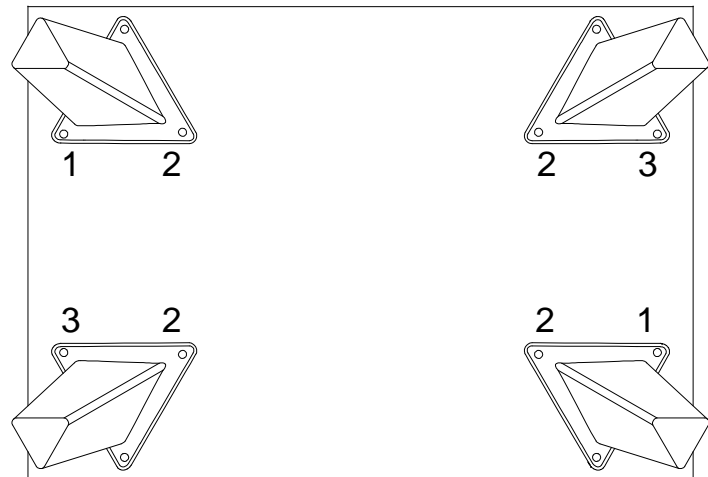
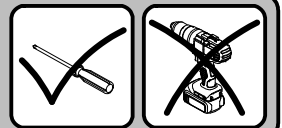

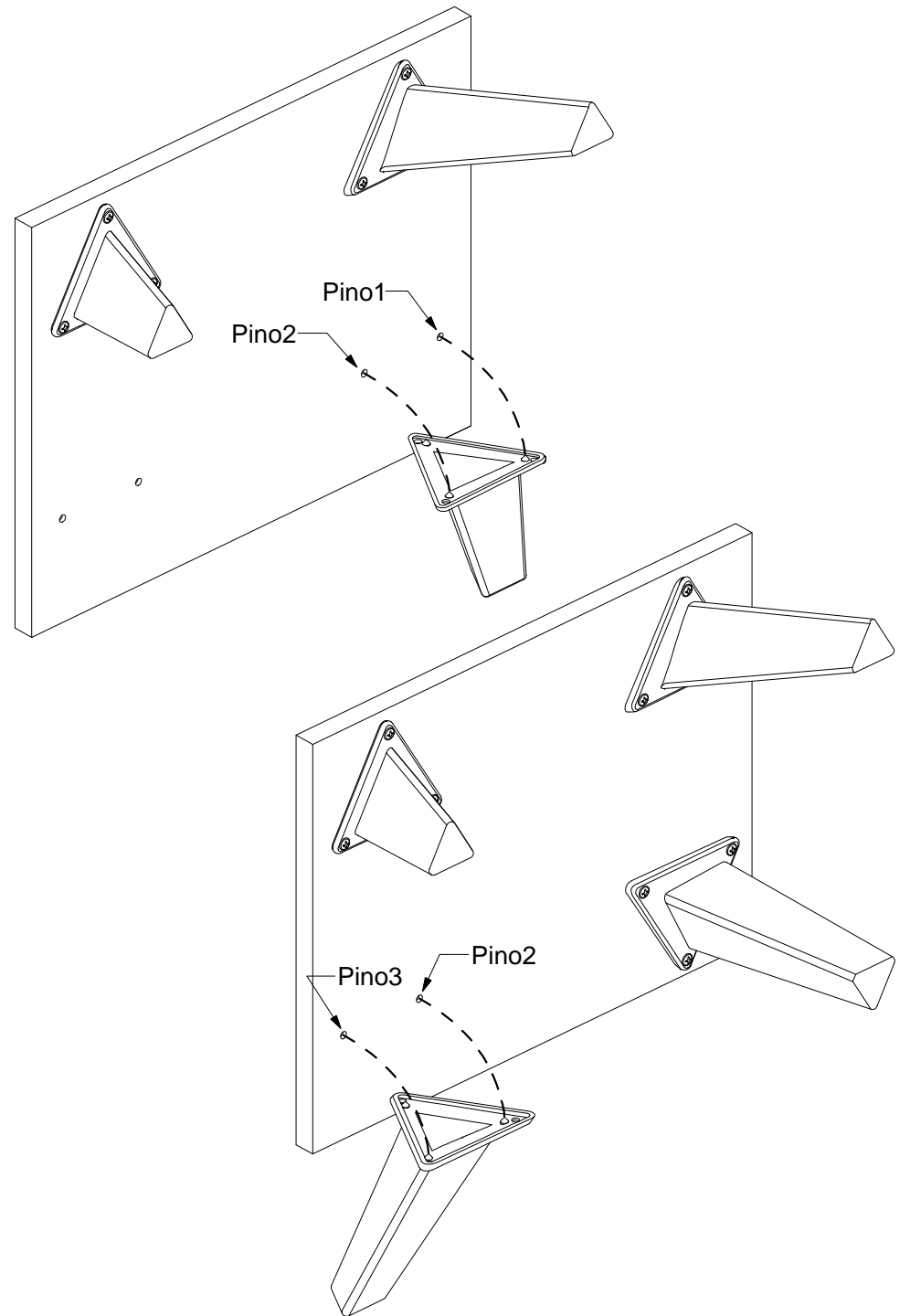
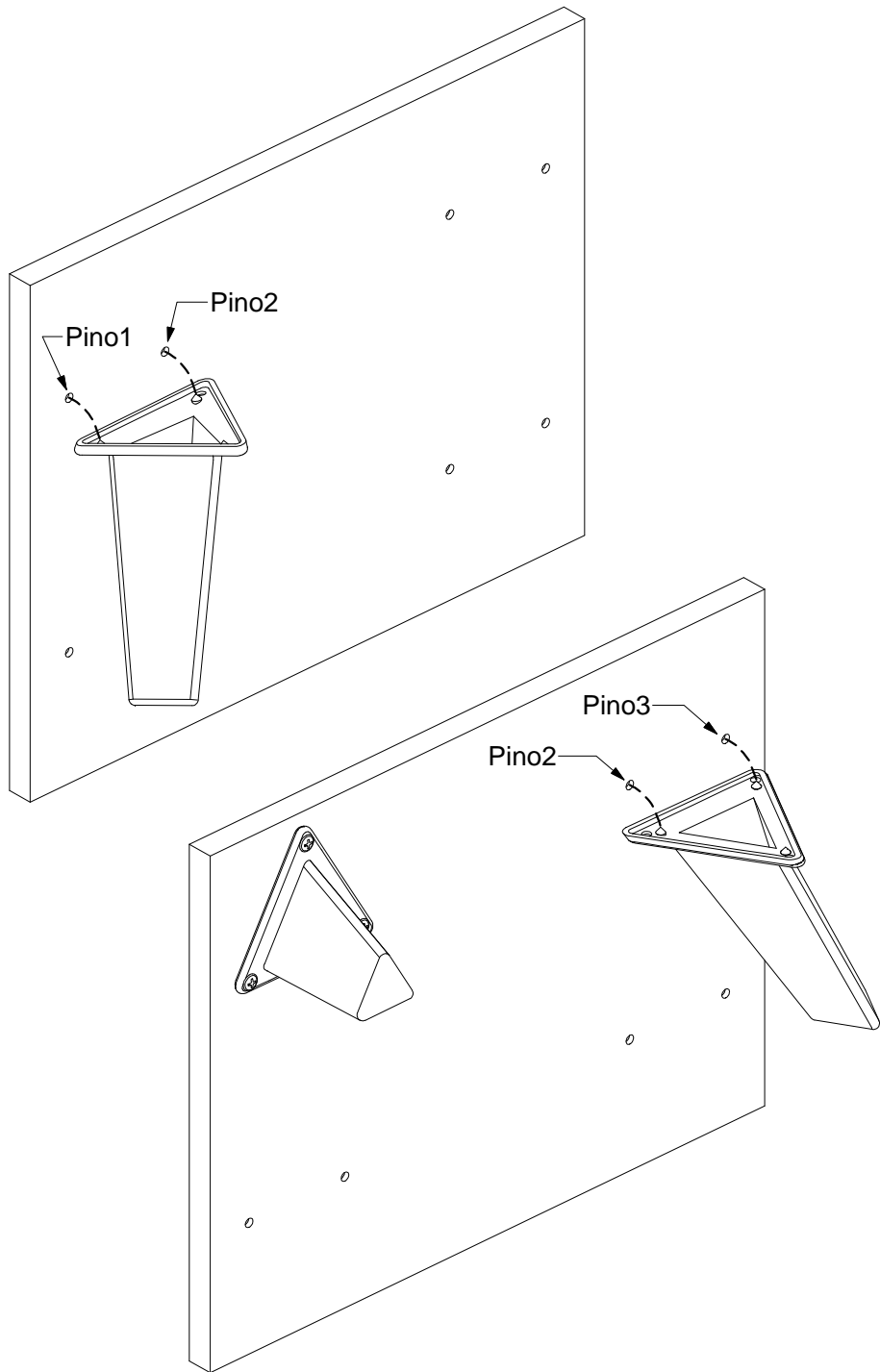



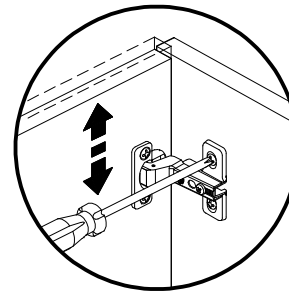
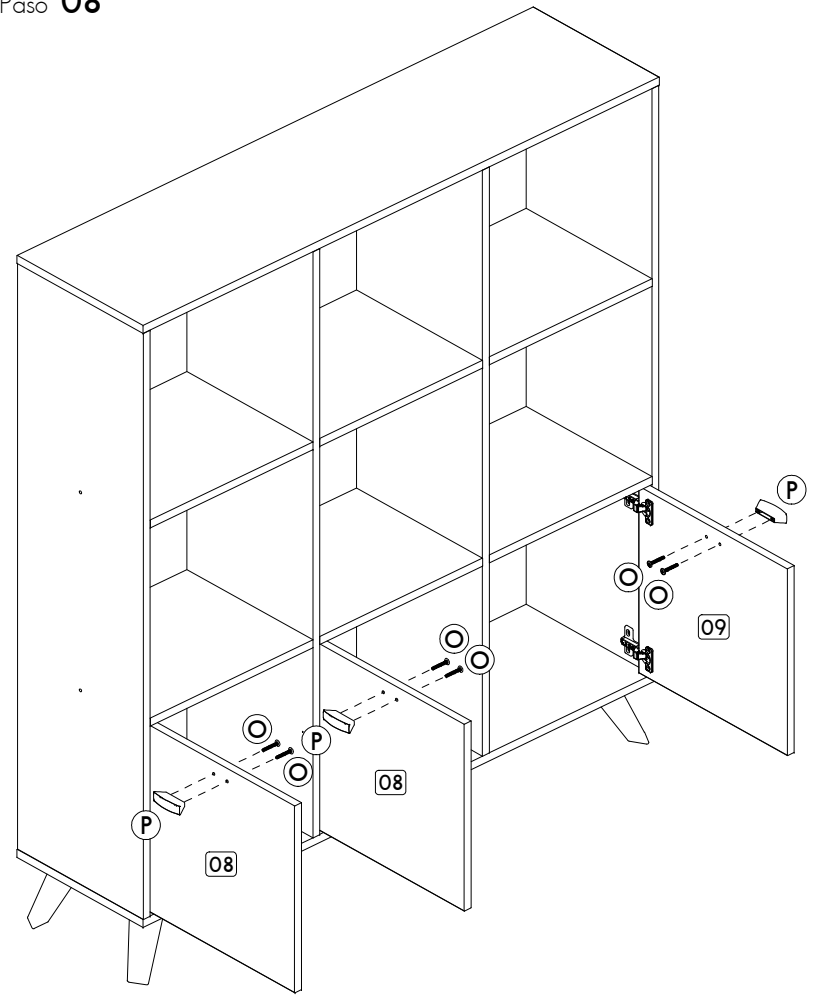
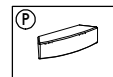
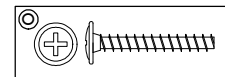
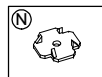
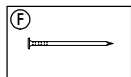
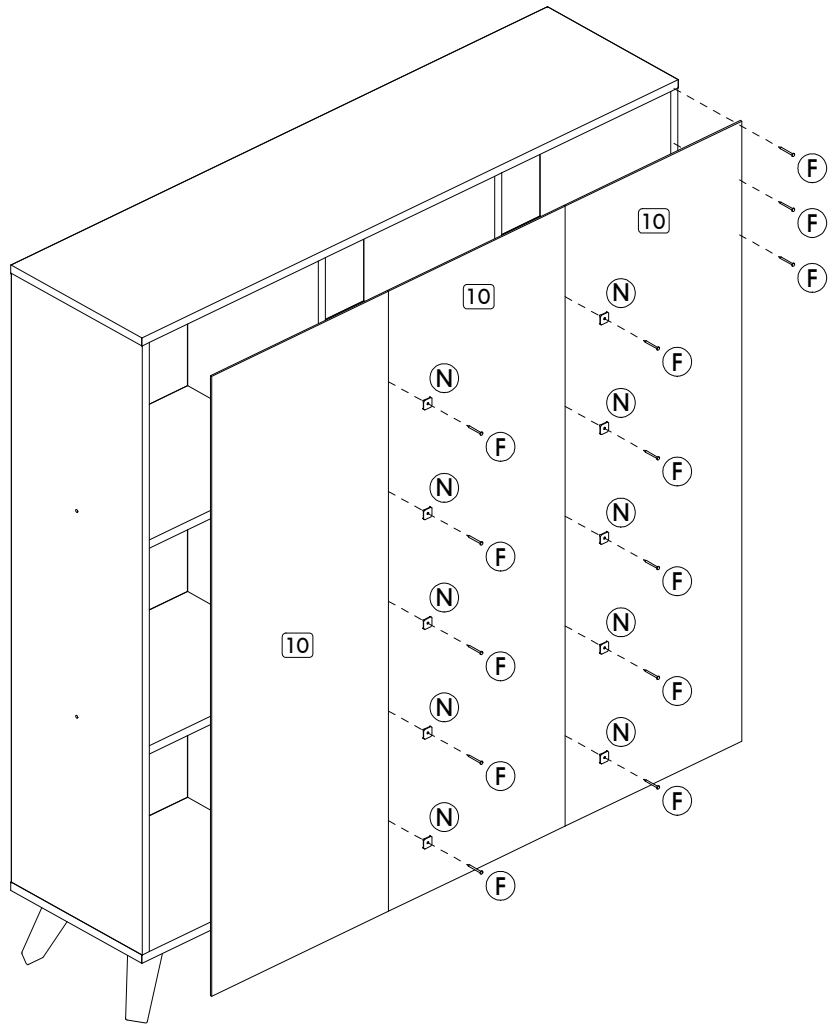

Regulagem Vertical  
Ajuste Vertical  
Vertical Adjustment

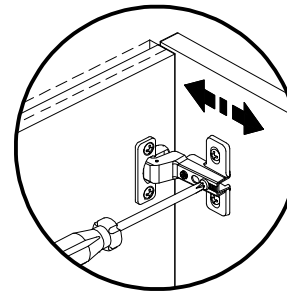

Regulagem Profundidade  
Ajuste Profundidad  
Depth Adjustment

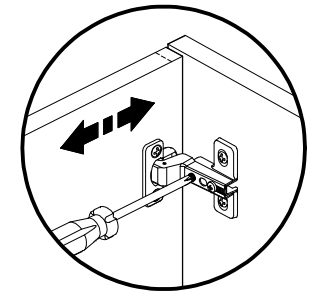

Regulagem Horizontal  
Ajuste Horizontal  
Horizontal Adjustment