

MANUAL DE MONTAGEM
Assembly instructions / Instrucciones de armado

MESA FÊNIX - 3 GAVETAS

Office table Fênix - 3 drawers
Escritorio Fênix - 3 cajones

Código 1184 | Revisão 02

NOTA: Este produto pode ser montado com as gavetas para a sua direita ou esquerda.

NOTE: This product can be assembled with drawers to right or left.

NOTA: Este producto se puede armar con los cajones a la derecha o izquierda.

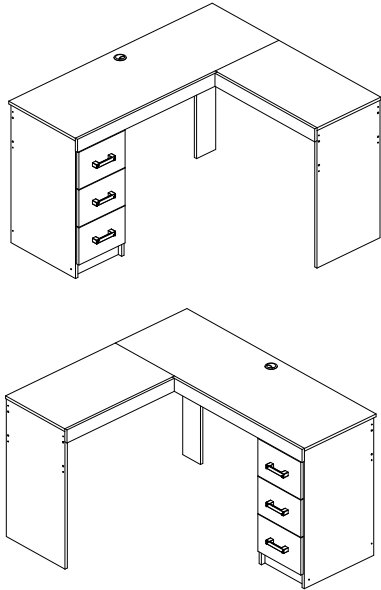

PESO MÁXIMO SUPORTADO PELAS PEÇAS, SENDO ESTE DISTRIBUÍDO UNIFORMEMENTE.

Maximum weight supported by parts, being this evenly distributed.

Peso máximo soportado por las partes, siendo esta distribuido uniformemente.

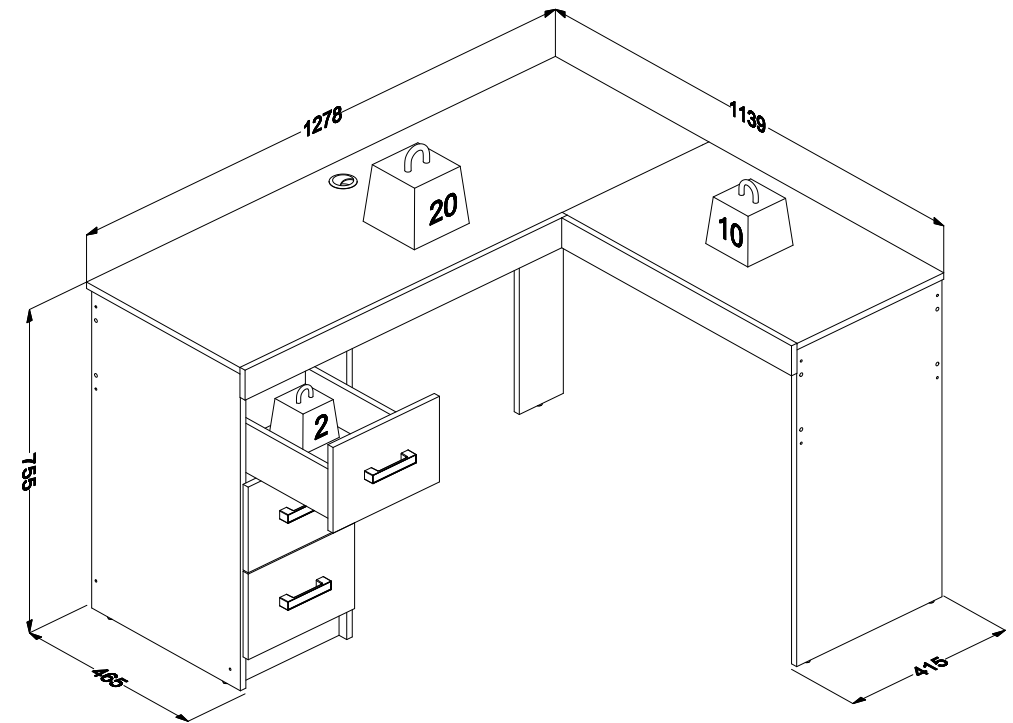

Você vai precisar de/ You will need / Usted necesitará

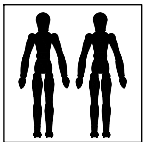

2 Pessoas
2 people
2 personas

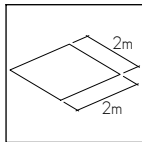

Espaço recomendado para montagem
Recommended space for assemble
Espacio recomendado para el armado

Ferramentas não inclusas
Tools not included / Herramientas no incluidas

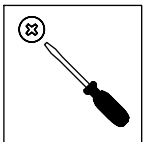

Chave Philips
Screwdriver
Destornillador cruz

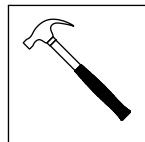

Martelo
Hammer
Martillo











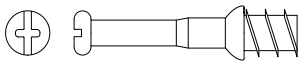

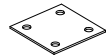

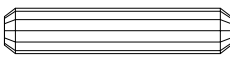

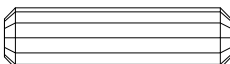

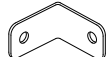
* PESO EM KG/ Weight in Kg/ Peso en Kg
DIMENSÕES EM MM/ Dimensions in mm/ Dimensiones en mm

IDENTIFICAÇÃO DOS ACESSÓRIOS/ IDENTIFICATION OF ACCESSORIES/ IDENTIFICACIÓN DE ACCESORIOS

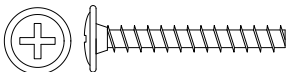
NOTAS: A separação dos acessórios antes de iniciar a montagem facilitará a mesma. Os parafusos e cavilhas estão na escala real. Em caso de dúvida na identificação, coloque o acessório sobre a imagem.

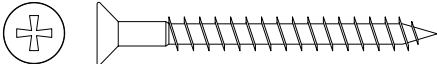
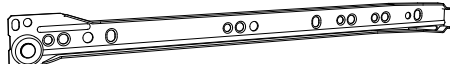
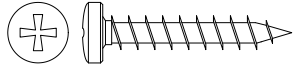
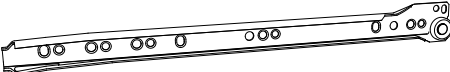
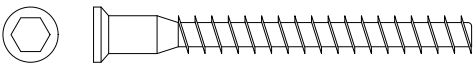
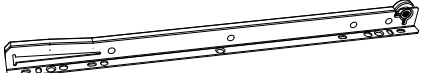
NOTES: The separation of the accessories before you start the assembly will facilitate the same. The screws and dowels are in real scale. In case of doubts about the identification, place the accessory on the image.

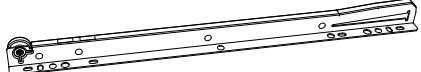
NOTAS: La separación de los accesorios antes de comenzar el armado facilitará el mismo. Los tornillos y taquetes son en escala real. En caso de dudas sobre la identificación, coloque el accesorio en la imagen.

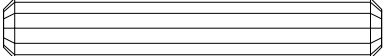
A		Haste minifix simples Simple minifix screw Tornillo minifix simple	-	15	P		Puxador Handle Tirador	96 mm	03
B		Tambor minifix Cam lock Tambor minifix	-	15	Q		Junção de tampos Junction of tops Unión de tapas	-	02
C		Tapa furo adesivo Bore patch adhesive Tapones adhesivo	-	08	R		Passa fios Pass wires Pasar cables	46 mm	01
D		Cavilha Wooden Dowel Pin	6x30 mm	24	S		Tapa furo plástico Tapones plásticos Plastic hole plugs	8 mm	08
E		Cavilha Wooden Dowel Pin	8x30 mm	14	T		Tapa furo plástico Tapones plásticos Plastic hole plugs	5 mm	05
F		Cola Glue Pegamento	-	01	U		Cantoneira de metal Metal bracket Soporte de metal	22x22 mm	03
G		Parafuso chato Flat head screw Tornillo de cabeza plana	3,0x14 mm	24	V		Tampa parafuso estrutural Structural screw cover Tapa tornillo estrutural	-	08
H		Parafuso panela Pan head screw Tornillo de pan	3,5x14 mm	32	W		Chave allen Allen key Llave Allen	-	01
I		Parafuso flangeado Flanged head screw Tornillo de cabeza flangeada	3,5x25 mm	06	Y		Cantoneira de metal Metal bracket Soporte de metal	46 mm	03
J		Parafuso chato Flat head screw Tornillo de cabeça plana	4,5x45 mm	06	18A		Corrediça lateral esquerda Metallic slide the left field Corredera lateral izquierda	350 mm	03
K		Parafuso panela Pan head screw Tornillo de pan	4,5x25 mm	02	18B		Corrediça lateral direita Metallic slide the right field Corredera lateral derecha	350 mm	03
L		Parafuso estrutural Structural screw Tornillo estructural	5,0x50 mm	10	18C		Corrediça gaveta esquerda Drawer slide left Corredera izquierda cajón	350 mm	03
M		Prego Nail Clavo	10 x10	07	18D		Corrediça gaveta direita Drawer slide right Corredera derecha cajón	350 mm	03
N		Sapata Small Plastic Foot Pie Plástico	14 mm	07	19		Suporte fixação vistas Fixing bracket of frames Soporte de fijación marcos	-	03
O		Cavilha Wooden Dowel Pin	8x50 mm	01					

IDENTIFICAÇÃO DAS PEÇAS/ PARTS IDENTIFICATION/ IDENTIFICACIÓN DE LAS PIEZAS

NOTA: Vista para montagem das gavetas para sua ESQUERDA

NOTE: View of assembly of drawers to your LEFT

NOTA: Vista de conjunto de cajones a tu IZQUIERDA

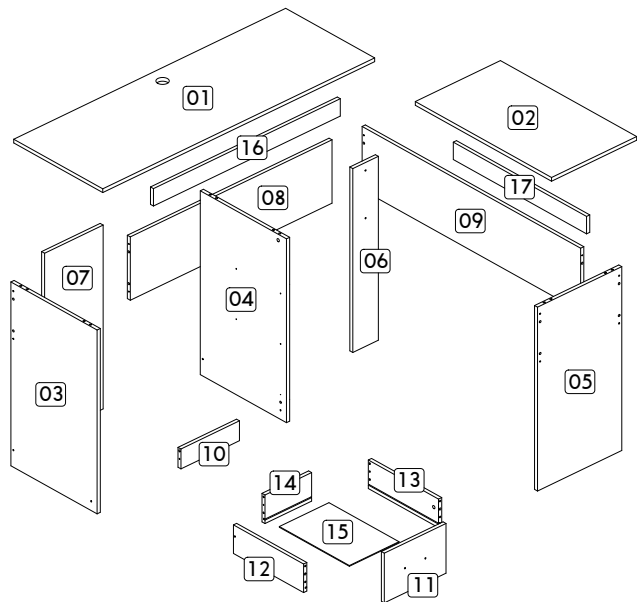

NOTA: Vista para montagem das gavetas para sua DIREITA

NOTE: View of assembly of drawers to your RIGHT

NOTA: Vista de conjunto de cajones a tu DERECHA

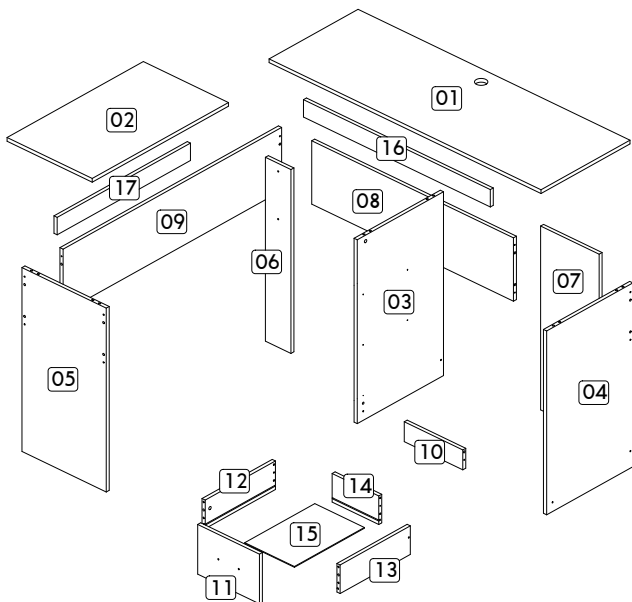

Nº	DESCRIÇÃO - DESCRIPTION - DESCRIPCIÓN	MEDIDAS-MEASURES - MEDIDAS (mm)	QTD.
01	Base superior maior - Bigger top base - Base superior mayor	1278 x 450 x 15	01
02	Base superior menor - Smaller top base - Base superior menor	689 x 400 x 15	01
03	Lateral esquerda - Left lateral - Lateral izquierda	740 x 436 x 15	01
04	Divisão gavetas - Drawer division - División cajones	740 x 436 x 15	01
05	Lateral direita - Right side - Lateral derecha	740 x 396 x 15	01
06	Pé - Foot - Pie	740 x 120 x 15	01
07	Costa gaveteiro - Back module drawers - Fondo módulo cajones	740 x 275 x 15	01
08	Costa menor - Smaller back - Fondo menor	948 x 255 x 15	01
09	Costa maior - Bigger back - Fondo mayor	1105 x 255 x 15	01
10	Rodapé - Footer - Rodapie	275 x 80 x 15	01
11	Frente de gaveta - Drawer front - Frente del cajón	290 x 200 x 15	03
12	Lateral esquerda de gaveta - Left side of drawer - Lateral izquierda del cajón	355 x 115 x 15	03
13	Lateral direita de gaveta - Right side of drawer - Lateral derecha del cajón	355 x 115 x 15	03
14	Traseiro de gaveta - Rear of drawer - Trasero del cajón	219 x 115 x 15	03
15	Fundo de gaveta - Bottom of drawer - Fondo del cajón	354 x 233 x 03	03
16	Vista maior - Bigger frame - Moldura mayor	878 x 70 x 15	01
17	Vista menor - Smaller frame - Moldura menor	674 x 70 x 15	01

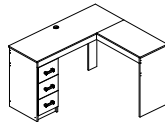

NOTA: Se optou por montar as gavetas para a direita, vá para a página 7
NOTE: If you chose to install the drawers to the right, go to page 7
NOTA: Si elegiste instalar los cajones a la derecha, ir a la página 7

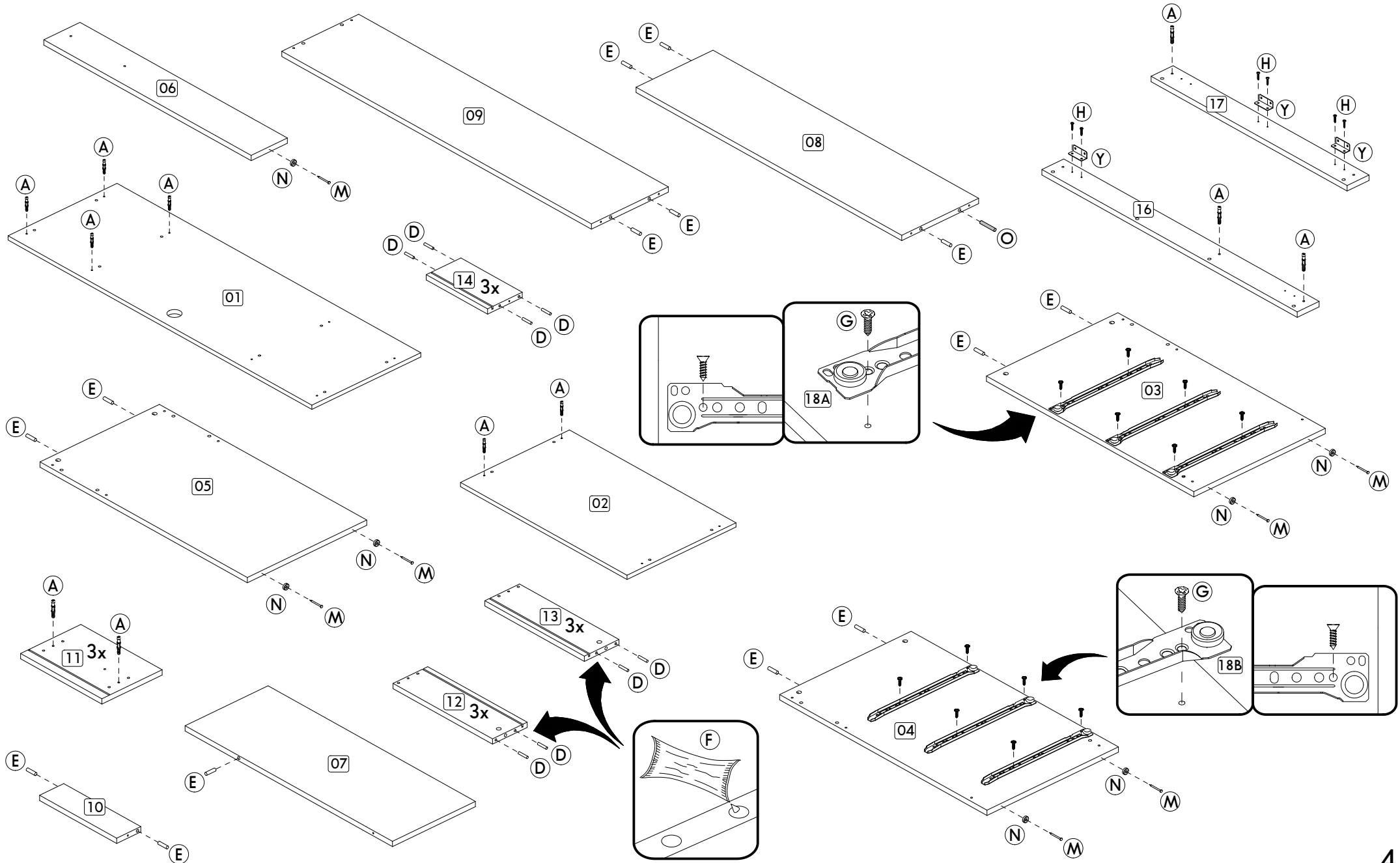

Passo/ Step/ Paso 01

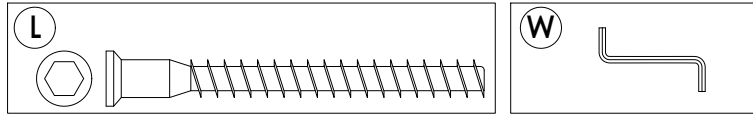
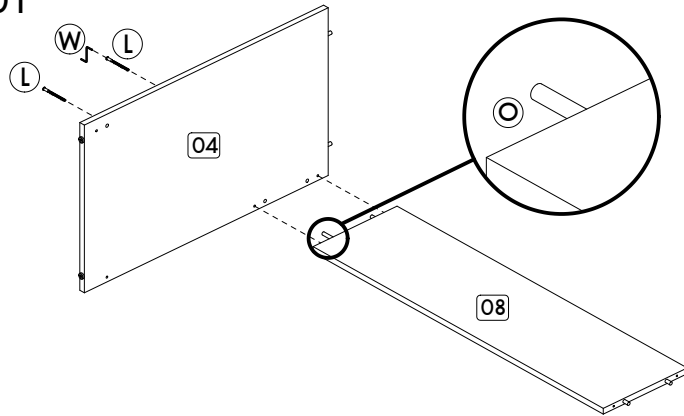

Passo/ Step/ Paso 02

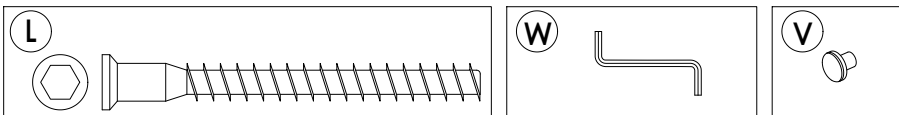
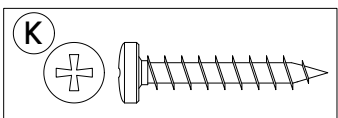
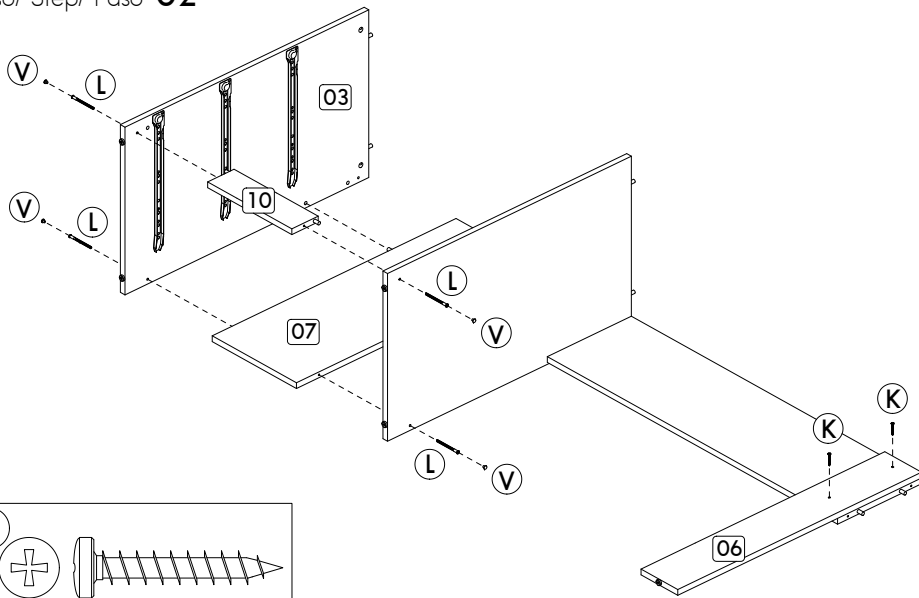

Passo/ Step/ Paso 03

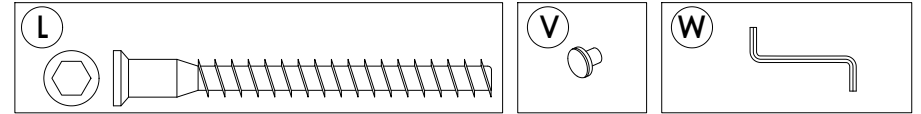
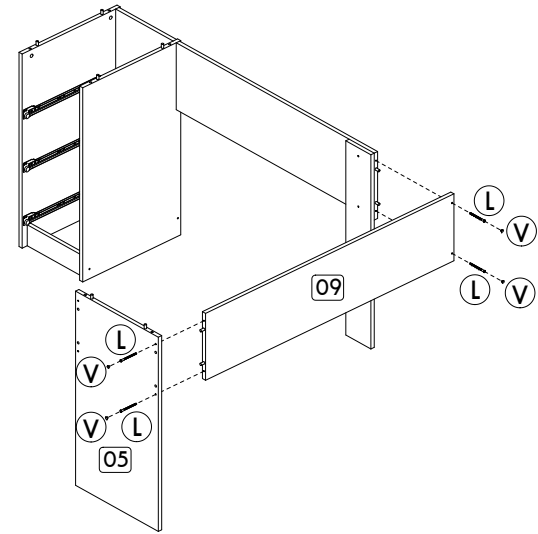

Passo/ Step/ Paso 04

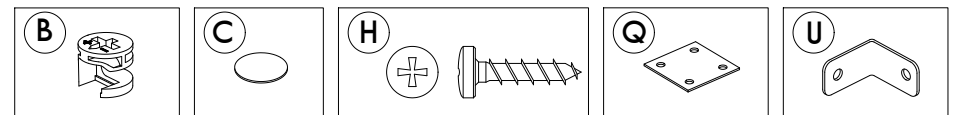
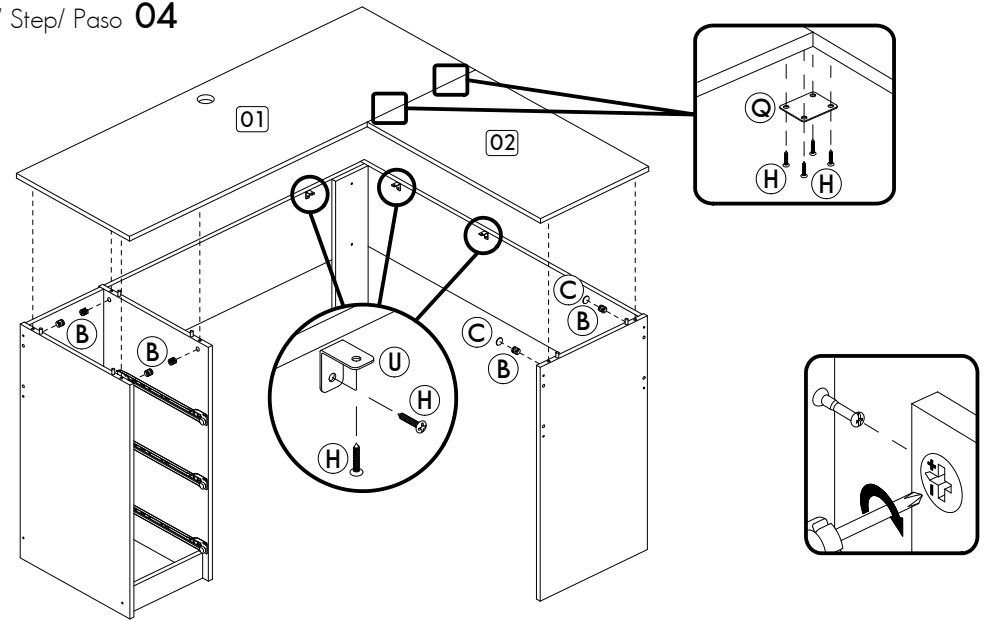

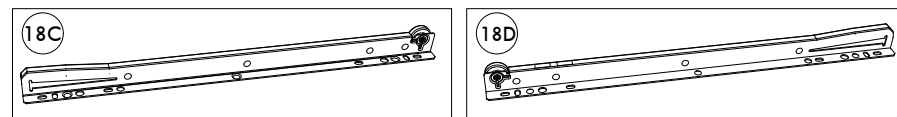
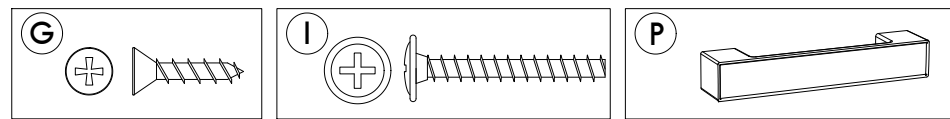
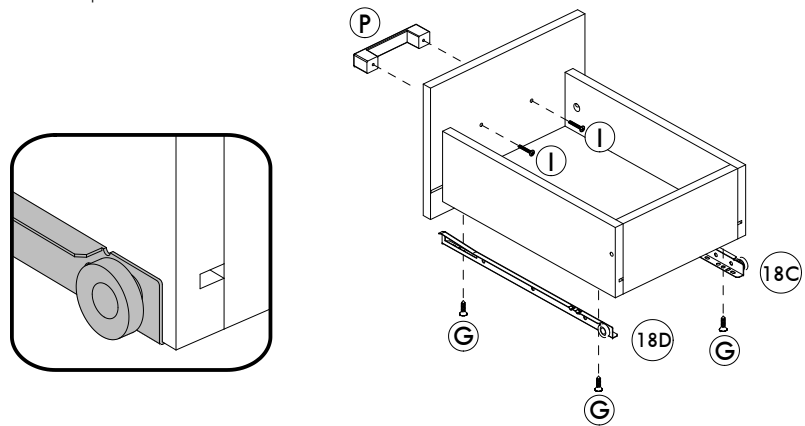
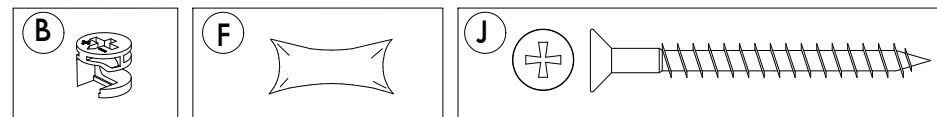
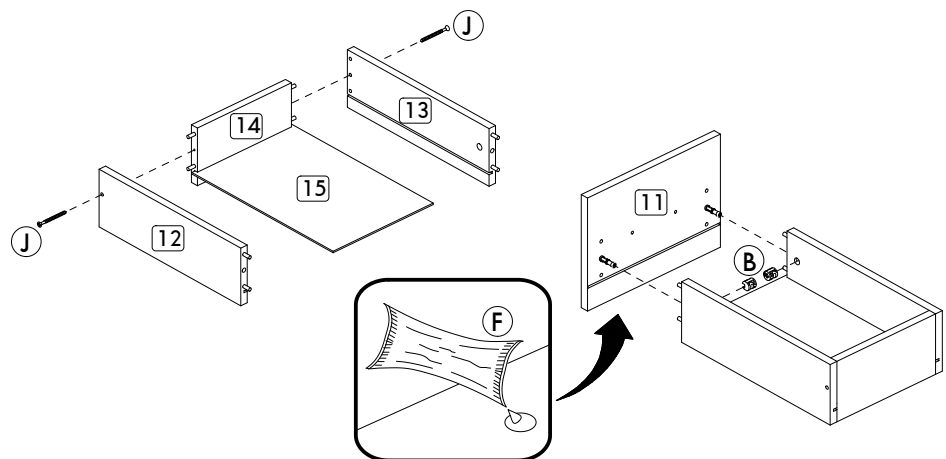
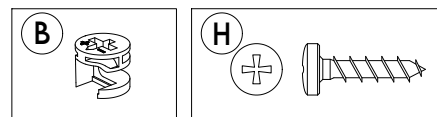
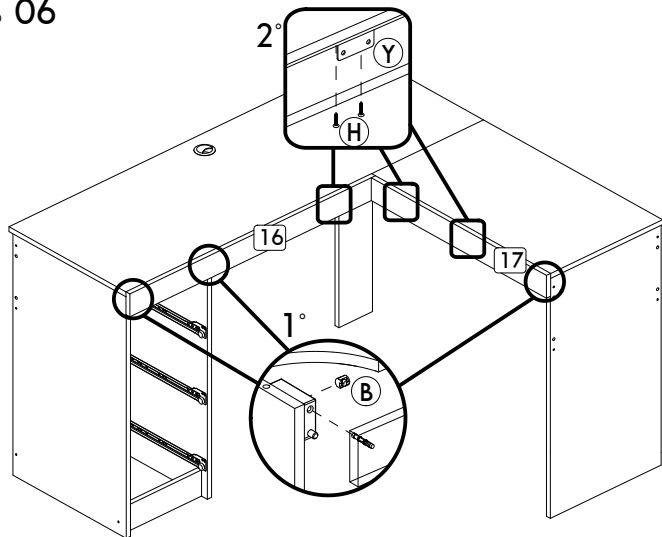
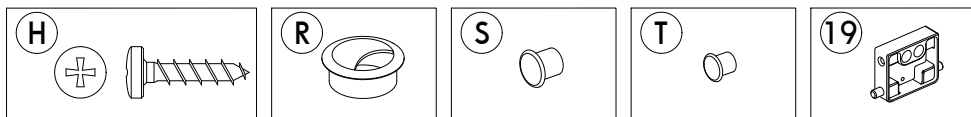
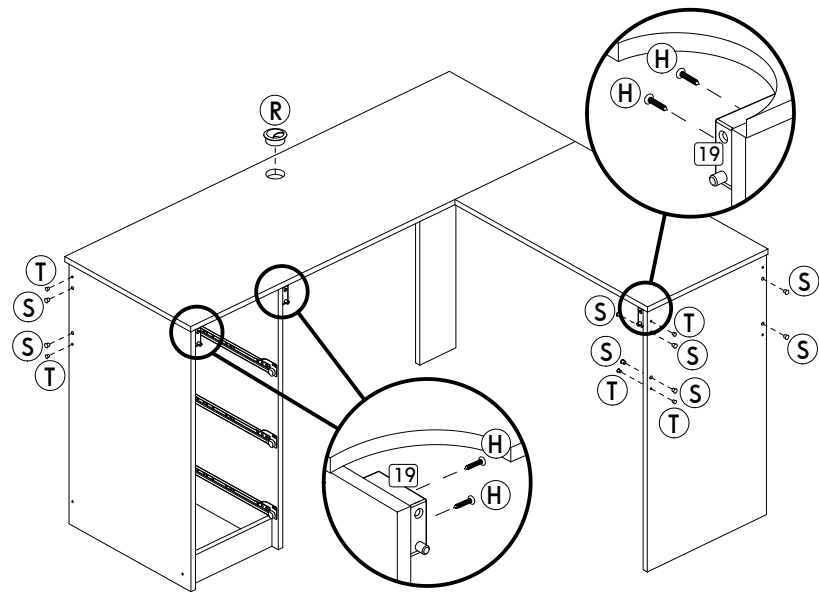

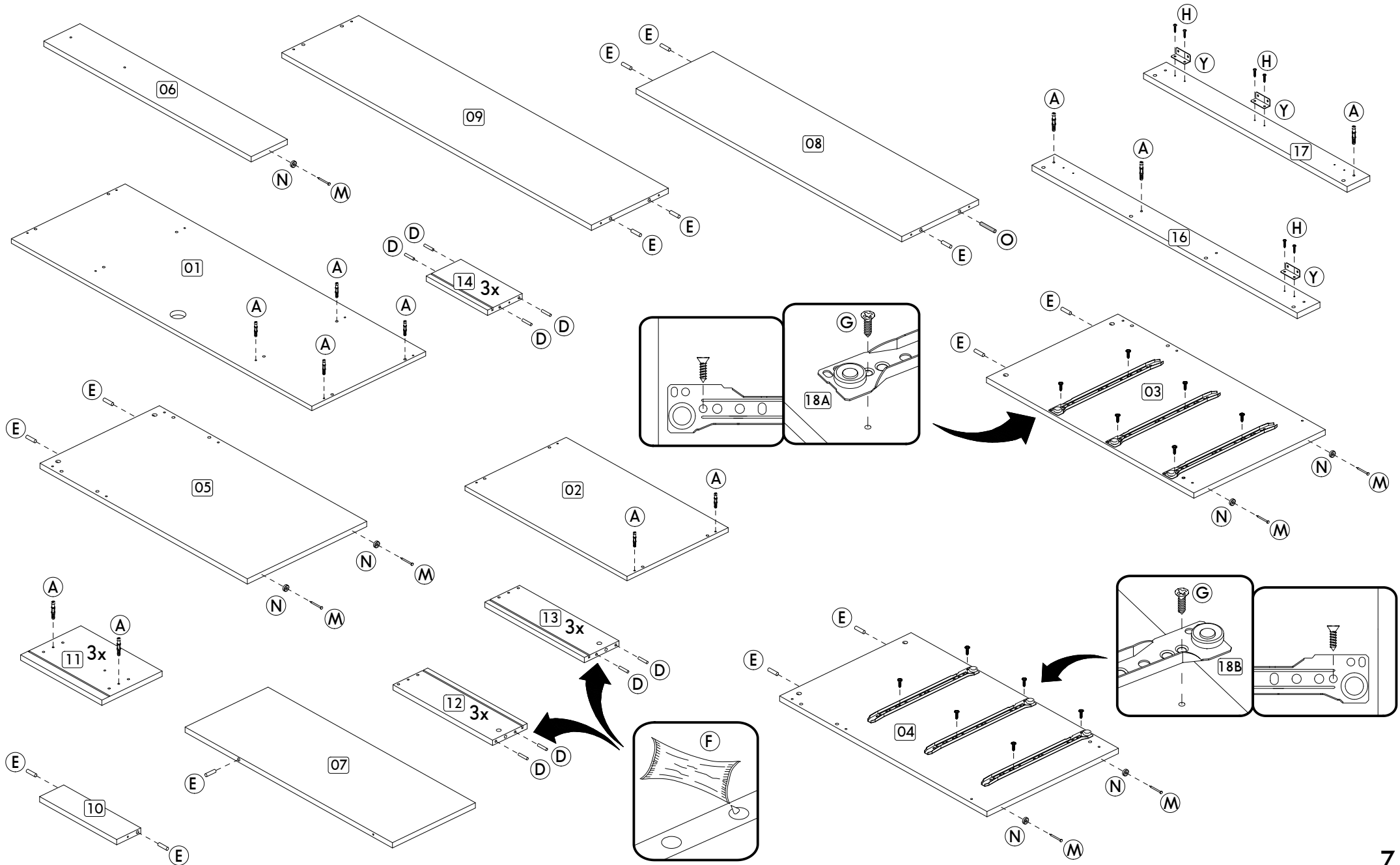
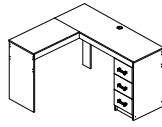

Passo/ Step/ Paso 01

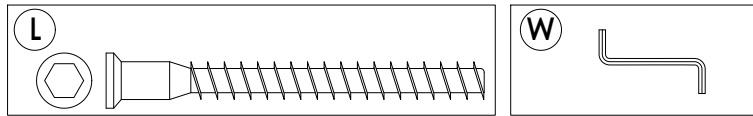
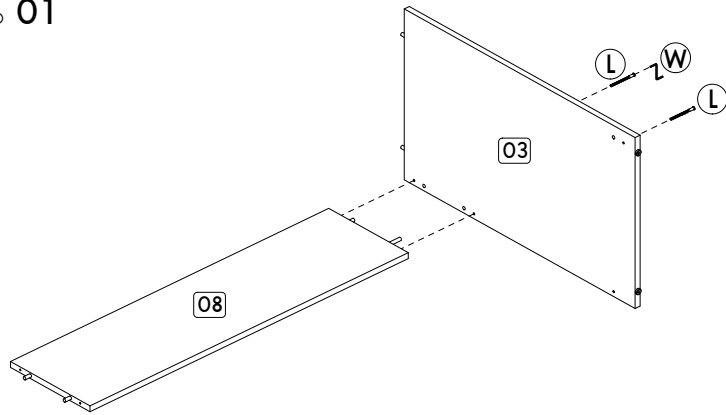

Passo/ Step/ Paso 02

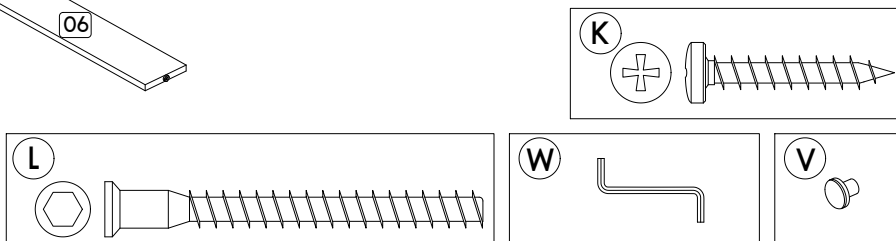
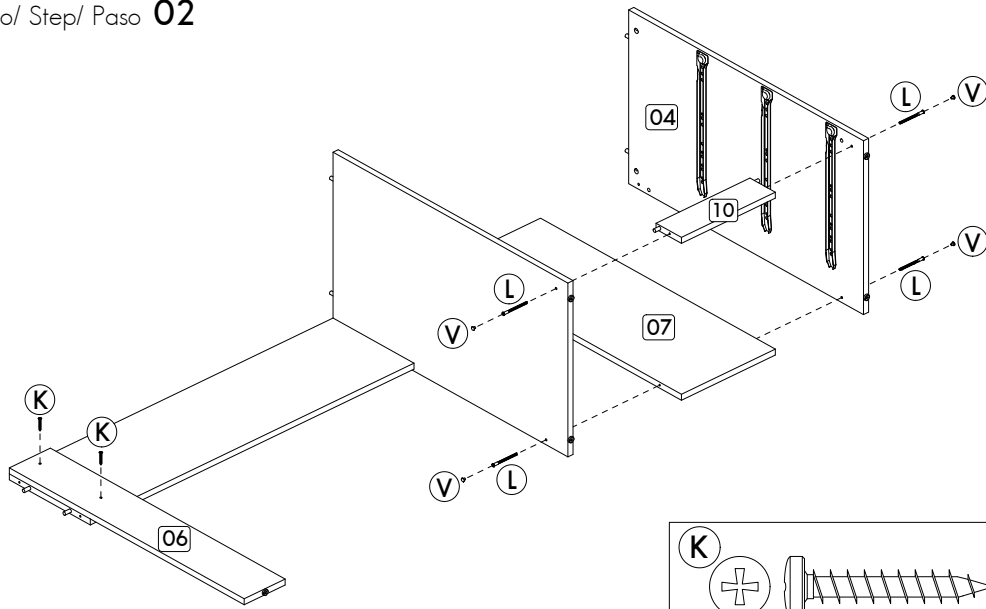

Passo/ Step/ Paso 03

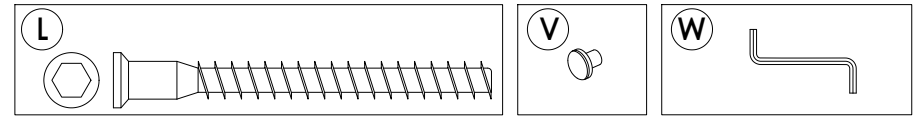
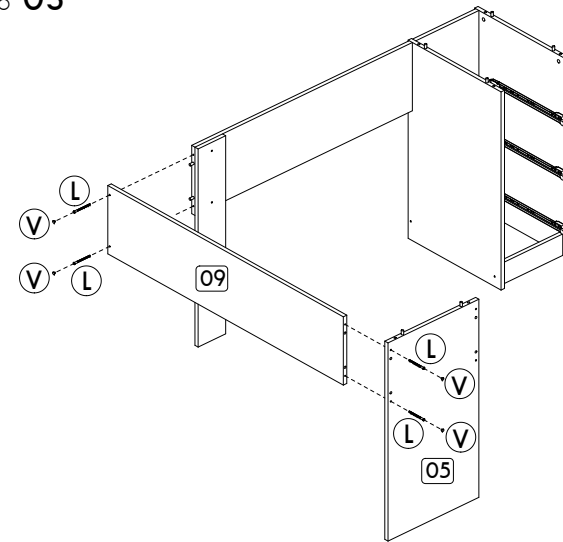

Passo/ Step/ Paso 04

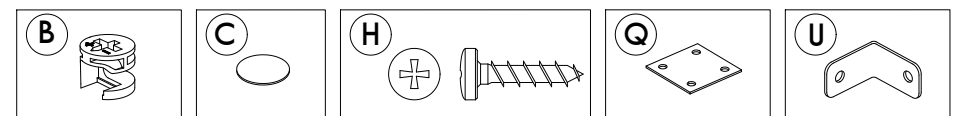
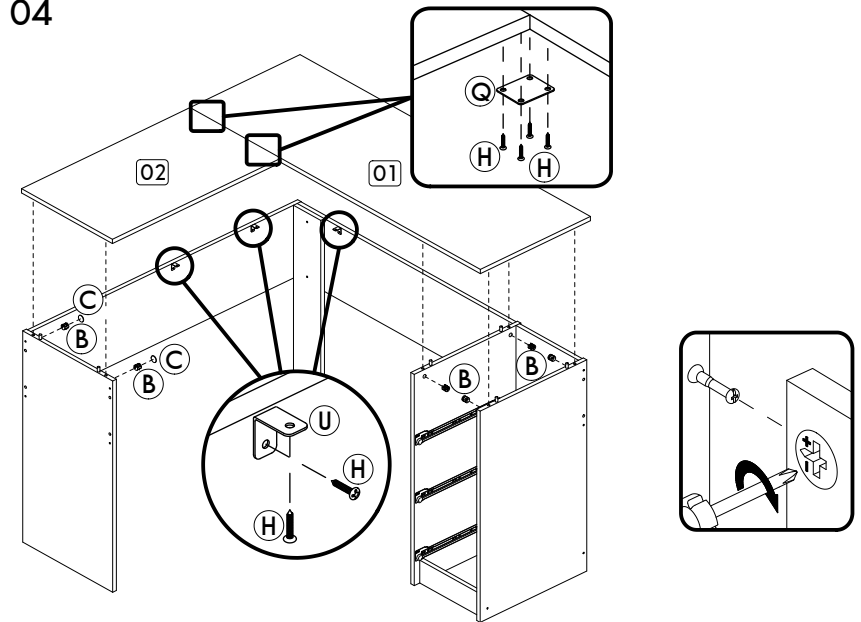

Passo/ Step/ Paso 05

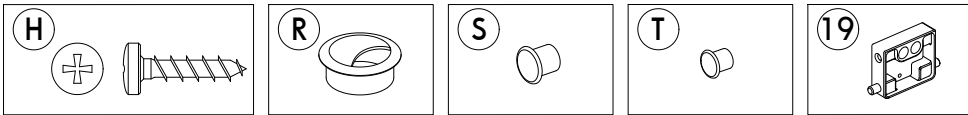
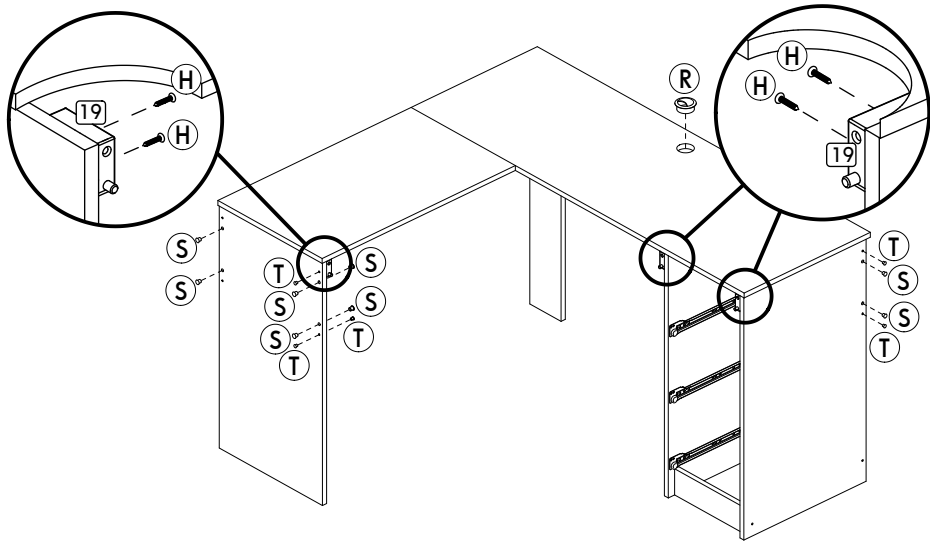

Passo/ Step/ Paso 06

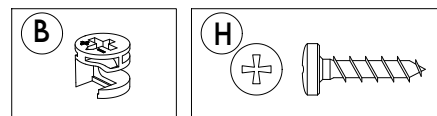
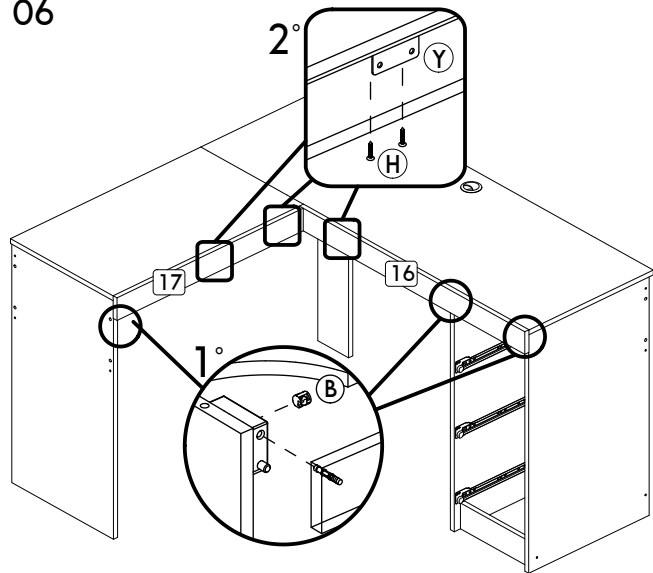

Passo/ Step/ Paso 07

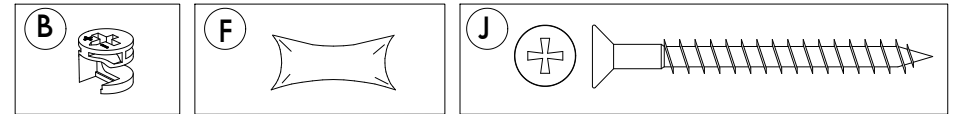
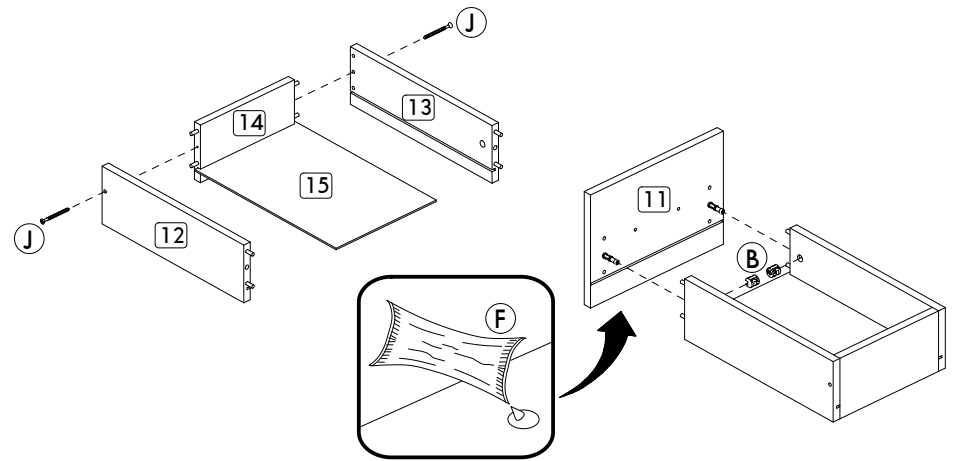

Passo/ Step/ Paso 08

