

MANUAL DE MONTAGEM
Assembly instructions / Instrucciones de armado

MESA RESENDE

Office Table Resende
Escritorio Resende

Código 1105 | Revisão 10

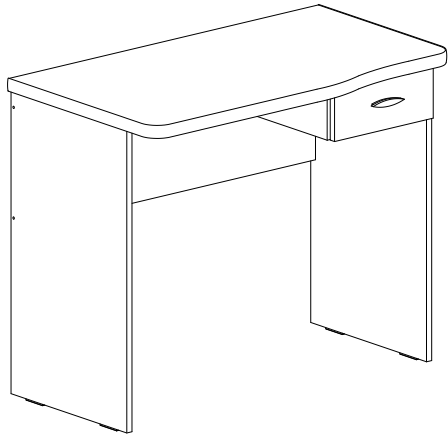

PESO MÁXIMO SUPORTADO PELAS PEÇAS, SENDO ESTE DISTRIBUÍDO UNIFORMEMENTE.

Maximum weight supported by parts, being this evenly distributed.
Peso máximo soportado por las partes, siendo esta distribuido uniformemente.

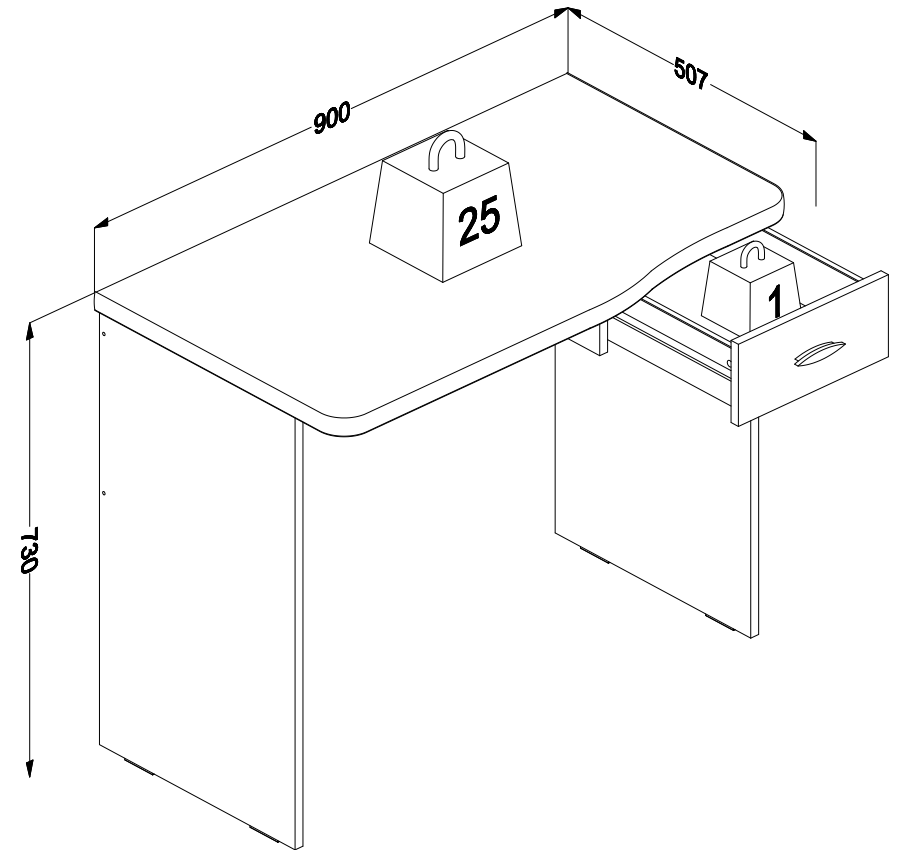

Você vai precisar de/ You will need / Usted necesitará

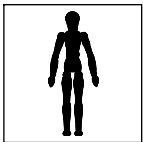

1 Pessoa
1 person
1 persona

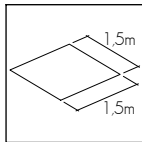

Espaço recomendado para montagem
Recommended space for assemble
Espacio recomendado para el armado

Ferramentas não inclusas
Tools not included / Herramientas no incluidas

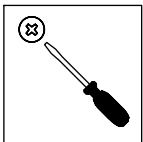

Chave Philips
Screwdriver
Destornillador cruz

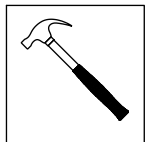

Martelo
Hammer
Martillo









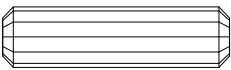
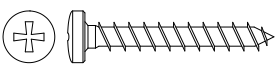
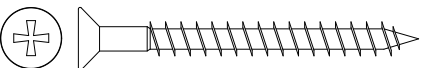
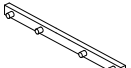

* PESO EM KG/ Weight in Kg/ Peso en Kg
DIMENSÕES EM MM/ Dimensions in mm/ Dimensiones en mm

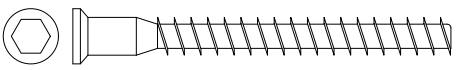
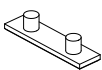
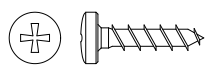
IDENTIFICAÇÃO DOS ACESSÓRIOS/ IDENTIFICATION OF ACCESSORIES/ IDENTIFICACIÓN DE ACCESORIOS

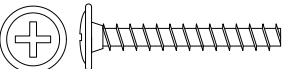
NOTAS: A separação dos acessórios antes de iniciar a montagem facilitará a mesma. Os parafusos e cavilhas estão na escala real. Em caso de dúvida na identificação, coloque o acessório sobre a imagem.

NOTES: The separation of the accessories before you start the assembly will facilitate the same. The screws and dowels are in real scale. In case of doubts about the identification, place the accessory on the image.

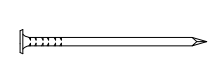
NOTAS: La separación de los accesorios antes de comenzar el armado facilitará el mismo. Los tornillos y taquetes son en escala real. En caso de dudas sobre la identificación, coloque el accesorio en la imagen.

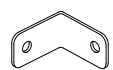
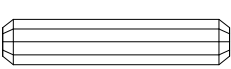
A		Cavilha Wooden Dowel Pin	8x30 mm	09	P		Parafuso panela Pan head screw Tornillo de pan	4,5x25 mm	02
B		Parafuso chato Flat head screw Tornillo de cabeza plana	4,5x45 mm	01	12		Corrediça plástica Plastic slide Corredera plástica	-	02
C		Chave allen Allen key Llave Allen	-	01					
D		Parafuso estrutural Structural screw Tornillo estrutural	5,0x50 mm	04					
E		Sapata Plastic Foot Pie Plástico	15x58 mm	04					
F		Parafuso panela Pan head screw Tornillo de pan	3,5x14 mm	10					
G		Trapézio Trapeze Trapecio	-	02					
H		Parafuso flangeado Flanged head screw Tornillo de cabeza flangeada	3,5x25 mm	02					
I		Tampa parafuso estrutural Structural screw cover Tapa tornillo estrutural	-	04					
J		Puxador Handle Tirador	32mm	01					
K		Parafuso chato Flat head screw Tornillo de cabeza plana	3,0x30 mm	04					
L		Prego Nail Clavo	10 x10	03					
M		Cola Glue Pegamento	13g	01					
N		Cantoneira de metal Metal bracket Soporte de metal	22x22 mm	05					
O		Cavilha Wooden Dowel Pin	6x30 mm	04					

IDENTIFICAÇÃO DAS PEÇAS/ PARTS IDENTIFICATION/ IDENTIFICACIÓN DE LAS PIEZAS

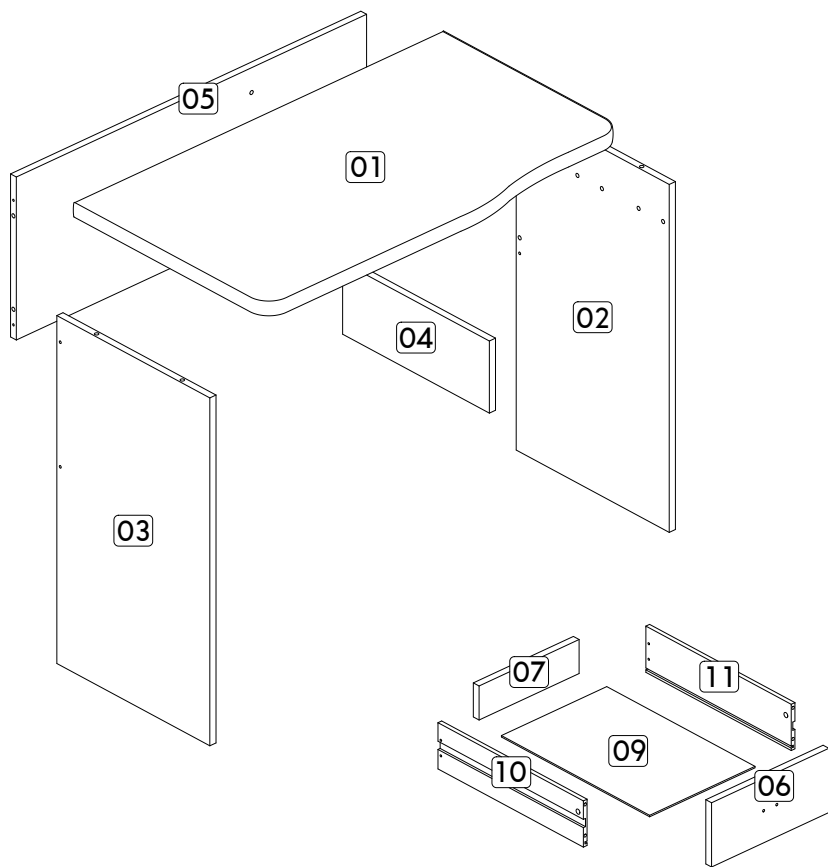

Nº	DESCRIÇÃO - DESCRIPTION - DESCRIPCIÓN	MEDIDAS-MEASURES - MEDIDAS (mm)	QTD.
01	Base superior - Top base - Base superior	896 x 505 x 15	01
02	Lateral direita - Right side - Lateral derecha	715 x 400 x 15	01
03	Lateral esquerda - Left side - Lateral izquierda	715 x 400 x 15	01
04	Divisão suporte gaveta - Drawer divider support - Divisória soporte cajón	384 x 148 x 15	01
05	Costa - Back - Fondo	335 x 851 x 15	01
06	Frente de gaveta - Drawer front - Frente del cajón	285 x 132 x 15	01
07	Traseiro de gaveta - Rear of drawer - Trasero del cajón	244 x 80 x 15	01
09	Fundo de gaveta - Bottom of drawer - Fondo del cajón	384 x 252 x 03	01
10	Lateral esquerda de gaveta - Left side of drawer - Lateral izquierda del cajón	380 x 95 x 09	01
11	Lateral direita de gaveta - Right side of drawer - Lateral derecha del cajón	380 x 95 x 09	01

PRÉ-MONTAGEM / PRE-ASSEMBLE / PRE ARMADO

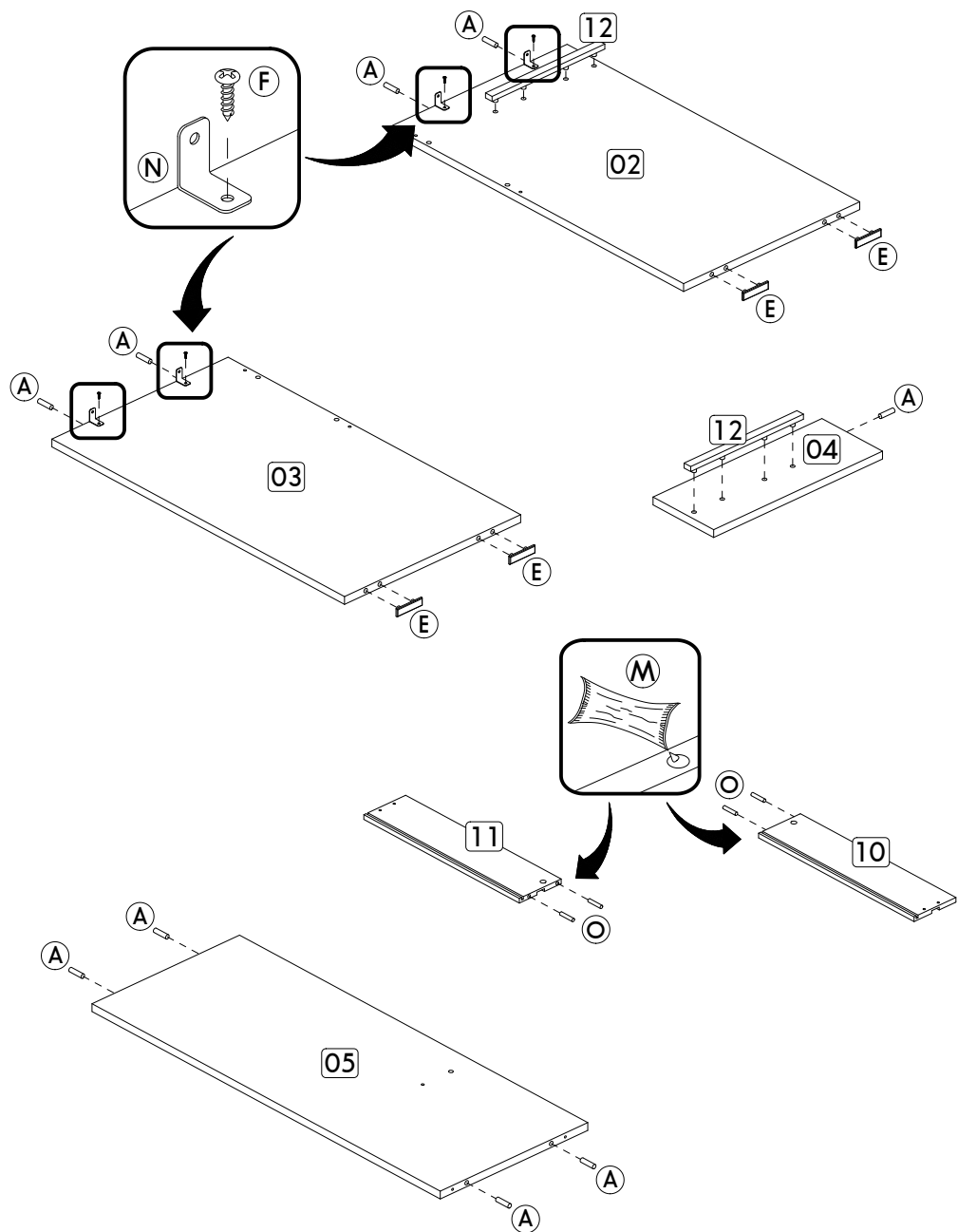

MONTAGEM / ASSEMBLY / ARMADO

Passo/ Step/ Paso 01

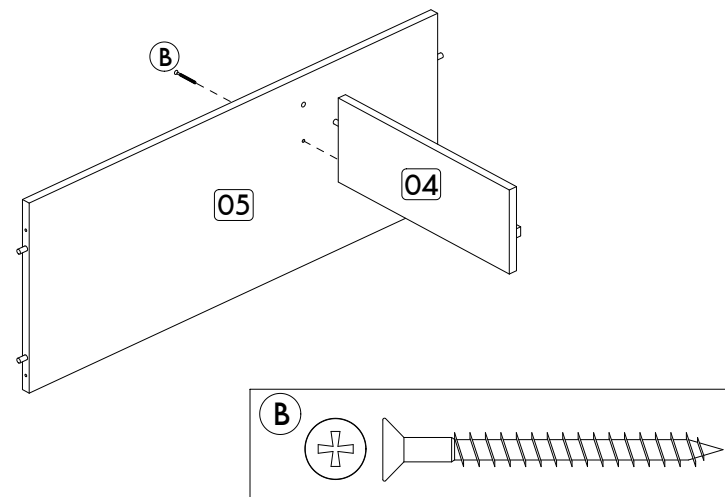

Passo/ Step/ Paso 02

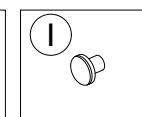
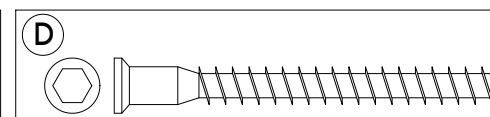
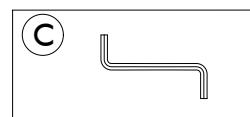
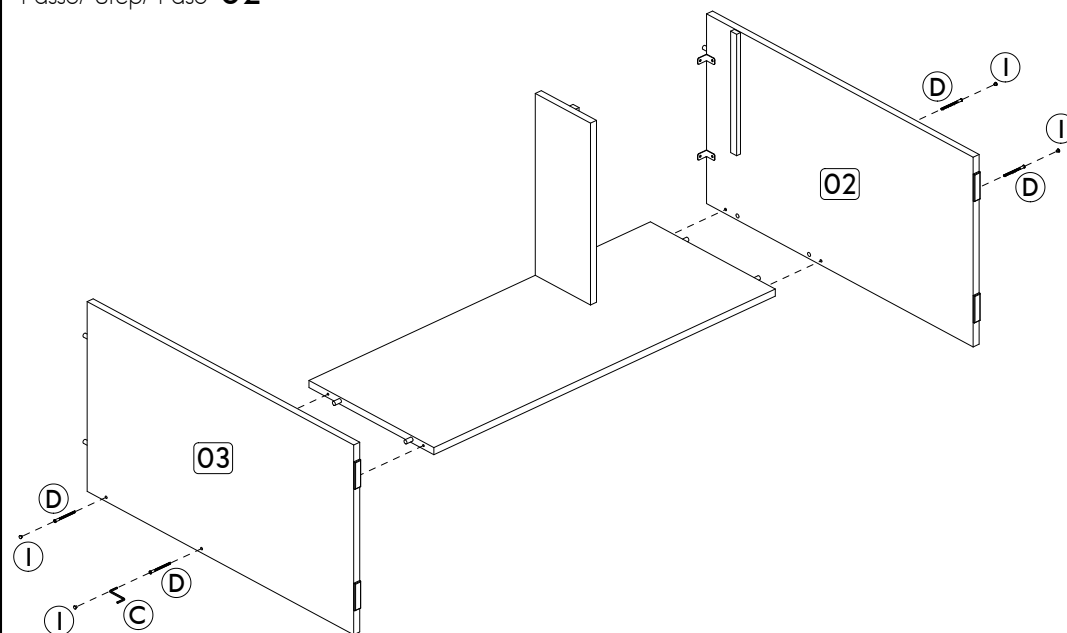

Passo/ Step/ Paso 03

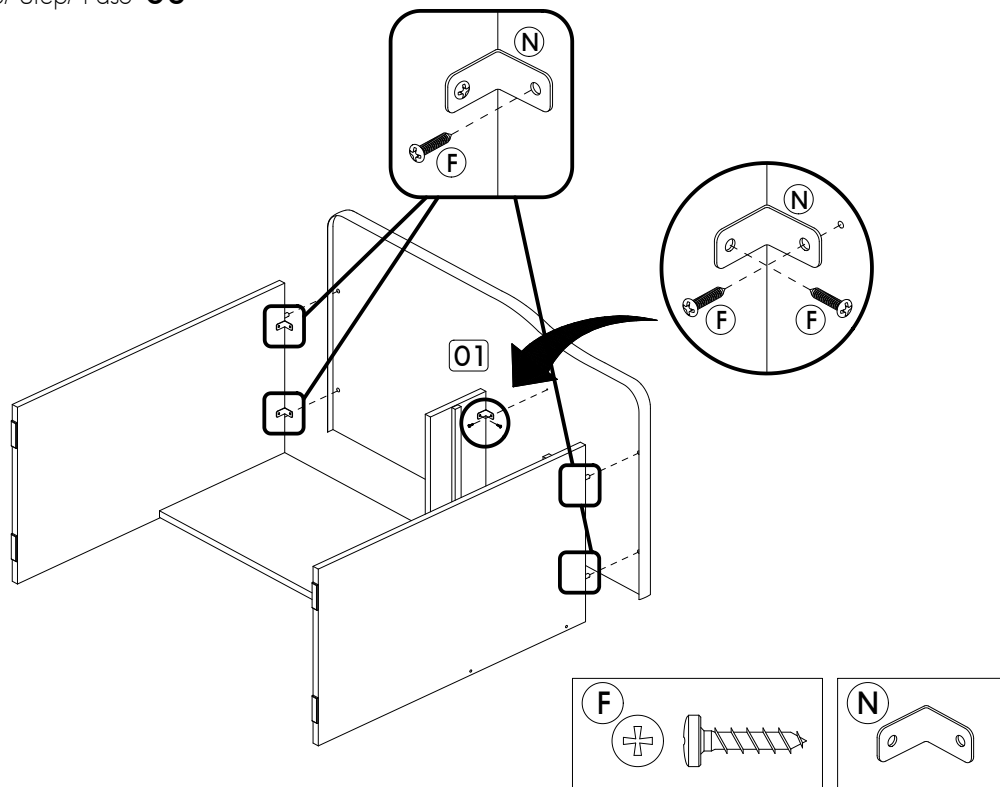

Passo/ Step/ Paso 04

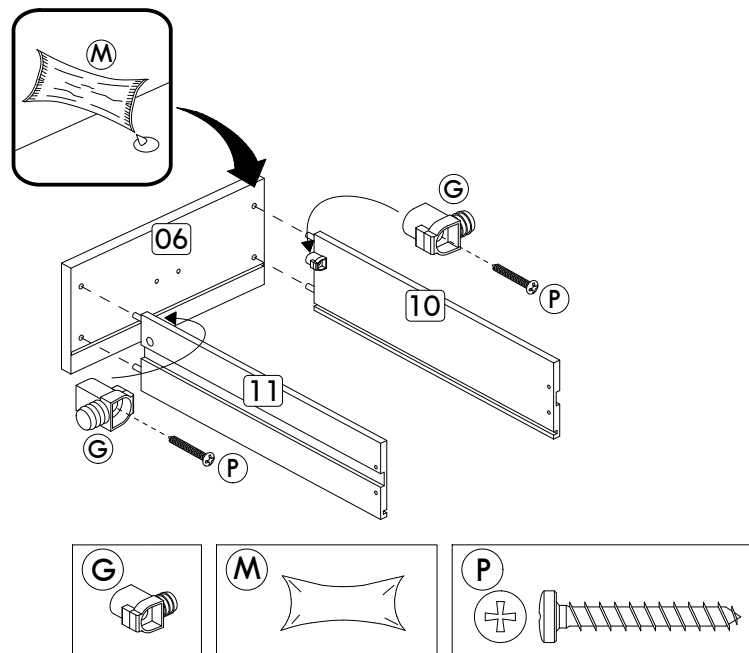

Passo/ Step/ Paso 05

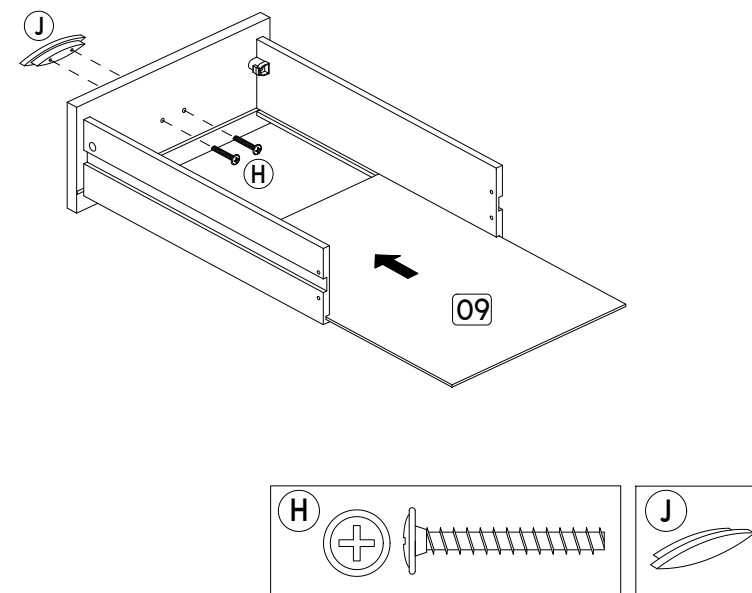

Passo/ Step/ Paso 06

