

## ESTANTE COM VISTAS

Bookcase w/ frames  
Estantería c/ molduras

Código 2141 | Revisão 09

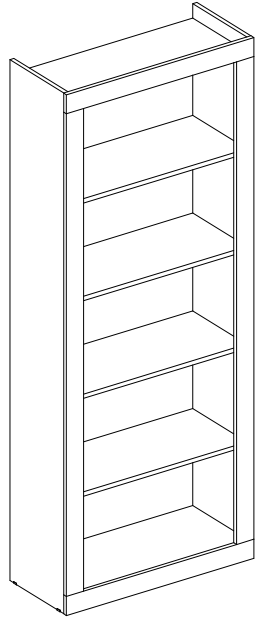

### PESO MÁXIMO SUPORTADO PELAS PEÇAS, SENDO ESTE DISTRIBUÍDO UNIFORMEMENTE.

Maximum weight supported by parts, being this evenly distributed.  
Peso máximo soportado por las partes, siendo esta distribuido uniformemente.

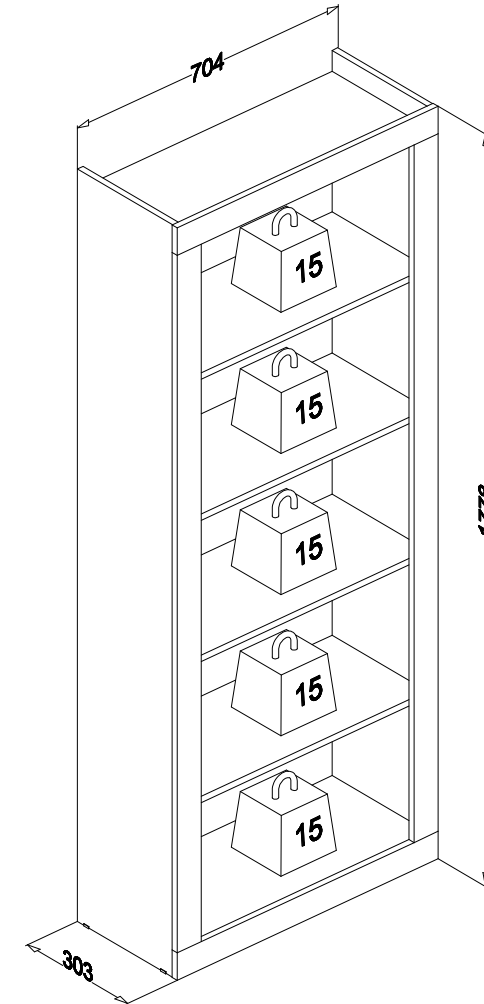

### Você vai precisar de/ You will need / Usted necesitará

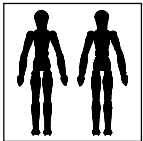

2 Pessoas  
2 people  
2 personas

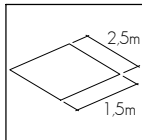

Espaço recomendado para montagem  
Recommended space for assemble  
Espacio recomendado para el armado

Ferramentas não inclusas  
Tools not included / Herramientas no incluidas

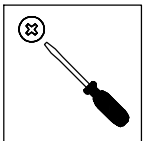

Chave Philips  
Screwdriver  
Destornillador cruz



Martelo  
Hammer  
Martillo







\* PESO EM KG/ Weight in Kg/ Peso en Kg  
DIMENSÕES EM MM/ Dimensions in mm/ Dimensiones en mm

**IDENTIFICAÇÃO DOS ACESSÓRIOS / IDENTIFICATION OF ACCESSORIES/ IDENTIFICACIÓN DE ACCESORIOS**

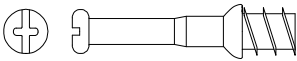
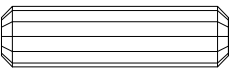
**NOTAS:** A separação dos acessórios antes de iniciar a montagem facilitará a mesma. Os parafusos e cavilhas estão na escala real. Em caso de dúvida na identificação, coloque o acessório sobre a imagem.

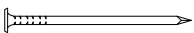
**NOTES:** The separation of the accessories before you start the assembly will facilitate the same. The screws and dowels are in real scale. In case of doubts about the identification, place the accessory on the image.

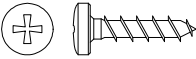
**NOTAS:** La separación de los accesorios antes de comenzar el armado facilitará el mismo. Los tornillos y taquetes son en escala real. En caso de dudas sobre la identificación, coloque el accesorio en la imagen.

<b>A</b>		<b>Tambor minifix</b> Drum lock Tambor minifix	12 mm	<b>16</b>
<b>B</b>		<b>Haste minifix simples</b> Simple minifix screw Tornillo minifix simple	-	<b>16</b>
<b>C</b>		<b>Cavilha</b> Wooden Dowel Pin	8x30 mm	<b>32</b>
<b>D</b>		<b>Cantoneira de metal</b> Metalic angle plates Soporte de metal	46 mm	<b>06</b>
<b>E</b>		<b>Prego</b> Nail Clavo	10 x10	<b>65</b>
<b>F</b>		<b>Sapata</b> Small plastic foot Pie plástico	15 mm	<b>04</b>
<b>G</b>		<b>Cantoneira de metal</b> Metal bracket Soporte de metal	22x22 mm	<b>04</b>
<b>H</b>		<b>Parafuso panela</b> Pan head screw Tornillo de pan	3,5x14 mm	<b>32</b>
<b>I</b>		<b>Garra de metal</b> Metal claw Garra metal	15 mm	<b>12</b>

**IDENTIFICAÇÃO DAS PEÇAS/ PARTS IDENTIFICATION/ IDENTIFICACIÓN DE LAS PIEZAS**

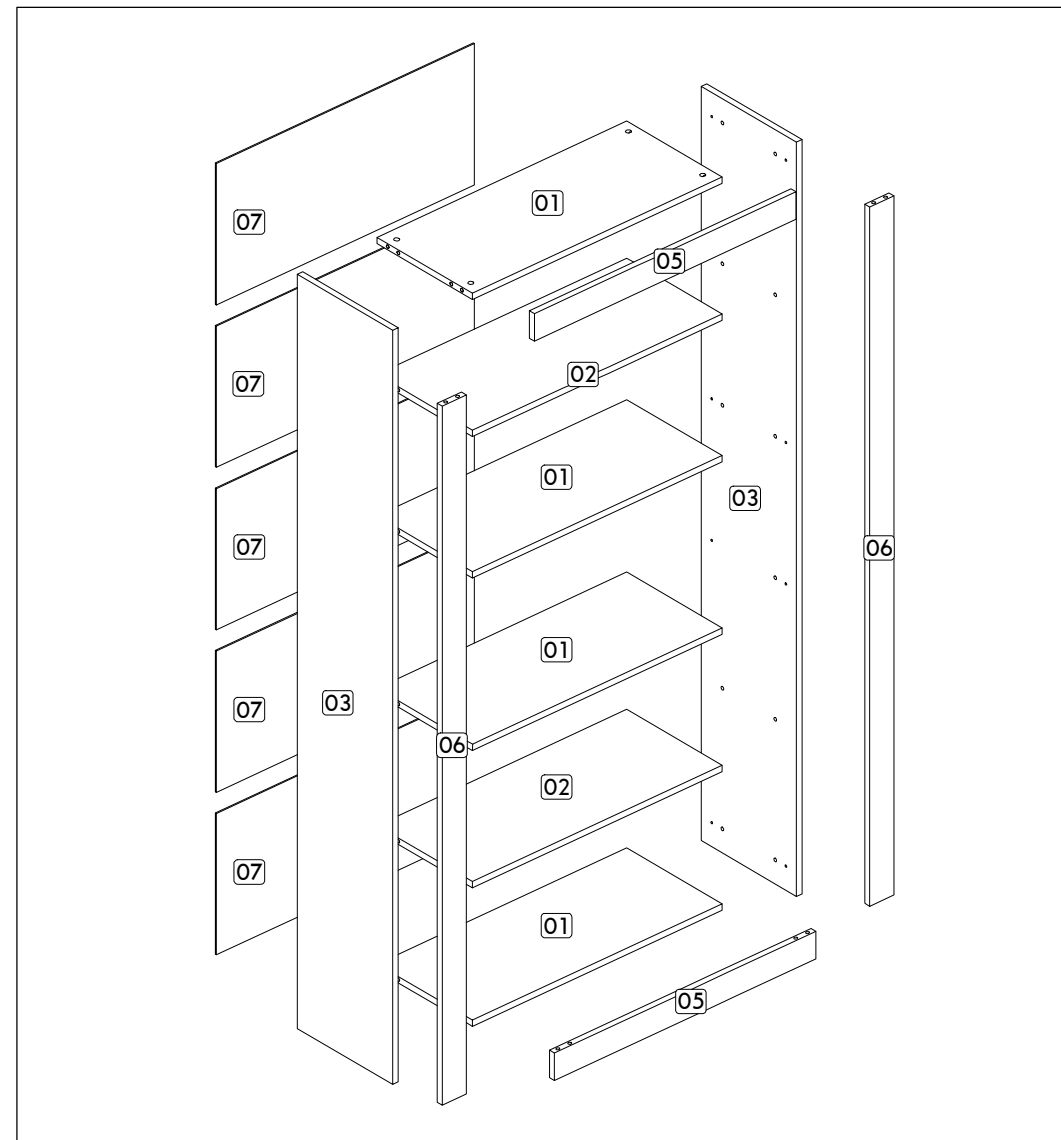

Nº	DESCRIÇÃO - DESCRIPTION - DESCRIPCIÓN	MEDIDAS-MEASURES - MEDIDAS (mm)	QTD.
01	<b>Base</b> - Base - Base	672 x 288 x 15	04
02	<b>Base prateleira</b> - Base shelf - Base de la repisa	672 x 288 x 15	02
03	<b>Lateral direita/esquerda</b> - Right/left side - Lateral derecha/izquierda	1778 x 288 x 15	02
05	<b>Rodapé superior/inferior</b> - Top/bottom footer - Superior/inferior rodapie	704 x 65 x 15	02
06	<b>Vista frontal</b> - Front frame - Moldura el frente	1648 x 65 x 15	02
07	<b>Costa</b> - Back - Fondo	694 x 333 x 3	05

PRÉ-MONTAGEM/ PRE-ASSEMBLE/ PRE ARMADO

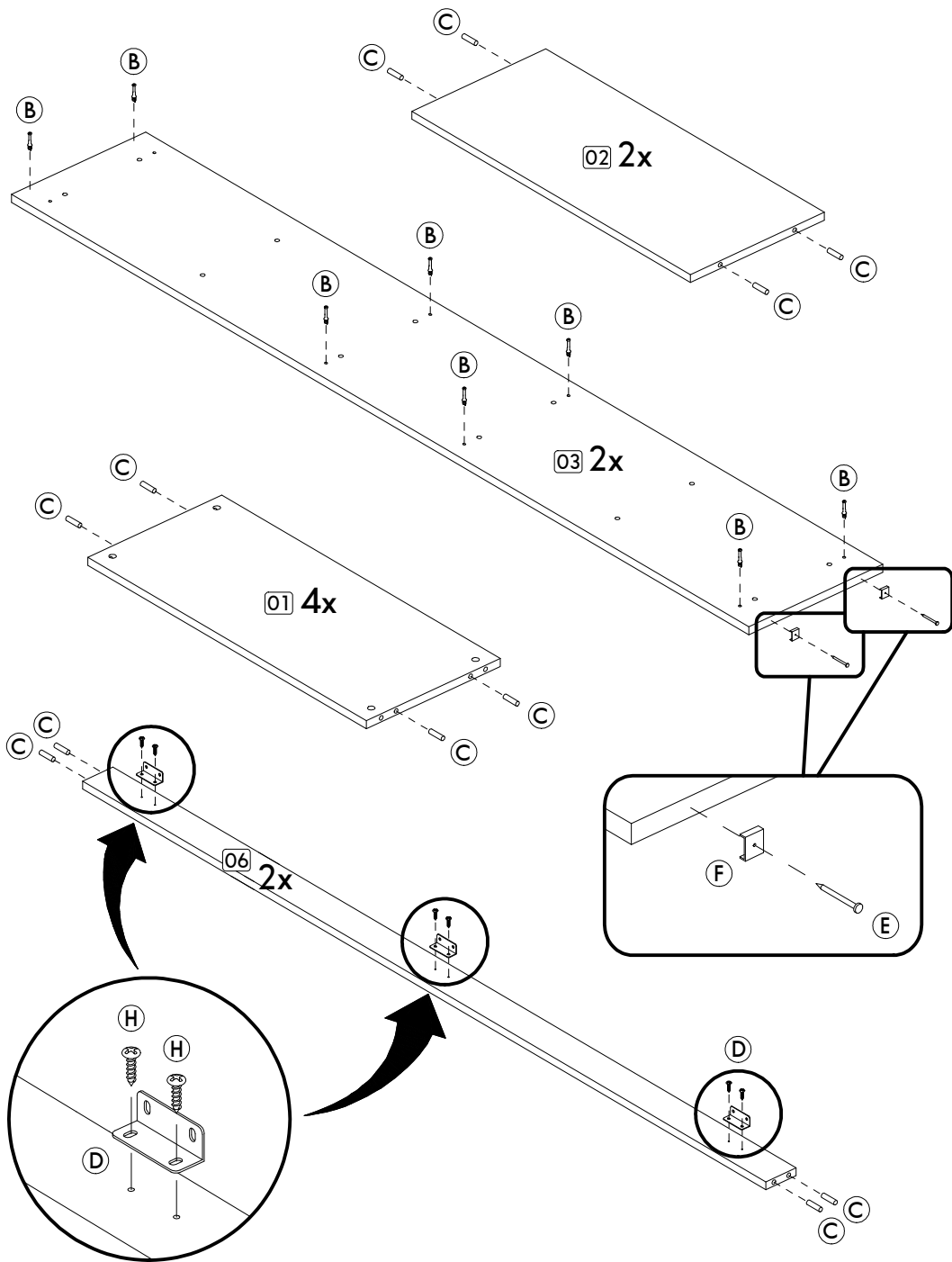

MONTAGEM/ ASSEMBLY/ ARMADO

Passo/ Step/ Paso 01

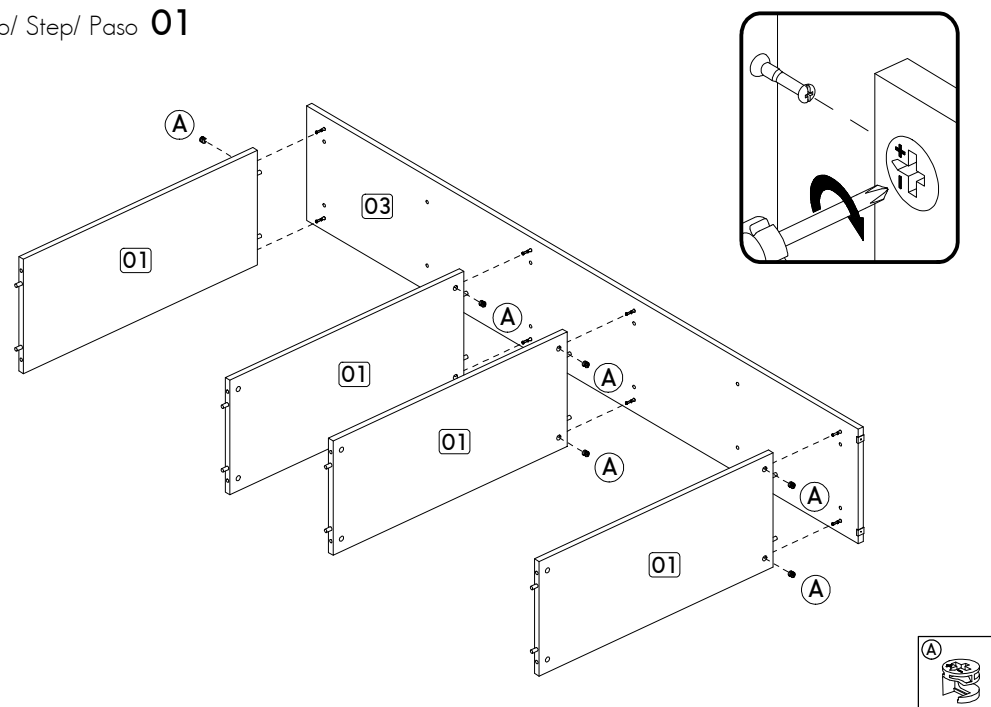

Passo/ Step/ Paso 02

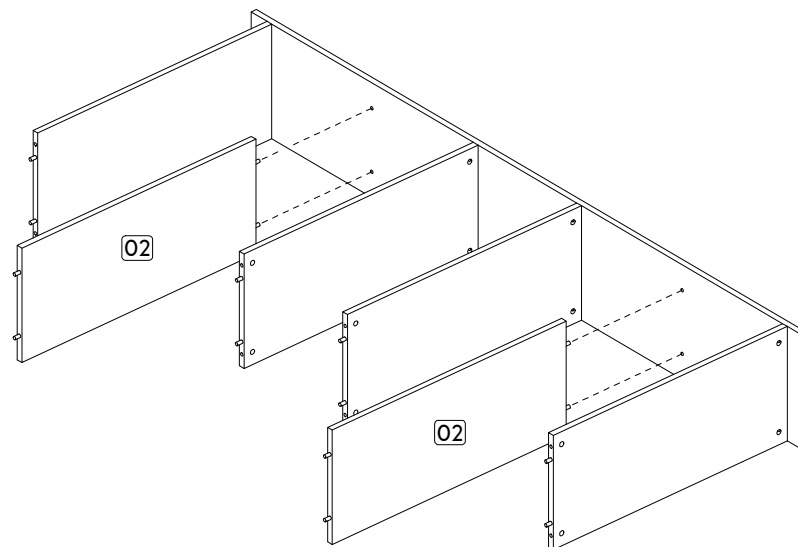

Passo/ Step/ Paso 03

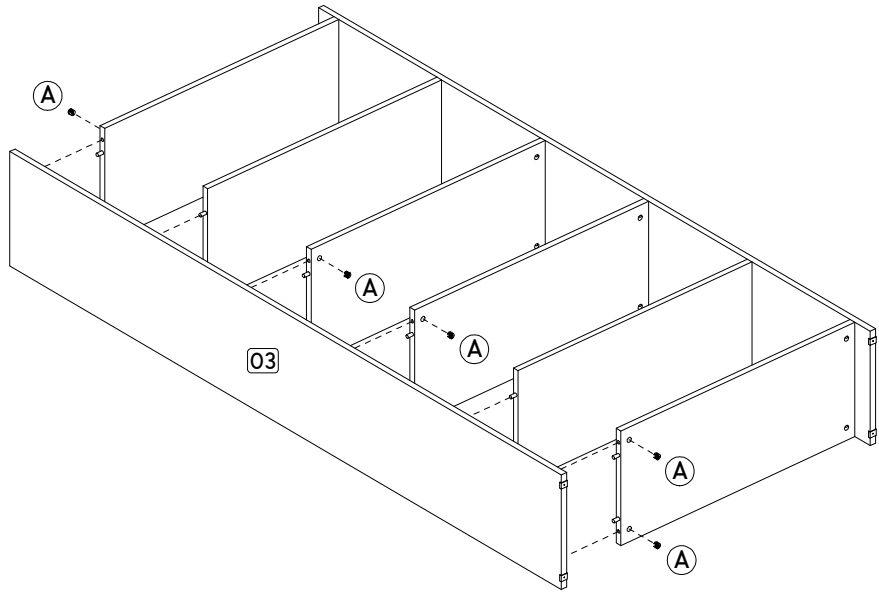

Passo/ Step/ Paso 04

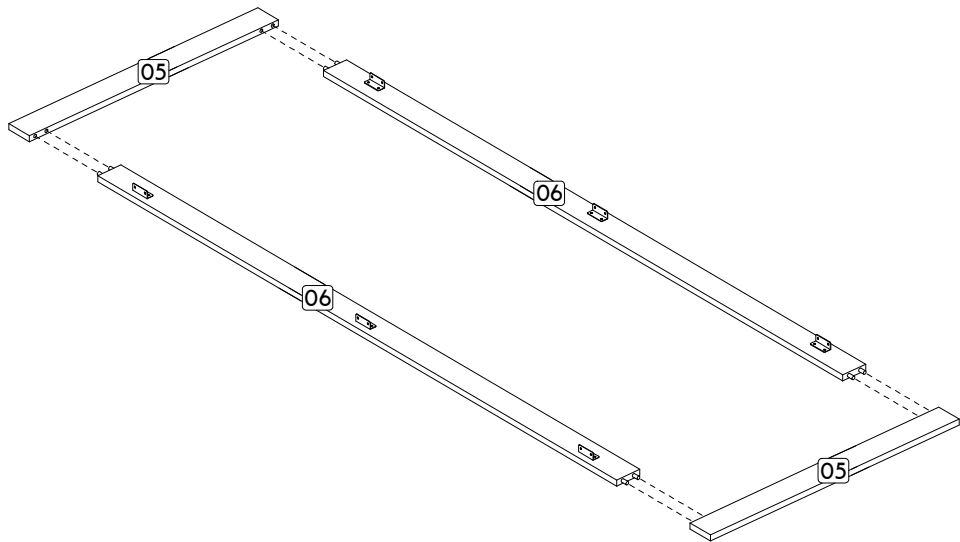

Passo/ Step/ Paso 05

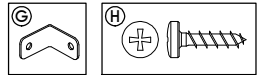
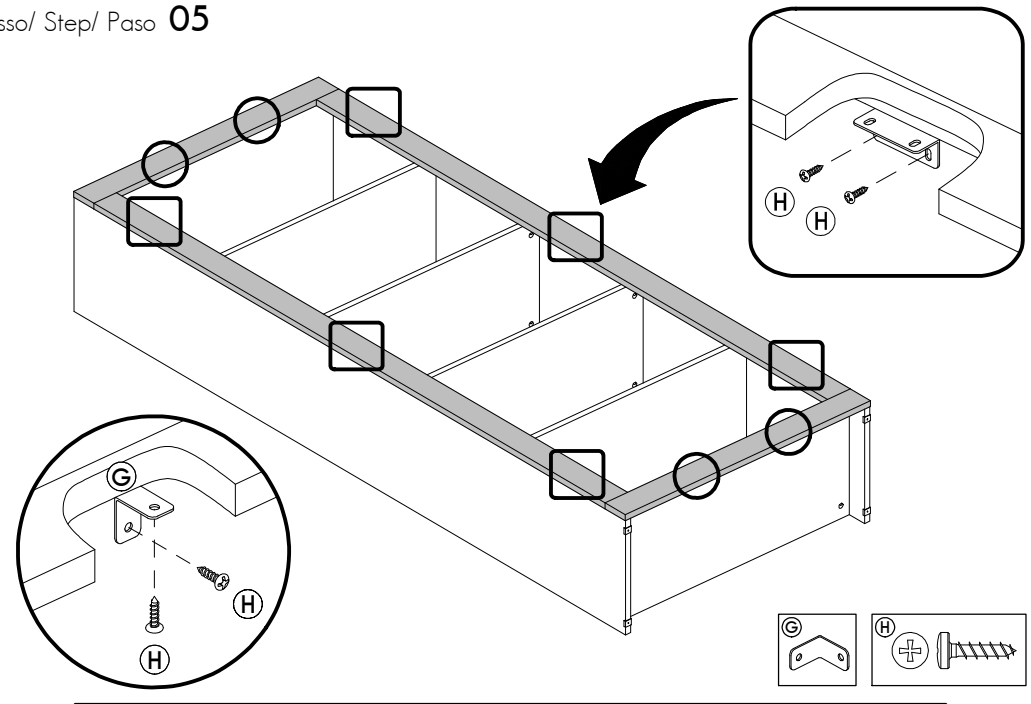

Passo/ Step/ Paso 06

