

Roupeiro Smart Glass 2P / Wardrobe Smart Glass 2P / Roupeiro Smart Mirror 2P.

1º Passo / Step / Paso

Inicie montando a base do roupeiro fixando as divisões pé centrais (12), o traseiro pé (11) e a frente pé (10), utilizando cantoneiras (M) e parafusos (B) /

Start by mounting the base of the wardrobe securing the foot divisions Centra (12), the hind foot (11) and the forward foot (10), using Cantoneirase (M) screws (B) /

Inicie montando una base de roupeiro fijando como divisões pé Centrais (12), o traseiro pé (11) e a frente pé (10) mediante la utilización de Cantoneirase (M) parafusos (B).

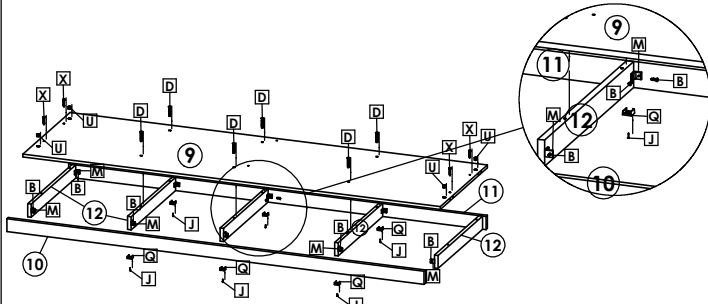

A Frente Pé (10) é alinhada pela frente da borda do Tampo inferior (9) /

The Fore foot (10) is aligned with the front edge of the bottom (9) /

Un Frente Pé (10) é alinhado por frente de la borda del tampo inferior (9) /

Frente Pé / Front foot

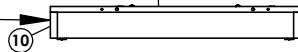

2º Passo / Step / Paso

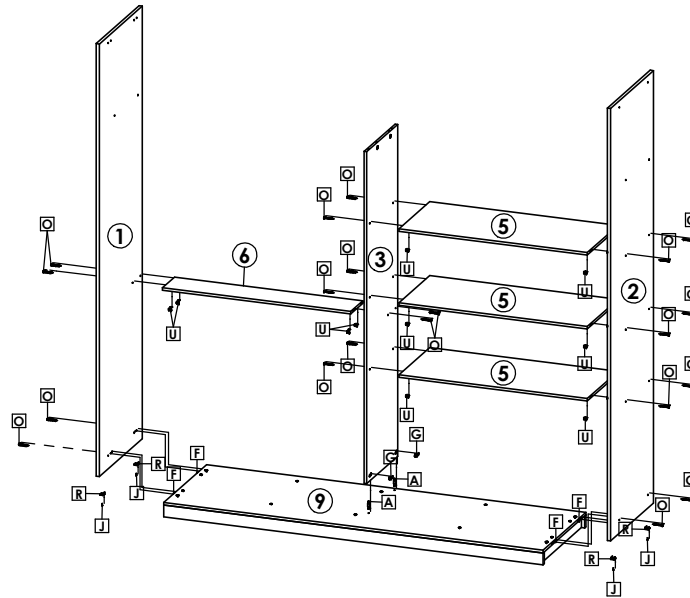

3º Passo / Step / Paso

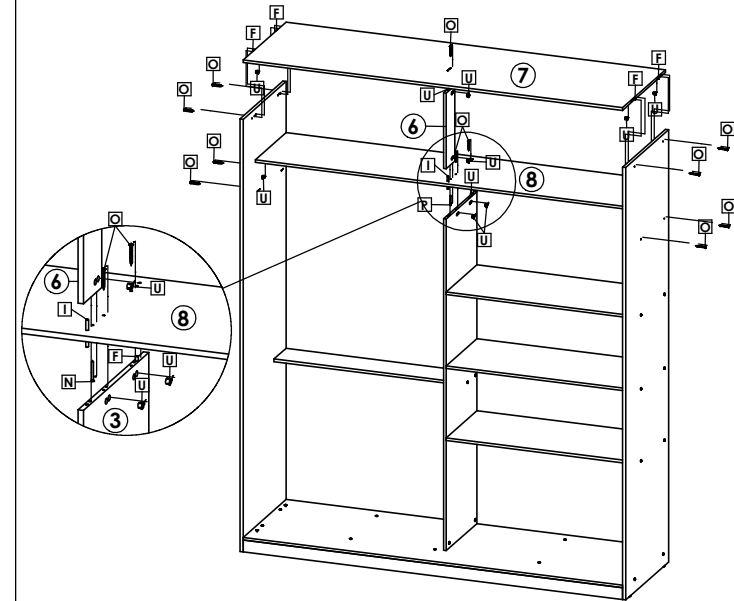

4º Passo / Step / Paso

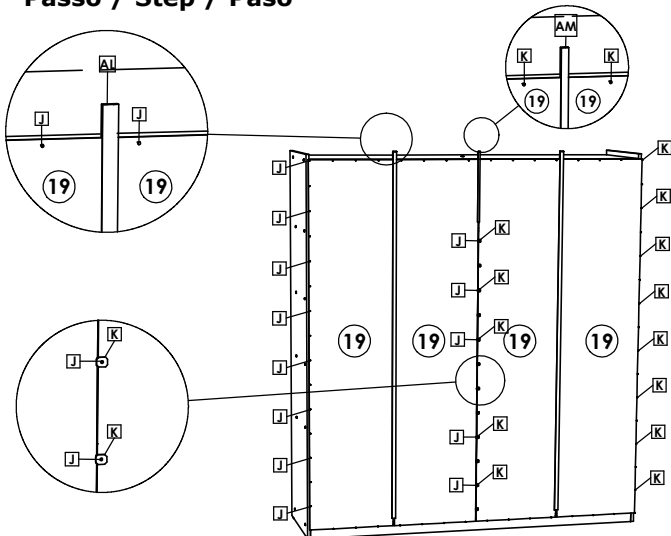

Inicie a montagem pelo Fundo Central posicionando-o no centro. Após, faça a fixação com pregos (J). Nas junções entre fundos, utilize pregos (J), presilhas (K), Perfil H (H) e Perfil I (I) /

Start the assembly by the Central Bottom by positioning it in the center. Then, fasten with nails (J). At the junctions between the bottoms, use nails (J), pins (K), Profile H (H) and Profile I (I) /

Inicie el montaje por el Fondo Central colocándolo en el centro. Después, haga la fijación con clavos (J). En los empalmes entre fondos, utilice clavos (J), pinzas (K), Perfil H (H) y Perfil I (I) /

5º Passo / Step / Paso

As molduras possuem um rasgo que servem de guia para o posicionamento das cantoneiras /

The frames have a feature that guides the positioning of the angles /

Los marcos poseen un rasgo que sirven de guía para el posicionamiento de las cantoneiras.

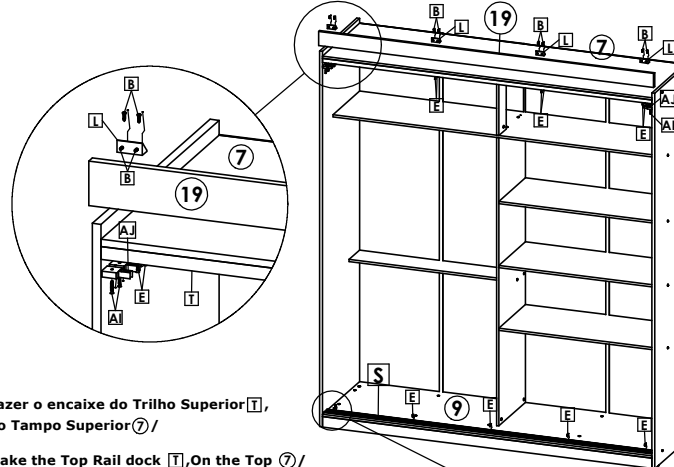

Fazer o encaixe do Trilho Superior (T), no Tampo Superior (7) /

Make the Top Rail dock (T), On the Top (7) /

Hacer el encaje del riel superior (T), en el tablero superior (7).

Posicionar o Trilho Inferior (S) a 25mm da borda do Tampo Inferior (9) /

Position the Rail Less (S) than 25mm from the edge of the Lower Top (9) /

Posicionar el Carril Inferior (S) a 25mm del borde del Tablero inferior (9).

6º Passo / Step / Paso

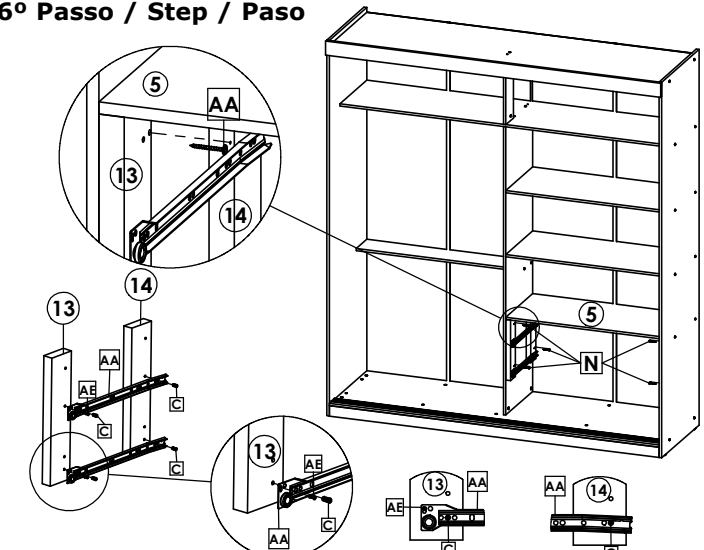

Faça a montagem externa do conjunto distanciador+corrediça, alinhando as corrediças pelo segundo furo. Após faça a fixação do conjunto com parafusos (C) e (AE) /

Make the outer assembly of the spacer + slide assembly aligning the slides through the second hole. After fixing the assembly with screws (C) and (AE) /

El montaje exterior del conjunto distanciador + corredera, alineando las diapositivas por el segundo agujero. Después de hacer la fijación del conjunto con tornillos (C) e (AE).

Roupeiro Smart Glass 2P / Wardrobe Smart Glass 2P / Roupeiro Smart Mirror 2P.

7º Passo / Step / Paso



Utilizar gabarito para fixação do Cabideiro somente no Calceiro.

Use mounting template Only in the Shoemaker.

Uso de la plantilla de fijación Del Caballero sólo en el Calceiro.

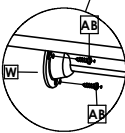

Faça a colocação das gavetas e cabideiros.

Lay out drawers and racks.

Coloque los cajones y los caballetes.

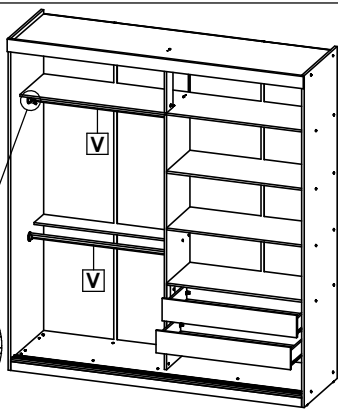

Peso Suportado / Weight supported / peso que soporta

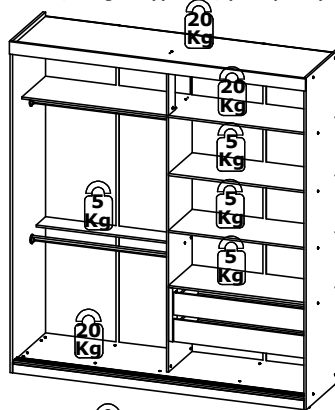

Peso Suportado por cada gaveta
Weight Supported per drawer
Peso soportado por cada cajón



Montagem Portas | Doors Assembly | Montaje Puertas

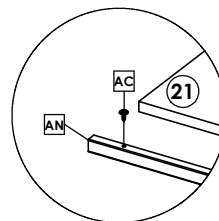

Fixar na Porta (21) as Cantoneiras AN, com Parafusos AC /

Attach Door (21) to Angles AN, with Screws AC /

Fijar en la Puerta (21) las Cantoneiras AN, con Tornillos AC.

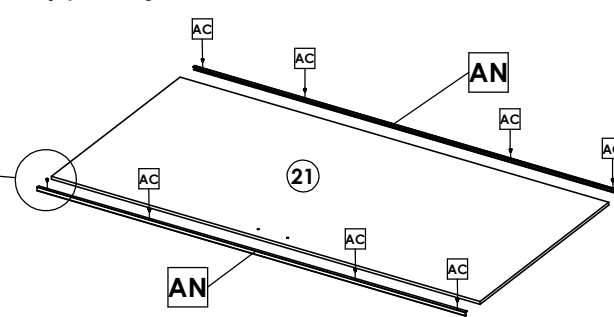

É de extrema importância que a montagem das portas seja feita sobre uma superfície totalmente plana, para evitar qualquer tipo de empenamento.

It is extremely important that the doors are assembled on a completely flat surface to avoid any kind of warpage.

Es de extrema importancia que un montaje de las puertas se hizo sobre una superficie totalmente plana, para evitar cualquier tipo de empenamiento.

Montagem Portas | Doors Assembly | Montaje Puertas

Iniciar a montagem dos Guias Superiores AF, posicionando-os a 30mm da Cantoneira U AN e fixando-os com Parafusos AI /

Start the assembly of the Upper Guides AF, positioning them to 30mm of the U AN Angle and fixing them with Screws AI /

Iniciar el montaje de las guías superiores AF, colocándolas a 30 mm de la cantón U AN y fijándolas con tornillos AI.

Posicionar o Rodízio Inferior AG à 32mm da Cantoneira U AN /

Position the Rod Less AG than 32mm from the U-bracket AN /

Posicionar el Rodamiento Inferior a la 32mm de la Cantoneira U AN.

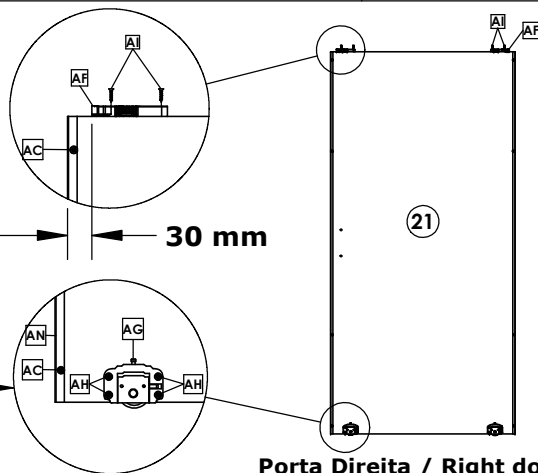

Porta Direita / Right door

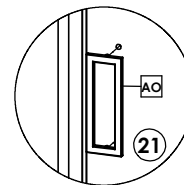

Encaixe os Puxadores AF no Furo das Portas (22) /

Attach Handles AF to Door Hole (22) /

Enchufe los tiradores AF en el agujero de las puertas (22).

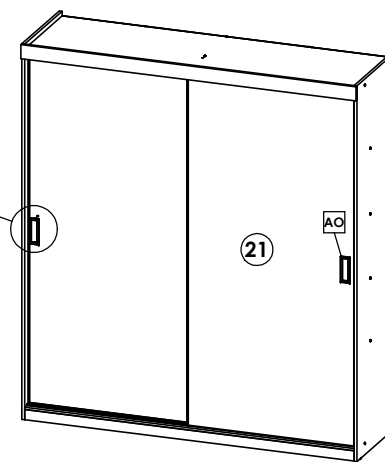

Kit montagem espelhos
Mirror Mounting Kit
Kit de montaje de espejos

AQ 2



Suporte Vidro Pino 25678

AR 2



Parafuso 3,5x14 CP (Zincado Branco) 34125

Inicie a montagem alinhando o Espelho (22) com a Cantoneira da Porta.

Após fixe-o com Suporte Vidro AQ e Parafuso AR, centralizando-o a 473mm da parte superior da porta /

Start the assembly by aligning the mirror (22) with the Door angle.

After securing it with Glass Support AQ and Screw AR, centering it at 473mm from the top of the door /

Inicie el montaje alineando el espejo (22) con la esquina de la puerta.

Después de fijarlo con Soporte Vidrio AQ y Tornillo AR, centralizándolo a 473mm de la parte superior de la puerta.

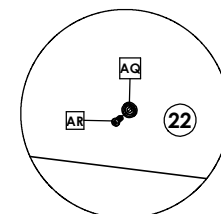
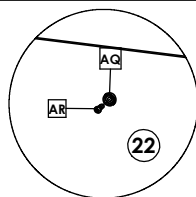

Smart Glass

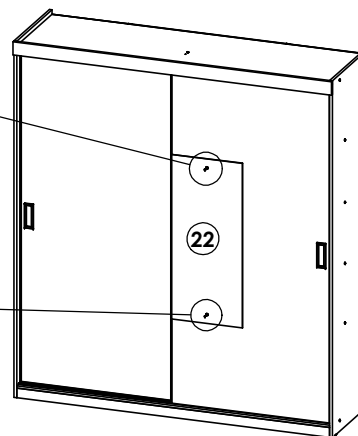

Smart

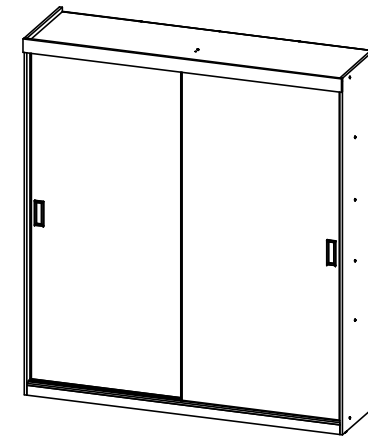



Faltos especialmente para você

Roupeiro Smart Glass 2P / Wardrobe Smart Glass 2P / Roupeiro Smart Mirror 2P.



Os Pés são opcionais/
Feet are optional /
Los Pies son opcionales.

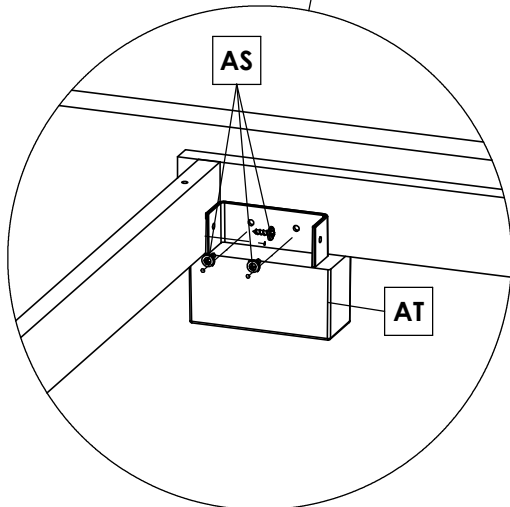
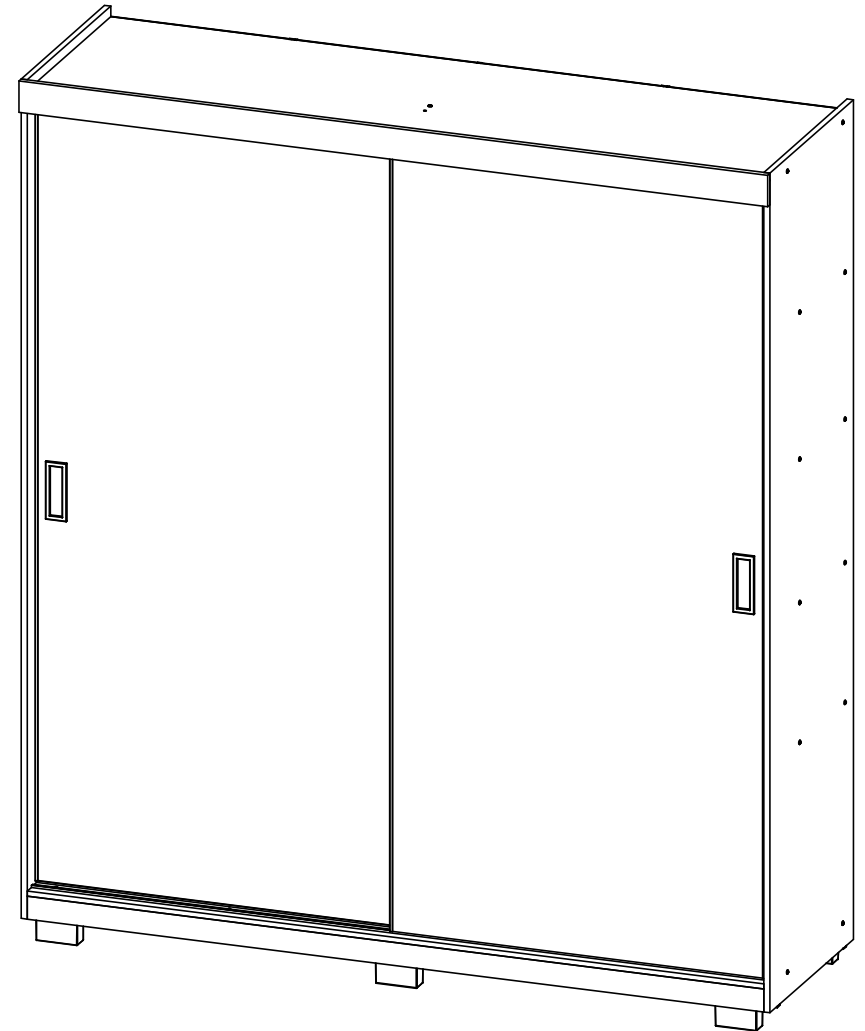
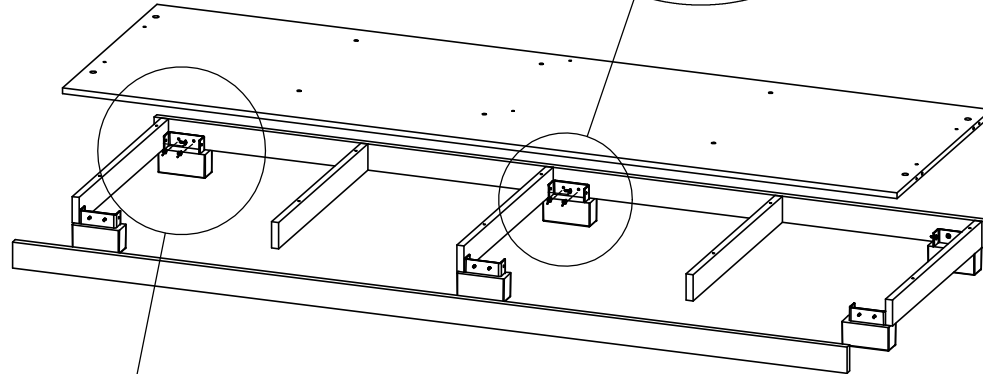
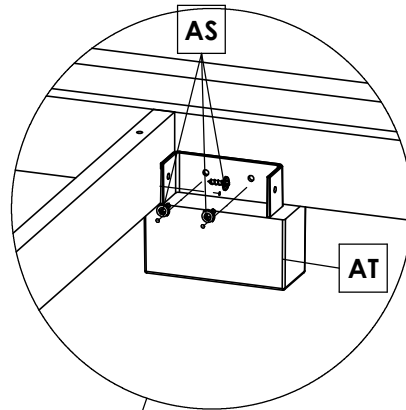

Na opção com Pés, fixar pès **AT** com Parafusos **AS** /

In the option with Feet, fix feet **AT** with Screws **AS** /

Na opção com Pés, fixar pès **AT** com Parafusos **AS** .

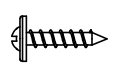
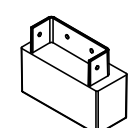
AS	18	AT	6
 Parafuso 4,0x12 CF 30518		 Pé Retangular 34701	