

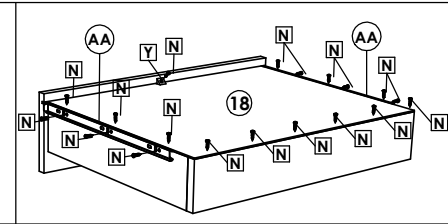

Roupeiro Sofisticatto Glass 2 Portas | Wardrobe Sofisticatto Glass 2 Doors | Ropero Sofisticatto Glass 2 Puertas

Montagem Gavetas

terça-feira, 12 de fevereiro de 2019

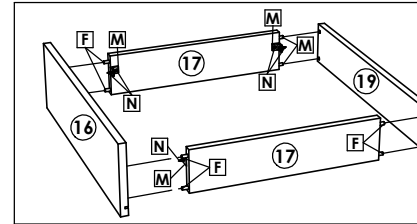
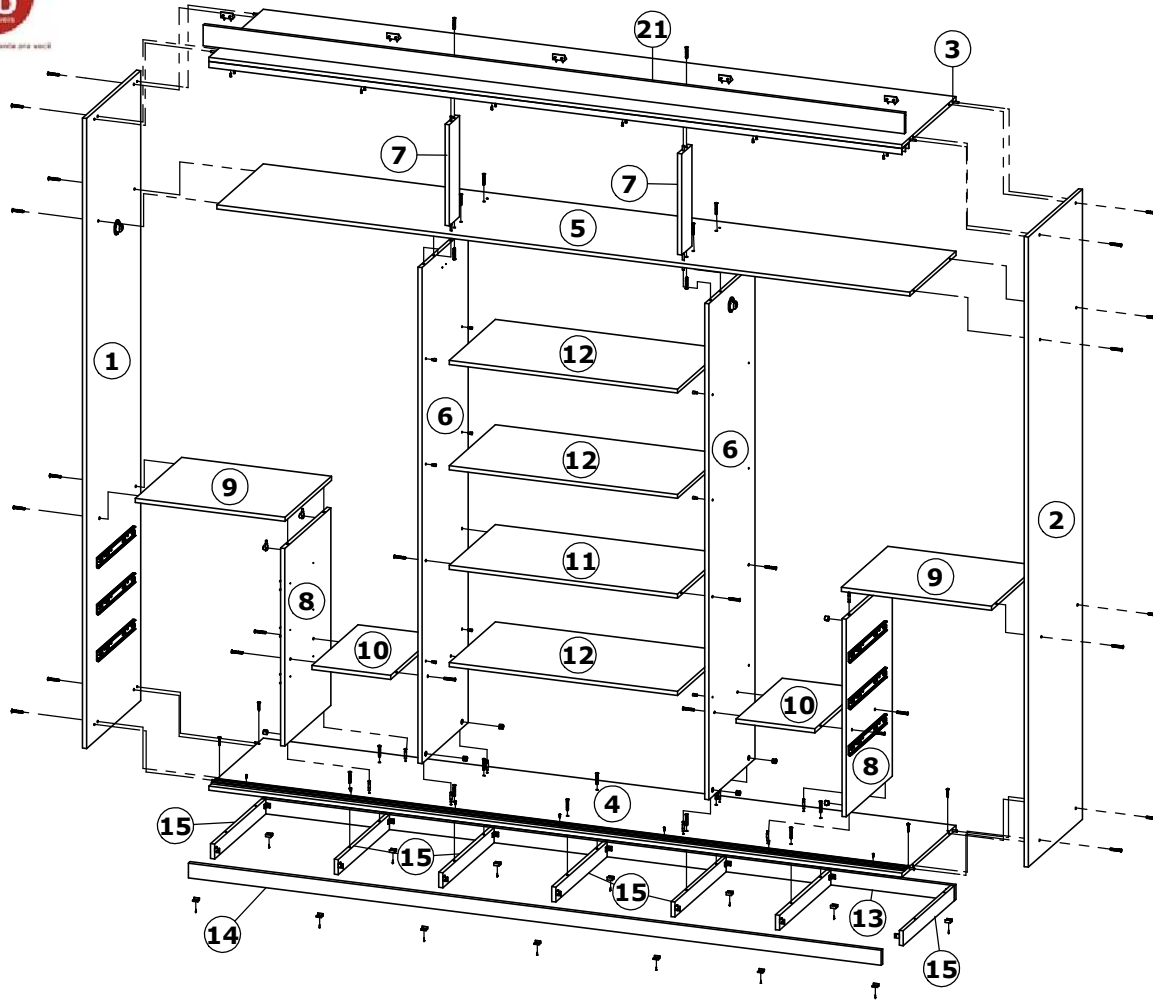

Roupeiro Sofisticatto Canela c| Linho

Peça Piece Pieza	Cod.	Descrição	Description	Descripción	Qtde Qty Cant	Compr Lenght Largo	Larg. Width Ancho	Esp. Thickness Espesor
1	P15500	Lateral Esquerda	Left Panel	Lateral Izquierda	1	2298	528	15
2	P15503	Lateral Direita	Right Panel	Lateral Derecha	1	2298	528	15
3	P15491	Tampos Superior	Top	Tapa Superior	1	2547	528	15
4	P15504	Tampo Inferior	Top	Tapa Inferior	1	2547	528	15
5	P15701	Tampo Intermediário	Intermediate Top	Tapa Intermediaria	1	2547	450	15
6	P15492	Divisão Esq/Dir	Left/Right Side Division	Division Izq/Der	2	1809	450	15
7	P15705	Divisão Maleiro	Division	Division	2	369	100	15
8	P15712	Divisão Calceiro/Gav.	Division fittings/Drawer	División Calcero/Cajón	2	721	449	15
9	P15702	Tampo Sup. Gaveta	Top Drawer Higher	Tapa Superior Cajón	2	551	450	15
10	P15711	Tampo Lat. Calceiro	Lateral Fittings Top	Tapa Lateral Calcero	2	290	449	15
11	P15704	Tampo	Cover	Tapa	1	839	450	15
12	P15703	Prateleira	Shelf	Repisa	3	839	450	15
13	P11686	Traseiro Pé	Back Bottom Frame	Zocalo Traseiro	1	2547	54,5	15
14	P15505	Frente Pé	Bottom Frame	Marco Inferior	1	2547	54,5	15
15	P15493	Divisão Pé	Division Bottom Frame	Division Zocalo	7	498	54,5	15
16	P15707	Frente Gaveta	Drawer Frontal	Frente del Cajón	6	524	145	15
17	P15709	Lateral Gaveta	Side Drawer	Lat del Cajón	12	385	88	15
18	P15710	Fundo Gaveta	Bottom Drawer	Fondo del Cajón	6	507	406	2,5
19	P15708	Traseiro Gaveta	Rear Drawer	Traseo del Cajón	6	507	88	15
20	P15350	Fundo	Back Panel	Fondo	6	2220	424	2,5
21	P15506	Moldura Superior	Top Frame	Marco Superior	1	2577	75	15

Roup. Sofisticatto Canela Sensitive c| Linho

22	P15633	Porta	Door	Puerta	6	1276	540	12
23	P15634	Porta Puxador	Door Handle	Puerta Tirador	2	1276	540	12

Espelhos Sofisticatto Glass

24	35642	Espelho	Mirror	Espejo	2	1200	528	3
----	-------	---------	--------	--------	---	------	-----	---

Espelhos Sofisticatto Full Glass

24	35642	Espelho	Mirror	Espejo	4	1200	528	3
----	-------	---------	--------	--------	---	------	-----	---



Atenção com a cor do acabamento!
Em caso de assistência solicitar o código de acordo com a cor da peça.

Medidas em mm



Cod. Qnt.										
A 12	B 12	C 24	D 46	E 19	F 60	G 12	H 12	I 2		
J 140	K 32	L 5	M 38	N 210	O 4	P 7	Q 7	R 4		
S 1	T 1	U 3	V 38	W 2	X 12	Y 6	Z 2	AA 6		
AB 6	AC 3	AD 2	AE 4	AF 4	AG 4	AH 24	AI 4	AJ 4		
Kit Sistema Correr cod. 35766										
AK 4	AL 12	AM 24	AN 1	AO 12						

Roupeiro Sofisticatto Glass 2 Portas | Wardrobe Sofisticatto Glass 2 Doors | Ropero Sofisticatto Glass 2 Puertas

1º Passo / Step / Paso

Inicie a montagem da base, fixando as Divisões Pé (15) com Parafusos (D). Logo fixar Traseiro Pé (13) e Frente Pé (14) com Cantoneira (M) e Parafusos (N) /
 Start the base assembly, securing the Divisions Foot (15) with Screws (D). Logo fastening Rear Foot (13) and Front Foot (14) with Angle (M) and Screws (N) /
 Inicie el montaje de la base, fijando las Divisiones Pie (15) con Tornillos (D). Logo fijar Trasero Pie (13) y Frente Pe (14) con Cantonera (M) y Tornillos (N).

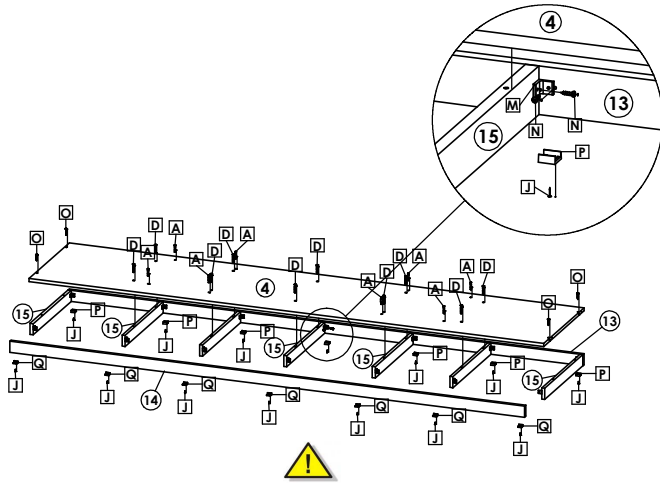

A Frente Pé (14) é alinhada pela frente da borda do tampo inferior (4). Utilizar Sapata L (Q) na Frente Pé (14) e Sapata Plástica (P) no Traseiro Pé (13).

2º Passo / Step / Paso

Já com a base montada, fixe as Divisões (4), com Parafuso (A) e Tambor (C). Em seguida fixar as Laterais (1, 2) e Tapos (9), com Parafusos (D) e (A) /
 Already with the base assembled, fix Divisions (4), with Screw (A) and Drum (C). Then fix the Sides (1, 2) e Tops (9), with Screws (D) and (A) /
 Con la base montada, fije las Divisiones (4), con Tornillo (A) y Tambor (C). A continuación fijar las Laterales (1, 2) y Tapas (9), con Tornillos (D) y (A).

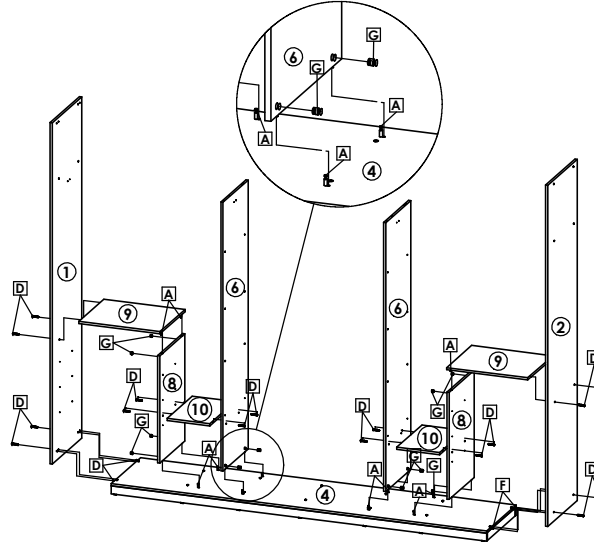

3º Passo / Step / Paso

Fixar a Divisão Maleiro (7), no Tampo (5), com Parafuso (D) e Cavilha (I). Isso deve ser feito antes de fixar o Tampo (5), nas Laterais (1, 2) e Divisão (6) /
 Secure Maleus Division (7) on Plate (5), with Screw (D) and Bolt (I). This should be done before securing Table (5), Sides (1, 2) and Divisions (3) /
 Fijar la División Maleiro (4), en el Tablero (5), con Tornillo (D) y Cuchillo (I). Esto debe hacerse antes de fijar el Tablero (5), en las Laterales (1, 2) y Divisiones (3).

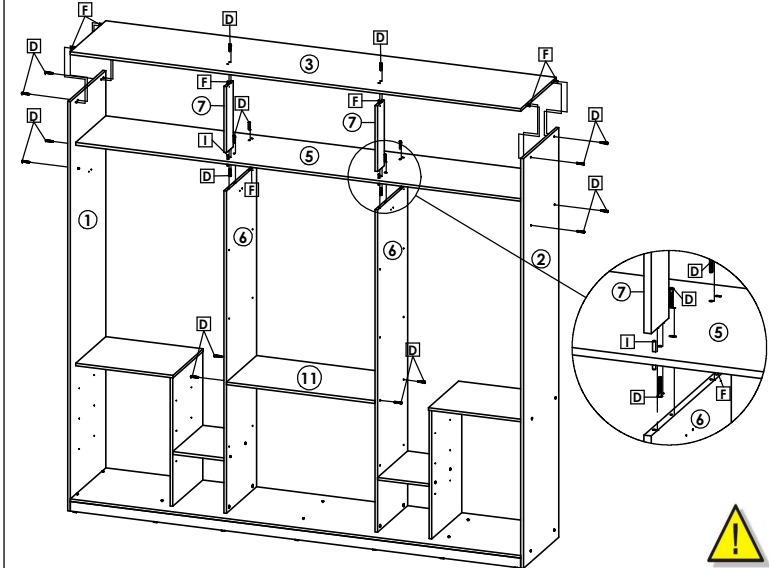

4º Passo / Step / Paso

Fixar os Fundos (20), com Pregos (J) e Presilha (K). Logo unir os Fundos (20), com Prerfis União (AC) e (AD) /
 Fix Backgrounds (20), with Nails (J) and Nail (K). Then merge Backgrounds (20), with Prerfis União (AC) and (AD) /
 Fijar los Fondos (20), con Clavos (J) y Presilla (K). Luego unir los Fondos (20), con Prerfis Unión (AC) y (AD).

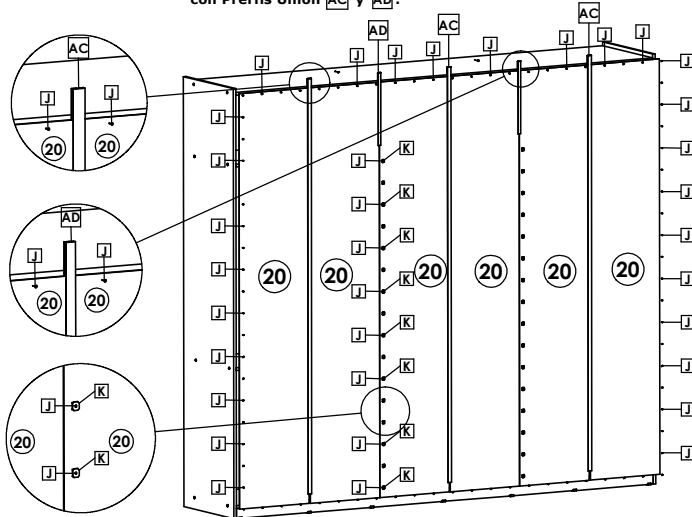

5º Passo / Step / Paso

Fixar Moldura (21), com Parafuso (N) e Cantoneira (L). Logo fixar o Perfil E (T), com Parafuso (E) /
 Attach Frame (21), with Screw (N) and Angle (L). Then secure the Profile E (T), with Screw (E) /
 Fijar Marco (21), con Tornillo (N) y Cantonera (L). Luego fijar el Perfil E (T), con Tornillo (E).

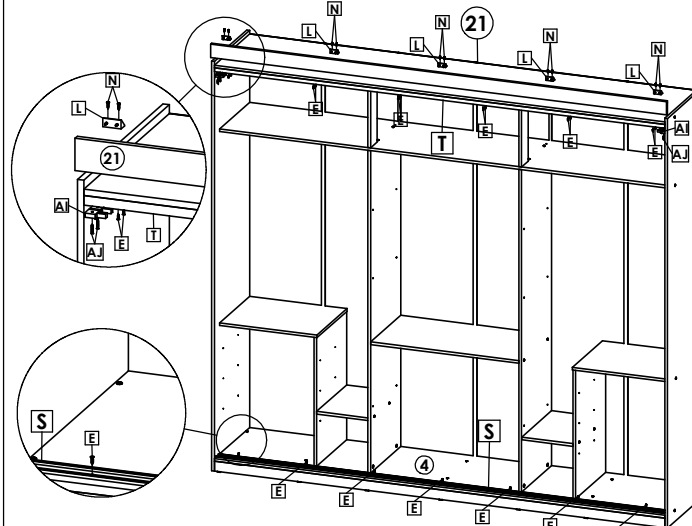

Fixar Trilho Inferior (S) com Parafuso (E), à 25mm da borda do Tampo Inferior (4) /
 Attach Lower Rail (S) with Screw (E), 25mm from bottom edge (4) /
 Fijar Carril Inferior (S) con Tornillo (E), a 25mm del borde del Tablero Inferior (4).

6º Passo / Step / Paso

Fixar corredeiras (AA) nas Laterais (1, 2) e Divisões (8), com Parafusos (C) /
 Attach slides (AA) to the sides (1, 2) and Divisions (8), with screws (C) /
 Corrigir Corretoras nas Nascentes (1, 2) e Divisões (8), com Parafusos (C).

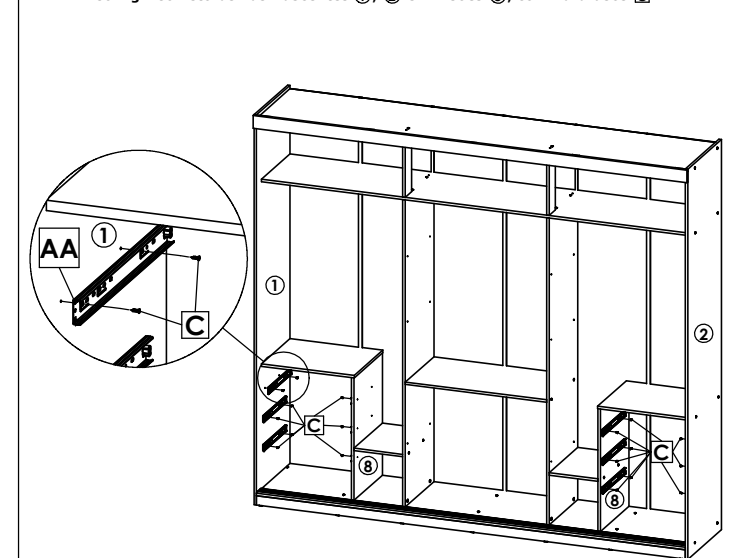

Roupeiro Sofisticatto Glass 2 Portas | Wardrobe Sofisticatto Glass 2 Doors | Ropero Sofisticatto Glass 2 Puertas

7º Passo / Step / Paso

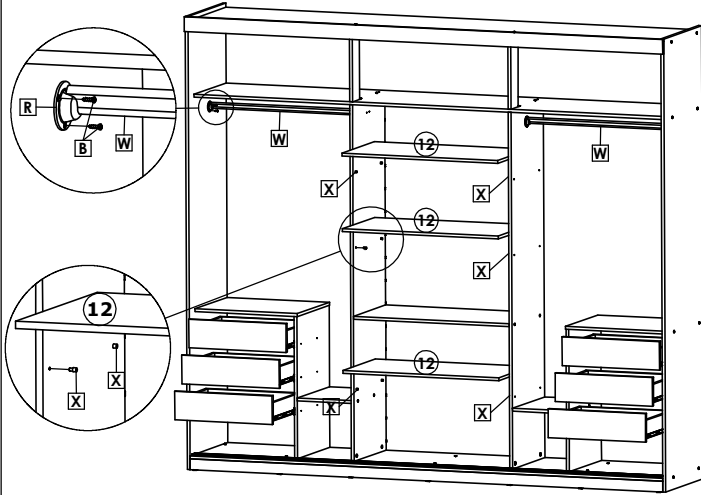

Colocação das Gavetas e Prateleiras / Placement of Drawers and Shelves / Colocação das Gavetas e Prateleiras.

Peso Suportado / Weight supported / peso que soporta.

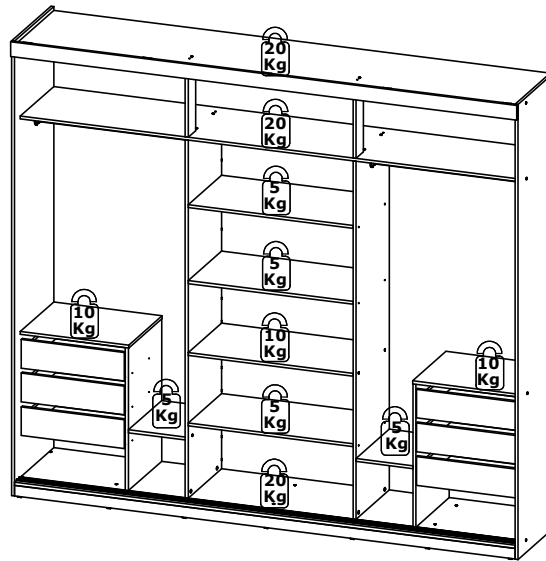

Peso Suportado por Gaveta / Weight Supported by Drawer / Peso suportado por Cajón.

Montagem Portas | Doors Assembly | Montaje Puertas.

AS PORTAS DEVEM SER MANUSIADAS POR DOIS MONTADORES!!! THE DOORS MUST BE HANDLED BY TWO MOUNTAINS !!! LAS PUERTAS DEBEN SER MANUSIADAS POR DOS MONTADORES !!!

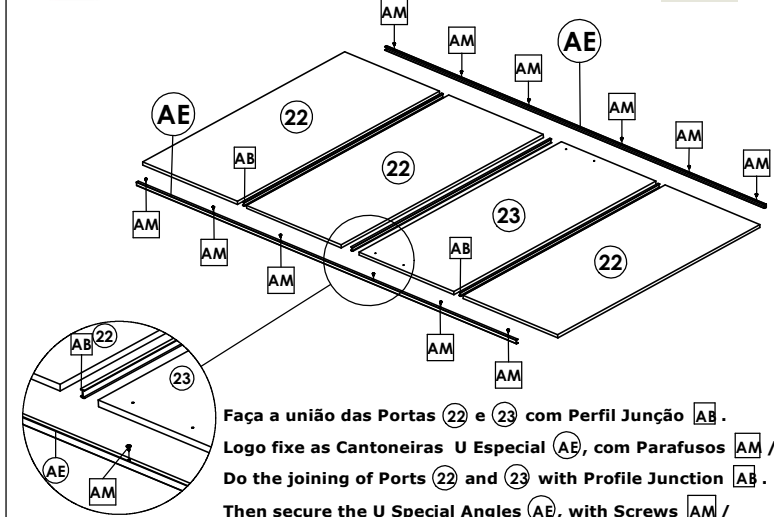

Faça a união das Portas 22 e 23 com Perfil Junção AB. Logo fixe as Cantoneiras U Especial AE, com Parafusos AM / Do the joining of Ports 22 and 23 with Profile Junction AB. Then secure the U Special Angles AE, with Screws AM / Haga la unión de las puertas 22 y 23 con perfil de unión AB. Luego fije las Cantoneiras U Especial AE, con Tornillos AM.

Montagem Portas | Doors Assembly | Montaje Puertas.



AS PORTAS DEVEM SER MANUSIADAS POR DOIS MONTADORES!!! THE DOORS MUST BE HANDLED BY TWO MOUNTAINS !!! LAS PUERTAS DEBEN SER MANUSIADAS POR DOS MONTADORES !!!

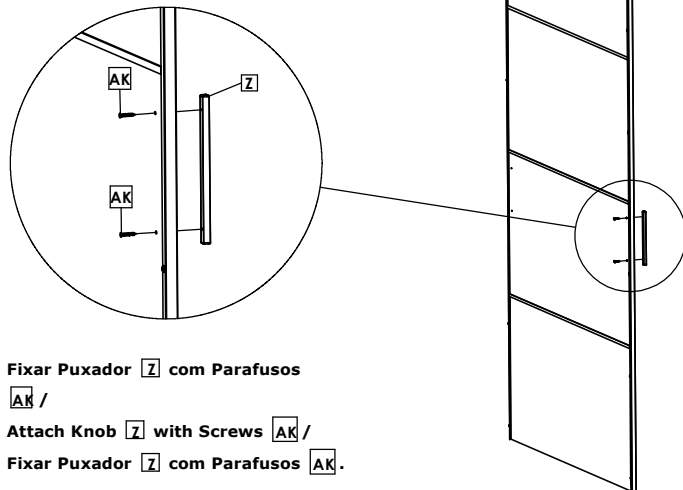

Fixar Puxador Z com Parafusos AK / Attach Knob Z with Screws AK / Fixar Puxador Z com Parafusos AK.

Montagem Portas | Doors Assembly | Montaje Puertas.



AS PORTAS DEVEM SER MANUSIADAS POR DOIS MONTADORES!!! THE DOORS MUST BE HANDLED BY TWO MOUNTAINS !!! LAS PUERTAS DEBEN SER MANUSIADAS POR DOS MONTADORES !!!

Iniciar a montagem dos Guias Superiores AF, posicionando-os à 30mm da Cantoneira U AE, fixando-os com Parafusos AJ /

Start montagem two Superior Guides AF, Positioning to 30mm from Cantoneira U AE, fixando-os com Parafusos AJ /

Iniciar a montagem dos Guias Superiores AF, posicionando-os à 30mm da Cantoneira U AE, fixando-os com Parafusos AJ.

Posicionar o Rodízio Inferior AG à 32mm da Cantoneira U AE /

Position the Rod Less AG than 32mm from the U-bracket AE /

Posicionar el Rodamiento Inferior AG a la 32mm de la Cantoneira U AE.

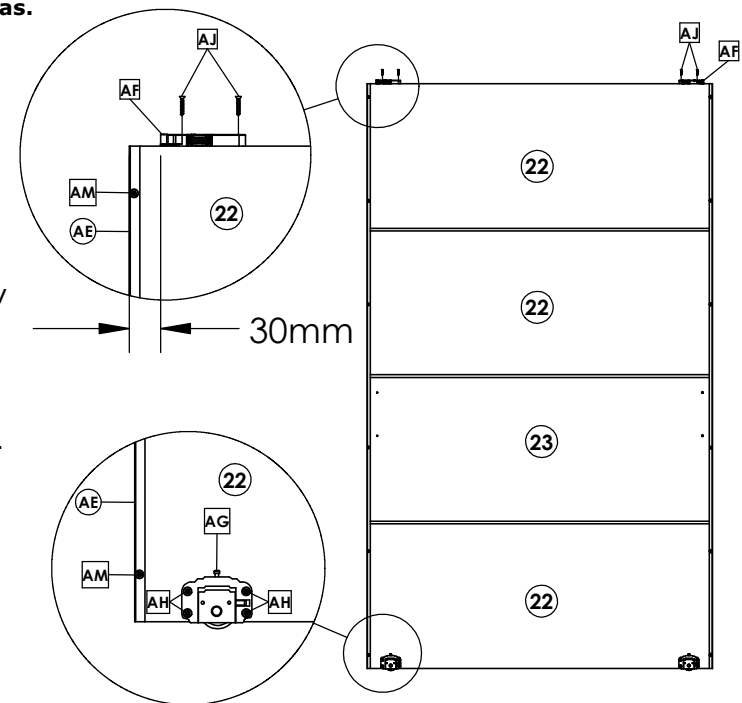

Roupeiro Sofisticatto Glass 2 Portas | Wardrobe Sofisticatto Glass 2 Doors | Ropero Sofisticatto Glass 2 Puertas

Inicie a montagem posicionando os Espelhos (24),
 á 1mm da Cantoneira U (AE) e dos Perfis Junção (AB). Logo fixe os Espelhos (24),
 com Parafusos (AP) e Suporte Vidro Pino (AQ) /

Start the assembly by positioning the Mirrors (24),
 1mm from the U (AE) Angle and the Junction Profiles (AB).
 Then fasten the Mirrors (24), with Screws (AP) and Support Glass Pin (AQ) /

Inicie el montaje colocando los espejos (24),
 a 1mm de la cantonera U (AE) y de los perfiles de la unión (AB).
 Luego fije los espejos (24), con los tornillos (AP) y el soporte de cristal Pino (AQ).

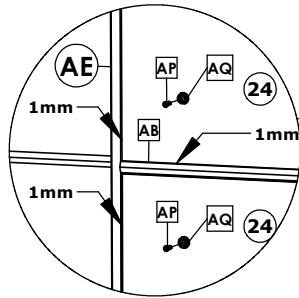
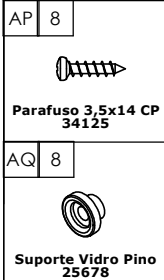

Sofisticatto Glass

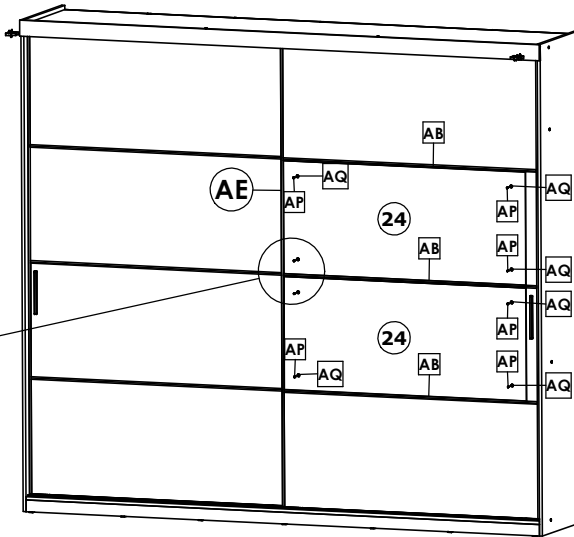

Sofisticatto Full Glass

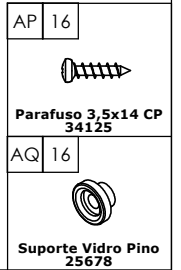
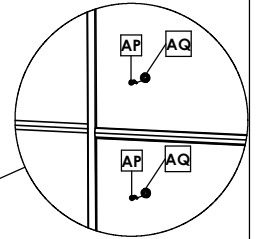
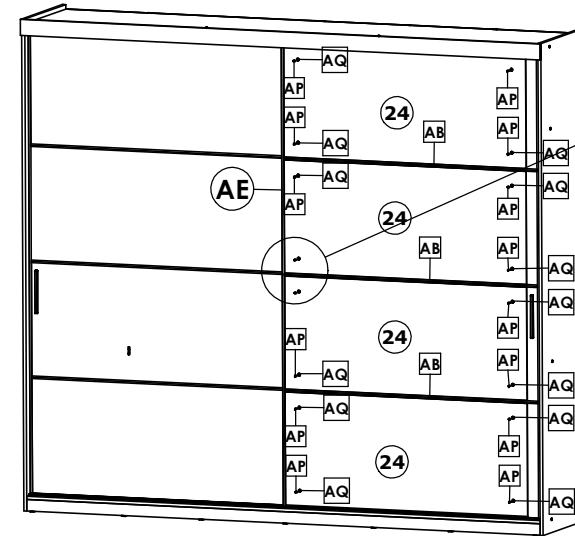

Produto Montado/ Product Mounted / Producto Montado.

Sofisticatto Glass



Sofisticatto Full Glass

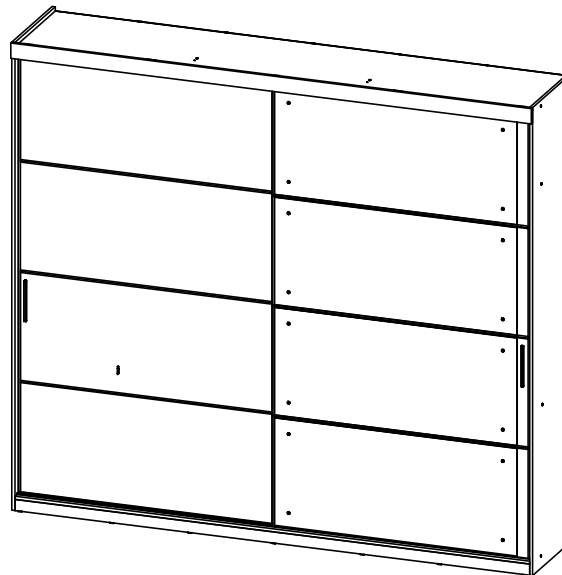

Sofisticatto

