

HENN

Ind. e Com. de Móveis Henn
Mondai - SC - Brasil

+55 49 3674.3500

@moveishenn
www.henn.com.br

INSTRUÇÕES DE MONTAGEM

INSTRUCCIONES DE MONTAJE
ASSEMBLY INSTRUCTIONS

Roupeiro Mango 06 Portas | Armario Mango 06 Puertas | Wardrobe Mango 06 doors

c D219-23 Duna

c D219-108 Duna/Off White

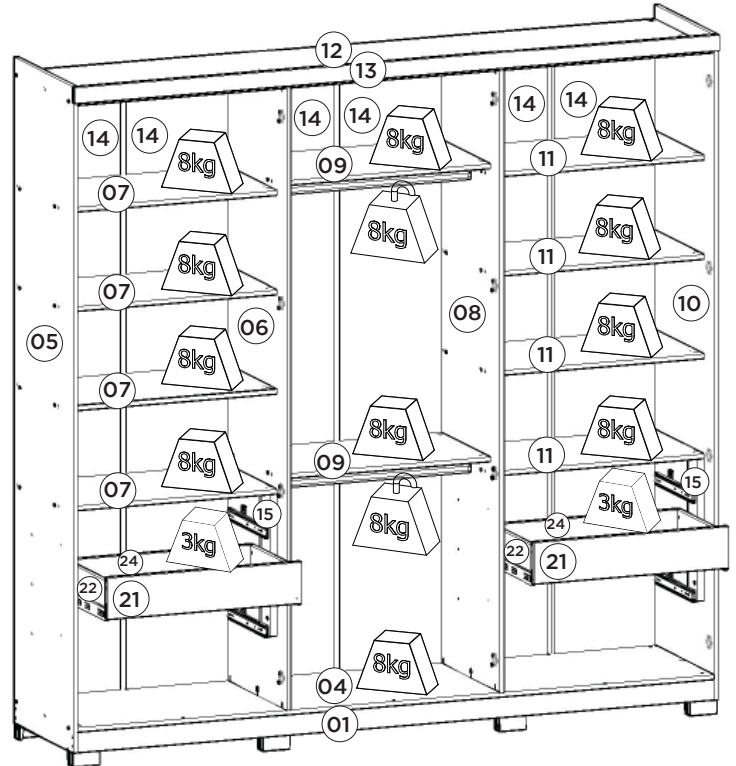
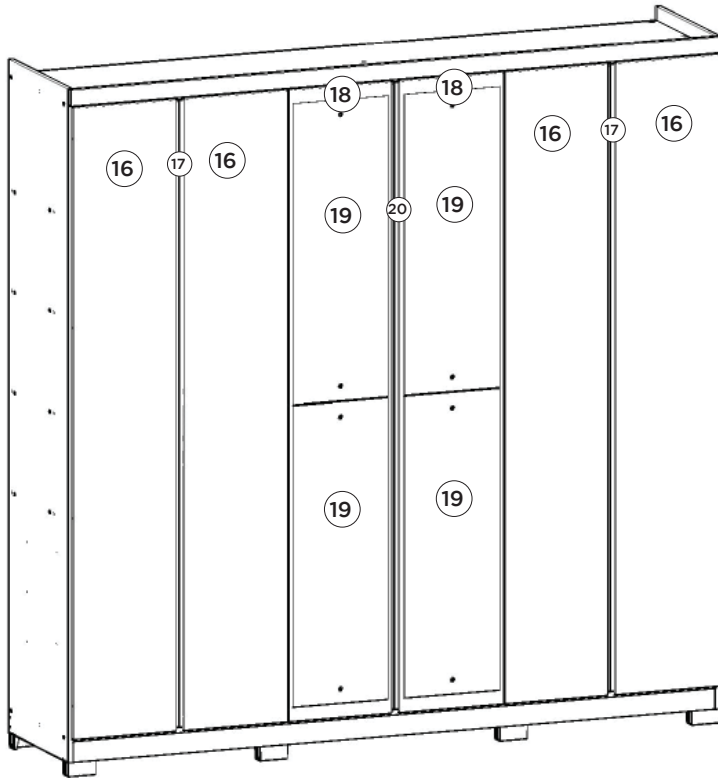

Pesos máximos recomendados com carga distribuída
Peso máximo recomendado con la carga distribuida
Recommended maximum weights with evenly distributed.

Requisitos para montagem Requisitor para la montaje Assembly Requirements

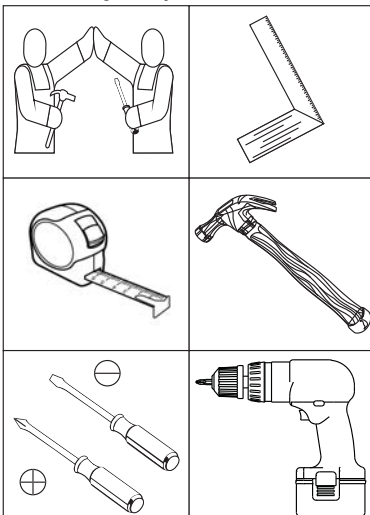

Imagens meramente ilustrativas
Imágenes meramente ilustrativas
Images for illustration only

AVISO

Para limpeza de seu móvel, use uma flanela seca ou umedecida, e não utilize produtos químicos que possam danificar seu produto.

SISTEMA DE MONTAGEM

O sistema de montagem dos produtos, funciona de acordo com a ordem crescente dos números indicados no desenho. Ex: 01, 02, 03, 04... até a conclusão da montagem.

ADVERTENCIA

Para limpieza de su móvil, use una flanela seca o húmeda, y no utilice productos químicos que puedan dañar su producto.

SISTEMA DE MONTAJE

El sistema de montaje de los productos funciona de acuerdo con el orden creciente de los números indicados en el dibujo. Ej.: 01, 02, 03, 04... hasta la conclusión del montaje.

NOTICE

To clean your furniture, use a dry or wet cloth, and do not use chemicals that may damage your product.

ASSEMBLY SYSTEM

The products' assembly system works according to the increasing order of the indicated numbers. For example: 01, 02, 03, 04 ... to the end of the assembly.

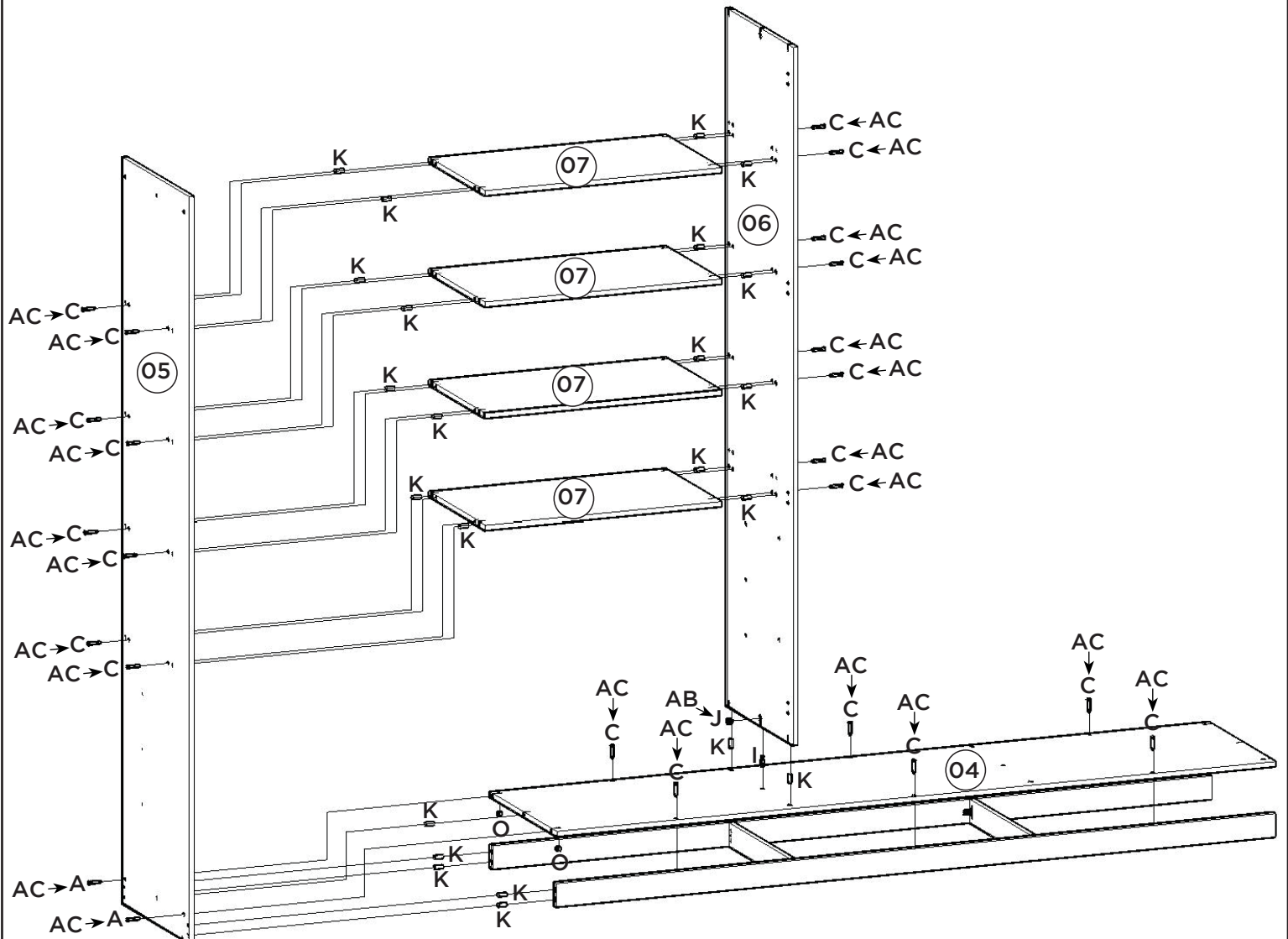
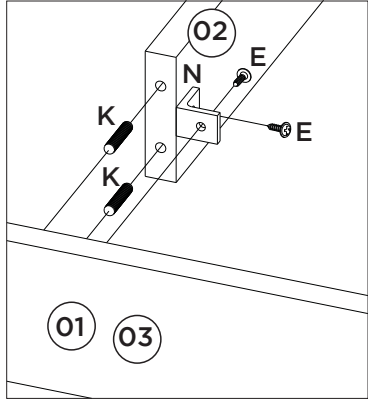
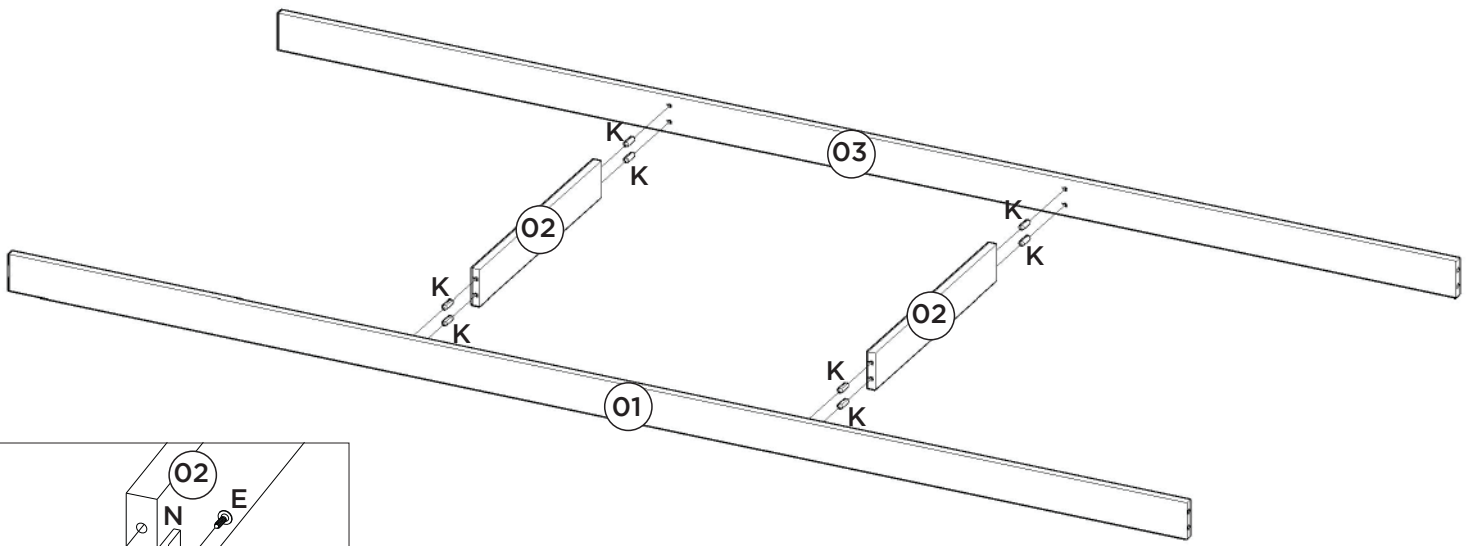

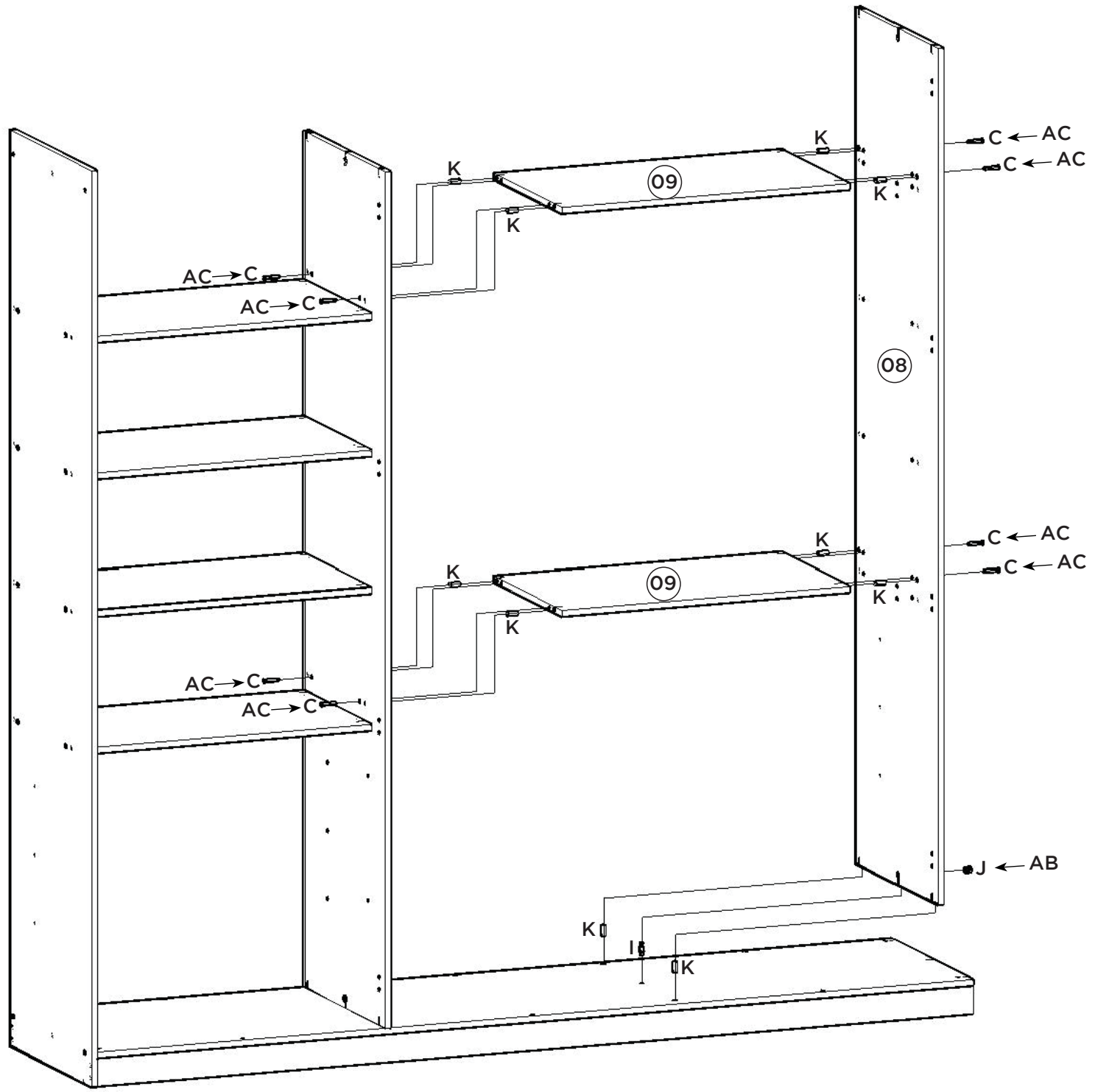

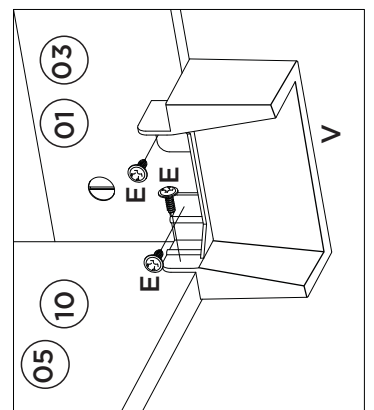
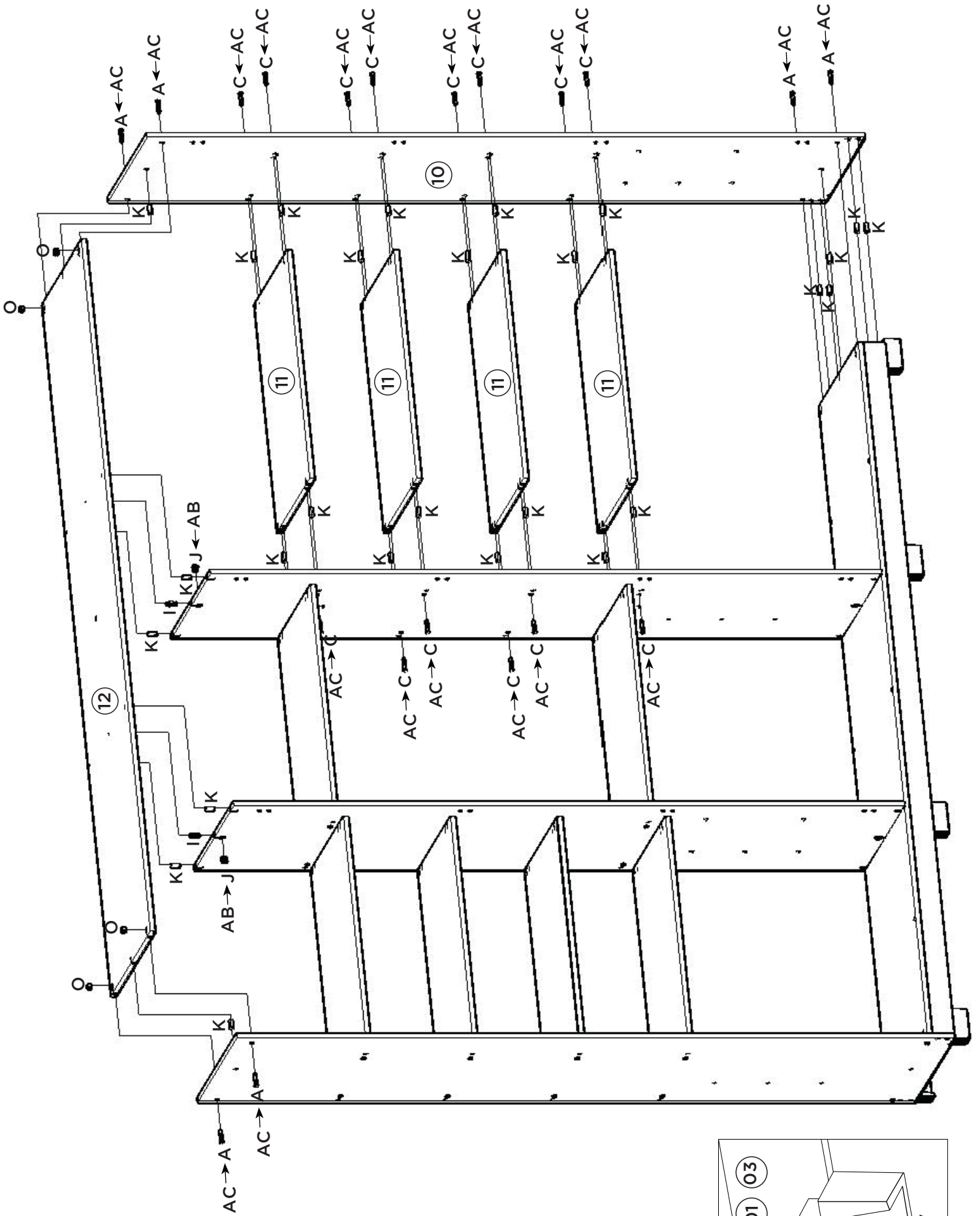

5°

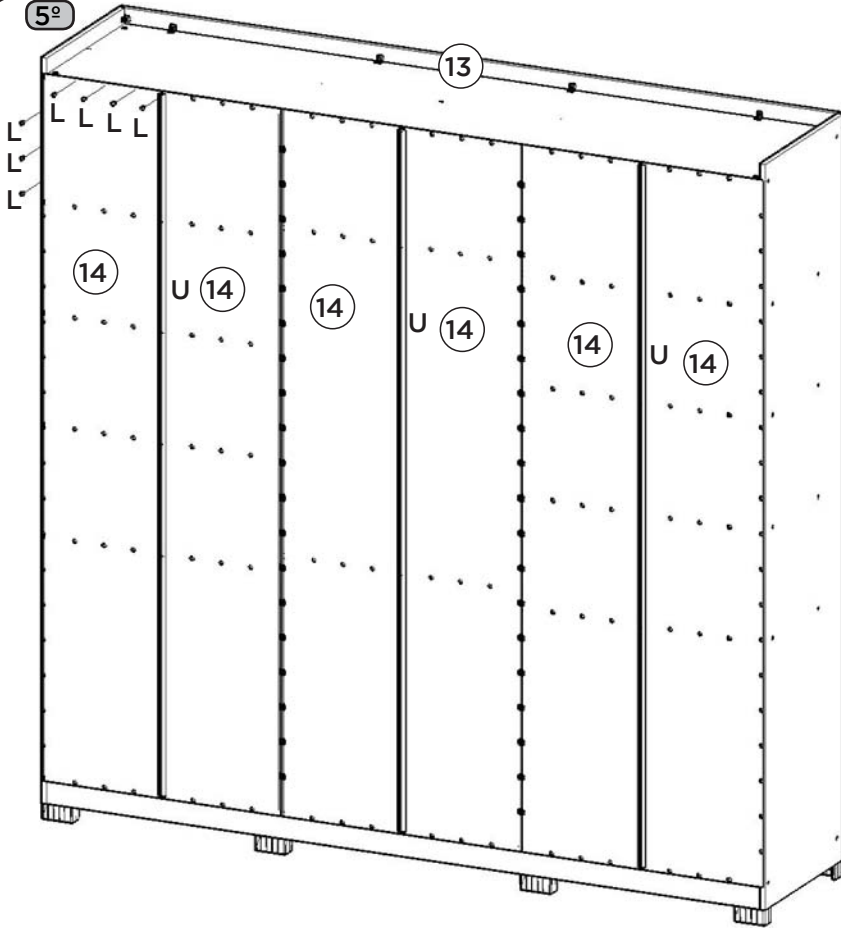

Colocar os pregos (L) a uma distância de 100mm de um para outro.

Coloque los clavos (L) a una distancia de 100 mm uno de otro.

Place the nails (L) at a distance of 100mm from one another.

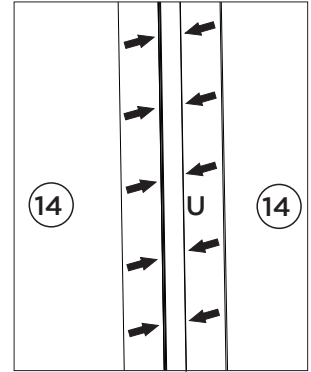
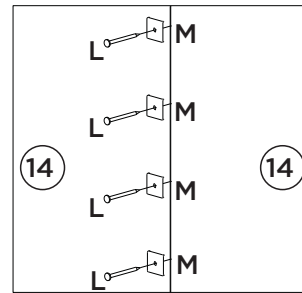
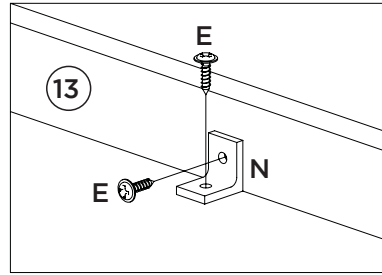

6°

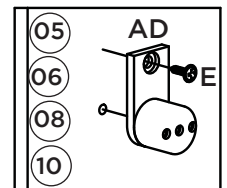
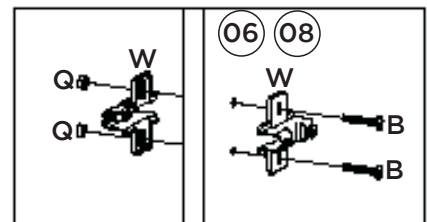
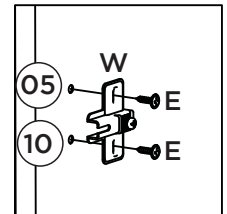
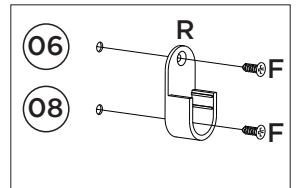
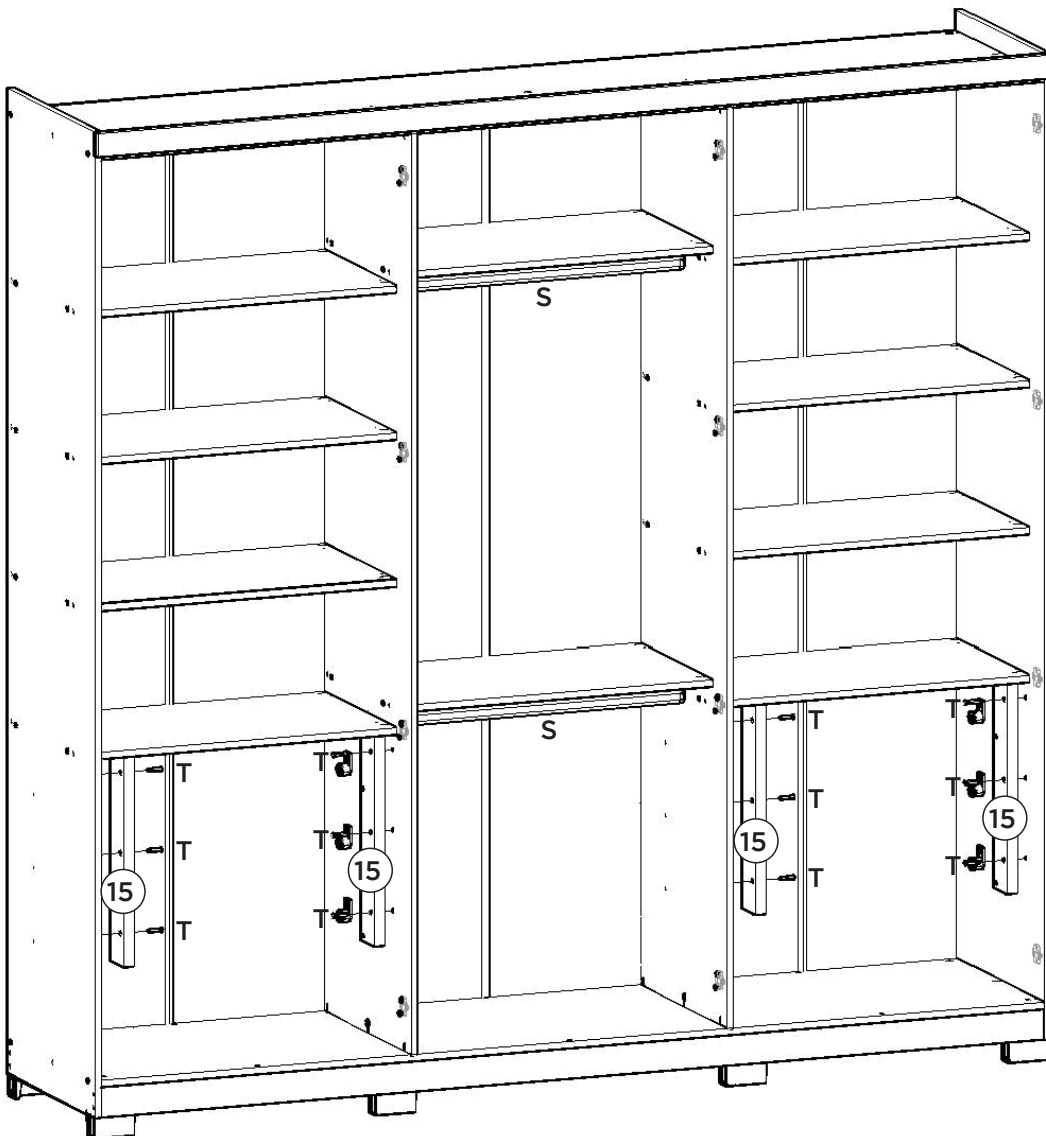

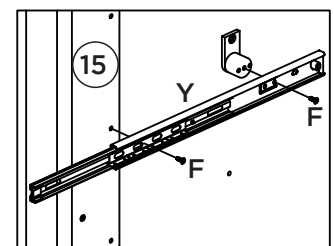
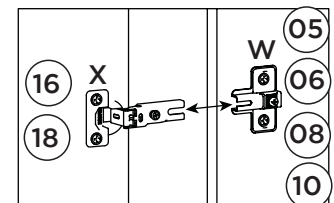
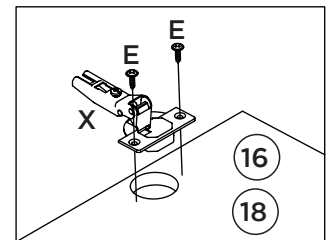
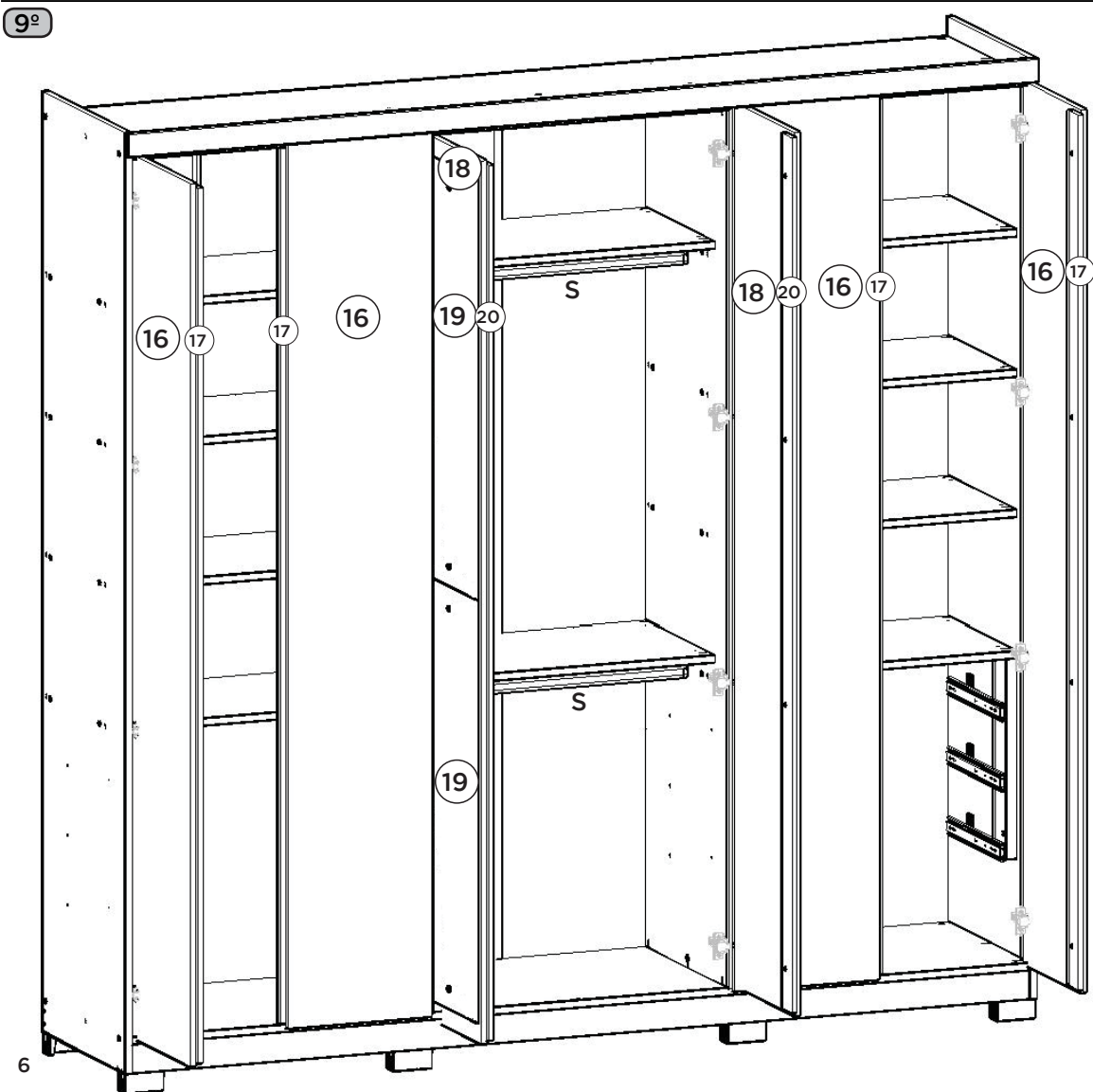
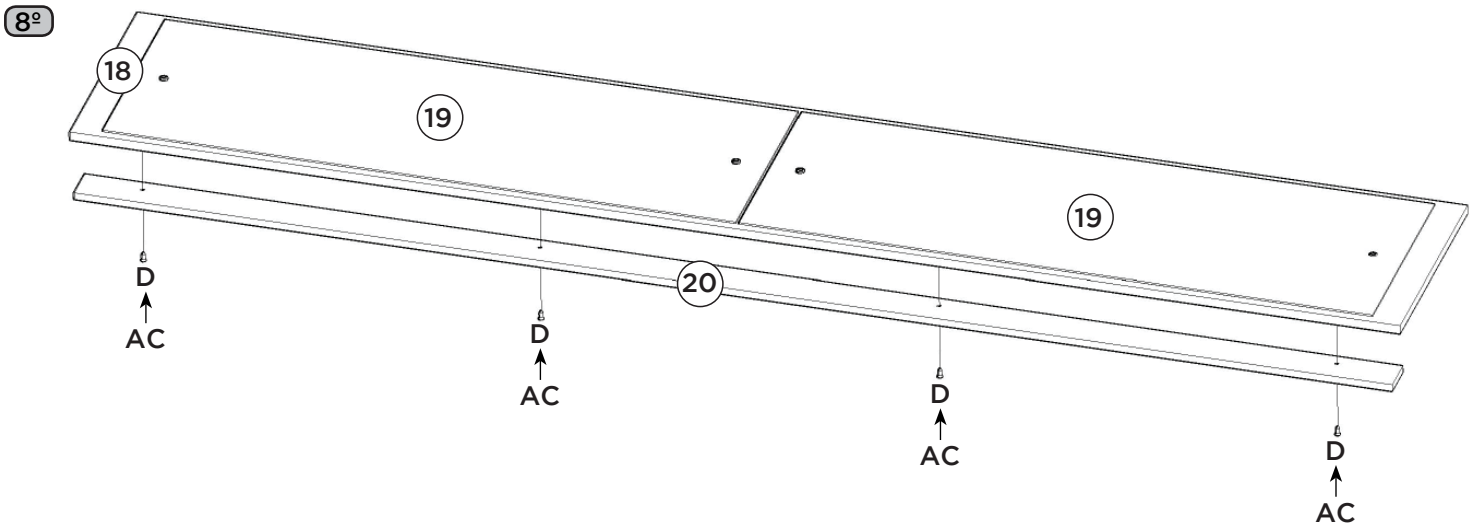
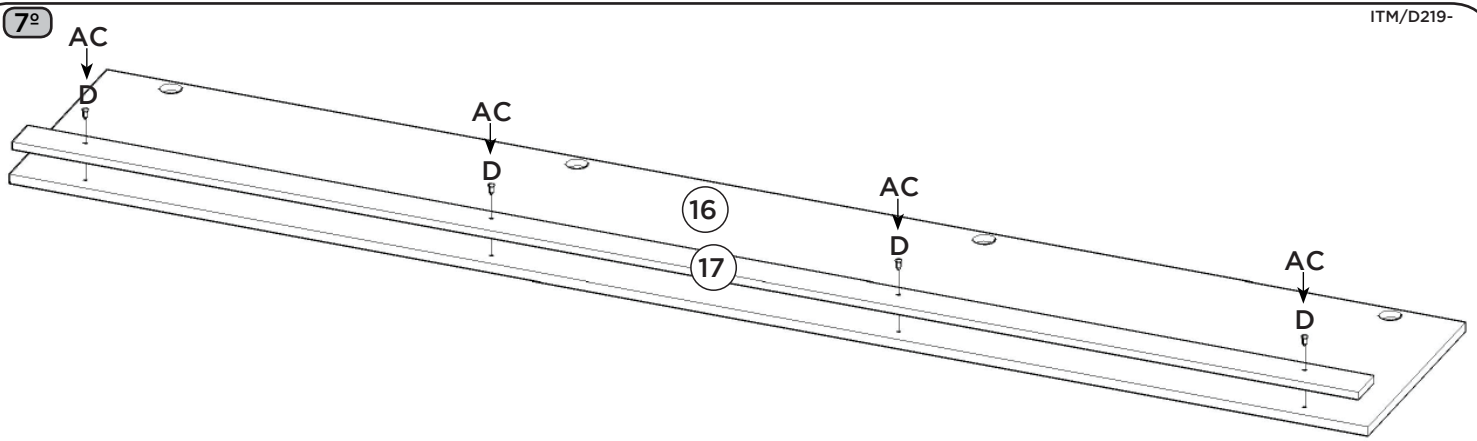

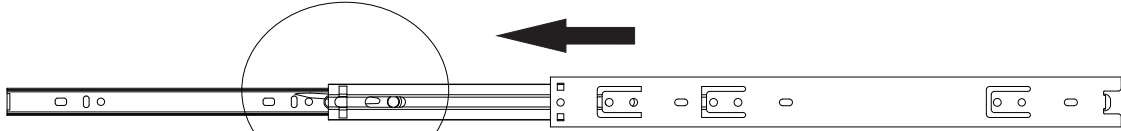

Para a desmontagem da correia siga a instrução ao lado.

Para el desmontaje seguimiento de diapositivas la instrucción siguiente a.

For the dismount of the sliding onem follows the instruction aside.

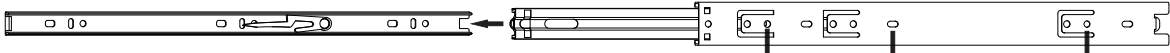
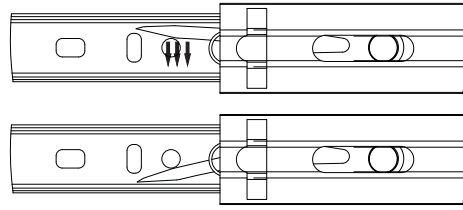



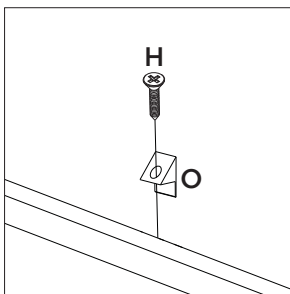
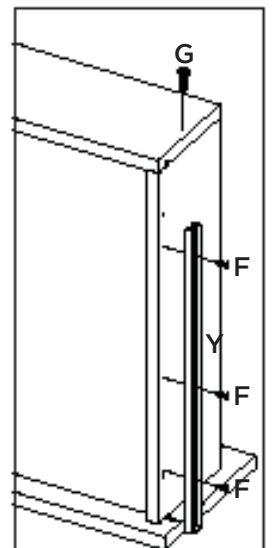
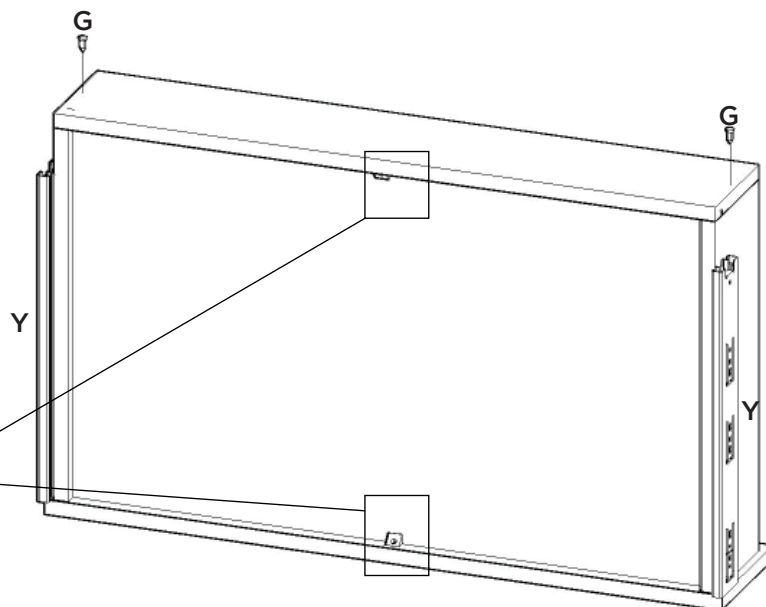
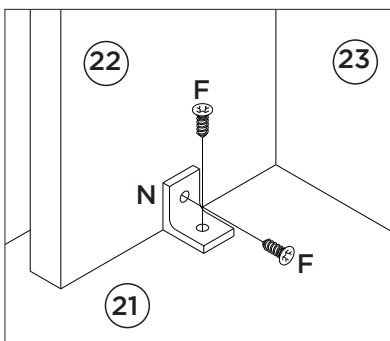
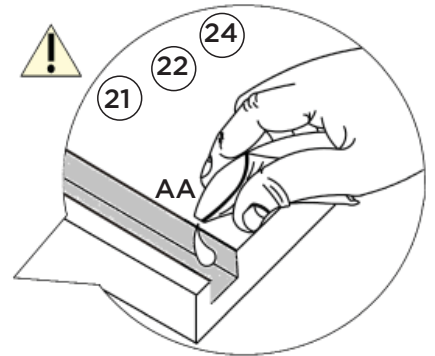
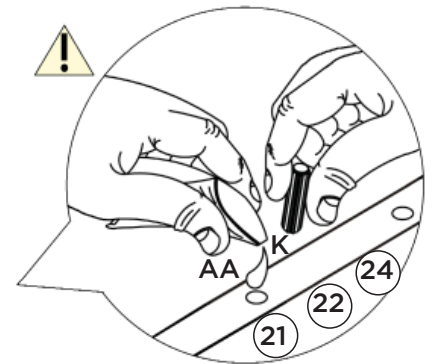
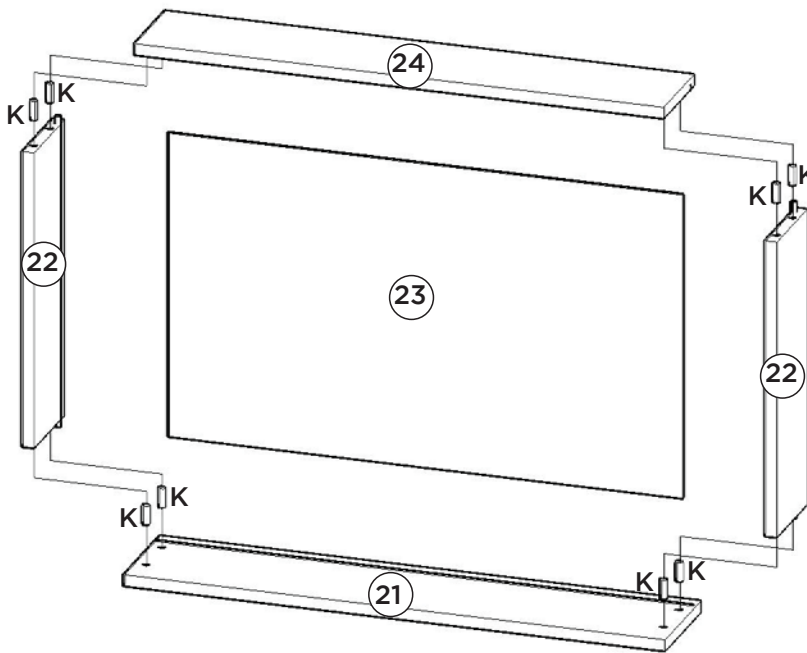







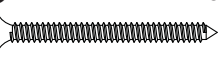
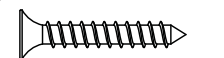

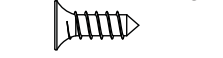





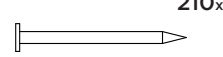
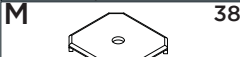

Fixar as correias nessas furações
 Fijar las diapositivas de estos agujeros
 Fix slides in these drillings

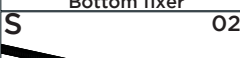
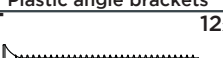
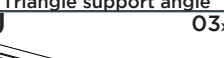

Item	Caixa Caja Box	Qtd Ctd Qty	Descrição Descripción Description	Medidas (mm) Dimensions (mm) Size (measurements) (mm)
01	2/6	01	Rodapé Frontal Rodapié Frontal Front baseboard	2373x73x15
02	1/6	02	Travessa do rodapé Carril pie Baseboard crosspiece	504x73x15
03	2/6	01	Rodapé Traseiro Rodapié trasero Rear baseboard	2373x73x15
04	2/6	01	Base Base Base	2373x540x15
05	1/6	01	Lateral esquerda Lateral izquierda Left side	2350x540x15
06	1/6	01	Divisão esquerda División de la izquierda Left Division	2197x540x15
07=09=11	4/6	04	Prateleira Estante Shelf	781x450x15
08	1/6	01	Divisão Direita División Derecha Right Division	2197x540x15
09=07=11	3/6	02	Prateleira Estante Shelf	781x450x15
10	1/6	01	Lateral direita Lateral derecha Right side	2350x540x15
11=07=09	4/6	04	Prateleira Estante Shelf	781x450x15
12	2/6	01	Tampo Tapa Top	2373x540x15
13	2/6	01	Chapéu Sombrero Hat	2401x55x15
14	5/6	06	Fundo Fondo Bottom	2227x398x3
15	2/6	04	Ripa lateral Ripa lateral Ripa side	502x80x25
16	6/6	04	Porta Puerta Door	2207x380x15
17=20	2/6	04	Travessa Frontal Travessa Frontal Front Tray	2187x60x12
18	5/6	02	Porta Central Espelho Puerta Central Espejo Central Mirror Door	2207x380x15
19	5/6	04	Espelho Espejo Mirror	1050x350x3
20=17	2/6	02	Travessa Frontal Travessa Frontal Front Tray	2187x60x12
21	3/6	06	Frente de gaveta Frente de cajón Front of drawer	723x145x15
22	3/6	12	Lado de gaveta Lado del cajón Side of drawer	400x122x15
23	3/6	06	Fundo de gaveta recortado Fondo del cajón recortado Cropped drawer bottom	687x411x3
24	3/6	06	Ripa de trás Malla detrás Rear lath	706x122x15

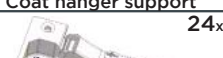
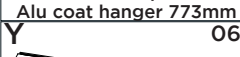
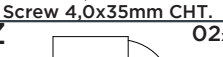
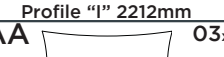
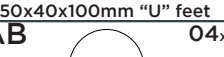
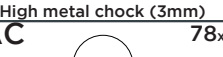
Ferragens | Herrajes | Hardware

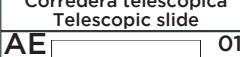
A  Parafuso 4,5x50mm CHT. Tornillo 4,5x50mm CHT. Screw 4,5x50mm CHT.	B  Parafuso 4,0x25mm FLA. Tornillo 4,0x25mm FLA. Screw 4,0x25mm FLA.	C  Parafuso 3,5x40mm CHT. Tornillo 3,5x40mm CHT. Screw 3,5x40mm CHT.	D  Parafuso 3,5x22mm CHT. Tornillo 3,5x22mm CHT. Screw 3,5x22mm CHT.	E  Parafuso 3,5x14mm FLA. Tornillo 3,5x14mm FLA. Screw 3,5x14mm FLA.	F  Parafuso 3,5x12mm CHT. Tornillo 3,5x12mm CHT. Screw 3,5x12mm CHT.
G  Parafuso 3,0x30mm CHT. Tornillo 3,0x30mm CHT. Screw 3,0x30mm CHT.	H  Parafuso 3,0x16mm CHT. Tornillo 3,0x16mm CHT. Screw 3,0x16mm CHT.	I  Parafuso minifix Tornillo minifix Minifix bolt	J  Tambor minifix Tambor minifix Minifix drum	K  Cavilha 8x25mm Cinta 8x25mm Dowel 8x25mm	L  Prego 10x10mm Clavo 10x10mm Nail 10x10mm
M  Fixador de fundos Fijador de fondos Bottom fixer	N  Cantoneira plástica Cantonera plástica Plastic angle brackets	O  Cantoneira suporte triangular Cantonera soporte triangular Triangle support angle	P  Porca cilíndrica Tuerca cilíndrica Cylindrical nut	Q  Porca Sextavada Tuerca Hexagonal Hexagon Nut	R  Suporte cabideiro Soporte de percha Coat hanger support
S  Cabideiro Alum. 773mm Alu 773mm percha Alu coat hanger 773mm	T  Parafuso 4,0x35mm CHT. Tornillo 4,0x35mm CHT. Screw 4,0x35mm CHT.	U  Perfil "I" 2212mm Perfil "I" 2212mm Profile "I" 2212mm	V  Pé "U" 50x40x100mm Pie "U" 50x40x100mm 50x40x100mm "U" feet	W  Calço metal Alto (3mm) Calzado metálico Alto (3mm) High metal chock (3mm)	X  Dobradiça metal 35mm Bisagra de metal 35mm 35mm metal hinge
Y  Corrediça telescópica Corredera telescópica Telescopic slide	Z  Giz de correção Tiza de corrección Chalk of correction	AA  Sachê de cola Bolsa de pegamento Glue bag	AB  Adesivo tapa parafuso 17mm Adhesivo tapón de tornillo 17mm Bolt cover adhesive 17mm	AC  Adesivo tapa parafuso 10mm Adhesivo tapón de tornillo 10mm Bolt cover adhesive 10mm	AD  Distanciador de corrediça Distanciador de deslizamiento Sliding spacer
AE  Etiqueta resinada Henn Etiqueta resinada Henn Henn resin label					