

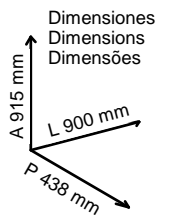

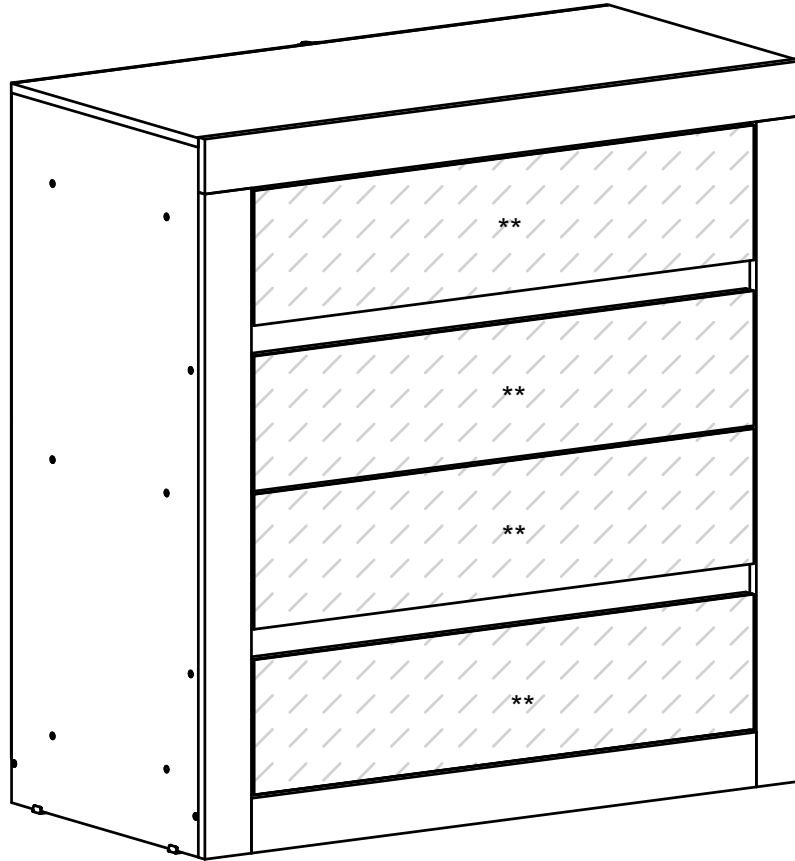











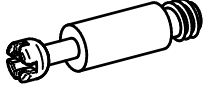



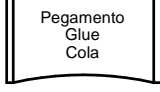

Ref. 838

Comoda / Chest of Drawers / Cômuda

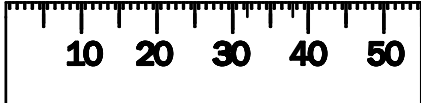

** Espejos Opcionales
 ** Mirrors Optional
 ** Espelhos Opcionais

(A)  Parafuso 3,5 x 14 11 un.	(B)  Parafuso 4 x 12 56 un.	(C)  Parafuso 4 x 20 8 un.	(D)  Parafuso 4 x 25 4 un.	(E)  Parafuso 4 x 30 16 un.	(F)  Parafuso 4 x 40 22 un.
(G)  4 un.	(H)  4 un.	(I)  30 un.	(J)  56 un.	(K)  6 x 30 28 un.	(L)  Pegamento Glue Cola 1 un.
(M)  16 un.	(N)  2 un.	(O)  8 un.	(P)  9 un.	(Q)  6 un.	(R)  2 un.
(S)  2 un.	(T)  1 un.	(U)  24 un.			

Herramientas
Tools
Ferramentas



120 min.



Personas Necessarias
People Required
Pessoas Necessárias

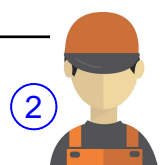

Consejos de Conservación

- No debe utilizarse en la limpieza, abrasivos como lana de acero, alcohol, vinagre, limón, o productos corrosivos que puedan rayar o quitar la película protectora en los muebles.
- Cuando la limpieza de muebles en general, napa y formica, deben utilizarse un paño ligeramente humedecido y jabón suave.
- Para mover el móvil, es importante que este se eleve desde el suelo, debido a que el arrastre puede causar daño estructural.
- No deje a su móvil en exposición a la intemperie.

Conservation Tips

- Do not use abrasive products to clean such as steel wool, alcohol, vinegar, lemon, scouring powder, or corrosive products which can scratch or peel off the protective film of the furniture.
- The best way to clean your furniture is to use a slightly moistened cloth with a mild soap.
- To move the furniture assembled, it is important that it is lifted off the ground, because the drag it can cause structural damage.
- Do not leave your furniture in weather exposure.

Dicas de Conservação

- Não utilizar na limpeza produtos abrasivos tais como: palha de aço, álcool, vinagre, limão, saponáceo, ou produtos corrosivos que possam riscar ou descolar a película protetora dos móveis.
- Na limpeza de móveis em geral, naps e fórmicas, deve ser utilizado um pano levemente umedecido e sabão neutro.
- Para a movimentação do móvel, é importante que este seja levantado do chão, pois ao arrastá-lo pode causar avarias estruturais.
- Não deixe o móvel em exposição a intempéries.

Certificado de Garantia

A garantia dos produtos fabricados pela Carraro, abrange eventuais defeitos/vícios de fabricação, no prazo estabelecido pelo Código de Defesa do Consumidor, em seu artigo 26,II, o qual prevê a garantia legal de 90 (noventa) dias.

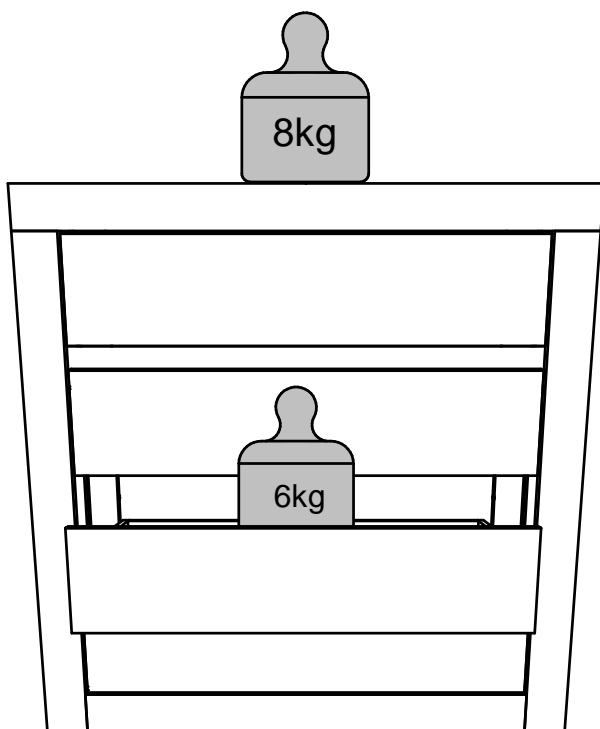

Peso por estante

Por favor, preste atención a los pesos máximos admitidos por cada compartimento del producto. Tenga cuidado de no exceder estos pesos, con el fin de garantizar la calidad y durabilidad del producto.

Es importante recordar que los pesos muestran en caso de ser distribuida en toda el área de la plataforma.

Weight per shelf

Please pay attention to the maximum weights supported by each compartment product. Be careful not to exceed these weights, in order to ensure the quality and durability of the product. It is important to remember also that the weights shown should be distributed throughout the area of the shelf.

Peso por Prateleira

Ao lado são demonstrados os pesos máximos suportados por cada compartimento do produto. Cuide para não exceder esses pesos, afim de garantir a qualidade e a durabilidade do mesmo. É importante lembrar também, que os pesos mostrados devem ser DISTRIBUÍDOS ao longo de toda a área da peça.

LISTA DE PIEZAS / LIST OF PARTS / RELAÇÃO DE PEÇAS

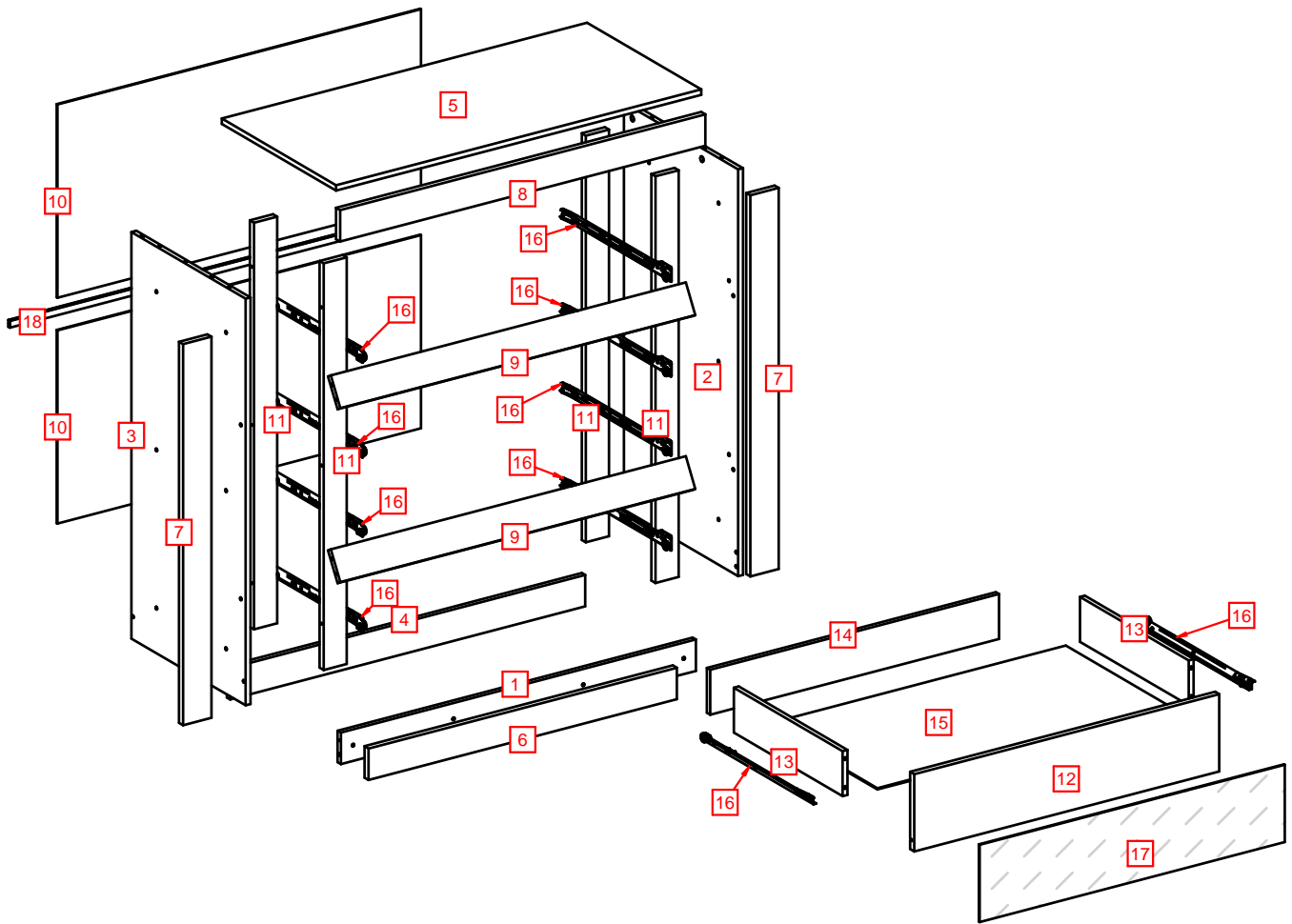

#	Qtde.	Espanhol	Inglês	Português	Dimensões	#	Qtde.	Espanhol	Inglês	Português	Dimensões
1	1	Zócalo Delantero	Front Baseboard	Rodapé Dianteiro	875 x 70 x 12	10	2	Costado	Back Panel	Costa	896 x 430 x 2,8
2	1	Lateral Derecha	Right Side Panel	Lateral Dereita	905 x 420 x 12	11	4	Espaciador de Cajones	Drawer Spacer	Afastador de Gaveta	905 x 57 x 15
3	1	Lateral Izquierda	Left Side Panel	Lateral Esquerda	905 x 420 x 12	12	4	Frente del Cajón	Drawer Front	Frente de Gaveta	752 x 172 x 15
4	1	Zócalo Trasero	Back Baseboard	Rodapé Traseiro	875 x 70 x 12	13	8	Lateral del Cajón	Drawer Side	Lateral de Gaveta	400 x 100 x 12
5	1	Tapa	Top	Tampo	900 x 420 x 12	14	4	Costa del Cajón	Drawer Back	Costa de Gaveta	712 x 100 x 12
6	1	Marco Inferior	Lower Frame	Moldura Inferior	760 x 70 x 15	15	4	Fondo del Cajón	Drawer Bottom	Fundo de Gaveta	736 x 405 x 2,8
7	2	Marco Lateral	Side Frame	Moldura Lateral	848 x 70 x 15	16	4	Corredera Metalica	Metalic Runner	Corredixa Metálica	400mm
8	1	Marco Superior	Upper Frame	Moldura Superior	900 x 70 x 15	17	4	Espejo	Mirror	Espelho	752 x 172 x 3
9	2	Marco Cajones	Angle Frame	Vista Gavetas	875 x 70 x 12	18	1	Perfil	"I" Profile	Perfil I	874 x 15 x 6

1

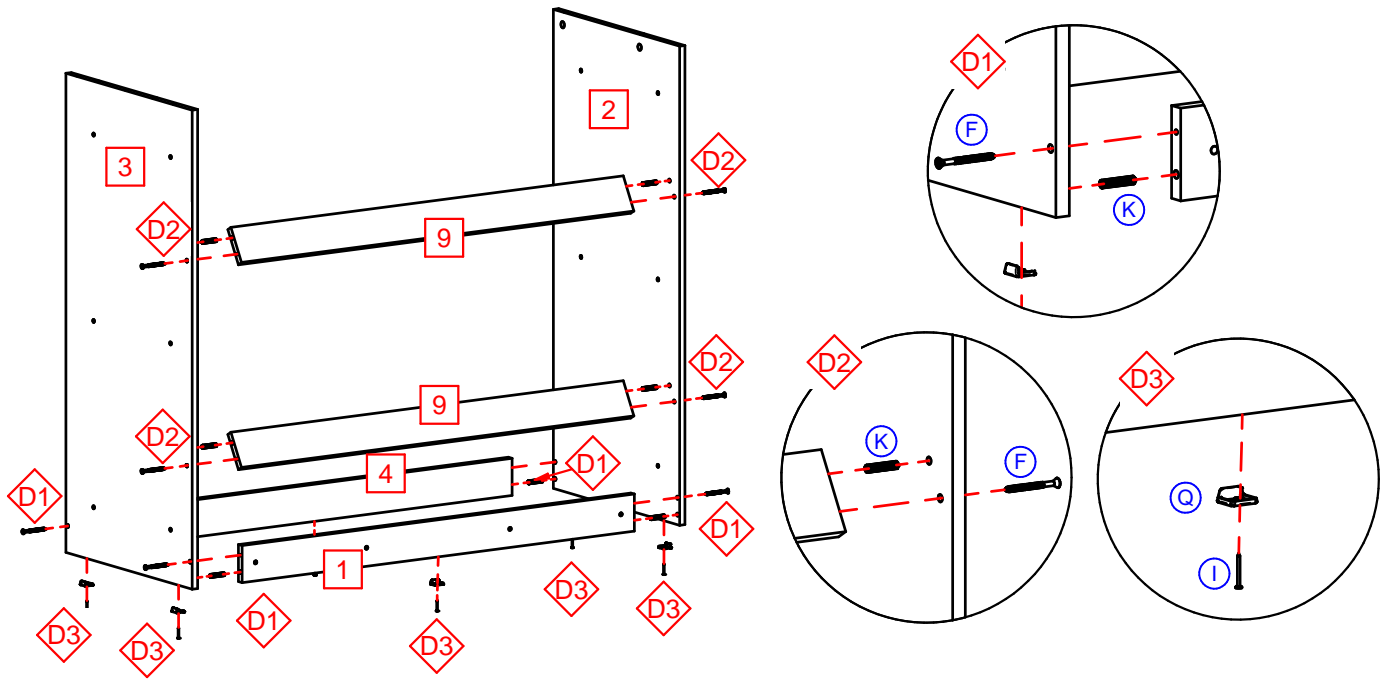

2

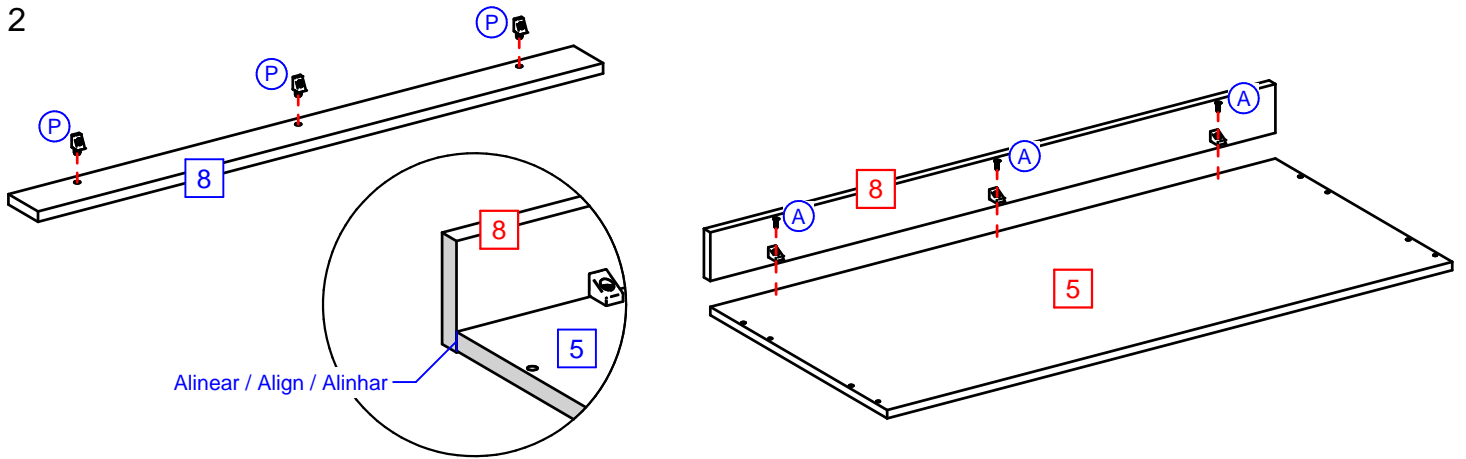

3

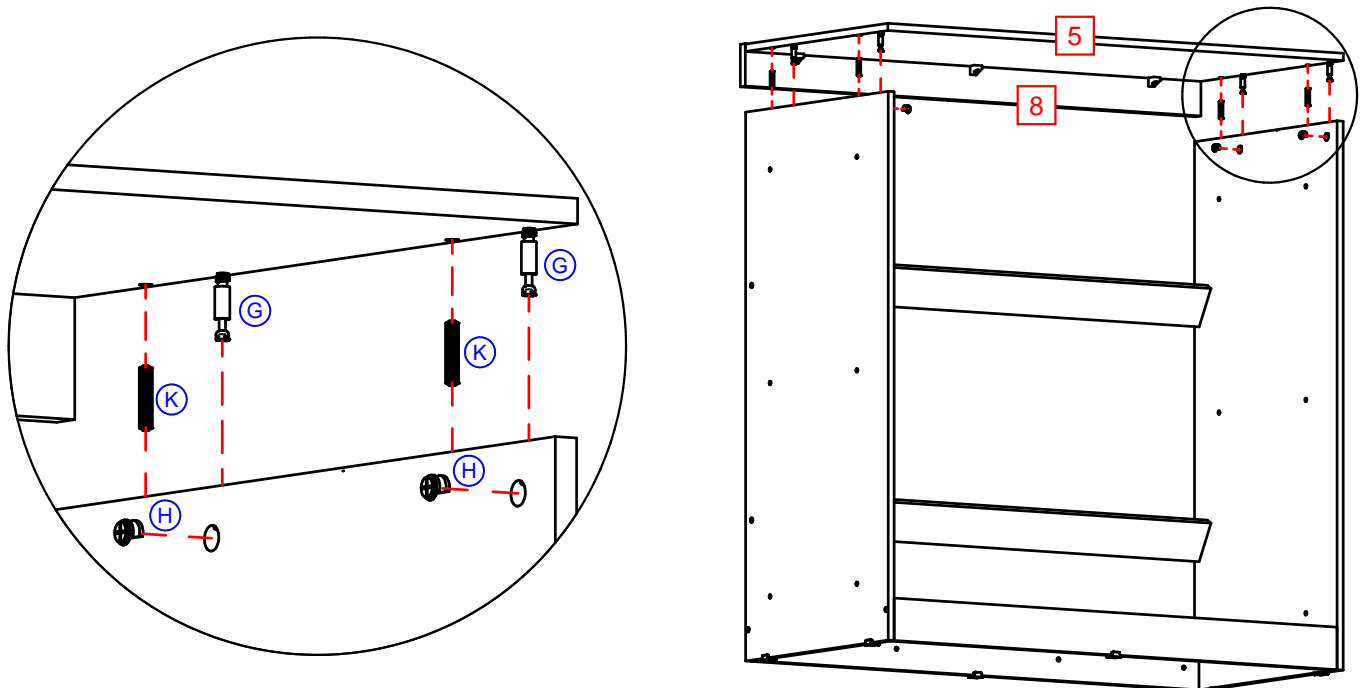

4

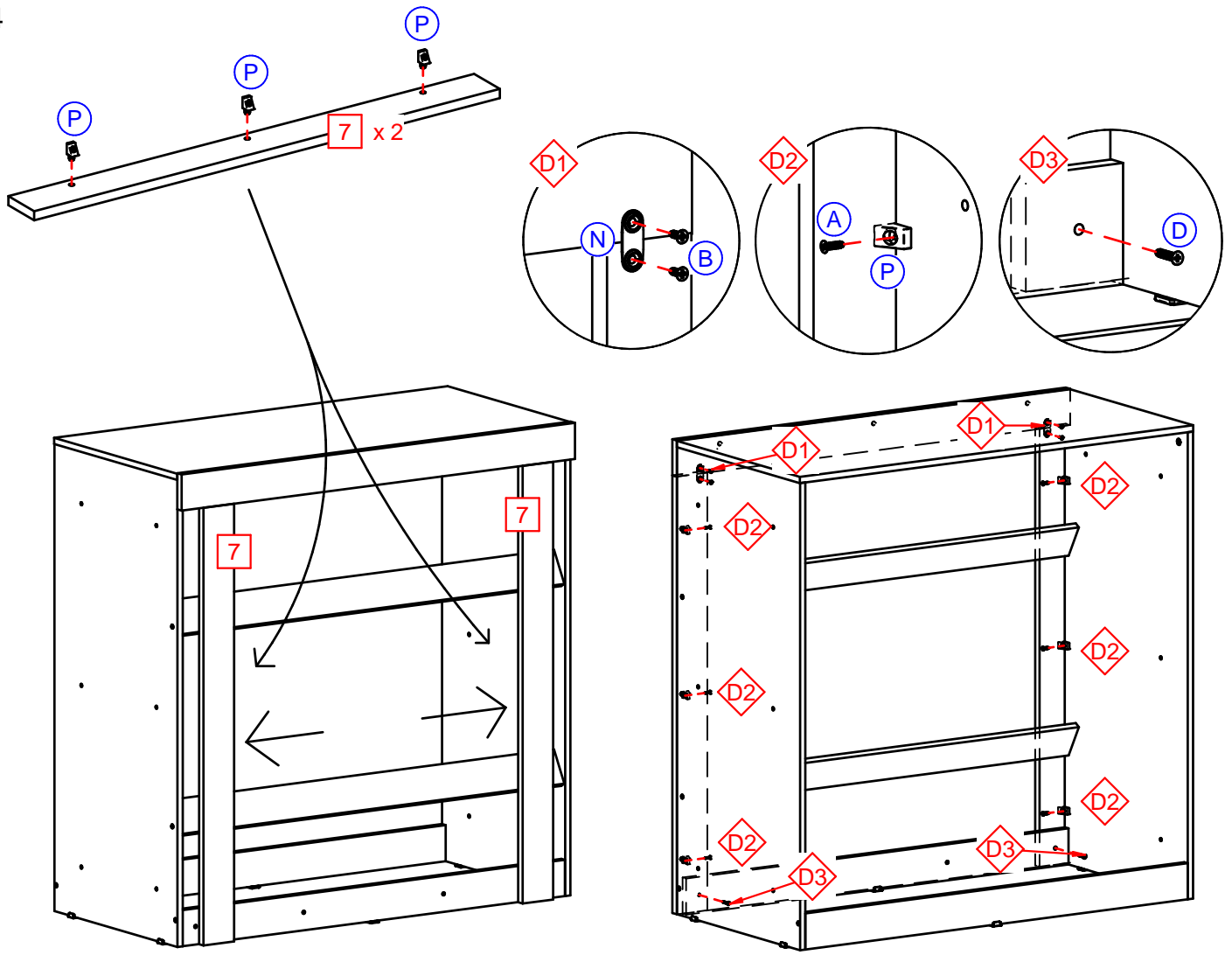

5

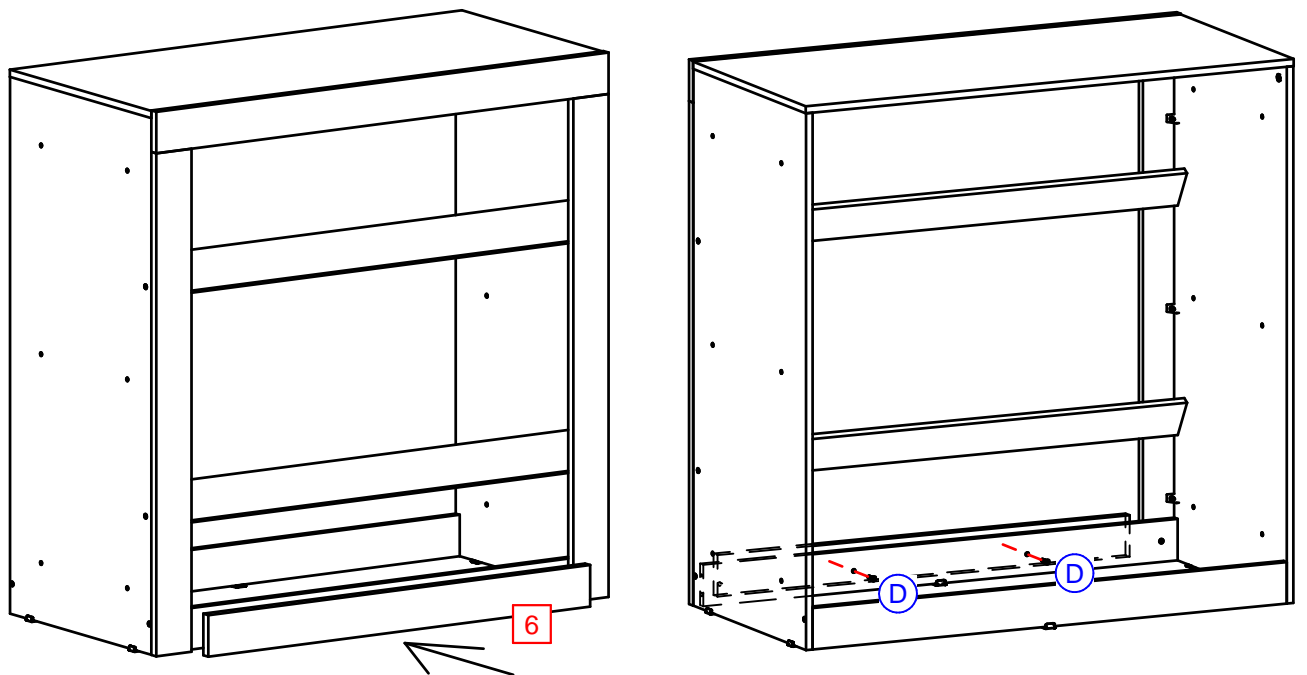

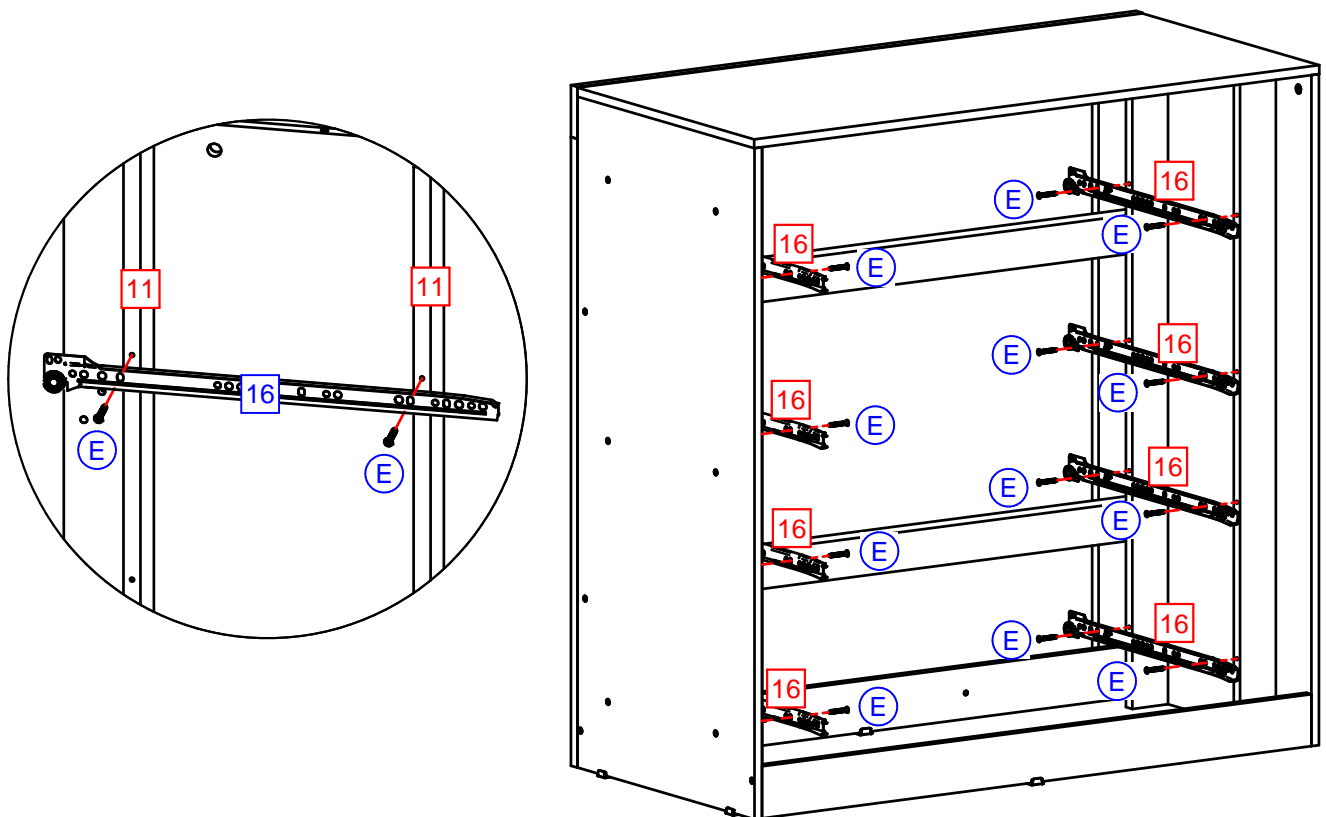
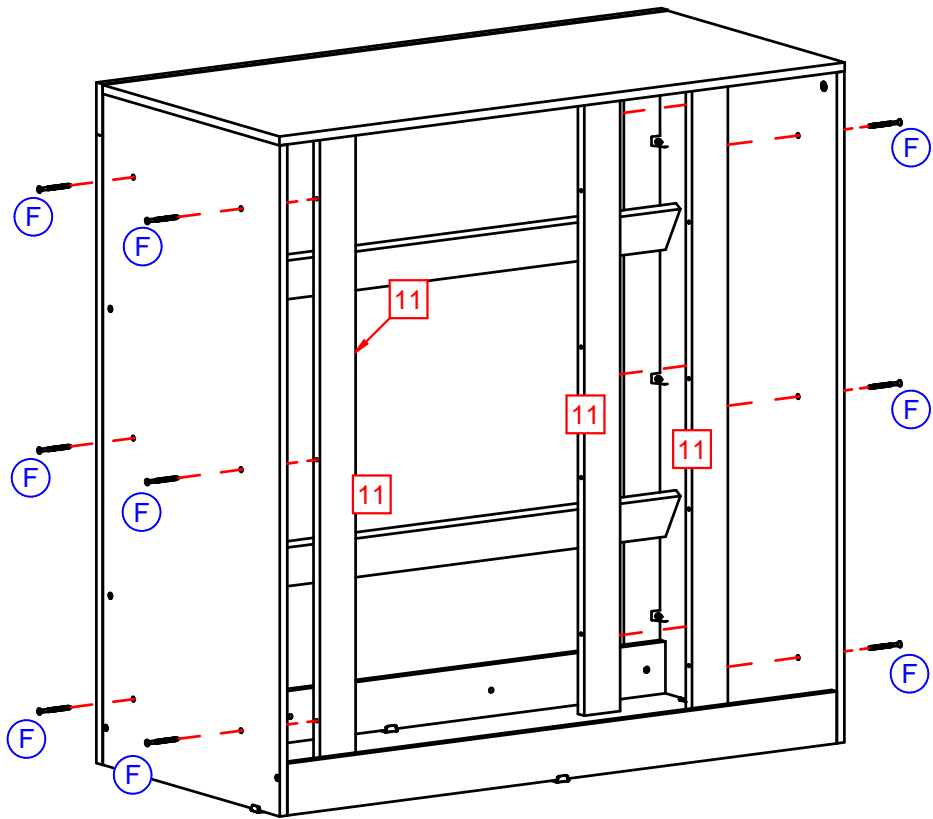

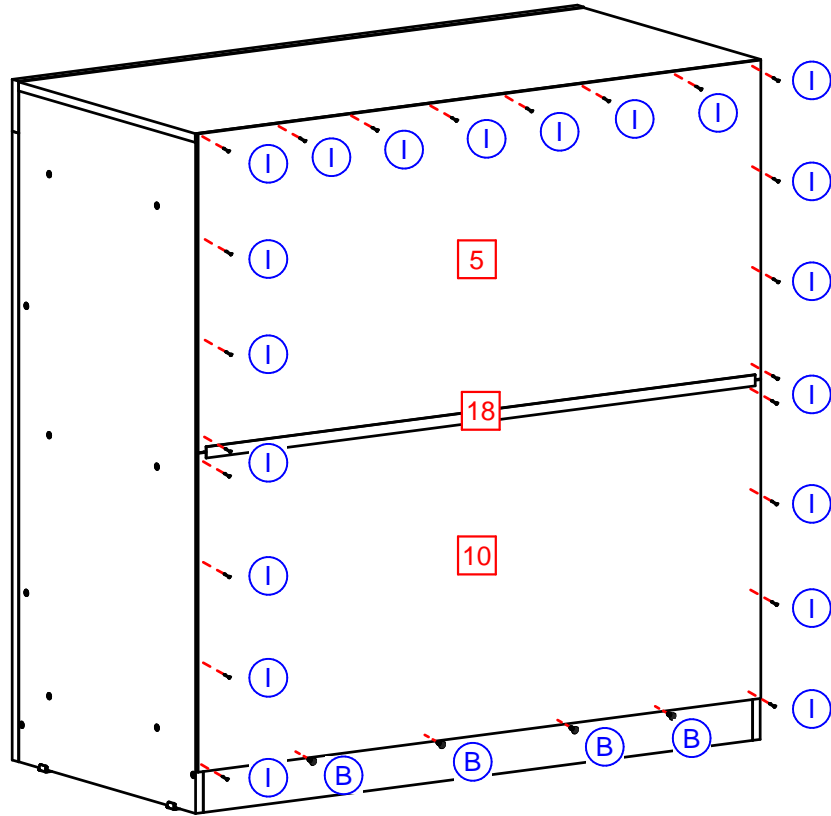

9 X 4

9 - A

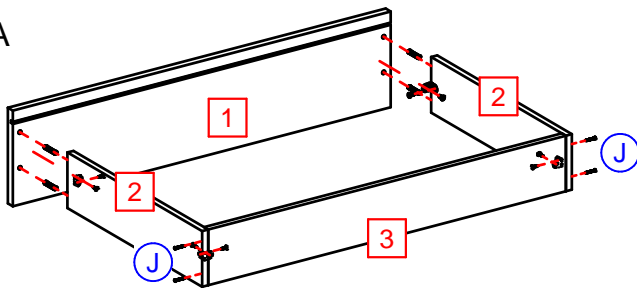

9 - B

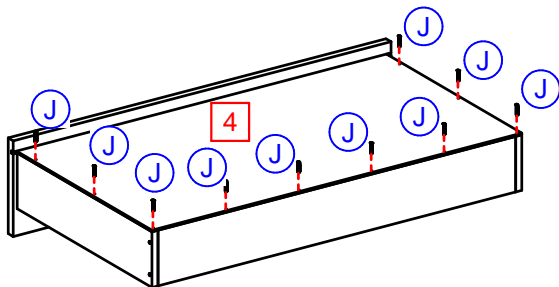

9 - C

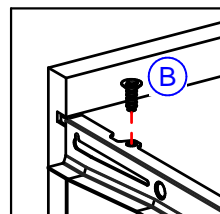
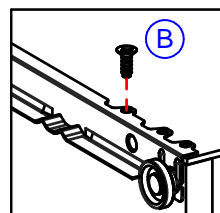
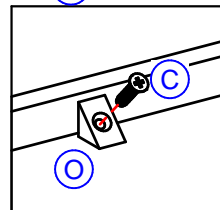
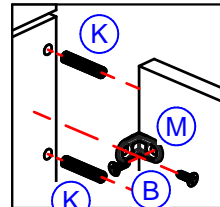
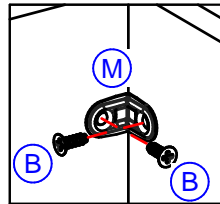
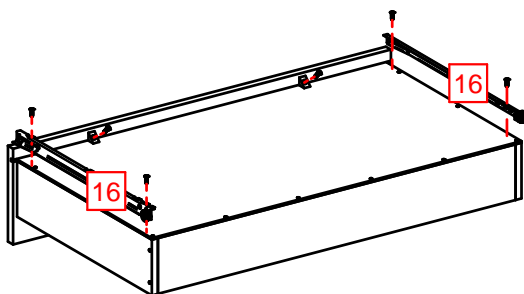

Colocación del espejo / Mirror fixation / Colocação do Espelho

** Espejos Opcionales
** Mirrors Optional
** Espelhos Opcionais

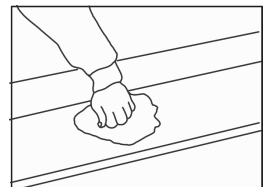
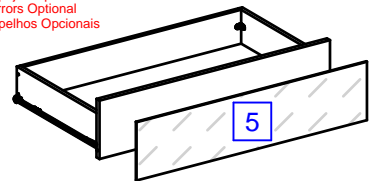

Limpiar la frente del cajón con paño seco.
Clean the drawer front with one dry cotton.
Limpar a frente com um pano seco.

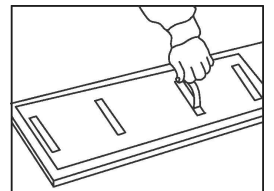

Sacar con cuidado la protección de la cinta dupla face.
Take off carefully the protection of double band of the face.
Tirar com cuidado a proteção da fita dupla face.

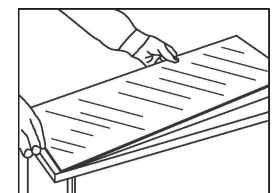

Poner el espejo, con cuidado.
Fix the mirror, carefully.
Colocar o espelho, cuidadosamente.

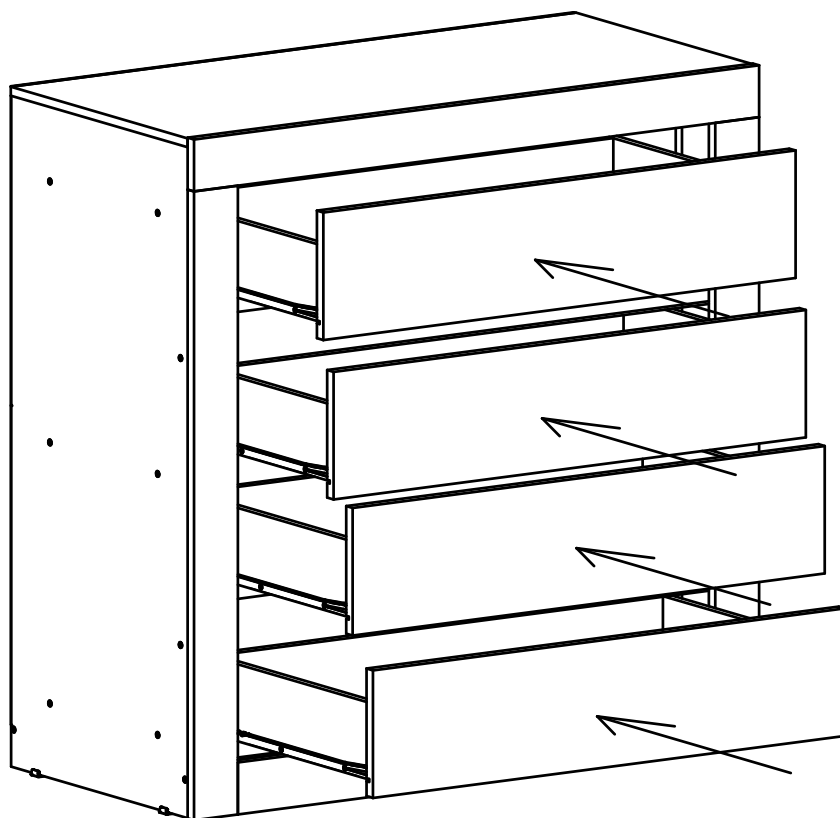

- 11 Si es necesario, ajuste la altura de los cajones
 If necessary, adjust the height of the drawers
 Caso necessário, ajuste a altura das gavetas

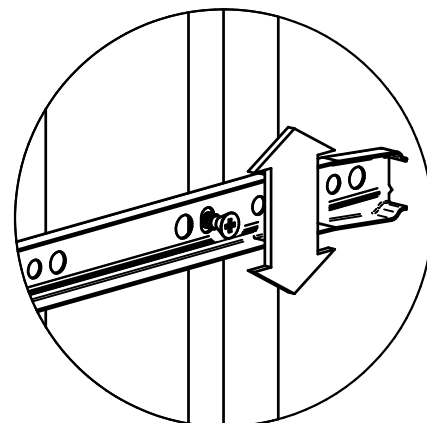
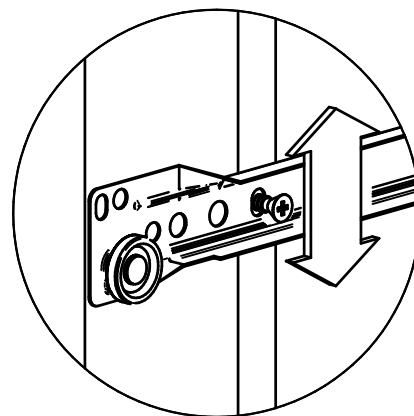
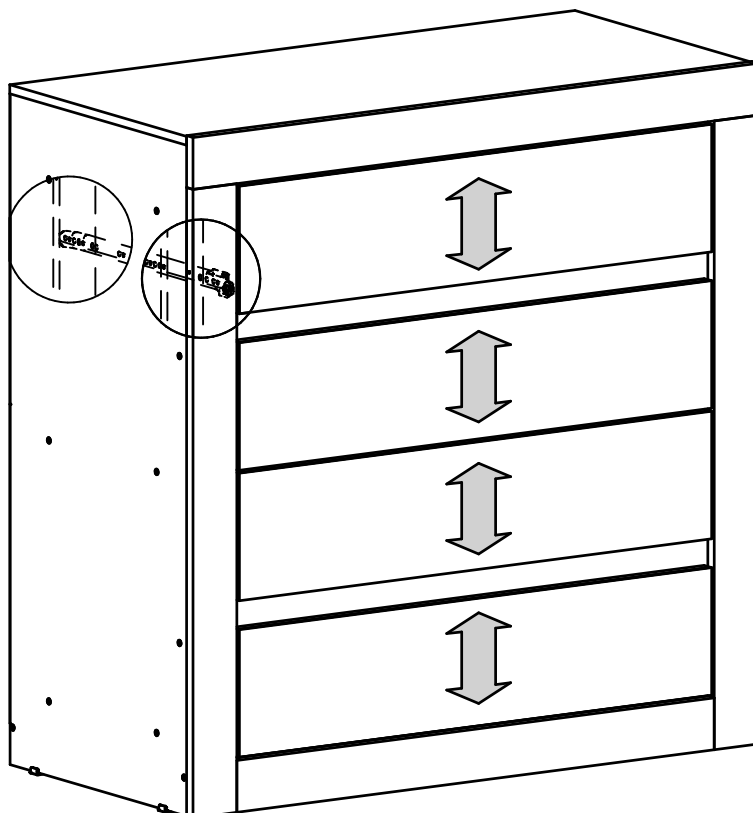

Dispositivo de seguridad / Safety device / Dispositivo de Segurança

